



**Moss Motors, Ltd.**  
440 Rutherford Street  
Goleta, CA 93117

PRESORTED  
STANDARD  
U.S. POSTAGE  
**PAID**  
MOSS MOTORS,  
LTD.

MOSS  
FALL/WINTER 2018



SPM-100

# SPRITE-MIDGET

## AUSTIN HEALEY SPRITE & MG MIDGET

**Save the date!**



*The Party Planning  
has Begun!*



The 2019 Moss Motorfest  
will be on **June 8, 2019.**

*Don't miss one of the biggest events of the year!*

AUSTIN-HEALEY SPRITE & MG MIDGET

SPM-100



***Make it Your Own!***

With Our Deep Selection of Parts & Accessories

**SINCE 1948**

800-667-7872 | MossMotors.com



# MOSS MOTORS, LTD.

## As original as you'd like it to be.

"Is that photo on the cover a picture of George Washington's interior?" It's not an entirely unreasonable question. The handle has been replaced many times, but the blade only once or twice.

When first shown the photos for our latest round of catalog covers, my knee-jerk reaction was to say no, because our customers wouldn't like a set of aspirational photos showing highly visible, "not original" parts. But I had to ask myself, what is incorrect, and by who's standard?

I'm the guy who says I've never tried to make a car original because someone else would always do a better job. And, if held to the same standard above, my whole collection would fail.

The thing is, it's not someone else's car, it's yours, and you should do with it as you please.

We cannot count the number of spectacularly flawless and accurate restorations we have seen. There are seemingly no limits to the quality of workmanship one may find at a car show. Sometimes, however, this fact can be daunting to those of us less able, or willing, to go the originality route.

With that in mind, this round of covers celebrates individual tastes. Go ahead and slap that SpongeBob sticker over the speedo. Old British cars aren't that fast anyway.

Happy Motoring,  
*Robert Goldman*

Robert Goldman  
Chairman, Moss Motors, Ltd.

## Visit Our Showrooms

### Eastern Showroom

25651 Simpson Rd.  
Petersburg, VA 23803  
Ph: 800-431-2496  
Hrs: Mon – Fri 9:00am – 4:30pm  
Sat – 9:00am – 3:00pm  
• March 1 - September 30

### Western Showroom

440 Rutherford St.  
Goleta, CA 93117  
Ph: 800-667-7872  
Hrs: Mon – Fri 8:30am – 4:30pm  
Sat – 9:00am – 3:00pm

Place a single order of \$1,500 or more and you will automatically receive 10% off regular priced parts for 12 months! You will also be paired with a dedicated Sales Person who will give you personalized service.

Extend your time on the Customer Loyalty Program - While a member of the Loyalty Program, order a total of \$1,000 or more within 12 months and we will extend your 10% discount for an additional year! Only one extension per year is allowed.

For more information, visit [MossMotors.com/Loyalty](http://MossMotors.com/Loyalty)



## Give The Perfect "Part"



You can provide exactly what your favorite British car enthusiast needs when you give a Gift Certificate. Gift Certificates are available in one dollar increments, and shipped USPS 1st Class or UPS Next Day or 2nd Day if you need faster delivery. Order by phone 800-667-7872 or online [MossMotors.com](http://MossMotors.com).



## Your Favorite Brands



Working on automobiles is inherently dangerous. Moss Motors, Ltd. is not liable for injury or damage due to incorrect installation or use of their products. All products are sold with the understanding that the safe and proper installation and use of the products is the customer's responsibility. Follow factory workshop manual procedures and instructions, but use current shop safety standards and common sense. Some tasks will require professional advice or services which Moss Motors cannot provide.

# See Your Car on the Cover

Great vehicles wanted! Contact [creative@mossmotors.com](mailto:creative@mossmotors.com) if you're interested in participating in a cover shoot.

# Sprite-Midget

## Featured Products

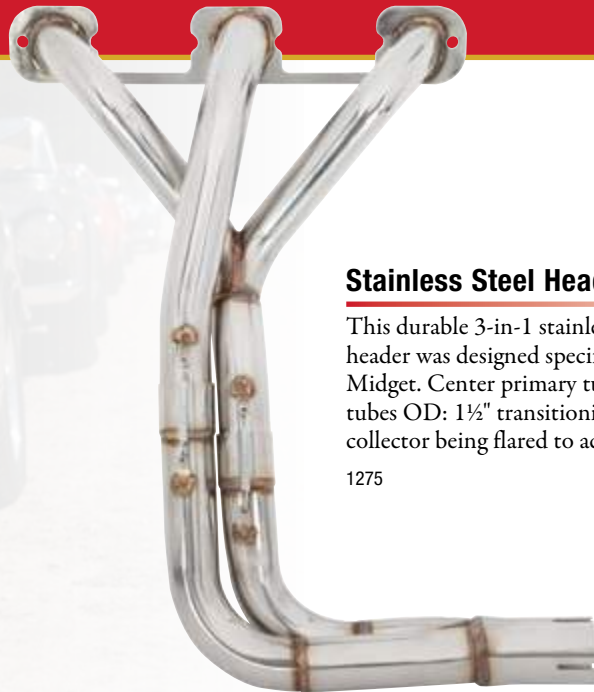

### Stainless Steel Header

This durable 3-in-1 stainless steel performance header was designed specifically for the 1275 Midget. Center primary tube OD: 1 1/2" Outside tubes OD: 1 1/2" transitioning to 1 3/8" with the collector being flared to accept 1 3/8" tubing.

1275

452-017 \$229.99

## Join Us Online



Check out Moss-TV for the latest Tech How-To's  
[MossMotors.com/MossTV](http://MossMotors.com/MossTV)



Regular british sports car history and Moss Updates  
[Facebook.com/MossMotors](https://Facebook.com/MossMotors)



Get inspiration for your next restoration project or build  
[Pinterest.com/Moss\\_Motors](https://Pinterest.com/Moss_Motors)



Photos of British sports cars at your fingertips  
[Instagram.com/Moss\\_Motors](https://Instagram.com/Moss_Motors)



Regular industry news, sales announcements, and more  
[Twitter.com/Moss\\_Motors](https://Twitter.com/Moss_Motors)

Follow all of our social media updates in one place!

[MossMotors.com/Social](https://MossMotors.com/Social)

## Moss Motoring

Moss Motoring is our magazine and also a website dedicated to British car enthusiasts. Visit [MossMotoring.com](http://MossMotoring.com) for volumes of information and stories, and to sign up to receive the magazine.



Place your order by 3 p.m. your local time and we will ship it the same day. See website for latest up to date information and details.



Free Shipping Over \$700. Orders over \$700 that go by UPS that are shipping to an address in the 48 States go free.

## Contents

Featured Products . . .	A4-A6
Accessories . . . . .	A7-A54
Restoration . . . . .	1-89
Order & Ship Info . . . .	A55
Order Form . . . . .	A56
Terms and Conditions & Privacy Policy . . . . .	90
Index . . . . .	91

## 2-Year WARRANTY

We stand behind the products we sell by offering the Longest Warranty in the business. Every Classic British Part is backed by our 2-Year warranty to be free from defects in material and workmanship.

See website for full details.



### PHONE ORDERS

US 800-667-7872 INTL 805-681-3400

### FAX ORDERS

805-692-2525

### ONLINE ORDERS

[MossMotors.com](http://MossMotors.com)

### CUSTOMER SERVICE

800-689-9313



# FEATURED PRODUCTS

A4



## MUS 4.3 Battery Test & Charge by CTEK

The MUS 4.3 Test and Charge combines an advanced microprocessor controlled battery charger with a battery and alternator test function to provide the ultimate in battery testing, charging and maintenance.

**Testing** - Three easy to use programs to test battery voltage, starting power and alternator performance to provide a complete picture of battery and vehicle charging system health.

**Charging** - MUS 4.3 Test and Charge provides excellent charging performance. The charger solves a broad range of battery problems. It features include a patented automatic desulphation program and a special reconditioning function that revives and restores deeply discharged and stratified batteries. The patented Float/Pulse maintenance makes the charger ideal for long-term maintenance.

### Features & Technical Info:

- Input 110-120VAC, 50-60Hz, 0.6A max
- Output 14.4V/14.7V/15.8V, 4.3A max
- Fully automatic 'connect and forget' 8 step 12V charging cycle
- 3 voltage test programs
- Battery types: All types of lead-acid batteries, 12V, WET, MF, Ca/Ca, AGM, GEL
- Insulation: IP65 (splash and dust proof)
- Patented float/pulse maintenance for batteries up to 160Ah
- 5 Year Limited Manufacturer Warranty

MUS 4.3 Battery Test & Charge 386-290 \$119.99

### Accessories

Silicone Bumper Cover 386-292 \$9.99  
 Mounting Bracket 386-293 9.99  
 Comfort Connect Cable 386-294 5.99  
 8.2 ft Extension Cable 386-295 9.99



386-293

## MXS 5.0 Battery Charger by CTEK

The MXS 5.0 is an advanced microprocessor controlled battery charger which gives unrivalled performance for batteries from 1.2-110Ah. It comes with automatic temperature compensation built in which ensures the best charging performance, even in the most extreme conditions. The MXS 5.0 also includes battery diagnosis to establish whether your battery can receive and retain a charge, patented automatic desulphation program, an AGM option which maximizes the performance life of most Stop/Start batteries and a special Recondition mode for reconditioning deeply discharged batteries. The MXS 5.0 uses CTEK's patented float/pulse system, which is the most efficient maintenance mode when a battery is connected for long periods.

### Features & Technical Info:

- Input 110-120VAC, 50-60Hz, 0.6A max
- Output 14.4V/14.7V/15.8V, 4.3A max
- Fully automatic 'connect and forget' 8 step 12V charging cycle
- Battery types: All types of lead-acid batteries, 12V, WET, MF, Ca/Ca, AGM, GEL
- Insulation: IP65 (splash and dust proof)
- Patented float/pulse maintenance for batteries up to 160Ah
- 5 Year Limited Manufacturer Warranty



CTEK

### New Feature offered with the MXS 5.0 Charger:

- Built in charge voltage temperature compensation according to ambient temperature

MXS 5.0 Battery Charge	386-296	\$92.99
<b>Accessories</b>		
Silicone Bumper Cover	386-292	\$9.99
Mounting Bracket	386-293	9.99
Comfort Connect Cable	386-294	5.99
8.2 ft Extension Cable	386-295	9.99



## Car Care by Jay Leno's Garage

Jay Leno's Garage started with a modest mission, develop detailing chemicals, tools and accessories that work and are easy to use. Their focus has been to produce detail supplies for the discerning automotive enthusiast rather than the discount-driven, big-box retailers. The JLG development process stems from real-world experience and necessity. So whether you're a professional detailer prepping for the next car show, or a weekend warrior detailing your daily driver out on the driveway, JLG products perform when it matters most.

Vehicle Wash - 16oz	220-850	\$9.99	Leather Cleaner - 16oz	220-858	\$9.99
Eco Wash - 16oz	220-851	9.99	Leather Conditioner - 16oz	220-859	17.99
Wash & Wax - 16oz	220-852	14.99	Odor Eliminator - 16oz	220-860	12.99
Wheel Cleaner - 16oz	220-853	14.99	Fabric Cleaner - 16oz	220-861	9.99
Quick Detailer - 16oz	220-854	9.99	Metal Polish - 16oz	220-863	19.99
All Purpose Cleaner - 16oz	220-855	9.99	Tire & Trim Care - 16oz	220-866	17.99
Spray Wax - 16oz	220-856	14.99	Vehicle Care Kit	220-869	59.99
Evaporate - 16oz	220-857	14.99	Interior & Quick Detail Kit	220-870	34.99
			9" Wheel Brush	220-871	9.99



800-667-7872

\*See ordering page for details

WWW.MOSSMOTORS.COM

# FEATURED PRODUCTS

A5



## GB40 Lithium Jump Starter by NOCO

The GB40 is a portable lithium-ion battery jump starter pack that delivers 1,000-amps (7,000 J3S) for jump starting a dead battery in seconds. It features a patented safety technology that provides spark-proof connections and reverse polarity protection making safe and easy for anyone to use. It's a powerful battery booster that doubles as a portable power source for recharging USB devices, like a smartphone, tablet and more.

### Features:

- A lithium battery jump starter rated at 1,000 Amps (7,000 Joules3S).
- Spark-proof connections and reverse polarity protection.
- Recharges USB devices, like smartphones, tablets, and more.
- 100 lumen LED flashlight with multiple modes, including SOS.
- Jump starts gas engines up to 6 liters, and diesel up to 3 liters.
- Provides up to 20 jump starts on a single charge.

GB40 Lithium Jump Starter 386-420 \$124.99



## Rover Mobile Task Light by Striker

The Rover is compact, lightweight (395grams / 0.87lbs), and of course is extremely durable. It features a aluminum head that acts as a fully functional heat sink. Unlike halogen shop lights, the Rover is always cool to the touch. The Rover is surrounded by a tempered steel exoskeleton, which has been drop tested extensively. The steel exoskeleton also acts as a stable base, or frame to hang the light. There is a universal tripod mount on the bottom of the Rover so users can elevate the light if necessary. It is powered by dual lithium-ion rechargeable batteries that boast 4000mAh ensuring you will have plenty of power, and long run times. Recharge by simply inserting the supplied USB cable into the plug on the back. If you need longer run times, the Rover can be used while plugged in. Once aimed, cycle through the 4 modes (High, Low, Strobe and SOS ) until you find the one that is right for your needs at the time.

### Features:

- 1200 lumens
- Dual focus lens
- Dual Lithium-ion battery technology
- Steel ExoSkeleton
- Universal camera tripod mount
- 4 light modes (high, low, SOS, strobe)

Rover Mobile Task Light 386-475 \$49.99



## H4 Style Headlamp LED Conversion Kit

Developed for H4 (Semi-Sealed) style headlamps a Stella Lux LED conversion represents a technological breakthrough for classic car owners. With modern vehicle lighting levels of 3000 Lumens per bulb, three times brighter than a standard H4 halogen bulb. These emit a bright white 6000K color and deliver vastly improved road presence and visibility for a safe confident driving experience whatever the conditions. The kit comes with a pair of premium quality 25W LUMILEDS LUXEON Z ES LED H4 light units with a 10,000+ hour lifespan and low load plug-and-play dual polarity drivers. Instructions included for a straightforward installation.

7" H4 Lucas Style - LED 171-250 \$169.99



Lucas

## Universal Fuel Pump Kit by Lucas

The Lucas universal fuel pump kit is an extremely quiet and reliable steel cased sealed unit with zinc plating. It includes attached filter, mounting bracket, push-on fuel pipe unions, two 3.4" lengths of fuel line and hose clips. This dual polarity 12v electric fuel pump is a direct replacement for AUA66 & AUA25 (Positive and Negative Earth). Suitable for all single, twin and triple carburettor installations and does not require an additional fuel pressure regulator.

### Technical specs:

- E85/ethanol compatible
- 6.77" Long
- 2.13" Dia
- 5 amps Current Draw
- Inlet and outlets threaded 1/8" NPT

Fuel Pump 377-186 \$99.99



## Oil Cooler Duct by Revotec

Supplied with laser cut aluminium mounting brackets and all fittings. Formed from HDPE to ensure reliability. Stepped inlet to accommodate two sizes of ducting. Supplied with Pull Through Kit for mounting.

Oil Cooler Duct - 13 Row	235-926	\$89.99
Oil Cooler Duct - 16 Row	235-996	89.99
Oil Cooler Duct - 19 Row	235-846	89.99
Hose Mount - 63mm	235-999	18.99
Neoprene Hose - 3ft	363-440	26.99
Neoprene Hose - 6ft	363-441	49.99

# FEATURED PRODUCTS

A6

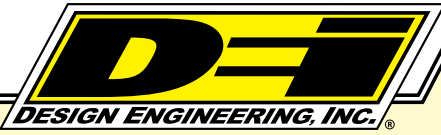

231-921 231-922

## Exhaust Wrap by DEI

Wrapping headers and down pipes is an important first step in reducing unwanted and power-robbing under hood heat. Less under hood heat results in a cooler air charge for improved performance and keeping exhaust gases hotter within the exhaust system helps in decreasing exhaust density and increases exhaust flow.

Tan - 1" x 50'	231-920	\$35.99
Tan - 2" x 50'	231-921	57.99
Black - 1" x 50'	231-922	39.99
Black - 2" x 50'	231-923	62.99



## Cool Tape by DEI

Cool Tape is a flexible and super strong self-adhesive thermal insulating tape capable of protecting up to 2000°F of radiant heat. Made of one mil aluminized material bonded to a woven glass fiber heat resistant matting, Cool Tape is an ultra light weight heat reflective solution for wrapping wires, cables, hoses, fuel lines, covering seams and many other uses.

15ft	231-940	\$19.99
30ft	231-941	36.99



231-930  
231-931  
231-932

## Exhaust Wrap and Tie Kit by DEI

DEI Pipe Wrap is used in many types of applications for reducing unwanted and harmful heat under the hood and from entering the driver compartment while improving horsepower. Kit includes one roll of 2in x 25ft exhaust wrap and four 8" stainless steel locking ties to secure wrap.

Black	231-930	\$32.99
Tan	231-931	31.99
Titanium	231-932	36.99

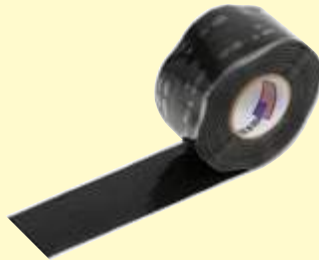

## Quick Fix Tape by DEI

High performance Quick Fix Tape bonds to itself and is self-curing, forming a waterproof permanent seal. It's ideal for emergency hose repair, non-slip grip surface for tools, electrical splices and connections, serves as a temporary leak sealer, and does not leave a sticky residue after removal. Just a few of its many uses. Extruded from a special high performance grade silicone compound and engineered at 700psi tensile strength, Quick Fix Tape has insulating capabilities up to 8,000 volts and stretches to three times its length for a simple stretch-and-wrap application. The triangular profile of the tape (the center is thicker than the edges) provides a smooth edge when over lapping tape. Sold in 1" wide x 12' long rolls.

Quick Fix Tape	231-945	\$13.49
----------------	---------	---------



460-059



460-058

## Billet Tappet Cover Kit

These billet aluminum tappet covers have been meticulously machined to fit your car. They are available either plain or with a machined Union Jack. The kit includes tappet cover, gasket, bushing, cup washer and bolt. Sold individually.

Plain - each	460-058	\$39.99
Union Jack - each	460-059	79.99



## Hi-Temp Silicone Coating Spray by DEI

The High Temperature (HT) Silicone Coating provides lasting protection for any hot surface up to 1500 degrees. DEI recommend the use of this coating with their exhaust wrap because it seals the material and provides lasting protection from oil, dirt and road grime. Don't limit the use to exhaust header wrap, because this products works well on headers, blocks, starters and even on your grill at home. HT Silicone Coating is VOC (Volatile Organic Compounds) compliant in all 50 states. Recommended for use with DEI non-Titanium exhaust wraps, HT Silicone Coating penetrates, seals and protects to help extend the lifespan of exhaust wrap.

Black	231-935	\$11.99
Aluminum	231-936	11.99
White	231-937	11.99



800-667-7872

\*See ordering page for details

WWW.MOSSMOTORS.COM

# RetroSound®



230-331

230-332



230-386

## Vintage Style Radio by RetroSound

RetroSound radios deliver superb sound and the latest audio features without compromising the original style of your dash. We carry a variety of their head units so you can choose the perfect solution for your audio needs. Add their Hide-Away Antenna #230-555 to install an amplified antenna behind your dash or in your trunk. Negative ground only. Knobs sold separately.

Laguna (Chrome)	230-355	\$219.99
Hermosa Radio (Chrome)	230-390	289.99
Hermosa Radio (Black)	230-395	289.99
Long Beach (Chrome)	230-381	399.99
Long Beach (Black)	230-386	399.99
SiriusXM Direct Connect Tuner	230-379 <sup>1</sup>	69.99
Chrome Surround w/Chrome Knobs	230-326	42.99
Black Surround w/Chrome Knobs	230-329	42.99
Black Surround w/Black Knobs	230-327	42.99
Knob Set - Chrome	230-331	20.99
Knob Set - Black	230-332	20.99
USB/AUX Cable with Mount - Black	230-356 <sup>2</sup>	32.99
USB/AUX Cable with Mount - Chrome	230-357 <sup>2</sup>	32.99
Hide-Away Amplified Antenna	230-555	29.99

<sup>1</sup>Long Beach radios only.

<sup>2</sup>Long Beach and Hermosa radios only.



230-322



230-390

FEATURES	LAGUNA	HERMOSA	LONG BEACH
Made for iPod charge & play operation	NO	NO	YES
Bluetooth w/handsfree mic input	NO	YES	YES
AM/FM tuner w/RDS & 30 Presets	YES	YES	YES
Tuner Country Compatibility	US/EU	US/EU	US/EU/JAPAN/AUS/LATIN AMERICA/RUS
Remote Control	NO	NO	TBA (VIA MOBILE APP, BLUETOOTH)
LCD Illumination Color	WHITE	WHITE/GREEN	32,000 BACKLIGHT COLOR CHOICES
High-Resolution LCD display	YES	YES	YES
Built-in amplifier	YES, 50 X 4 RMS	YES, 25 X 4 RMS	YES, 25 X 4 RMS
Auxiliary Inputs	2 (1 FRONT, 1 REAR)	2, REAR	2, REAR
USB Input for MP3/WMA Playback	NO	YES	YES (VIA USB/SD BOX)
External USB/SD card reader	NO	NO	YES
Pre-amp RCA outputs	YES, 2 PAIR	YES, 2 PAIR	YES, 2 PAIR
Subwoofer Output	NO	NO	YES W/OVER & LEVEL CONTROL
DSP EQ	YES	YES	YES
Clock w/clock priority	YES	YES	YES
A2DP wireless streaming	NO	NO	YES
New rear knob/shaft functions	NO, FRONT ONLY	YES, FRONT & REAR	YES, FRONT & REAR
Available w/chrome radio face	YES	YES	YES
Available w/black radio face	NO	YES	YES
Compatible w/all RetroSound knob/bezel/plate kits	YES	YES	YES
Warranty	1 Year	1 Year	2 Years



## RetroMod Speakers by RetroSound

When British sports cars encounter modern technology, sometimes there is a standoff. Technology doesn't always turn microscopic. Take car speakers for example: just try stuffing new ones into your little car. RetroMod speakers are different. They're more than able to meet today's high performance amplifiers and yet they are ultra thin. 1.77" mounting profiles fit virtually any installation application. The secret is neodymium magnets that are 5x more powerful than standard speaker magnets. Also, if you want to keep accessories to a minimum, Dual Voice Coil design (DVC) lets you connect 2-channels from your radio to one single speaker, providing full stereo sound.

Speaker, DVC N-Series, 6.5" diameter, 3-way - each	230-505	\$79.99
Speakers, SVC N-Series, 4.5" diameter, 2-way - pair	230-535	94.99



230-505



230-535



## Amplified Hide-Away Antenna by RetroSound

Don't compromise the beauty of your classic when adding an antenna for an upgraded stereo. The Hide-Away amplified antenna from RetroSound comes with a 105-inch antenna cable and power lead so it can be mounted in hidden places such as behind your dash or in your trunk. Installs to standard Motorola antenna plug and radio power lead. Small box is 4" x 1" x 1".

Amplified Hide-Away Antenna	230-555	\$29.99
-----------------------------	---------	---------

# INTERIOR

## A8 UPHOLSTERY



### Seat Kits

No matter what else you do to your car, one thing everyone notices is the condition of the seats. Put your seats in tip top condition with a "just as it came from the factory" vinyl kit, or upgrade your car's interior with one of our luxurious leather kits. All of the Sprite and Midget seat kits we sell are made of the very best materials and patterned exactly like the originals. All front seat kits include covers for both front seats. Don't forget pads and cushions - we stock a complete selection to properly fill out your new covers, and make your "new" seats as comfortable as can be.

*Note: Headrest covers available separately.*



A



B

### Seat Towels

Don't toss any old towel over your seat to protect your upholstery! This Seat Towel is designed especially for your seats, and features the Union Jack flag in full color or black and white. Made from cotton terrycloth, this cover is easily removed and installed, and machine washable.

#### Union Jack

(A) Red/White/Blue 216-590 \$49.99

#### Black

(B) Checkered & Union Jack 216-592 \$49.99



A  
640-779

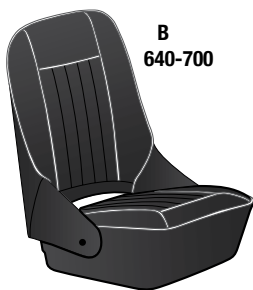

B  
640-700

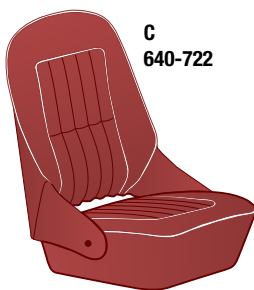

C  
640-722

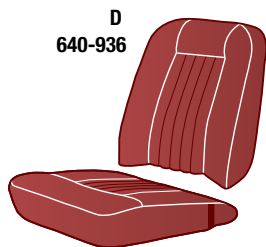

D  
640-936

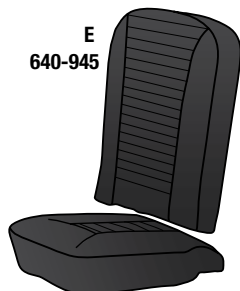



E  
640-945



F  
640-980

### Seat Kits

	Black w/White Piping	Black	Red w/White Piping	Navy w/Lt. Blue Piping	Navy w/Navy Piping	Navy	Blue w/White Piping	Blue w/Lt. Blue Piping	Autumn Leaf	Price
<b>(A) Bugeye Sprite, 948 Sprite MkII 1958-62</b>										
Vinyl Seat Kit	640-777	640-771	640-778	640-776	640-772	-	640-773	640-779	-	\$429.99
Leather Seat Kit	640-781 <sup>1</sup>	640-783	640-782	640-784	640-786	-	-	-	-	699.99
<b>(B) 948 Midget MkI 1961-62</b>										
Vinyl Seat Kit	640-700	-	640-702	640-703	640-704	-	640-705	640-706	-	\$429.99
Leather Seat Kit	640-710	-	640-712	640-713	640-714	-	-	-	-	699.99
<b>(C) 1098 Sprite MkII &amp; MkIII, Midget MkI &amp; MkII 1963-64</b>										
Vinyl Seat Kit	640-720	640-721	640-722	640-723	640-724	-	640-725	640-726	-	\$429.99
Leather Seat Kit	640-740	640-741	640-742	640-743	640-744	-	-	-	-	699.99
<b>(D) 1098 Sprite MkIII &amp; 1275 MkIV, Midget MkII &amp; MkIII 1965-68</b>										
Vinyl Seat Kit	640-910	640-931	640-936	640-932	640-933	-	640-934	640-937	-	\$379.99
Leather Seat Kit	640-965	640-964	640-966	640-963	640-962	-	-	-	-	599.99
<b>(E) 1275 Sprite MkIV, 1275 Midget MkIII 1969</b>										
Vinyl Seat Kit, fixed back	-	640-945 <sup>2</sup>	-	-	-	-	-	-	-	\$474.99
Vinyl Seat Kit, reclining back	-	640-950 <sup>2</sup>	-	-	-	-	-	-	-	499.99
Leather Seat Kit, fixed back	-	640-800 <sup>2</sup>	-	-	-	-	-	-	-	1,049.00 
<b>(F) 1275 Sprite MkIV, 1275 Midget MkIII &amp; Midget 1500 1970-on</b>										
Vinyl Seat Kit	-	640-960 <sup>2</sup>	-	-	-	640-930 <sup>2</sup>	-	-	640-980 <sup>2</sup>	\$489.99
Leather Seat Kit, fixed back	-	640-805	-	-	-	-	-	-	640-810 <sup>2</sup>	1,149.00 

<sup>1</sup>Special order, allow 6-10 weeks for delivery.  
<sup>2</sup>Headrest covers not included.

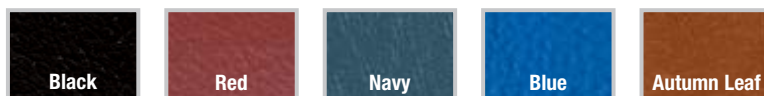

### Seat Slides, Foams, Door Seals & Hardware

You'll find a complete listing of all the interior components you need to restore your Sprite or Midget in the Replacement Parts section of this catalog.



800-667-7872

\*See ordering page for details

WWW.MOSSMOTORS.COM



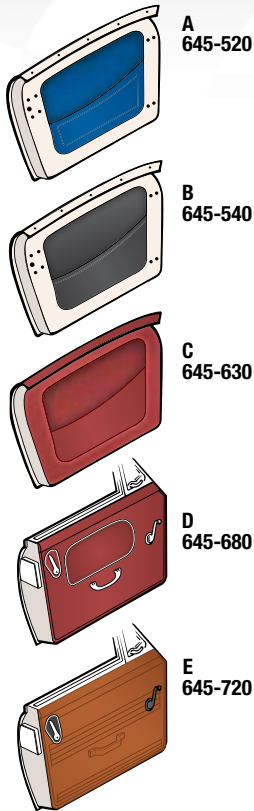

## Interior Panel Kits

	Black	Red	Navy	Blue	Price
(A) Bugeye Sprite; 1958-60	645-500	645-510	645-530	645-520	\$329.99
(B) 948 Midget Mkl, 948 Sprite MklI; 1961-62	645-540 <sup>1</sup>	645-550 <sup>1</sup>	645-565 <sup>1</sup>	645-560 <sup>1</sup>	379.99
(C) 1098 Sprite HAN7, Midget GAN2; 1963	645-620	645-630	-	-	419.99
(D) 1098 Sprite HAN8, Midget GAN3; 1964-66	645-570 <sup>2</sup>	645-580 <sup>2</sup>	-	645-585 <sup>2</sup>	594.99

	Black w/Black Piping	Black w/White Piping	Red w/White Piping	Price
(D) 1275 Sprite HAN9, 1275 Midget GAN4; 1967-69	645-660	645-670	645-680 <sup>1</sup>	\$649.99

	Black	Navy	Autumn Leaf	Price
(E) 1275 Midget GAN5, 1500 Midget GAN6; 1970-80	645-700	645-710 <sup>1</sup>	645-720	\$429.99

<sup>1</sup>Special order, allow 6-10 weeks for delivery.

<sup>2</sup>With White Piping



## Midget Headrest Assemblies & Headrest Covers

These faithfully crafted headrest assemblies and headrest covers offer a perfect solution to the often missing or weather-ruined headrest issue. Offered in both "Eared-type" or "Teardrop-type", you can select from a variety of factory colors. Sold individually.

### Headrest Assembly

	Black	Navy	Ochre	Autumn Leaf	Champagne	Price
1970-76 "Eared-type" Perforated Headrests	649-100	-	-	649-130	-	\$109.99
1970-76 "Eared-type" Non-Perforated Headrests	649-140	649-150	-	649-170	-	109.99
1977-80 "Teardrop-type" Non-perforated Headrests	641-605	641-615	-	641-635	-	104.99

### Headrest Covers

	Black	Navy	Ochre	Autumn Leaf	Champagne	Price
1970-76 "Eared-type" Non-Perforated Headrests	640-200	640-210	640-220	640-225	-	\$51.99
1977-80 "Teardrop-type" Non-perforated Headrests	640-335	-	-	640-345	-	58.99

<sup>1</sup>Special order, allow 6-10 weeks for delivery.

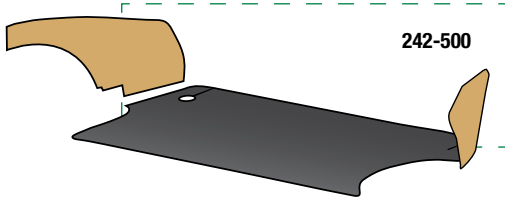

## Bugeye Rear Deck & Trunk Liner Set

The Bugeye was originally supplied with a rubber mat type of material on the wheel arches, rear deck and vertical panel leading from the floor to the rear deck. In the trunk area was a hardura mat and with grey side panels.

Our trunk liner set includes the trunk floor in black Hardura and side panels made from fiber board that need to be painted in the original grey color. (Use this kit when you order the 1961-63 carpet set which will cover the rear deck area in carpet).

Our deck and trunk liner set includes the trunk liner set and all the pieces to cover the rear deck, wheel arches and vertical panel between the floor and rear deck in black Hardura. (Use this kit when ordering the Bugeye specific carpet set that only covers the floors in carpet).

Trunk Liner Set, Bugeye	242-500	\$109.99
Deck & Trunk Liner Set, Bugeye	242-501	199.99

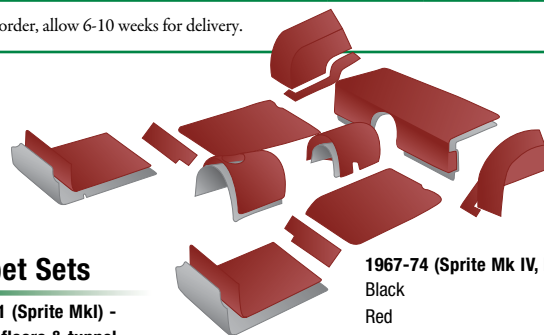

## Carpet Sets

### 1958-61 (Sprite Mkl) - Covers floors & tunnel

Black	242-531	\$279.99
Red	242-532	279.99
Navy	242-533	279.99
Honey Tan	242-578	279.99

### 1961-63 (Sprite Mk II, Midget I)

Black	242-541 <sup>1</sup>	\$299.99
Red	242-542 <sup>1</sup>	299.99
Navy	242-543 <sup>1</sup>	299.99

### 1964-66 (Sprite Mk III, Midget Mk II)

Black	242-551	\$289.99
Red	242-552	289.99

### 1967-74 (Sprite Mk IV, Midget Mk III)

Black	242-560	\$319.99
Red	242-570	319.99
Autumn Leaf	242-580	319.99
Navy	242-555	319.99

### 1975-80 (Midget 1500)

Black	242-571	\$319.99
Red	242-572	319.99
Autumn Leaf	242-573	319.99

<sup>1</sup>Can be used on bugeye if you want rear deck and riser covered in carpet.

For Free Samples of our carpet material, order sample card **#878-915**

Autumn Leaf

Blue

Navy

Red

Black

Black

Red

Navy

Autumn Leaf

# INTERIOR

## A10 ACCESSORIES



Before



After

### LED Dash Bulb

LED lighting in cars is becoming increasingly popular, and your classic can benefit too. Bright white LED dash bulbs illuminate your gauges very well, and are a replacement for the standard incandescent bulb #171-000. A bit more expensive at the outset, but LEDs burn cooler and last much longer than standard incandescent bulbs. LED light is not dimmable. LEDs should not be used as turn signal indicators or for the red generator/alternator light on the dash. Sold individually.

Negative Ground	170-972	\$4.99
Negative Ground - Short Profile	170-971	9.99
Positive Ground	170-975	9.99
Positive Ground - Short Profile	170-973	9.99
Wedge Type - Positive or Negative	170-976	3.99
Wedge Type - Positive or Negative - Short Profile	170-977	3.99

### Oil Pressure/Water Temperature Gauge

This genuine Smith's combination gauge is a direct replacement for the obsolete originals. Gauge has black face with white lettering and needles, and a 82" capillary tube. Fits Sprite through MkIV, Midget MkI through 1500. Lettering and the scales may differ from the instrument in your car.



Sprite to MkIV, Midget MkI-1500 361-761 \$209.99



### Ignition Key Blanks

Original keys are extremely rare. Keys are blank and must be cut locally. Order by the series number of your original locks.

	Crested	Non-Crested	BL
MRN Series	\$9.89	\$5.49	\$15.89
FA Series	163-310	163-510	-
FS Series	163-320	163-535	-
FP Series	163-330	163-545	-
AA Series	163-340	163-550	-
MG Series	163-370	-	163-375
RV Series	-	-	163-365
WS Series	163-380	-	163-355
BL Series	-	-	163-345
			163-335



### Velour Door Seals

Originally fitted to early cars, this velour material door seal is a more luxurious option for later cars. Featuring a steel wire core that clamps securely and a correctly sized bulb to ease installation and improve sealing. Sold by the yard, 4-yards required.

Black Furlflex Seal 249-609 \$16.99



### Festoon Style LED Interior Bulb

Our LED festoon style interior bulbs illuminate your interior with bright white light. LEDs are more efficient than standard incandescent bulbs, burning cooler and lasting longer. This bulb replaces the standard festoon style incandescent bulb (#170-010). It is directional, so it must be properly aligned in sockets. Positive and negative ground. Sold individually.

Festoon Style LED Interior Bulb 170-996 \$10.99



### OEM Style Cigarette Lighter

To replace a defective original, or add an electrical outlet to earlier cars. This kit includes a complete illuminated lighter assembly as fitted to many British cars.

Cigarette Lighter Kit 142-270 \$8.69  
Underdash Bracket 142-271 10.79



### 1968-80 Dash Pad Cover

Revitalize your old cracked dash top pad with this molded ABS cover. Comes complete with adhesive and instructions.

Dash Pad Cover 453-950 \$62.99



### Glare Shield

The glare shield attaches to any vehicle visor in just seconds. It offers protection for either driver or passenger and doesn't obstruct the view of the road ahead. Solid visors obscure vision - this shield allows the user to view the whole picture! The glare shield conveniently fits on all vehicle visors, folds up and away on top of your visor when not in use and can easily be removed for cleaning. Designed for safety, it is lightweight, smooth-edged and shatterproof.

Glare Shield 225-755 \$25.99



### Center Console & Armrest

Similar to vintage aftermarket consoles made by Amco some years ago. Black grained ABS thermoplastic base with leather covered armrest. A large storage compartment is located under the armrest pad and a cup holder is located in the forward portion.

Center Console & Armrest 453-805 \$139.99



### Ribbed Aluminum Trim Plates

#### Sprite Logo Threshold Plates

Our threshold plates are easy to install. Add a custom touch while protecting your door sills from scuffs and scratches. Set of two.

#### Ribbed Aluminum Frame Cover Plates

Four piece set to cover the exposed frame sections in your interior.

Logo Threshold Plates	240-660	\$66.99
For 1/4 Elliptic Springs	240-510	107.99
For 1/2 Elliptic Springs	240-550	99.99

### Stalk Caps

Caps for the ends of your wiper and turn signal stalks finish off your interior. Sold in pairs.



1968-80 Stainless Steel 141-775 \$10.99



800-667-7872

\*See ordering page for details

WWW.MOSSMOTORS.COM



## Steering Wheels by Tourist Trophy

**TOURIST TROPHY®**

Tourist Trophy offers a complete selection of wood and leather steering wheels for most British cars, and they are the best-looking wheels we have found. Your choice of finish, material, grain, width and feel. It's the perfect way to personalize your interior. Made to the highest standards using aluminum frames for lightweight strength. Because the wood is unique to every piece, final stain color and grain patterns may vary. Requires adapter hub sold separately.

### Solid Wood Rimmed Steering Wheels

14" 3-spoke Matte/Drilled	489-095	\$289.99
15" 3-spoke Matte/Drilled	489-090	289.99

### Laminated Wood Rimmed Steering Wheels

14" 3-spoke Matte/Drilled	489-070	\$289.99
15" 3-spoke Matte/Drilled	489-060	289.99
14" 3-spoke Matte/Slotted	489-085	289.99
15" 3-spoke Matte/Slotted	489-080	289.99

### Leather Rimmed Steering Wheels

14" 3-spoke Black/Drilled	489-040	\$229.99
14" 3-spoke Matte/Drilled	489-030	229.99
15" 3-spoke Matte/Drilled	489-020	229.99
15" 3-spoke Black/Slotted	489-050	229.99

### Accessories

Matte Ring Kit	489-077	\$7.99
----------------	---------	--------



489-090  
Shown mounted on  
wheel adapter hub:  
905-478



489-077

**MORE  
INFO  
ONLINE**



905-654

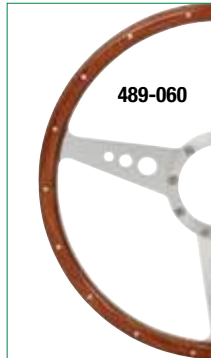

489-060



489-040

## Billet Horn Push by Tourist Trophy

Engineered specifically for our Tourist Trophy and Moto-Lita Adapter Hubs and machined from aircraft-quality aluminum, you will enjoy the precision feel and crisp appearance of this Billet Aluminum Horn Push Assembly. Comes complete with a 46mm MG or Austin-Healey emblem.

MG Logo	905-653	\$89.99
Austin-Healey Logo	905-654	89.99



454-366

905-648

## Complete Wheel Adapter Kits

Includes hub, horn push and emblem.

Midget MkI 1961-63	905-348	\$109.99
Midget MkII, III 1964-67	454-366	109.99
Midget MkIII 1968-69	905-468	179.99
Midget MkIII 1970-77	905-482	89.99
Midget 1500 1978-79	905-486	99.99
Sprite MkI, II 1958-63	905-346	109.99
Sprite MkIII, IV 1964-67	454-368	109.99
Sprite MkIV 1968-69	905-478	179.99

### Horn Push and Emblem Only

With 46 mm Healey Emblem	905-648	\$29.99
With 46 mm MG Emblem	905-646	29.99



## Leather Steering Wheel Cover by Wheelskins



These premium-grade black leather covers are custom tailored to fit your wheel. Simple installation results in a quality factory-fitted appearance. Made in the USA.

Dia: 16 1/2"-17"; Grip: 2 3/8"	222-310	\$69.99
Dia: 16 1/2"-17"; Grip: 2 1/2"	222-315	69.99
Dia: 15"-16"; Grip: 2 3/4"-3 1/8"	223-610	69.99
Dia: 16 1/2"-17 1/2"; Grip: 2 3/4"-3 1/8"	223-620	69.99



**NEW DISHED  
STYLE AVAILABLE**



499-520



499-580

Shown mounted on wheel  
adapter hub: 905-468

## Moto-Lita Steering Wheels

Moto-Lita steering wheels employ attractive bicolored wood laminations or black leather over aircraft aluminum frames. Requires additional adapter hub sold separately.

### Wood Rimmed Wheels

13" 3-spoke Polished/Drilled - Flat	499-530	\$399.99
13" 3-spoke Polished/Drilled - Dished	499-585	399.99
14" 3-spoke Polished/Drilled - Flat	499-560	399.99
14" 3-spoke Polished/Drilled - Dished	499-590	399.99
15" 3-spoke Polished/Drilled - Flat	499-540	399.99
15" 3-spoke Polished/Drilled - Dished	499-595	399.99
15" 3-spoke Polished/Teardrop - Flat	499-580	399.99
15" 4-spoke Polished/Solid - Flat	454-245	499.99

### Leather Rimmed Wheels

13" 3-spoke Polished/Drilled - Flat	905-145	\$399.99
13" 3-spoke Polished/Drilled - Dished	905-075	399.99
14" 3-spoke Polished/Drilled - Flat	499-520	399.99
14" 3-spoke Polished/Drilled - Dished	905-080	399.99
15" 3-spoke Polished/Drilled - Flat	499-500	399.99
15" 3-spoke Polished/Drilled - Dished	905-085	399.99

### Accessories

Polished Ring Kit	905-635	\$31.99
-------------------	---------	---------

## Shift Knobs

You're not going to throw any random knob on your shifter. Yours will be a natural fit for you and your sports car. Our gearshift knob is just the right size and feel, and is made of elegant walnut wood or trimmed in black leather and topped with a medallion displaying the logo.

### Wood Crested

Midget	234-010	\$27.99
Sprite	234-040	27.99

### Leather Crested

Midget	234-015	\$27.99
Sprite	234-045	27.99



cut-away  
view

# INTERIOR

## A12 FLOOR MATS

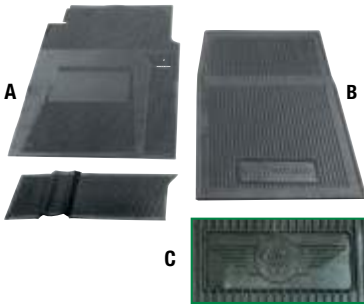

### Amco-Style Rubber Floor Mat Sets

Protect your carpets from dirt, wear and fading. If mats get dirty, hose them down and return them to the car. Sold in pairs. Black.

(A) Side Curtain Cars	241-870	\$37.99
(B) Midget MkII-1500	241-860	37.99
(C) Sprite MkII-IV	241-880	37.99



### Ultra Plush Embroidered Floor Mat Sets

Custom tailored for a perfect fit, these mats are made with an ultra-dense plush carpet and non-slip rubber backing. Features embroidered logos.

Sprite	240-471	\$149.99
Midget 1961-74	240-481	149.99

**NEW**



### Floor & Tunnel Shield by DEI

Designed to provide the best possible heat protection in areas where high temperatures are always present and problematic, Floor & Tunnel Shield II limits heat transfer on fire walls, transmission tunnels, floor boards, fuel cells and other areas where heat is an issue. It provides excellent light weight thermal protection, acts as a guard against track and road debris, and provides sound deadening as well.

Constructed with an embossed 10 mil aluminum face bonded to 3/8" composite glass-fiber core and backed with a high temp super strong pressure sensitive backing, it withstands up to 1750°F of direct continuous heat. The adhesive side holds past 450°F. Its improved multifaceted modern aluminum surface offers improved reflectivity and rigidity and allows for ease of installation. At only 3/16" thick, this product can be shaped and trimmed for a custom fit and is ideal for minimal clearance areas.

10"x10"	231-904	\$11.99
24"x21"	231-901	45.99
48"x21"	231-902	91.99
48"x42"	231-903	181.99

## Reduce Heat & Noise with Hushmat

### Custom Sound & Heat Insulation Kits by Hushmat

HushMat sound deadening & thermal insulation material leads the automotive industry in performance and ease of installation. Packaged specifically for your Sprite/Midget to provide 100% insulation coverage. No holes in the material - no puzzle pieces to put together - simply apply the HushMat Ultra material, as shown in the Installation Guides. Kits available for your Firewall, Doors, Floorpan, Trunk Floor or Complete Vehicle. Reduce road noise, exhaust noise and insulate your vehicle. Superior performance and adhesion is guaranteed.

Complete Vehicle Kit	409-250	\$469.99
Trunk Kit	409-270	229.99
Floorpan Kit	409-255	249.99
Door Kit	409-265	79.99
Firewall Kit	409-260	79.99

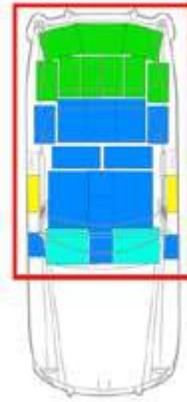

Complete Kit  
Trunk Kit  
Floor Pan Kit  
Door Kit  
Firewall Kit

### HushMat Ultra & Ultra II Insulation Kits

Hushmat is easy-to-install butyl damping pads reduce road noise and vibration, creating a solid and quieter environment. It will also allow you to stay warmer in the winter and cooler in the summer by reducing thermal transfer by over 40% when compared to other products. The HushMat Ultra II Hoodliner Kit is made from the same material, only slightly thicker for increased insulation. It trims easily with a just standard razor knife or household scissors making installation a snap. Adhesion is guaranteed with its self-adhesive peel and stick. Manufactured only in the United States of America.

<b>HushMat Ultra Door Kit</b>		
10 - 12" x 12" sheets	409-009	\$99.99
<b>HushMat Ultra II Hoodliner Kit</b>		
6 - 12" x 23" sheets	409-007	\$129.99
<b>HushMat Ultra Interior Kit</b>		
8 - 12" x 23" sheets	409-013	\$149.99

# HushMat



### Heatshield Material

This foil-covered insulation reduces unwanted heat, cold and sound inside the vehicle when installed under carpets, over the transmission tunnel and against the firewall. The closed-cell insulating material has a layer of foil on both sides, and will not absorb moisture like its jute or cotton counterparts. Lightweight and easily managed, it is sold in 4' x 6' sheets which can be cut to fit with scissors or a sharp knife.

Heat Shield Material	409-016	\$39.99	OS
Heat Shield Adhesive - 12 fl. oz.	409-037	19.99	

### Sound & Heat Control Insulation

Install on doors, floors and firewall. This insulation consists of an 80 mil. thick butyl rubber core covered by a 2.4 mil. aluminum coating. It deadens body panel vibrations and reduces heat transfer. The kit consists of nine 29" x 20" sheets (36 sq. ft.).

Insulation	409-027	\$159.99
------------	---------	----------



800-667-7872

\*See ordering page for details

WWW.MOSSMOTORS.COM



### Footwell Light Kit

Illuminating the footwell area of your car for entering and exiting makes the transition much safer. Can be wired to any 12V source. Kit includes two lights, wiring and instructions.

Footwell Light Kit 903-651 \$34.99



### Vintage Competition Belt

Quick release buckle with mounting hardware included. Sold individually.

Vintage Comp. Belt 222-211 \$134.99



### Seatbelt Shoulder Pads

Comfort, with a dash of color.

Pad with Red MG Logo, pair 231-300 \$27.99  
Pad with White MG Logo, pair 231-301 27.99

### Seat Heater

A little warmth in the right place can really make driving more comfortable. This therapeutic seat heater has dual zones and two settings to keep your bottom and lower back toasty. Designed to be installed under existing upholstery or seat covers, this kit is suitable for alternator equipped cars. Sold as a set for one seat.

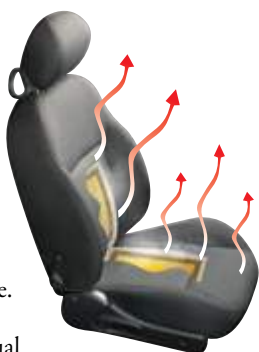

Seat Heater Kit 903-251 \$109.99

Beams seatbelts are made in the USA and exceed federal safety standards. Fire departments and amusement parks trust them, and we at Moss would not offer our customers anything less.



905-696

### Direct Replacement Seatbelt Kit

This complete kit includes all the hardware to correctly and safely mount new retractable 3-point seatbelts into the 1973-80 MG Midget. This is not a generic kit, or replacement belt, but a properly engineered kit with correct mounting hardware for the car.

1973-80 Midget 222-030 \$289.99  
Emblem, MG - Each 905-696 19.99



### Standard Seatbelt

Sold individually with alloy steel mounting hardware.

Standard Seatbelt 222-215 \$24.99



### 3-point Inertia Reel Seatbelt

Strapping on a seatbelt should be simple, but replacement inertia reel belts for pre-1976 Sprites and Midgets had short receivers. If the seat was moved forward, buckling was a struggle. Our new belt—officially wife approved—has a correct-sized receiver for all drivers. Belts are sold individually and include mounting hardware.

Black 3-point seatbelt 222-216 \$149.99



### Vintage Style Seatbelt

Black webbing with solid steel, chrome-plated aircraft style buckles. The substantial webbing length can be trimmed for safe operation. Mounting hardware included. Sold individually.

2-Point Belt, Short (38" adj. side, 20" tongue side) 222-234 \$28.99

3-Point Belt, Short (93" shoulder, 12" lap) 222-204 \$46.99

2-Point Belt, Long (38" adj. side, 30" tongue side) 222-235 \$29.99

3-Point Belt, Long (93" shoulder, 20" lap) 222-205 \$46.99

Emblem, Austin Healey - Each 905-686 19.99

Emblem, MG - Each 905-696 19.99



### Inertia Reel Seatbelt

Angle-sensitive belts are fussy, grabbing even if you're just parked on a hill. Inertia Reel Seatbelts grab when pulled rapidly—as they should. We have quality American-made inertia reel seatbelts, suitable for Sprites or Midgets. Black with a stalk mounted receiver similar to that originally fitted in 1973 and later cars, and will not fit earlier cars. Includes mounting hardware. Sold individually.

Black Seatbelt 222-025 \$99.99

### Inflatable Lumbar Support

This manually operated adjustable pneumatic lumbar support fits easily under the seat back upholstery of most cars. Once it's in place, simply pump it up.

Lumbar Support 650-100 \$64.99



# EXTERIOR

## A14 CAR COVERS



### Stormproof Embroidered

The culmination of over a decade of material engineering, it has only recently been possible to manufacture the microscopic yarns which go into this advanced micro-fiber cover material. Only one textile mill in the world was able to meet the specification - the results are truly a triumph for car cover users! Stormproof is uncoated and untreated, this means that even after months or years of use, it will retain the same properties as the day you purchased it! Stormproof has tested to be the most water-resistant and (because there are no coatings) the most breathable car cover material you can buy. You can't go wrong with Stormproof.

Sprite/Midget (not 1500)	237-465	\$259.99
Midget 1500	237-475	259.99



### Mosom Plus

Mosom Plus is a four-layer material. The outer two layers are Spunbond Polypropylene, the middle layer is a special micro-porous film and the inside layer is super soft fabric. The middle layer is an excellent rain barrier, but still allows vapors to pass through. The special cotton flock inner layer pampers the most delicate paint finish. It is a great choice for all-around car cover use, suggested for most conditions except extreme sun, snow or ice. Mosom Plus is a non-woven material, so in the unlikely event a rip occurs in the material, it will not run.

Sprite/Midget (not 1500)	237-460	\$94.99
Midget 1500	237-470	109.99

### Car Cover Accessories

Grommet	237-495	\$0.69
Cable Lock	643-855	7.99
Stowage Bag	643-850	7.99

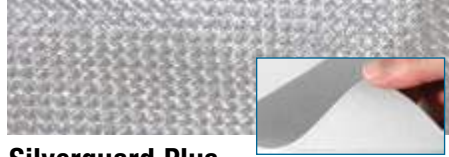

### Silverguard Plus

Silverguard Plus is a 300 Denier polyester material with a reflective, water-resistant coating on the outer layer and a soft, non-abrasive layer on the inside. It is a great choice for areas that get harsh sunlight. It is not suggested for extreme rain, snow or ice. 300 Denier is a strong, heavy weave, which will not rip or tear easily. The silver coating on Silverguard Plus does an excellent job of reflecting sunlight, therefore protecting your top, rubber seals and interior from premature wear. The special soft inner layer pampers the most delicate paint finish.

Sprite/Midget (not 1500)	237-461	\$149.99
Midget 1500	237-471	149.99

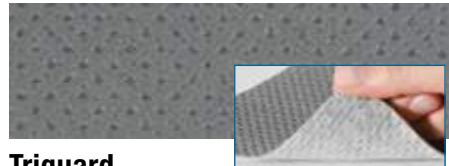

### Triguard

Cost-effective, universal-fit car covers can be used both indoors and outdoors to protect against dust and debris.

Triguard Car Cover	236-446	\$59.99
--------------------	---------	---------



### Interior Cover

You don't have to raise the top or use your car cover. Slip on an interior cover and protect your interior from sun damage and heat build up. Saves your interior from cracking and fading.

Sprite/Midget 1969-78	237-815	\$66.99
-----------------------	---------	---------

Features	STORMPROOF	SILVERGUARD PLUS	MOSOM PLUS	TRIGUARD
WATER RESISTANCE	◆◆◆◆	◆◆◆◆	◆◆◆◆	◆◆
BREATHABILITY	◆◆◆◆	◆◆	◆◆◆	◆◆◆◆
COMPACTNESS	◆◆◆◆	◆◆◆◆	◆◆	◆◆◆
UV RESISTANCE	◆◆◆◆	◆◆◆◆	◆◆◆	◆◆
HAZARDS	◆◆◆◆	◆◆◆◆	◆◆◆	◆◆
SOFTNESS	◆◆◆◆	◆◆◆	◆◆◆◆◆	◆◆◆◆

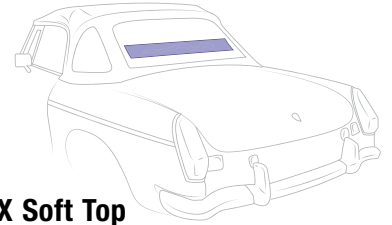

### Lamin-X Soft Top Window Repair Strip

If you have a cut or crack in the plastic window of your convertible top, then we have a perfect repair solution to keep it from getting worse. This 2" x 24" strip of 19 mil clear has 3.5 mils of adhesive that bonds to the clear plastic perfectly. It creates a strong, waterproof seal and is transparent enough that you won't notice it at a distance. Instructions are included.

Lamin-X Soft Top Window Repair Strip - 2" x 24"	910-475	\$12.99
---	---------	---------



### Car Capsule

Keep your car dust free, clean, dry, and protected from rodents, insects, scratches and other dangers. Park the vehicle on the laminated rubber base mat (which is impervious to gas and oil), zip the clear 8 mil. PVC double-sewn cover over the car, and plug in the fan which provides continuous airflow to prevent corrosion, mildew, and musty odors. Short or long term storage. Car Capsule operates for under \$1.50 per month. Two year material and craftsmanship guarantee. Fan motor is rated for five years of continuous running.

14' Indoor Car Capsule	238-600	\$499.99
16' Indoor Car Capsule	238-610	519.99
18' Outdoor Capsule	238-615	949.99



### Lift-the-Dot Hand Punch

Aimed at professional installers, this tool would make a fine car club tool box addition. Punches center hole and prong holes for installation of Lift-the-Dot fasteners to make installation of tops and tonneau covers a cinch.

Hand Punch	226-105	\$74.99
------------	---------	---------



800-667-7872

\*See ordering page for details

WWW.MOSSMOTORS.COM

# EXTERIOR

TOPS & TONNEAU COVERS **A15**



## Snap Installation Tool

Install button snaps without damage.

Snap Tool 386-980 \$5.79

## Tops

Includes all necessary snaps and fasteners. Header rail and rear anchor bar are not included.



Fixed Window  
Zippered Window

		Stayfast Cloth				Vinyl					
		Black	Price	Tan	Price	Black	Price	Tan	Price	White	Price
Bugeye w/shield studs	✓	242-181 <sup>1</sup>	\$723.99	242-182 <sup>1</sup>	\$723.99	242-180	\$349.99	242-183 <sup>1</sup>	\$349.99	242-184 <sup>1</sup>	\$349.99
Bugeye w/shield rod	✓	242-186 <sup>1</sup>	723.99	242-187 <sup>1</sup>	723.99	242-185	349.99	242-188 <sup>1</sup>	349.99	242-189 <sup>1</sup>	349.99
1962 on w/Side Curtains	✓	242-191 <sup>1</sup>	699.99	242-192 <sup>1</sup>	659.99	242-190	359.99	242-193 <sup>1</sup>	359.99	242-194 <sup>1</sup>	359.99
1964-66 (winding window)	✓	242-196 <sup>1</sup>	699.99	242-197 <sup>1</sup>	699.99	242-195	359.99	242-198 <sup>1</sup>	359.99	242-199 <sup>1</sup>	359.99
1967-69 (8 studs)	✓	242-176 <sup>1</sup>	699.99	242-177 <sup>1</sup>	699.99	242-175	356.99	242-178 <sup>1</sup>	356.99	242-179 <sup>1</sup>	356.99
1969-80 (6 studs & velcro)	✓	242-201	699.99	242-202 <sup>1</sup>	699.99	242-200	359.99	242-203 <sup>1</sup>	359.99	242-204 <sup>1</sup>	359.99
1969-80 (6 studs & velcro)	✓	242-375	799.99	242-376 <sup>1</sup>	799.99	242-370	456.99	242-372 <sup>1</sup>	456.99	242-371 <sup>1</sup>	456.99

<sup>1</sup>Special order, allow 6-10 weeks for delivery.

## OEM Type Top w/Header Rail - Made In England

	Vinyl	
	Black Vinyl	Price
1969-80 w/Header Rail	242-205	\$799.99



## Side Curtains

Fit your Sprite or Midget with a set of our factory style side curtains, complete with sealing strips, brackets and screws. Just like the original, these side curtains look great while keeping out the wind, the cold and the rain.

Side Curtain Set, Alloy Frame	259-678	\$559.99
Bracket Set with nuts & bolts	259-675	34.99
Outer Seal, L/H	282-455	18.89
Outer Seal, R/H	282-465	18.89
Screws, side curtain mounting	401-690	5.79



## Tonneau Covers

Tonneau covers are the time tested method of protecting your car's interior. Includes all necessary snaps and fasteners. Stayfast is an acrylic canvas which is flexible over a wide temperature range, yet is waterproof, and resistant to sagging, billowing, shrinking and fading.



	Stayfast Cloth				Vinyl	
	Black	Price	Tan	Price	Black	Price
Bugeye	241-271 <sup>1</sup>	\$686.99	241-272 <sup>1</sup>	\$687.99	241-270	\$299.99
1961-64 with Side Curtains	241-281 <sup>1</sup>	646.99	241-282 <sup>1</sup>	646.99	241-280	329.99
1964-66 (winding window)	241-286f	709.99	241-287f	709.99	241-285	365.99
1967-80 without headrests	241-291 <sup>1</sup>	699.99	241-292 <sup>1</sup>	699.99	241-290	356.99
1967-80 with headrests	241-301 <sup>1</sup>	709.99	241-302 <sup>1</sup>	709.99	241-300	365.99

<sup>1</sup>Special order, allow 6-10 weeks for delivery.

800-667-7872



WWW.MOSSMOTORS.COM

MOSS

# EXTERIOR

## A16 MIRRORS

### Brooklands Racing Screen

Reproduction of the traditional Brooklands racing screen. Screen includes a polished aluminum frame, safety glass and chrome plated brass mounting hardware.

Brooklands Screen 224-100 \$114.99

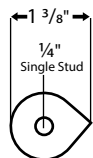

165-400/165-500  
165-210/165-300

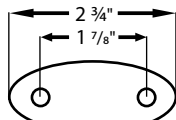

223-310

### Lucas Style Reproduction Mirrors

Flat Fender Mount	223-310	\$24.79
R/H Flat Lens	165-400	19.49
L/H Flat Lens	165-500	19.49
R/H Convex Lens	165-210	22.99
L/H Convex Lens	165-300	22.99

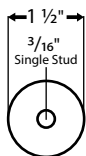

222-355



### Raydyot Racing Mirrors

Raydyot mirrors were often bolted to racing and performance cars in the 1950s and 1960s. Their brushed aluminum design was extremely lightweight and strong. Less weight will forever be the aim of speed seekers. The mirror's low mass led to another important advantage, too: they were stable and vibration-free. Moss has captured not only the distinctive look and character of the original Raydyot mirror, our aluminum reproductions also share the performance advantage of being light and strong. You may select mirrors with either the traditional flat lenses, or wide angle convex.

Raydyot Mirrors - Flat	222-355	\$49.99
Raydyot Mirror - Convex	222-356	49.99

### Baby Turbo Mirror

High-quality new production of this popular mirror from the 80s. The design still looks fresh and gives an updated look. Reversible mount for LH or RH use.

Baby Turbo Mirror 165-350 \$129.99

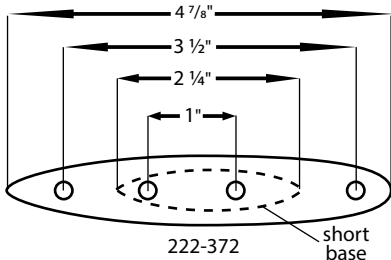

222-372

### Bullet Mirrors

The combination mirror has two base options. Short base is 2 1/4" with bolt holes 1" apart. Long base is 4 7/8" with bolt holes 3 1/2" apart. The oversize lens mirror has a base 3" long, bolt holes 1" apart.

Combination Mirror	222-372	\$59.99
Oversize Lens	222-390	59.99

### Leather Bonnet Straps

Bonnet Straps began life as a safety measure for racers. Daily drivers loved the look and added them to their sports cars. Our authentic reproductions are sold individually or in pairs and are a cinch to install.

Tan Leather, Pair	222-728	\$56.99
Tan Leather, Each	222-729	35.99
Black Leather, Pair	222-602	56.99
Black Leather, Each	222-601	35.99



### Quarter Light Mirror

This popular option can be clamped to a quarter light, windshield frame or roof lip to give better visibility.

Quarter Light Mirror 165-175 \$42.99

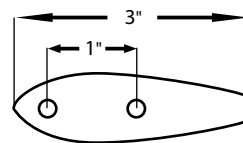

222-390



800-667-7872

\*See ordering page for details

WWW.MOSSMOTORS.COM





TOURIST TROPHY®

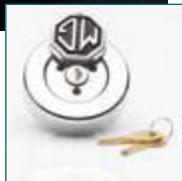

### Chrome Locking Gas Cap with MG Logo by Tourist Trophy

Thwart possible gas thieves and look great in the process! Add some security to your Midget while infusing style with this beautifully chromed gas cap adorned with the MG logo. This modern day gas cap uses the best materials to ensure it lasts longer than you do! The outside base is chromed stainless steel while the swiveling MG emblem is cast from Zinc-Aluminum for superb chrome adhesion and shine. This cap has been tested in a mixture of 75% gasoline and 25% methanol to ensure compatibility with all fuels. Supplied with 2 keys.

Midget 1970 On 202-780 \$129.99



### Locking Gas Cap

Chrome locking fuel filler cap. Includes two keys. Fits thru 1969.

Locking Gas Cap 202-760 \$37.99



### Aston Gas Cap

Features include quick release and easy installation. This chrome Aston gas cap is theft proof. Fits thru 1969.

1962-69 - Chrome 117-462 \$154.99



### Three Piece Master Lock Set

Replaces both doors and trunk lock assembly with matching key.

Three Piece Master Lock Set 470-458 \$99.99

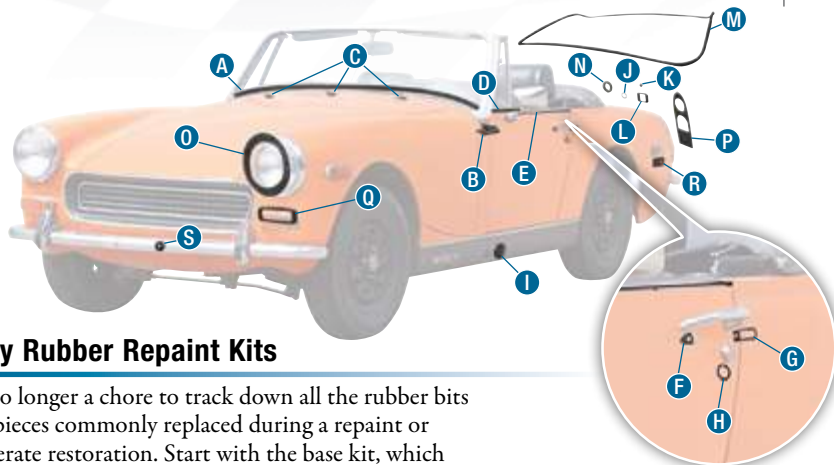

### Body Rubber Repaint Kits

It's no longer a chore to track down all the rubber bits and pieces commonly replaced during a repaint or moderate restoration. Start with the base kit, which contains the pieces common to all Sprite/Midgets, then add the supplemental kit specific to your year. That's all there is to it. See tables for specific content.

Base Kit - Roll-Up Window Cars	282-835	\$79.99
Base Kit - Side-Curtain Cars (Except Bugeye)	282-834	36.99
Supplement Kit - 1961-69	282-836	19.99
Supplement Kit - 1970-74	282-837	46.99
Supplement Kit - 1975-80	282-838	39.99

Body Rubber Kit Contents	
Base Kit - Side Curtain (Except Bugeye)	A, B, C (x2), I, J, K, M, N
Base Kit - Roll-up Windows	A, B, C (x3), D, E, F, G, H, I, J, K, L, M, N
1961-69 Supplemental Kit	O, P, Q, S
1970-74 Supplemental Kit	O, P, Q, R, S
1975-80 Supplemental Kit	I, O, P, R

III	Description	QTY
A	Windshield to Body Seal	1
B	Windshield Post Pads	2
C	Wiper Bezel Pads	1
D	Vent Window to Body Pads	2
E	Door Top Seals	2
F	Door Handle Gasket - Small	2
G	Door Handle Gasket - Large	2
H	Door Lock Gasket	2
I	Jack Hole Plug	2
J	Trunk Lock Gasket	1
K	License Lamp Wiring Grommet	2
L	Reverse Lamp Pads	2
M	Trunk Seal	1
N	Gas Filler Neck Grommet	1
O	Headlamp Seals	2
P	Taillamp Gaskets	2
Q	Front Park Lamp Gaskets	2
R	Rear Sidelamp Base Rubber	2
S	Front Bumper Mount Grommets	2



### Radio Antennas

**Electric Retractable Antenna:** Our electric antenna kit wires into your radio for fully automatic operation. Requires 1 3/8" depth to mount.

**Flush-Fit Antenna:** This collapsible antenna locks when down. Requires 1 1/4" depth to mount.

**14" Rubber Antenna:** Black. Includes 54" lead cable.

Electric Antenna	386-960	\$109.99
Flush-Fit Antenna	386-971	15.99
Rubber Antenna	900-716	14.79



### Raked Shorty Antenna

Small and powerful-that's the right combination. At a mere 7 inches tall and with a swept back look, our amplified antenna is a major design improvement over an unsightly standard mast or a noisy old power antenna. Comes with a 195" detachable cable, and the mast easily unscrews if you have a car cover without a hole.

7" Amplified 906-185 \$32.99

# EXTERIOR

A18 RACKS & ACCESSORIES



## License Plate Frames

High-quality license plate frames to show off your car's heritage.

Union Jack, Black	222-735	\$44.99
Union Jack, Stainless	222-725	46.99
MG Safety Fast, Stainless	222-776	46.99
Sprite, Stainless	222-880 <sup>1</sup>	46.99
Midget, Black	222-850 <sup>1</sup>	44.99
Morris Garage, Stainless	222-830	46.99
Midget, Stainless	222-875 <sup>1</sup>	46.99
Checkerboard, Black	222-737	39.99

<sup>1</sup>Standard mounting hardware included.



## Decal & Plate Kit

### Sprite Mk1 (pictured)

Includes chassis, valve cover and heater plates. Screen washer reservoir, coil, air filter and wiring harness decals.

### Midget 1961-66

Includes chassis and heater plates. Screen washer reservoir, valve cover, trip odometer, and air filter decals.

### Midget 1967-69

Includes chassis and heater plates. Screen washer reservoir, valve cover, trip odometer, convertible top, radiator and air filter decals.

Sprite Mk1	410-110	\$33.99
Midget 1961-66	410-190	24.99
Midget 1967-69	410-195	24.99



Hear about the latest news, first.



229-730

229-735

## License Plates

Display your loyalty with one of our regulation size license plates. Embossed aluminum plates with crisp screen printing.

Union Jack	229-730	\$9.99
MG Octagon	229-735	9.99



## Bugeye Luggage Rack

Factory style rear luggage rack. Features strap mounting tabs. Measures 30½" x 16".

Bugeye Luggage Rack	244-720	\$409.99
---------------------	---------	----------

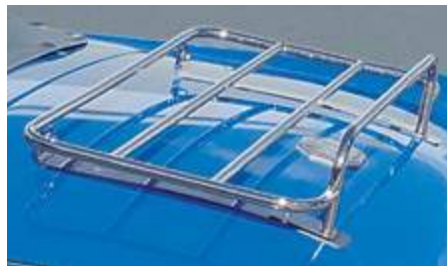

## Sprite/Midget Luggage Rack

This stainless steel beauty measures 34½" x 15". Fits all except Bugeye.

Luggage Rack	244-730	\$349.99
--------------	---------	----------

# MOSS

MORE INFO ONLINE

## Pressed English License Plates

Regulation British plates are identical to those used in England in the 40s, 50s and early 60s. Semi-sheared raised letters. Up to seven letters and numbers of your choice.

English Plates	307-073	\$89.99
----------------	---------	---------



## Stainless License Plate Support

Add a touch of sparkle to your ride. Polished stainless steel resists corrosion and brightens up later rubber bumper Midgets.

License Plate Support	451-296	\$43.99
-----------------------	---------	---------



## License Plate Mount Badge Holder

Have a license plate on your car? Want to run a badge or two? This badge holder is designed to mount to the upper or lower license plate mounting screws, and accepts both standard back mount and magnetic badges!

Badge Holder - License Plate Mount	244-105	\$28.99
------------------------------------	---------	---------



## Twin Air Horns

Our twin tuned air horn set includes two tuned air horns, heavy duty die cast compressor, air hose, mounting hardware and installation instructions.

Horns	545-080	\$54.99
-------	---------	---------



## Lucas Style Windtone Horns

A Moss exclusive - our reproduction of the original Lucas Windtone horns is the best available. As originally fitted to many early MGs, Triumphs and Jaguars. Set of two horns includes high and low note. Requires bracket #405-800 for an easy installation. Set of two.

Windtone Horns	165-708	\$99.99
----------------	---------	---------

MOSS

800-667-7872

\*See ordering page for details

WWW.MOSSMOTORS.COM



## Grille Badges

Solid baked enamel finish on a polished stainless steel back.

(1) Great Britain	408-506	\$23.99
(2) England	408-507	23.99
(3) U.S.A.	408-527	23.99
(4) RAC	408-547	23.99
(5) U. S. Coat of Arms	408-529	23.99
(6) MG	408-487	23.99
(7) Austin-Healey	408-457	23.99
(8) Abingdon-On-Thames	408-186	34.99
Badge Bar Mounting Backing Plate	408-577	8.99
Badge Mounting Kit - 1" Bar	408-001	6.99
Badge Mounting Kit - ¾" Bar	408-002	7.99

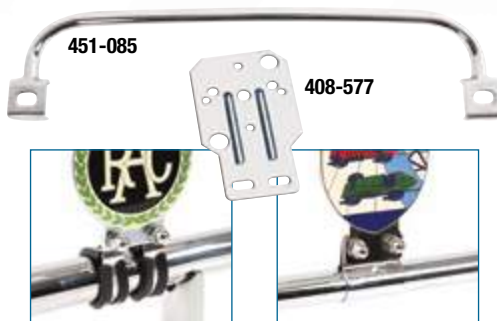

## Badge Bars & Mounting Hardware

Dress up the front of your car. Badge bars do not fit Bugeye or Midget 1500.

Sprite/Midget	451-085	\$84.99
Sprite/Midget w/fog lamp mounts	451-075	154.99
Badge Bar Mounting Backing Plate	408-577	8.99
Badge Mounting Kit - ¾" Bar	408-002	7.99
Badge Mounting Kit - 1" Bar	408-001	6.99



470-686

470-687

## British Leyland Badges

We took original samples and matched both the color and the design to get accurate reproductions of the two most popular versions of these emblems. Both feature self-adhesive backing for easy installation on the original fender location. In 1972 the cast version was introduced and was typically seen on the left hand fender of LHD cars.

Silkscreened, 1970-71	470-687	\$5.89
Cast, 1972 on	470-686	9.99



408-001

408-002

## Badge Bar Badges

(1) Cloisonné RAC	408-517	\$54.99
(2) RAC Badge	408-695	79.99
(3) St. Christopher	408-435	106.99
(4) Brooklands	408-175	66.99
Badge Mounting Kit - ¾" Bar	408-002	7.99
Badge Mounting Kit - 1" Bar	408-001	6.99



## Twin Trumpet Horn Kit by Hella

The Twin Trumpet Horn Kit by Hella produces a full harmonious and wide sound radiation. They are noticeably louder than stock horns and have been manufactured to the highest standard. This kit includes both a high and low note horn, relay, mounting brackets and instructions.

Twin Trumpet Horn Kit	545-095	\$28.99
-----------------------	---------	---------



## Super Tone Horn Kit by Hella

Compact and powerfully loud, a proper horn is more than an accessory, it's a safety measure all British cars should have. Our high quality horn upgrades are simple to install, sound great and definitely turn heads with their volume.

Super Tone Horn Kit	545-090	\$48.99
---------------------	---------	---------

## Compact Air Horn Kit

Very compact yet very loud! Tired of modern (huge) traffic not noticing your classic (small) sports car on the highway? This kit fits in a space 5½" x 4½" x 4" (LxWxD) and produces deep tones of 115 db at 6 feet. A perfect solution for your compact classic. Kit comes with a relay, mounting bolt and nut and instructions.

Compact Air Horn Kit	545-085	\$62.99
----------------------	---------	---------



# EXTERIOR

## A20 ACCESSORIES

### Chrome Reverse Lamp Rims

The original reverse lamp lenses have never been a thing of beauty, now that can be changed. These chrome plated brass rims fit over the original lens to brighten the rear of the car. Available individually or as a set of two with new lenses, and installation screws.

Chrome Rim 164-862 \$19.99  
 Chrome Rim & Lens, Complete Car Set 164-868 49.99



### LED Tail Light Kit

By owning older cars, we make compromises with modern safety in several ways, often with no apparent regret. One risk, however, no one would compromise on: getting hit from behind because our brake lights weren't visible enough. LEDs are a modern technology we can all get behind. Other than the need to drill a couple small holes, there are no drawbacks. And the immediate, intense light LEDs produce transform your brake lights and turn signals from wispy candles to high-powered beams. For negative ground vehicles only.

Bugeye Sprite 143-810 \$99.99



### Rear Fog and Reverse Lamps

These matched lamps have polished stainless steel cases, glass lenses and 20W H3 type halogen light bulbs. 4½" wide, 2¼" high. ⅝" mounting hole required. Suitable for mounting below the rear bumper. Check your local regulations to make sure they are legal for street use. Sold individually.

Reverse Lamp, Clear 162-842 \$49.99  
 Rear Fog Lamp, Red 162-843 49.99

### 3rd Brake Light Kit

Center-mounted 3rd brake lights reduce accidents, so much so that they have been required on all passenger autos built since 1984. Our old cars, with two dim, low mounted brake lights, aren't exactly easy to see. With a little creative wiring, you can mount one of our brilliant accessory 3rd brake light kits and improve the safety of your British classic. The base can be removed for flush mounting.

Chrome Brake Light Kit 116-115 \$89.99



### Headlamp Stone Guards

Heavy duty chrome-plated wire mesh stone guards protect your headlights. May not be street legal. Includes hardware not shown.

Stone Guards 222-100 \$10.89

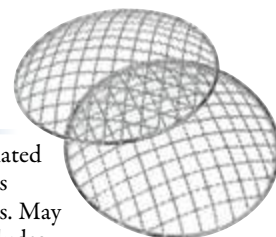

### LED Exterior Lighting

We've had our eyes on these for a while now. We couldn't help it, they're so bright! Our LEDs have the advantage of a wide-angle light distribution design. And, best of all, you can install these yourself. These bulbs fit factory sockets, but require that your car be negative ground. After much searching and testing of different products, we can now say that Moss offers an LED lighting solution that measures up to our requirements.

#### Our LEDs come in three colors

White, red and amber—to match the color of the lens application. Trust us, you don't want a white light behind a red lens. Pink is not the universal color for "stop," last we checked.

#### Upgraded Electronic Flasher

If you are upgrading any of your turn signals you will need to upgrade to an electronic flasher. The LED bulbs draw so little current that they won't trigger a mechanical flasher to blink.

#### Do I need ballasts with my LED turn signals?

This is not an issue in all Classic British cars. Because of the LEDs low current draw, the tiny amount of current circulating from one side of the car to the other will be enough to let the LEDs on the second side of the car come to life. Blinking turns to hazard lighting and that's not what you want. The fix is simple. The power flowing through the blinker indicator lamp is looking for a ground. We give it one. A ballast resistor is a simple electronic device designed to give the indicator the ground it's looking for without leaving any extra for the opposite LEDs to feed on. You will need one for each side of the car. The application data in our catalog and on our website will tell you if your car needs a pair of ballasts.



Industry #	57	89	1157	1156
Replaces Moss #	170-100, 170-250	170-300	170-700	170-800
White	170-906	170-920	170-931	170-946
Amber	170-911	170-921	170-936	170-951
Red	170-916	170-925	170-941	170-956
Price	<b>\$18.99</b>	<b>\$15.99</b>	<b>\$24.99</b>	<b>\$25.99</b>

#### Electronic Flashers

2-Prong 141-667 \$20.99  
 3-Prong 141-668 22.99

#### Ballast Resistor

Spridget 1972-on 170-965 \$15.99



170-941 170-956



170-906 170-920



800-667-7872

\*See ordering page for details

WWW.MOSSMOTORS.COM



## Hella 500 Light Kits

Light up the road with these Hella 500 Light Kits. The Driving Light kit emits a focused beam for long-range illumination, while the Fog Light kit projects a wide, low, illumination perfect for foggy or dusty conditions. Kits include: 2 halogen lamps, two H3 12V/55W bulbs, 2 protective stone shields, plug-n-play harness, 1 switch, 1 12V relay, and instructions. Lamp dimensions: 6.8" h x 6.4" w x 2.6" d.

Driving Lights	162-780	\$114.99
Fog Lights	162-785	119.99



## Crystal Clear Headlamp

For a modern look, we offer Crystal Clear headlights with halogen H4 bulbs. These are DOT and SAE approved and deliver a strong focused light. The cast aluminum housing is corrosion-resistant and the lens is vented to prevent fogging. Sold individually.

Crystal Clear Headlamp, each	156-875	\$39.99
Replacement H4 Bulb	902-998	5.99



## P700 Tripod Headlamp Set

The P700 was a step up from the standard headlamp and featured an internal tripod reflector with round center cap; our reproductions capture the look and vintage design of these lamps at a much lower price. These lamps are an entry-level alternative to our 156-898 PL700.

P700 Tripod Set	156-878	\$139.99
Replacement Bulb, each	170-600	8.99

**Lucas**

## Lucas 7" Halogen Headlamp

Made by Lucas, these high-quality headlamps come with replaceable H4 bulbs. Fits all regular 7" headlamp applications.

Lucas Headlamp, each	162-726	\$46.99
Replacement H4 Bulb	902-998	5.99



## Hella Halogen Headlamp

Accurate optics and reflector put the light where it is needed. Safe for all vehicles originally equipped with 7" sealed beam headlamps. Sold individually.

Hella Halogen Headlamp, each	902-969	\$74.99
Replacement H4 Bulb	902-998	5.99



## Headlamp Relay Kit

Any British classic can benefit from adding headlamp relays. Your headlights will be significantly brighter, and the useful life of the lighting switch will be extended considerably with this easy-to-install kit. Relays are especially beneficial (and strongly recommended) if you have fitted halogen headlamps.

Headlamp Relay Kit	117-515	\$38.99
--------------------	---------	---------



## Lamin-X Headlamp Shield

No matter where you lie on the spectrum of LBC upkeep, we offer the security of Lamin-X, a thin, invisible layer that protects headlamps from stone chips and scratches, and keeps your lights looking new for years to come. Installation takes 10 minutes. Fits all 7" round headlamps. Sold in pairs.

Headlamp Shield, pair	162-695	\$24.99
-----------------------	---------	---------

## Fog and Driving Lamps

Quality reproductions of the classic 5 1/2" Lucas 500 series SLR and SFT lamps as originally fitted to many cars of the 50s and 60s. Lamps are sold individually.



### Driving Lamps

Stem Mount	162-700	\$149.99
Back Mount	162-760	149.99

### Fog Lamps

Stem Mount	162-800	\$149.99
Back Mount	162-770	149.99

### Lamp Covers

6" dia. fits above 500 series	162-705	\$89.99
7" dia. fits Lucas 700 series	162-865	84.99

### Replacement Bulbs

Driving Lamp Bulb	170-500	\$5.89
Fog Lamp Bulb	170-510	4.19

## PL700 Tripod Headlamp Set

The PL700 was fitted to many high-end sports cars. The unique lens design and prominent PL badge give a distinct look that is part of the historical heritage of our cars. These lamps are reputed to have been made on original tooling, but the quality of the lens silvering and detailing is not as crisp as original samples we have of the PL lamp.

PL700 Tripod Set	156-898	\$179.99
Replacement Bulb, each	170-450	3.49
Bulb, quartz halogen, each	170-675	6.79



## Driving Lamp Clamp

These clamps can be used to mount 500 and 700 series fog or driving lamps to 3/4" badge bars. Plus they can be used for mounting antennas or other accessories.

Chrome Lamp Clamp	408-579	\$19.99
-------------------	---------	---------

## 1962-74 Alloy Headlamp Rim

For the weight conscious, or just to be different, we now offer lightweight alloy headlamp rims. Sold individually.

Alloy Headlamp Rim	560-211	\$41.99
--------------------	---------	---------



# WHEELS

## A22 KNOCKOFFS & TOOLS

### Knockoffs

Choose the original 2-eared style, or the more exotic 3-eared style. Earlier cars have fine 12 threads per inch, later cars use a coarser 8 threads per inch. Our MG crested knockoffs were original equipment on MGT and MGA, but would look great on your Midget.

#### MG Crested 2-Eared Knockoffs

Fine Thread 12 t.p.i. - Left Hand	200-220	\$47.99
Fine Thread 12 t.p.i. - Right Hand	200-210	47.99
Coarse Thread 8 t.p.i. - Left Hand	200-225	47.99
Coarse Thread 8 t.p.i. - Right Hand	200-215	47.99



#### Standard 2-Eared Knockoffs

Fine Thread 12 t.p.i. - Left Hand	200-280	\$47.99
Fine Thread 12 t.p.i. - Right Hand	200-290	47.99
Coarse Thread 8 t.p.i. - Left Hand	674-680	47.99
Coarse Thread 8 t.p.i. - Right Hand	674-670	47.99



#### 3-eared Knockoffs

Fine Thread 12 t.p.i. - Left Hand	200-315	\$86.99
Fine Thread 12 t.p.i. - Right Hand	200-325	86.99
Coarse Thread 8 t.p.i. - Left Hand	200-335	89.99
Coarse Thread 8 t.p.i. - Right Hand	200-345	89.99



### Wheel Trim Rings

Polished stainless steel to provide an attractive accent to your rims. Sold in a set of 4. For Rostyle wheels only.

13" Trim Rings - Set of 4	453-048	\$113.99
---------------------------	---------	----------



### Knockoff Hammers

All types, weights and sizes for every possible application.

1 lb. Copper/Copper	386-000	\$46.99
2 lb. Copper/Copper	386-850	49.99
2 lb. Copper/Rawhide	386-110	57.99
4 lb. Lead Alloy	386-180	64.99



### Inner Tubes & Rim Bands

Designed for use with radial tires. Can be used with bias-ply tires. Features rubber covered valve stems. Rim bands prevent spoke and nipple ends from chafing your inner tubes. All sold individually.

#### Inner Tubes

145 x 13"	452-736	\$19.99
-----------	---------	---------

#### Rim Bands

13" Rim Band	452-730	\$9.69
--------------	---------	--------



### Long Handle Knockoff Wrench

Long handle wrench allows you to tighten or remove spinners without a hammer.

Octagon Knockoffs	386-120	\$53.99
Eared Knockoffs	386-125	53.99
Fabric Wrench Cover	386-115	21.99



### Wire Wheel Spoke Wrench

With its wide face and long handle, this wrench is perfect for adjusting most spoke nipples without rounding them off.

Spoke Wrench	385-800	\$10.29
--------------	---------	---------



### Protective Knockoff Wrenches

Prevent damage to knockoffs with multiply wooden wrenches. Fits all 42 mm conventional British two eared knockoffs.

Protective Wrench	386-165	\$29.89
-------------------	---------	---------



### Brass Tire Gauge

Solid brass precision gear movement. Push button valve to bleed air to the desired pressure. U.S. and metric scales.

Brass Gauge	225-715	\$19.99
-------------	---------	---------



### Valve Stem Caps

Further dress up those chrome wheels with a set of valve stem caps with logos. Set of 4.

Union Jack - Non-Locking	101-161	\$13.99
Checkerboard - Non-Locking	101-167	13.99



### MG Embossed Valve Stem Cap

Subtle and elegant, these nickel-plated steel valve stem caps feature an MG crest embossed in the top. Sold individually.

MG Valve Stem Cap	215-825	\$9.99
-------------------	---------	--------



### Spare Tire Cover

Sturdily constructed from high-quality vinyl, this spare tire cover will not only clean up the look of your trunk, but stand up to pretty much everything you throw at it.

Spare Tire Cover - Black	242-856	\$84.99
--------------------------	---------	---------



800-667-7872

\*See ordering page for details

WWW.MOSSMOTORS.COM

### Wire Wheels

An essential part of your Sprite or Midget's styling. Whether standard or not, a set of chrome wire wheels truly enhances the appearance of your car.

Dia/Width	Spokes	Finish	Unit	Part #	Price
13" x 4"	60	Chrome	Each	454-685	\$355.99
13" x 4"	60	Painted	Each	454-675	259.99

#### Inner Tubes For Wire Wheels

145 x 13" Tube	452-736	\$19.99
----------------	---------	---------



[MORE INFO ONLINE](#)



### Wire Wheel Conversion Kit

Owners have been converting disc wheels to wire wheels for decades. Our kit makes that conversion a snap!

The kit includes 4 hubs (2 left, 2 right), 4 chrome knockoffs, 16 nuts, 1 hammer and 2 spacers for Bugeye Sprites.

Wire Wheel Conversion Kit 111-425 \$594.99



453-065

453-066

### Minilite Style Sport Wheels

Manufactured using the latest techniques and testing procedures to ensure the highest quality. These wheels carry on the race and rally tradition of the marque.

13" x 5" Sprite/Midget - Silver	453-065	\$159.99
13" x 5" Sprite/Midget - Anthracite	453-066	169.99
Replacement Hub Cap - Metal	455-367	16.99
Replacement Hub Cap - Chrome	456-049	10.99
Lug Nut, Chrome	264-155	2.79
Lug Nut, Stainless Steel	264-156	8.99
Lug Nut, MG Crest	264-465	3.79
A-H Emblem for Center Cap	453-067	2.99
MG Emblem for Center Cap	455-377	2.99



### Minilite Style Knockoff Wheels

Designed to replicate the famous racing wheel of the past, this 13" knockoff "Minilite" replica wheel will fit wire wheel hub equipped cars with round rear wheel arches. Please note tire clearance will be tight with some tire sizes.

13" x 5" Bugeye & Round Arch Cars 453-081 \$464.99

# PERFORMANCE

A24 SUPERCHARGERS



**INCREASE!**  
**23** | **25**  
horsepower | ft. lbs. of torque

## 1275cc Supercharger System

The Moss Motors designed supercharger system uses the same Eaton positive displacement Roots type supercharger found on contemporary applications such as Jaguar and Mercedes Benz. Designed to fit the 1275cc engine, the kit will work with either generator or alternator equipped applications. The

extra loading will reduce the life of generator bearings, so we also offer an alternator upgrade kit. Our engineers designed an intake manifold that provides equal airflow, pressure and fuel mixture to each cylinder. This careful design works with the supercharger to increase torque even at idle. The latest generation Eaton

blower features an internal bypass system that improves operating efficiency and reduces fuel consumption by allowing the boosted mixture to re-circulate under low load conditions, cutting down on drag. The supercharger system is very complete and includes a 4 rib serpentine belt drive system with automatic adjustment. Carburetion is provided by the latest version of the SU HS6 and a K&N air filter is included to make the package complete. A new water pump, NGK spark plugs and very detailed instructions make installation a breeze.

A dramatically linear increase in torque and power produce a driving sensation without the drivability, cooling and fuel consumption problems normally found with traditional performance modifications. A competent mechanic or hobbyist can install the kit in about 8 hours.

### Dyno Test Results • 1972 MG Midget

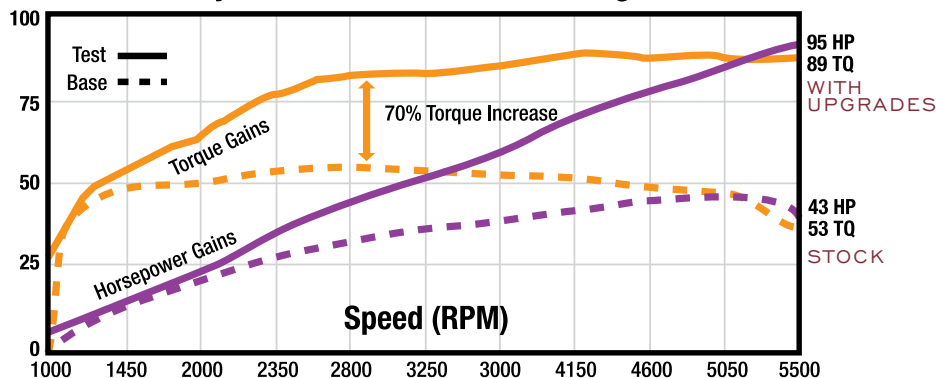

1275cc Supercharger System 150-080 \$3,895.00



800-667-7872

\*See ordering page for details

WWW.MOSSMOTORS.COM



**SUPERCHARGER UPGRADES**



**Alternator Conversion for Supercharged Engines**

If you have invested in a supercharger for your generator equipped car, but would now like to convert to alternator, this kit has all the parts and detailed instructions to make the conversion.

Alternator Conversion Kit 130-108 \$239.99



**Supercharger Heat Shield Kit**

Heat is the enemy when compressing the intake charge. We have developed a kit of high tech heatproof material and stainless steel shields to reduce the intake temperature dramatically. Installation requires removal of the supercharger from the engine. Fits supercharger kit 150-088

Heat Shield Kit 150-086 \$209.99



**Big Boost Kit**

Our supercharger kit was designed to get the most out of a stock engine. If you are ready to explore the boundaries of power, this upgrade kit has the parts necessary to step up a notch. Please note, installation of the included pulley will void the manufacturers warranty of the rotor group bearings.

Big Boost Kit 150-084 \$189.99

ADD **MUSCLE** TO YOUR **MIDGET**  
AND **SPIRIT** TO YOUR **SPRITE!**

Our Supercharger kit adds power to your Sprite or Midget - but what if you're looking for even more power? How about almost twice the power as stock? It's easy to bolt on the extra parts outlined below and get numbers that are close to our test mule. With twice as much power it's more like a jack rabbit than a mule! Follow our setup and put that same super-power into your Sprite or Midget:

**ADDITIONAL UPGRADES**



451-875  
Aluminum Cylinder Head **\$1,399.00**



460-505  
Sprite/Midget 948 **\$459.99**  
461-005  
Sprite/Midget 1275 **459.99**



460-385  
Vernier Cam Gear Kit **\$164.99**



222-555  
Pertronix Electronic Ignition **\$124.99**



322-998  
ARP Head Rocker Stud Kit **\$184.99**

322-838  
ARP Rod Bolt Kit **\$162.99**

322-888  
ARP Main Stud Kit **\$73.99**



452-017  
Stainless Steel Header **\$229.99**



235-878 Oil Cooler Installation Kit **\$189.99**

235-925 13 Row Oil Cooler **\$52.99**

# PERFORMANCE

**A26** ENGINE



## 1275 Alloy Crossflow Cylinder Head

Similar to the crossflow head from the '60s, this has an improved design, while using standard valve gear and valve guides. Larger diameter inlet ports (4) and crossflow design overcome the 'A' series engine breathing problems by increasing the inlet manifold air flow by as much as 20%, over an original 5 port head. Aluminum alloy is lighter, runs cooler and allows for higher compression ratios. Designed to fit in cramped engine bays when assembled with Webers, two #378-675 recommended. Bare heads come with silicon-bronze valve guides and hardened valve seats. Assembled heads also have valves and springs installed. Use 10mm Autolite 4303 spark plugs.

Crossflow Cylinder Head - Assembled	451-808	\$1,649.00	
Crossflow Cylinder Head - Bare	451-807	1,549.00	

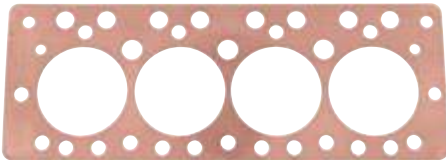

## Head Gasket

These are .032" thick solid copper. They can be modified for overbored engines and have been a secret ingredient of many high performance racing engines. Copper head gaskets are not recommended for use with alloy heads.

1275 387-520 \$134.99

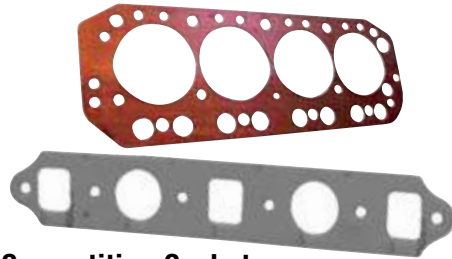

## Competition Gaskets

Highly recommended for use with high compression pistons and modified heads, the copper and asbestos head gasket is made to original British Leyland specifications. The special manifold gasket has enlarged holes to match inlet and exhaust ports on modified cylinder heads.

Head Gasket (1275)	694-555	\$17.99
Manifold Gasket (948-1275)	296-645	11.99

**MORE  
INFO  
ONLINE**



## Midget 1500 Bushed Rocker Arms

Originally the rocker arms were not bushed and tended to wear quickly. We have had bushed arms made for us by a UK supplier which are available individually ready to be honed to fit your rocker shaft, or as a matched honed set with rocker shaft. The rocker arms have a tip hardness of 50-52 HRC, as original and should have a clearance after honing of 0.002".

Arms (8) & Shaft Set	839-138	\$219.99
Odd Numbered Rocker Arms	839-115	16.99
Even Numbered Rocker Arms	839-125	16.99



## 1275 Alloy Cylinder Head

Light-weight (9 lbs.) high strength aluminum alloy cylinder heads run cooler, allow higher compression ratios, and have a greater than 35% increase in flow rate. Includes silicon-bronze valve guides and hardened valve seats. Requires 1275 valves, springs, retainers, and 12 mm spark plugs (use NGK #451-890) not included. Quantities required are in parentheses. These heads do not have air injection ports, and therefore may not be used for street use on cars originally fitted with air pumps.

Alloy Cylinder Head	451-875	\$1,399.00	
Head Gasket, Black - Payen	694-527	19.49	
Intake Valve (4)	423-190	4.79	
Exhaust Valve (4)	423-330	6.99	
Valve Spring Set (1)	423-470	25.89	
Valve Cotter (16)	460-535	2.09	
NGK Spark Plug (4)	451-890	4.99	

## Valve Cover Thumb Nuts

Improve the appearance and functionality of your engine compartment. For A-series engines only, not 1500. Set of two. Can't be used with alloy valve covers.

Chrome Thumb Nuts, pair	460-118	\$12.99
-------------------------	---------	---------

## 1275 Alloy Valve Spring Cap

Half the weight of steel.

Alloy Valve Cap - Each	460-557	\$29.99
------------------------	---------	---------



## Alloy Valve Covers

(A) 1961-74 Polished Ribbed	224-530	\$69.99
(B) Midget 1500 Polished Ribbed	224-550	74.99
(C) Midget 1500 Black Ribbed	224-560	99.99
Replacement Cap for A & B	460-145	12.39
Replacement Cap for C	852-120	27.99



## Silicone Valve Cover Gaskets by Gasket Innovations

These premium silicone valve cover gaskets are stronger and more resilient than traditional cork. They will tolerate re-use far better as well, allowing you to remove these covers repeatedly without having to replace your gaskets every time. Two types of gaskets are offered, one for Stock covers, and one for Alloy covers. Select your application below. Instructions included.

*Note: Red RTV Sealant is needed for proper installation.*

Sprite/Midget w/ Stock Valve Cover	296-006	\$18.99
Sprite/Midget w/ Alloy Valve Cover	296-007	22.99
A-Series Side Cover Gasket - Pair	296-377	27.99
Midget 1500 w/ Stock Valve Cover	694-101	19.99
Midget 1500 w/ Alloy Valve Cover	694-102	25.99
RTV Sealant - Red - 3oz.	221-305	7.49

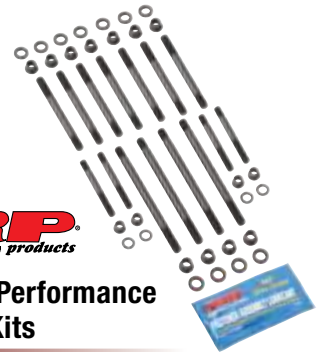

**ARP**  
automotive racing products

## ARP High Performance Fastener Kits

Manufactured from top grade 8740 chrome-moly steel. Tensile strength in the range of 200,000 psi. Threads rolled after heat treat to provide up to 10 times longer fatigue strength. Precision CNC machined to exact specifications.

Head Stud Kit 948-1275	322-998	\$184.99
Rod Bolt Kit 1275	322-838	162.99
Main Stud Kit 948-1275	322-888	73.99



800-667-7872

\*See ordering page for details

WWW.MOSSMOTORS.COM



## A-Series Performance Tappet Sets

The tappet takes the brunt of the punishment in the engine as it rides on a thin film of oil on the cam lobe. In an effort to offer the engine builder alternatives we carry a range of tested and uprated tappets for the 948 to 1275cc engines.

### Tested Tappet Sets

These tappets are inspected for dimensional accuracy, and then hardness tested to ensure a hardness of HRC 54-58. The face of the tappet is crowned slightly to ensure rotation and then polished. Finally the tappet is Parkerized for improved oil retention during startup. The lifter set is supplied with installation instructions and #221-565 assembly lube. These processes are time intensive, but result in a tappet that meets all known original specifications.

### APT Super Duty Tappet Sets

These tappets have a typical surface hardness above HRC 60 and feature an oil lubrication hole and precision ground face.

### Lightened Tappet Sets

These tappets are machined for a thinner sidewall and are drilled to reduce oil retention. Lightening the tappet reduces load on the cam and makes them suitable for high lift cams and/or high rpm.

Tappet Set, Tested, with Lube	460-604	\$199.99
Tappet Set, Super Duty, APT	460-601	199.99

## Super Duty Tappet Sets

Super duty tappets to fit Midget 1500 motors. Heat treated chilled cast iron with a manganese phosphate break-in coating. Hardness rated at 62-65 HRC. Drilled for oil drainage to reduce operating mass.



Midget 1500 838-306 \$169.99

## Alloy Rear Engine Plate

Light weight, high strength alloy plate reduces nose weight for competition use.



Midget 1500 832-545 \$99.99



Pressure fed oiling to lobes and distributor drive gear

## Performance Cams and Oil Pumps

We offer two performance street camshafts ground on new induction hardened steel billets with a finish ground hardness of 56-58 Rc. All cam lobes and the distributor drive gear are drilled for improved oil delivery. Both cams require upgrading to the latest slot type oil pump, which gives improved oil flow. **Both cams incorporate the latest valve timing theory to give the best performance for your driving style.** The Fast Road cam gives a smooth idle and is suitable for supercharged engines and use in city traffic. The Road/Rally cam is more suitable for open road driving, but can still be used around town.

*Note: For comparison purposes, duration is given at two different lifts. In the UK, .0158" cam lift is often used. In the US, cam lift of .050" is usually used.*

Duration @ .0158" cam lift	Duration @ .050" cam lift	Cam lobe lift	Valve lift gross (1.26 ratio)	Power Band	Part #	Price
257/257°	214/214°	0.270"	0.340"	1500-5500 rpm	114-160	\$569.99
270/270°	224/224°	0.280"	0.353"	1900-5800 rpm	114-165	569.99

### Matching Oil Pumps

High Output Slot Drive, 1275	114-039	\$56.99
Standard Slot Drive, 1275	114-034	33.99
Standard Slot Drive, 948-1098	114-040	29.99



## Adjustable Cam Sprocket Kit

Cam timing adjustment is crucial to performance. This adjustable cam sprocket kit built with unparalleled craftsmanship allows cam timing adjustments to your performance specifications. The kit, which converts your vehicle to a duplex timing chain, includes a heavy-duty adjustable cam sprocket, heavy-duty crank sprocket, a pre-stretched duplex timing chain, seal, locktab and timing cover gasket. Everything you need for a job well done.

948, 1098, 1275 460-386 \$249.99

## Vernier Cam Sprocket Kit

If you're serious about your engine rebuild, this is one upgrade you should be sure to install! Our kit includes the double row chain, crank sprocket, and fully adjustable cam sprocket.



948-1098-1275 460-385 \$164.99



114-034



114-039



297-660

## A-Series Rear Oil Seal Conversion Kits

Complete oil seal conversion kits for the A-Series engines. These kits require careful fitting to ensure that the rear cap packing piece is leak tight. The seal rides on the outer flywheel mounting flange and this must be smooth. No drilling or cutting is required and the crank does not have to be removed. Installation does require removal of the flywheel and engine back plate.

948, 1098 w/1.75" Mains	297-665	\$269.99
1098 with 2" Mains	297-660	259.99
1275	297-655	269.99
Repl. Oil Seal - 948, 1098 - 1.75"	297-666	29.99
Repl. Oil Seal - 1098 - 2"	297-661	35.99
Repl. Oil Seal - 1275	297-656	31.99

## Magnetic Oil Drain Plug

Magnetic drain plugs help protect your engine by collecting metallic particles before they get fed through the oil system.



948-1098-1275	328-282	\$16.79
Midget 1500	328-356	7.99

# PERFORMANCE

A28 ENGINE



## 5 Speed Conversion Kits

If you plan on driving your classic, installing a 5 speed transmission will make the car much more enjoyable at highway speeds. Using the popular Ford T9 gearbox, the installation is reversible with minimal modifications to the frame or transmission tunnel. Get better fuel economy, less engine wear and easier shifts.

The 5 speed kits come complete with the following components:

- Reconditioned Ford T9 Gearbox
- New Bellhousing (or adaptor plate on 1500cc models)
- Spigot Bushing
- Clutch Plate
- Clutch Plate Cover
- Clutch Release Bearing
- New Clutch Arm Pivot
- New Propshaft
- Chassis Cross Member and Strengtheners
- Speedometer Cable
- Standard Gear Lever

- Gear Lever Gaiter
- All Bolts and Fasteners
- Detailed Instructions

*Note: Speedo will need to be recalibrated*

Sprite/Midget 948	440-145	\$5,350.00	🏆
Sprite/Midget 1098	440-155	5,185.00	🏆
Sprite/Midget 1275	440-165	5,185.00	🏆
Midget 1500 1975-77	440-175	4,995.00	🏆
Midget 1500 1978-on	440-177	4,995.00	🏆
Shift Knob - 7mm	041-546	\$36.99	
Clutch Alignment Tool	041-620	\$2.89	



## Oil Catch Can by Mishimoto

A running engine creates blow-by, which is an oil mist that is routed either back to your intake manifold or to the atmosphere under your engine. Not only does that make a mess of the underside of your sports car, it can also lead to carbon build-up in your combustion chamber which reduces performance. By installing an oil catch can between the engine and either your intake manifold or the atmosphere, you can trap all that oil and dispose of it properly. Much more information online.

Oil Catch Can - 16 oz. 223-075 \$139.99



## Midget 1500 Oil Cooler Installation Kit

This kit allows the fitment of a 13 row oil cooler (not included) on a 1500 Midget. Cooler oil means longer engine life.

1500 Oil Cooler Instl. Kit 235-922<sup>1</sup> \$179.99  
13 Row Oil Cooler 235-925 52.99

<sup>1</sup>May require relocation of air pump hose.



800-667-7872



## Shift Lever Anti-Rattle Kit

As a Sprite/Midget owner, you will at some point experience that irritating, rev-dependent, rattle resonating from your shift lever. Shift-rattle is the result of worn or missing anti-rattle components. Fortunately, with our complete anti-rattle kit, you can quickly put an end to this common annoyance. Our kit contains the plunger, bushing, both springs and the O-ring.

Sprite/Midget 1958-74 462-850 \$14.99



## Spin-On Oil Filter Adapters

Cleaner oil changes will result if you change your engine from the messy original canister filter to a modern spin-on filter. Each kit includes all necessary pieces for installation, filter not included.

Adapter (not 1500)	235-875	\$99.99
Spin-On Filter - Fram	235-880	7.99
Spin-On Filter - Wix	235-855	10.99
Spin-On Filter - K&N	235-830	18.99



## Alloy Flywheel by Fidanza

Fidanza Performance lightweight aluminum flywheels are designed, engineered and manufactured right here in the USA. These flywheels have been CAD designed/engineered and precision CNC machined from top quality billet 6061 T6 aluminum to deliver optimum performance and reliability. All flywheels are balanced and thoroughly inspected for quality and fitment.

Fidanza aluminum flywheels deliver:

- Faster throttle response and quicker acceleration
- Additional horsepower to the wheels (reduced parasitic losses)
- Smoother, faster shifting
- Easier braking, better slowing (due to reduced rotational mass)
- Reduced clutch wear and improved efficiency (from better heat dissipation)
- Replaceable friction plate

Sprite/Midget 948	460-505	\$459.99
Sprite/Midget 1275	461-005	459.99



## Upgraded 1275cc Clutch Disc

This upgraded clutch disc should be used for supercharged applications or if engine power is increased above 90 hp. This disc has stronger springs and center diaphragm and an improved lining material.

Upgraded Clutch Disc 190-891 \$289.99

## K&N Performance Oil Filter

For spin-on adapter kit. K&N filter technology is the leader for your spin-on oil filter conversion. Resin impregnated filter element traps even the tiniest contaminants and isn't affected by racing fuels. Featuring heavy-duty construction with metal endcaps, anti-drainback valve and a 1" safety wire drilled wrench nut; this is the best on the market.



K&N Oil Filter 235-830 \$18.99

\*See ordering page for details

WWW.MOSSMOTORS.COM



## Double Ended Fuel Pump

Double ended SU pumps have been standard equipment for years on Aston Martins, Bentley and late model E-Types. Delivering twice the capacity of a standard type pump, these units will keep on pumping even if one side fails. Well suited for all high performance engines running SU carbs, as no pressure regulator is required.

### Standard Points

Non Polarized 377-036 \$449.99

### Solid State

Negative Ground 377-335 \$489.99



## SU Solid State Fuel Pump

Solid State electric fuel pumps with modern, reliable electronics eliminate the use of contact breaker points. Now you can have a vintage looking SU fuel pump with peace of mind that only an electric fuel pump can offer. Plus the characteristic ticking is retained.

Positive Ground 377-295 \$167.99  
Negative Ground 377-285 167.99



## ECCO Plastic Body Fuel Pump

The ECCO electric fuel pump is a direct replacement for the SU pump. It is made from mostly plastic materials with the main coil housing assembly being made from Glass Reinforced Poly. There is a decades old, lingering misconception that the plastic will crack at the banjo. Rest assured, this is not the case with the modern pump. The ECCO pump is hand built, and the quality of the end product is heavily scrutinized during production. This pump will operate trouble free for years to come. Works on positive and negative ground vehicles.

1098 (10CC), 1275 377-176 \$139.99



## Facet Solid State Fuel Pump

Solid state electric fuel pumps can be used in conjunction with, or in place of your original pump. The solid state pump will push or pull fuel from a hidden location under the car, through your original pump, or put it in line with a power switch and use it as a backup. Works on positive or negative ground cars.

Solid State Fuel Pump 377-420 \$89.99  
Facet Filter 377-424 10.99



## Fuel Filter/Regulator

High quality universal fuel pressure regulator with integral filter comes with 1/4" and 3/16" fittings. Pressure adjustment is 3psi to 9 psi. Pre-set to 3-3.5 PSI for SU & ZS carbs. For carburetor equipped cars (not for fuel injection). Made in Italy.

Fuel Filter/Regulator 377-435 \$119.99  
Replacement Filter 377-436 13.79  
Replacement Bowl Gasket 377-437 6.39



# PERFORMANCE

FUEL A29



## Billet Fuel Filter Kit

The clean lines of this filter assembly will add a touch of custom brightness to the engine compartment. The filter is easily disassembled for cleaning. The chromed hose barbs can be removed and 3/16" AN-6 fittings attached directly to the body of the fuel filter giving a high degree of fitment flexibility.

Billet Fuel Filter 377-305 \$69.99  
Repl. O-Ring, 7/8" OD 772-815 2.19  
Repl. O-Ring, 1 1/4" OD 772-816 0.99



## Manual Choke Conversion Kit

Designed in England by Zenith-Stromberg. Includes all mounting hardware and detailed instructions. Easy installation.

Midget 1500 386-325' \$119.99

<sup>1</sup>May not be legal on emission controlled vehicles. Check your local laws for compliance.



## 1962-74 Oil Cooler Installation Kit

A-Series engines were never intended to operate at the speeds and temperatures we experience on American highways. Water may cool the cylinder head and block, but your oil needs cooling as well. Overheated oil leads to increased wear and shorter engine life. Low oil pressure could be a sign of a worn engine, but it also happens when the oil gets too hot. Our bespoke oil cooler fitting kit includes braided stainless lines, all hardware, instructions and correct factory fittings. Combined with our 13 row oil cooler, it's an affordable life insurance policy for your expensive motor.

Stainless Steel Hoses 235-878 \$189.99  
Rubber Hoses 235-879 159.99  
13 Row Oil Cooler 235-925 52.99



# PERFORMANCE

**A30** CARBURETORS

## Performance Intake Systems

One of the best ways to improve the performance from any engine is to make sure the gas enters the cylinder head as quickly and efficiently as possible. To ensure this we have selected the most respected and popular range of intake manifolds on the market today.

### High Flow Alloy Intake Manifold

High flow alloy intake for a single 1 1/4" carb, the larger ports make this manifold ideal for large capacity engines e.g. 1380 cc.

High Flow Alloy Intake Manifold 117-177 \$92.99

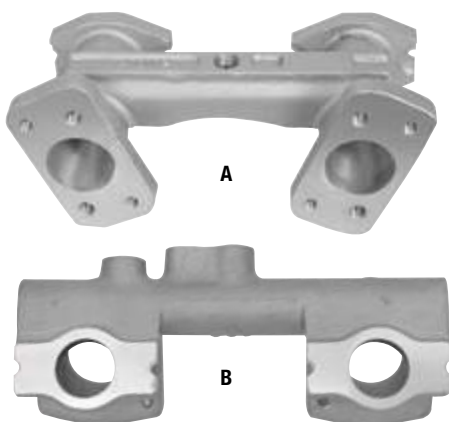

### Twin SU Alloy Intake Manifolds

These intake manifolds are for twin SUs. The manifold for larger HS4 or HS6 carbs is reproduced to the original Abingdon ST design.

(A) Twin SU Manifold for HS2/4 114-289 \$259.99  
 (B) Twin SU Manifold for HS4/6 114-286 169.99



### Racing SU Ram Pipe Sets

A racing tradition, now available in long (3") and short (1 1/4"). Set of two. Check with your salesperson if you are unsure which carburetor you have. For 1 1/4" carburetors. Sold as a pair.

Short 372-425 \$69.99  
 Long 372-405 69.99

### Ram Pipes for SU Carburetors



These fully radiused ram pipes improve air flow into the SU carburetor, ideal for use with or without filters (space permitting). The K&N ram stack is designed for its own filter assembly.

HS4 Ram Pipe - Silver 114-427 \$52.99  
 HS6 Ram Pipe - Silver 114-424 52.99  
 40 DC0E Ram Pipe - Silver 117-291 47.99

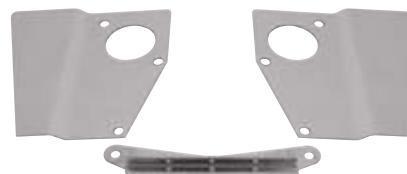

### Twin SU Stainless Steel Heat Shields

These new mirror finish stainless steel heat shields not only look great, they also redirect some of the heat from the exhaust manifold.

Twin SU S/S Shields HS4 117-180 \$29.69

### Dashpot Covers for SU Carburetors

Polished or anodized dashpot covers are an easy way to brighten the engine bay. Sold individually.

SU HS2 - Silver 117-167 \$22.99  
 SU HS4/6 - Chrome 374-575 19.99  
 SU HIF44/6 - Silver 114-473 29.99



### MG Crested Carburetor Caps

These very distinctive solid brass caps make any engine compartment unique! Your original damper rod must be reused and pressed into the new cap.



Dashpot Caps, pair 370-735 \$32.89

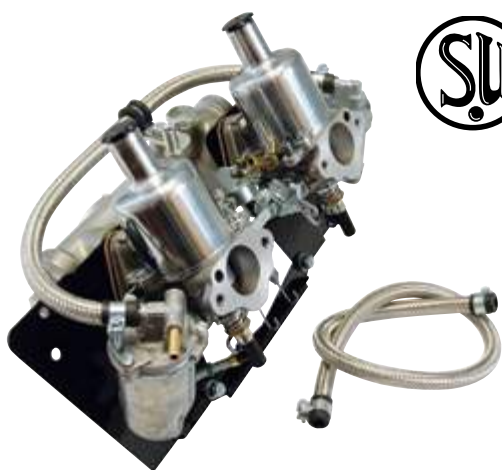

### SU HS4 Twin Carburetors

This kit is designed to allow more fuel and air into the engine, while keeping that distinctive period look of a pair of classic SU carburetors. For the best results these carbs require a sports exhaust system. The kit includes all the parts you'll need for installation: manifold, heat shields, carbs, linkages, etc. Air filters not included.

HS4 (1 1/2") Twin Carburetor Kit 114-494 \$1,575.00



### Knurled SU Idle Screw Kit

The Knurled SU Idle Screw allows you to fine tune your idle without having to reach for a screwdriver. Made specifically for the SU carburetor, this upgrade is quick and easy.

Knurled SU Idle Screw Kit 372-835 \$9.99

### SU H-Type 'Superdry' Jet Bearing Kit

The seals used until now have consisted of two small and one large cork seal. There is some evidence which suggests that ethanol may degrade these. A new set of rubber seals and the required new jet bearings have been developed to overcome this problem.



SU H-Type, sold individually 370-396 \$64.99  
 Superdry Seal Kit - Replacement 370-397 10.99



800-667-7872

\*See ordering page for details

WWW.MOSSMOTORS.COM



### Weber DCOE Conversion

High performance DCOE carburetors are still the enthusiast's choice to extract maximum power. The kit includes manifold, linkage and carburetor with ram pipes. Our Weber DCOE kits come pre-jetted for the listed applications. However, fine tuning will be necessary. We recommend that tuning be performed by an experienced tuner. Please note that there is no provision for emission connections and some modification will be required for best operation.

<b>Sprite/Midget 948/1098</b> Single 40DCOE	222-440 <sup>1</sup>	\$879.99	
<b>Sprite/Midget 1275</b> Single 45DCOE	222-450 <sup>1</sup>	879.99	
K&N Air Filter (1 3/4" deep)	222-245	104.99	
K&N Air Filter (3" deep)	222-240	91.99	
<b>Sprite/Midget 1500</b> Single 40DCOE	222-480 <sup>1</sup>	769.99	
<b>Accessories</b>			
Stainless Steel Heatshield	865-220	26.99	

<sup>1</sup>May not be legal on emission-controlled vehicles. Check your local laws for compliance.



### Weber DCOE Soft Mount Kit

Vibration plays havoc with fuel level, so any Weber DCOE installation works better when the carburetor is isolated from the manifold. This kit solves the problem and, following up on customer requests, we now have it in stock.

Weber Soft Mount Kit	222-251	\$32.99
----------------------	---------	---------



### K&N Air Filter for 1 1/4" SU

1 1/4" tall filter with offset mounting. Suitable for use on Sprite & Midget 948-1275cc (except Bugeye). Cleanable and reusable, K&N filters carry a 1 million mile warranty.

Filter, for 1 1/4" SU	223-010	\$134.99
-----------------------	---------	----------



### Weber Downdraft Carb Kits

The Weber DGV two barrel progressive carburetor has proven to be the most popular replacement for worn out or damaged stock carburetors and gives a good combination of performance and economy on stock engines. Our Weber DGV kits come pre-jetted for the listed applications. Kits include instructions, carburetor(s), manifold/adapters, linkage and air filter(s). Please note that there is no provision for emission connections and some modifications will be required for best operation.

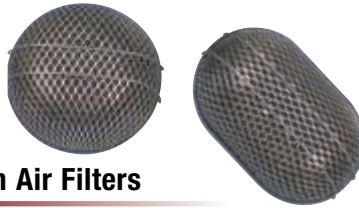

### Foam Air Filters

The traditional performance washable foam filters.

Round for 1 1/4" SU	223-260 <sup>1</sup>	\$42.99
Oval for Midget 1500	223-280 <sup>1</sup>	42.99

<sup>1</sup>May not be legal on emission controlled vehicles. Check your local laws for compliance.



### K&N Chrome Air Filters

K&N air filters are designed to be washed and reused for the life of your engine. Ten year K&N warranty or one million miles (non-comp. use). All sold individually.

<b>Flat Assembly for Zenith-Stromberg</b> 1 3/4" deep	222-925 <sup>1</sup>	\$122.99
--	----------------------	----------

<b>Assemblies for Weber DCOE</b> 1 3/4" deep	222-245 <sup>1</sup>	\$104.99
3" deep	222-240 <sup>1</sup>	91.99

<b>Assembly for Weber DGAV</b> 1 3/4" deep	222-366 <sup>1</sup>	\$122.99
---	----------------------	----------

<b>Elements for Stock Applications</b> Sprite/Midget HS2	373-435	\$61.99
---	---------	---------

<b>Accessories</b>		
Filter Cleaning Fluid	231-480	\$12.99
Filter Oil Bottle (250 mL)	231-490	7.79
Filter Recharging Kit	001-130	14.99

<sup>1</sup>May not be legal on emission controlled vehicles. Check your local laws for compliance.



Sprite/Midget 948-1275	222-275 <sup>1</sup>	\$529.99
Midget 1500 (Water Choke)	222-255 <sup>2</sup>	559.99
Midget 1500 (Electric Choke)	222-256 <sup>2</sup>	559.99
Midget 1500 (Manual Choke)	222-257 <sup>2</sup>	529.99
Chrome Filter Assembly	222-365	43.99
Repl. Element for 222-365	222-364	15.89
K&N Air Filter Assembly	222-366	122.99
Carb Rebuild Kit - w/ Power Valve	222-266	49.99

<sup>1</sup>Will not fit Bugeye Sprite with original exhaust manifold. May not be legal on emission controlled vehicles. Check your local laws for compliance.

<sup>2</sup>May not be legal on emission controlled vehicles. Check your local laws for compliance.



### New SU Carburetor Sets

Genuine SU carburetors produced in the UK from new and original tooling.

Sprite MkII, Midget MkI	370-708 <sup>1</sup>	\$944.99	
Sprite/Midget 1098, 1963-66	370-718	944.99	
Sprite/Midget 1275, 1967	370-728	944.99	
Sprite/Midget 1275, 1968-69	370-908	949.99	
Sprite/Midget 1275, 1969-71	370-928	949.99	
Sprite/Midget 1275, 1972-74	370-948	949.99	

<sup>1</sup>Special order.

### Vintage Style Chrome Air Filters

Ultra-thin design beautifully plated.

Filter for 1 1/4" SUs each	223-100	\$44.99
----------------------------	---------	---------



# PERFORMANCE

**A32** EXHAUST



## Stainless Steel Exhaust System by Falcon

Constructed entirely of top-quality stainless steel, ideal system for your car if you live where winter road conditions are harsh. Includes all pipes from the manifold flange back. Clamps, hangers and (when required) catalytic converters not included.

948 to 1098 10CG	452-000	\$269.99	OS
1098 10CC	452-010	229.99	OS
1275 (1967)	452-010	229.99	OS
1275 (1968-69)	452-015	246.99	OS
Midget 1500	452-030	449.99	OS



## Header and Manifold Blanket

This flexible heat shield clips into place on your manifold or headers and retains exhaust heat, reducing under hood temperatures. Designed for use on a V8 engine, this kit has enough material to cover most four cylinder manifolds with enough left over to protect the starter motor and bulkhead. Two sheets 20" x 24".

Header Manifold Blanket	337-445	\$146.99
-------------------------	---------	----------



## Monza Free Flow Mufflers

Mufflers that increase both horsepower and gas mileage by reducing exhaust gas back-pressure. Heavy gauge steel, black with chrome tipped ends. Front down pipe not included.

Sprite/Midget 1275	452-040	\$206.99
Midget 1500	452-050	359.99

## Headers by Pace Setter

These tubular exhaust headers are suitable for vintage racing or the sporting enthusiast. The three into one and four into one design gives the best top end power and the large collector can be routed to a custom big bore racing exhaust for track use, or hooked to the stock or sport exhaust using the included adapter. Some hand fitting and port matching may be required. Headers supplied with anti-corrosive protection paint, header should be trial fitted before final paint. The 1500cc header has no provisions for e.g.r. valve or catalytic converter, so it is not legal for use on emission controlled cars.

Sprite/Midget 1275	459-014	\$199.99
Midget 1500	459-017	199.99

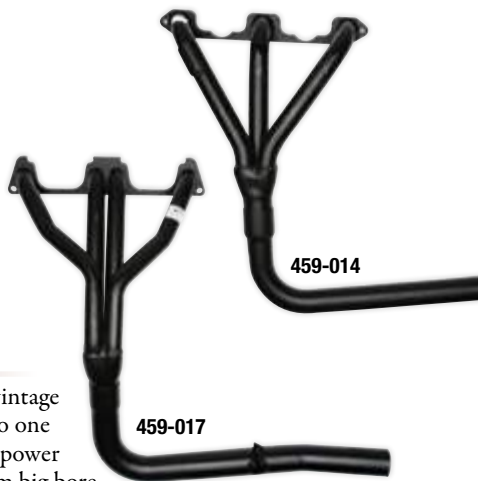

## Performance Exhaust Headers

These tubular exhaust headers are sourced from the UK and are designed to increase torque in street and vintage race motors. The smaller bore size, long center branch header is optimal for street use where a large bore race header would reduce low end torque making the car no fun to pull away from stop lights. Some hand fitting and port matching may be required. Headers supplied with anti-corrosive protection paint, header should be trial fitted before final paint. The 1500cc header has no provisions for e.g.r. valve or catalytic converter, so is not legal for use on emission controlled cars.

Sprite/Midget 948	452-060	\$379.99
Sprite/Midget 1098/1275	452-065	399.99
Midget 1500	452-070 <sup>1</sup>	399.99

<sup>1</sup>Does not fit with ZS manifold. For use with Carb. Conversions



800-667-7872

\*See ordering page for details

WWW.MOSSMOTORS.COM



**Stainless Steel Band Type Exhaust Clamps**



We now carry a full range of these band type stainless steel exhaust clamps.

1½"	412-025	\$4.39
1¾"	412-026	4.39
1¾"	412-027	5.39
1¾"	412-029	6.49
2"	412-030	6.49

**Stainless Steel U-Bolt Type Exhaust Clamps**



These Stainless Steel U-Bolt type exhaust clamps are strong, durable, and best of all, will not rust.

1½"	412-200	\$4.99
1¾"	412-201	5.49
1¾"	412-202	5.79
2"	412-203	5.99
2½"	412-204	6.29
2¾"	412-205	7.99



**Hayden Electric Fans**

Designed to be set up to run in either "pusher" (in front of the radiator) or "puller" configuration. The 10" fan requires a clear mounting area of at least 10¾" x 11½", while the 12" requires at least 11½" x 12½". The 14" requires at least 13¾" x 14¾". The preset temperature control will turn the fan on at 185°F and off at 170°F.

10" Electric Fan Kit	231-678	\$149.99
12" Electric Fan Kit	231-688	159.99
14" Electric Fan Kit	231-658	179.99

**Failsafe Thermostat**



Manufactured from high-grade stainless steel and copper, this thermostat locks open during overheating for added safety.

180° Thermostat	434-205	\$16.99
160° Thermostat	434-206	16.99

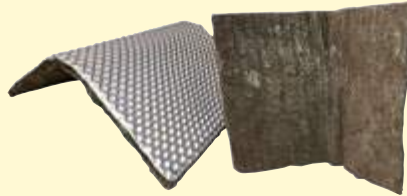

**Form-A-Shield by DEI**

Made from 10mil dimpled aluminum with a ¼" high temperature basalt insulation, Form-A-Shield can withstand direct temps to +1400°F. Form-A-Shield can be applied directly to hot surfaces and molds easily to exhaust manifolds, pipes and mufflers.

Form-A-Shield	231-905	\$91.99
---------------	---------	---------

**Positive Lock Tie Kit by DEI**

Stainless Steel Positive Locking Ties are designed for high heat applications. They are great for any application where a high strength tie is needed. UV and corrosion resistant they will last for many years under severe use. Perfect for securing exhaust wrap, cables, wires or hoses that are close to a heat source.



Positive Lock Tie Kit includes 8 - 9" Locking Ties (Up to 2" diameters), 4 - 14" Locking Ties (Up to 4" diameters) and Locking Tie Tool

**Features:**

- Made from 316 stainless steel
- Tensile Strength. ¾" 200 lbs. ½" 350 lbs.
- Capable of withstanding in excess of 2500 F

Positive Lock Tie Kit	231-910	\$28.99
-----------------------	---------	---------

**Thermostat Blanking Sleeve**



For maximum power and speed, such as racing conditions, it is advantageous to remove the thermostat, but only when this thermostat bypass blanking sleeve is fitted.

Blanking Sleeve	434-135	\$11.89
-----------------	---------	---------



**Muffler Shield Kit by DEI**

The best muffler shield/wrap on the market. Based off DEI's proven Floor and Tunnel II heat shield, this new Muffler Shield is designed to wrap around just about any size muffler. Includes tough Stainless Steel positive locking ties for a tight secure installation. Made from 10mil dimpled aluminum with a ½" needle glass insulator, it can be easily trimmed to fit most mufflers. Greatly reduces radiant heat coming off your muffler resulting in a cooler interior and protection from damaging heat.

Muffler Shield Kit	231-900	\$55.99
--------------------	---------	---------

**Stainless Steel Locking Tie by DEI**

Locking Ties are perfect for securing wrap to pipes with its self-locking design. Locking Ties offer many other uses including bundling wires, hoses, and other forms of insulation products. Just slide end into locking mechanism and pull tight.

**Features:**

- Constructed of high grade 304 stainless steel
- Capable of withstanding heat in excess of 2500°F
- Strong - 100 lb tensile strength

8"	231-911	\$1.89
14"	231-912	2.49
20"	231-913	2.69



**Remote Heater Valve Conversion Kit**

When the novelty of having to open the bonnet to turn on the heat in the cockpit wears thin or becomes a source of contention between spouses—it's time to look into a solution. A Remote Heater Valve connected with a cable and a control knob within reach of the driver does just the trick. Plus, it's a conversion you can easily do yourself. For 948, 1098 and 1275 engines only.

Conversion Kit	635-375	\$68.99
----------------	---------	---------

# PERFORMANCE

**A34** IGNITION & ELECTRICAL

## Flame Thrower Electronic Distributors by Pertronix

A modern electronic ignition unit already installed in a brand new distributor body that includes the drive dog. Two wire hookup to the coil makes wiring easy and the improved advance curve gives great performance and drivability. The vacuum advance is calibrated for use on carburetors that have ported vacuum, but in many cases will work well with manifold vacuum. The distributor is the 45D style.



**MORE INFO ONLINE**

4-Cylinder, Neg. Ground	143-116 <sup>1</sup>	\$254.99
4-Cylinder, Pos. Ground	143-125	259.99
4-Cyl. Repl. Cap	143-117	9.19
4-Cyl. Repl. Rotor	143-126	8.19
Repl. Module, Pos. Ground	143-127	112.99
Repl. Module, Neg. Ground	143-118	91.99

<sup>1</sup>Not for use with solid core ignition wires.

## Race Distributor

This points-type distributor has an advance curve designed for use with long duration race cams. Centrifugal advance only, for the serious racer.



45D Race Distributor	143-165 <sup>1</sup>	\$199.99
Replacement Points	153-915	2.99
Replacement Rotor	151-855	2.39
Premium Rotor	151-865	6.99
Replacement Cap	151-875	6.59

<sup>1</sup>May not be legal on emission controlled vehicles. Check your local laws for compliance.



## Dummy Voltage Regulators

A Dummy Voltage Regulator can be installed to retain original look after converting your vehicle to an alternator. They appear exactly as the old regulators, but have had their internals removed then bridged with a fuse. Extra fuse and instructions are included.

Screw Terminal	142-004	\$69.99
Lucar Spade Terminal	542-104	69.99
Late Style Spade Terminal	142-054	69.99



## Pertronix Ignitor Electronic Ignition

**PERTRONIX**

- No external control boxes to mount
- No points to set or change
- Hall effect sensor is impervious to dirt and moisture and retains stock advance curve
- Locate Lucas model number stamped in housing by the vacuum advance
- 30-month manufacturer's warranty

### Points Type

Negative Ground, DM2	222-605 <sup>1</sup>	\$135.99
Positive Ground, DM2	222-615 <sup>1</sup>	147.99
Negative Ground, 25D	222-405	112.99
Positive Ground, 25D	222-555	124.99

### 1500

w/Elec. Ign., 45DE4 & 45DM4	222-475	\$134.99
-----------------------------	---------	----------

<sup>1</sup>Not for use with solid core ignition wires.

## Pertronix Ignitor II for Mallory Dual Point Distributors

We now carry a Pertronix Ignitor system designed to retrofit Mallory dual point distributors. Offers the longevity of the Mallory distributor with the ease and accuracy of electronic ignition.

4-Cyl Negative Ground	143-181 <sup>1</sup>	\$169.99
4-Cyl Positive Ground	143-182 <sup>1</sup>	132.99

<sup>1</sup>Not for use with solid core ignition wires.



## Pertronix Ignition Coils

The Pertronix Ignition Coil isn't called the "Flame-Thrower" for nothing. Matched to the Pertronix Ignitor ignition and with a voltage of 40,000, this coil will deliver a smoother response and better fuel economy, along with enhanced power during acceleration. Ballasted ignition system was used from 1975 on.

Non-ballasted systems - Black	143-265	\$44.99
Non-ballasted systems - Chrome	143-266	49.99
Ballasted systems - Black	143-270	44.99
End Clip for solid core wire	571-037	0.79
Boot for push-in wire end	571-047	1.49



## XR700 Electronic Ignition

Replace your troublesome points and condenser with this easily installed kit. FAST (formerly Crane) electronic ignition systems are famous for their reliability. Expect faster starts, cleaner running and better performance at all engine speeds.

For Lucas Points-type Distributors	222-680	\$179.99
For Lucas Electronic Distributors	222-325	159.99

## Smiths Voltmeter

This 2" gauge can be easily wired into your car to give an indication of battery condition. Includes installation instructions and bulb holder with bulb for illumination.

Voltmeter	360-975	\$99.99
-----------	---------	---------

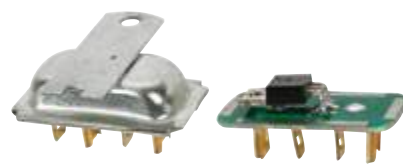

## Solid State Voltage Stabilizers

We have developed a replacement voltage stabilizer that combines modern electronics inside a vintage Smiths style housing. Instructions provided which include a gauge troubleshooting section.

Negative Ground	131-555	\$12.99
Positive Ground	131-556	16.99

## Premium Ignition Rotors

The carbon content in the plastic of most ignition rotors today is way too high and will actually rob your engine of precious spark energy. Don't let your ignition rotor ruin your Sunday drive; replace yours with one that is manufactured correctly.



948-1098-1275 25D	151-805	\$6.99
1500 45D	151-865	6.99

Hear about the latest news, first.  
**eNEWS**  
SIGN UP AT MOSSMOTORS.COM



800-667-7872

\*See ordering page for details

WWW.MOSSMOTORS.COM

## Sports Coils by Intermotor



Intermotor was the original manufacturer of the renowned Sports Coil. Extensive testing has proven the Intermotor Sports Coil to be exceedingly dependable. A 40,000 volt output provides reliable starting power, along with greater performance at higher RPM. Made in England.



*Note: These coils require a push-in type coil wire.*

Non-ballasted systems	143-201	\$42.99
Ballasted systems	117-264	42.99
End Clip for solid core wire	571-037	0.79
Boot for push-in wire end	571-047	1.49



## Bumblebee Ignition Wire

This type of distinctive competition wire was a very popular performance accessory with the BMC/BL Competitions Department from the 50s to the 70s. Sold per foot.

Bumblebee Wire	571-020	\$5.29
----------------	---------	--------

## Battery Tray Liner

Tough, corrosion-proof battery tray liner protects precious sheet metal. Fits through 1967.

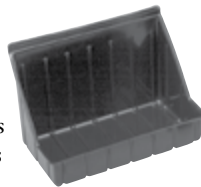

1958-67	241-020	\$49.99
---------	---------	---------



## Warning Labels

These warning labels can help protect your vehicle from people who aren't quite as familiar with these cars as you are. Capture their attention, before potentially expensive mistakes, with these traditionally styled, 4"x1", glossy decals.

Positive Earth	215-010	\$3.49
Silicone Brake Fluid	215-005	4.49

## Battery Acid Neutralizing Mat

Made from a special acid absorbent material which neutralizes acids as they leak from your battery. Easily cut with scissors to match the shape of any battery or tray.



Battery Mat	241-025	\$7.69
-------------	---------	--------

## Racing Battery Switch

Primarily intended for competition use, this rugged switch can be used on any car. The removable key deters theft. Attached rubber cap keeps dirt and water out when the key is removed. Meets FIA requirements for motor sports.



Racing Battery Switch	145-785	\$29.99
-----------------------	---------	---------

# PERFORMANCE

IGNITION & ELECTRICAL

A35



## High Performance Plug Wire Sets by Cobalt

These wire sets are made to our specifications using the highest quality materials. These require a #163-810 plug-in distributor cap be used on early cars in place of the side entry cap.

- 8mm Silicone Jacket resists high temperatures, fuel and oil
- Compact Silicone Boots with Locking Terminals
- Spiral Magnetic Core to suppress RFI/EMI Interference

948-1098-1275	171-662	\$39.99
Midget 1500	171-663	39.99
Distributor Cap	163-810	8.99



## MAGNECOR Performance Plug Wires

Magnecor competition spark plug cable sets work great on street cars with either conventional or electronic ignition systems. Low resistance, yet also shielded to reduce radio noise interference.

Midget 1500	143-556	\$109.99
-------------	---------	----------



## Battery Cut-Off Switches

Battery cut-off switches simplify servicing and long-term auto storage. A strategically placed remote switch deters theft. A negative post mount switch is quickly accessed.

Remote Switch - 1" shaft	145-770	\$49.99
Remote Switch - ½" shaft	145-771	49.99
Negative Post Mount	145-795	5.99



## Alternator Conversion Kit

Complete kit of all parts and instructions to convert from generator to alternator. Does not have provision for Bugeye tach drive.

A Dummy Voltage Regulator can be installed to retain original look. They appear exactly as the old regulators, but have had their internals removed then bridged with a 50amp fuse. Extra fuse and instructions are included.

Alternator Conversion Kit	130-068	\$259.99
Dummy Voltage Regulator - Screw Terminal	142-004	69.99
Dummy Voltage Regulator - Lucar Spade Terminal	542-104	69.99
Dummy Voltage Regulator - Late Style Spade Terminal	142-054	69.99

## Universal Coil Mounting Brackets

Replace missing, bent or corroded coil brackets. Also useful if you are upgrading or relocating the coil.

Chrome	143-255	\$11.29
Stainless Steel	117-265	13.99
Zinc Plated	143-256	4.99

# PERFORMANCE

**A36** BRAKES



## Front Disc Brake Kits

When your Sprite/Midget needs a brake job, ordering one part number and getting everything you need at once makes the job so much simpler.

There are two options available, Stock Replacement and Stage 1 Upgrade. See below for option details.

### All Kits Include:

- 2x pad retaining clips
- 2x pad cotter pins

### Stock Replacement:

- 2x Stock front rotors
- 1x Classic Gold semi-metallic front pad set

### Stage 1 Upgrade:

- 2x Slotted & drilled front rotors
- 1x Classic Gold ceramic front pad set

Stock Replacement - w/ Wire Wheels 182-161	\$54.99
Stock Replacement - w/ Disc Wheels 182-157	51.99
Stage 1 Upgrade - w/ Wire Wheels 182-695	159.99
Stage 1 Upgrade - w/ Disc Wheels 182-690	159.99

## Cross-Drilled & Slotted Brake Rotors

These cross-drilled & slotted rotors are a performance upgrade option for your Sprite/Midget. Under hard use the brake pad surface emits gasses which cause the pads to plane over the surface of the rotors. The grooves in these rotors channel the gasses away from the braking surface and reduce brake fade, while the cross-drilled holes assist with heat dispersion. The grooves also reduce pad material build-up on the rotor surface and minimize glazing. Sold in a left-hand/right-hand pair.

Disc Wheels	586-601	\$92.99
Wire Wheels	586-602	129.99



## Cross-Drilled & Slotted Rotors

Get the stopping power you need with a Moss Motors exclusive. Cross-drilled holes lower brake temperatures and reduce rotational mass and out-gassing, while slots allow excess water, dirt and dust to dissipate. Sold as a pair.

Disc Wheels Only	586-600	\$199.99
------------------	---------	----------



## CLASSIC GOLD<sup>®</sup> AUTHENTIC REPRODUCTION



## Premium Ceramic Brake Pads by Classic Gold

- Withstands High Braking Temps
- Less Fade
- Quicker Recovery
- Ultra Quiet Braking
- Nearly Dust Free
- Wheels Stay Cleaner Longer
- Anti-Squeal Compound bonded to brake pad backing plate

Ceramic Pad Set	071-533	\$35.99
-----------------	---------	---------

## Semi-Metallic Brake Pads by Classic Gold

- Shorter Stopping Distances
- Squeal Free
- Less Dusting than Organic Pads
- Asbestos Free Composition
- Best Value - Priced Right
- Anti-Squeal Compound bonded to brake pad backing plate

Semi-Metallic Set	071-539	\$21.69
-------------------	---------	---------

## High Performance Front Disc Brake Pads

### EBC Greenstuff Brake Pads

EBC Greenstuff is a high friction based pad compound designed to improve stopping power on sport cars for street use. The Greenstuff range emits less dust than equivalent semi metallic pads and has been proven in tests to stop a vehicle 20 feet sooner than using stock pads.

### Hawk Brake Pads

Designed for the serious street and autocross enthusiast these pads are at home on both the track and street.

*Note: due to the increased friction levels, brake rotor life may be decreased.*

Greenstuff	585-625	\$76.99
Hawk	585-605	109.99

Pads are fully shimmed, chamfered and slotted for silent braking and feature the EBC brake-in surface coating to accelerate pad bed in after install. Greenstuff pads are designed for spirited street driving. Made in the UK.



585-625



585-605



800-667-7872

\*See ordering page for details

WWW.MOSSMOTORS.COM



**Sprite/Midget  
Nitrided Rear Axle Shaft**

Since the weak link in any hot rod or Midget is the rear axle, this is a component that really needs all the increased strength it can get. Nitridization is a process that surface hardens the outside surface of the steel to approximately 70 HRC. This results in decreased wear and improved fatigue life.

Axle Shaft, Disc Wheels 265-302 \$359.99



**Brake Servo Kit-  
Single Line System**

If your single-line brakes are working as they should but you'd like the pedal to require less foot pressure, install this servo manufactured to the highest standards. Includes detailed instructions for proper fitment of the servo.

Single Line System Brake Servo 117-312 \$165.99



**Face Adjusted Wheel Bearing Kit**

Original size wheel bearings have completely disappeared from the marketplace, leading to the proliferation of inferior replacements that almost fit but cannot be adjusted to remove play in the mounted wheel. To solve this serious problem, these new wheel bearing kits are specially machined for your Sprite or Midget and can be installed with absolute confidence that they will work straight out of the box and provide the proper amount of endplay. Two required per vehicle.

Wheel Bearing Kit - Face Adjusted 125-825 \$119.99

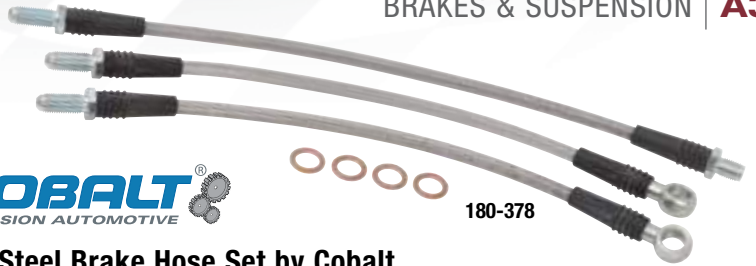

180-378

**Stainless Steel Brake Hose Set by Cobalt**

Stainless steel brake hoses provide a more direct and consistent brake feel. They won't expand like rubber hoses can. Order this complete set of long-lasting braided steel hoses for your next brake job. DOT approved.

Sprite-Midget (with front and rear drum brakes)	180-358	\$74.99
Sprite-Midget (with front disc brakes)	180-378	74.99



**GOODRIDGE**

**Braided Stainless Steel Teflon  
Brake Hose Sets by Goodridge**

These competition-inspired brake hose sets meet all DOT safety standards and are street legal in all 50 states. Each set includes all brake hoses used on your car, with any required retaining nuts and/or copper sealing washers.

With Front Drum Brakes	182-198	\$78.99
With Front Disc Brakes	182-248	78.99



125-822

**Tapered Front Wheel Bearing Kit**

The standard front hub bearings are angular contact ball bearing type, which works well but does not allow for any adjustment as the bearings wear. Our tapered bearings provide better support. Our tapered bearing kits includes high quality bearings, seals, spacer ring, split pin and nut and utilizes the standard spacer for a simple installation. The larger bearing has the correct 2mm fillet radius to allow proper fitment on the stub axle and has been specially manufactured to allow the hub to sit in the correct position so the caliper does not interfere with the disc.

We offer two types of tapered front wheel bearing kits. The first (125-822) is the complete car kit, which consists of all the bearings, seals, spacer rings, shims, split pin, nuts and grease required for both wheels. The other kit (125-821) consists of the bearings, seals, spacer ring, split pin, nut and grease for a single wheel only and does not include the shims.

Front Wheel Bearing Kit - complete car kit	125-822	\$69.99
Front Wheel Bearing Kit - 1 side	125-821	35.99
Wheel Bearing Shim Set	263-508	6.89



**Rear Disc Brake Kit by Frontline**

This kit delivers the ultimate braking for the rear of your Spridget! The kit uses 8" discs with alloy calipers to allow rapid heat dissipation and reduced fade under continued heavy use and eliminates wheel lock under heavy braking. The system has been designed to work in conjunction with any of Frontline's front brake conversions to give the optimum and most balanced braking set-up for your car.

1964-79 w/13" Wheels	586-647 <sup>1</sup>	\$2,299.00
1964-79 w/14" Wheels	586-648 <sup>1</sup>	1,999.00

<sup>1</sup>Kits are made to order. Please allow six to ten weeks for delivery.

# PERFORMANCE

## A38 SUSPENSION

### Frontline Tube Shock Conversion Kits

The Frontline suspension conversion has been developed in conjunction with specialist suspension engineers to give what is probably the single biggest improvement to the Sprite/Midget's handling. The specially developed telescopic dampers provide progressive damping - as suspension movement increases, the shock absorbers increase resistance - which lever shocks are not able to do.

To maintain front and rear continuity, adjustable AVO shocks are used allowing you to adjust the ride to your personal requirements and driving style.

#### Front Conversion Kit

1958-80	268-168	\$1,295.00
Replacement Shocks - Pair	268-169	549.99

#### Rear Conversion Kits

1958-63	268-171 <sup>1</sup>	\$599.99
1964-74	268-172	599.99
1975-80	268-173	599.99
Replacement Shocks - Pair	268-174	449.99

<sup>1</sup>Requires some welding.



**EXCLUSIVE**



### Moss Rear Tube Shock Conversion Kit

Modern tube shocks provide better ride comfort and handling than the old lever arm style. When was the last time you checked your rear shock fluid? Most people don't, and this leads to premature wear and leaks, which render the shocks worthless. The Moss R&D shop has come up with a specially modified set of rear tube shocks which, along with a few simple mounting bolts, gives your car a better, maintenance free ride. Can be installed on Midget 1500; sheet metal shrouding upper mounting must be trimmed.

1964-74 Rear Conversion Kit	268-288	\$299.99
-----------------------------	---------	----------

### Rear Tube Shock Conversion Kits

These kits contain the Spax adjustable gas filled shocks (adjustable from the outside). Includes new lower spring plates that incorporate an angled mounting flange. Installation is easy and instructions are included.

1964-74	264-675	\$499.99
1975-80	264-676	489.99



### 3/4" Anti Sway Bar

The 3/4" anti sway bar is an excellent compromise for both fast road, and competition use. Increased front sway bar diameter reduces body roll and understeer which in turn gives better handling control.

3/4" Anti Sway Bar, front	264-555	\$189.99
Solid Sway Bar Mounts (Pair)	263-435	79.99
Rubber Mounting Bushing (Individual)	280-915	2.19
Polyurethane Mounting Bushing (Pair)	683-062	19.99
Mounting Strap (Individual)	263-430	0.89

**NEW**



### Superpro Polyurethane Bushings

An Australian-based company, SuperPro began manufacturing replacement bushings made from polyurethane after they realized that OE rubber couldn't withstand the tough and extreme conditions found in the notorious outback. Rubber has been a traditional material for comfort, but is prone to vulnerabilities and deterioration. Polyurethane bushings ensure the suspension components will retain their desired geometry and last longer than rubber. SuperPro has tuned their bushings to work together on each car as a set. Each location may be stiffer or softer than another location on the same car. This ensures the car as a whole has the absolute best handling possible.

#### Complete Car Suspension Kit

1964-on	683-137	\$179.99
---------	---------	----------

#### Front Suspension

Complete Kit - 1964-on	683-135	\$89.99
Upper Trunion Bushing Set	683-040	19.99

#### Rear Suspension

Complete Kit - 1964-on	683-136	\$89.99
------------------------	---------	---------

#### Sway Bar Center Mount Kits

5/8" w/ original strap	683-060	\$19.99
5/8" w/ original strap	683-027	23.99
3/4" w/ original strap	683-062	19.99

### Heavy Duty Front Shock Valve

The higher spring pressure used in this valve is suited for use with heavy duty springs and larger than stock sway bars. Sold each, two required per vehicle.



Heavy Duty Valve	264-027	\$32.99
------------------	---------	---------



800-667-7872

\*See ordering page for details

WWW.MOSSMOTORS.COM



## Roll Bar

Our bolt-in roll bar looks great and causes minimum restriction of cockpit space. They're even designed to fit inside the convertible top. The optional pad is vinyl covered and uses snaps and velcro fasteners to keep it firmly in place. Includes mounting hardware.

1961-69 Roll Bar	453-325	\$679.99	
1970-79 Roll Bar	453-326	\$679.99	
Roll Bar Cover	236-000	98.99	

## Camber Adjusting A-Arm Bushing Sets



Offset nylon bushings allow for fine tuning of camber. Set of 4. Two sets required.

Camber Adj. Bushings	282-308	\$29.99
----------------------	---------	---------



## Front Suspension Lowering Kit

This kit contains special spacers which install between the wishbone/spring pan and the spring seat to lower your front suspension 1/2". Works with all springs. Kit includes spacers and bolts for both sides.

Front Susp. Lowering Kit	264-665	\$21.99
--------------------------	---------	---------



## Nylon Axle Straps

These rugged axle straps were engineered to last and are a substantial upgrade over the rubber straps currently on the market. Made from a nylon webbing, they offer some stretch properties, yet provide a tensile strength of over 4500 lbs. Sold in pairs. Metal tubes/sleeves should be reused on vehicles that originally required them.

Sprite/Midget 1958-74	267-611	\$34.99
Midget 1500	267-616	34.99



## Steering Rack

If you're tired of your Midget wandering across the road, install a new, factory-fresh rack and stop those wandering ways. Give your Midget the crisp steering you crave, our rack bolts right in for that new steering feel all over again. Don't forget Moss has all of the bushings, trunnions and hardware you need for a front end refresh.

Midget mid-1973-on	668-000	\$219.99
--------------------	---------	----------



## Prothane Bushings

Superb engineering design details differentiate these from other polyurethane replacement bushings. Grooved bores in some bushings to hold a special Teflon grease (included) make these bushing sets long-lasting and quiet.

Front Suspension Kit includes 4 upper and 8 lower bushings	280-938	\$48.99
3/8" Sway Bar Mount Kit	280-935	14.99
Rear Spring Kit (1/2 elliptic spring cars only)	266-418	84.99

## Nylatron Upper Trunnion Bushings

Nylatron bushings firmly locate your front suspension. Standard camber trunnion bushings are a direct replacement for your original bushings. The negative camber bushings are designed primarily for competition purposes and give improved steering and braking control. Sold individually, 4 required per car.

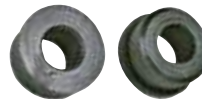

Standard Camber Bushing	264-585	\$24.99
Negative Camber Bushing	264-595	24.99



## Lowered Rear Springs

Significant gains in cornering ability can be achieved with lowered rear springs. Sold each.

1964-74 1" Lower	264-685	\$199.99
1964-74 2" Lower	264-705	209.99



265-591

## Front Spring Set by Suplex

We're asked what the big deal is with "those pricey Suplex springs." Here's the deal: They're that good. Simply put, they are made from pricey material that make them lighter, smaller and more durable than conventional springs. One of the great advantages of a smaller diameter spring is that it can compress further—in some applications giving you an inch more suspension travel. Five-year warranty. Chrome bumper only.

	Rate lb./in.	Ride Height	Part #	Price
<b>Standard</b> 1958-64, pair	300	9.5"	265-591	\$154.99
<b>Upated</b> Fast Road, pair	340	8.5"	264-606	154.99
Race, pair	400	8"	264-616	154.99



## Rear Spring Lowering Kit 1964-80

Easy to install kit lowers the rear of the car by 1/4".

Rear Spring Lowering Kit	268-170	\$91.99
--------------------------	---------	---------



# ACCESSORIES

A40 BOOKS



A.

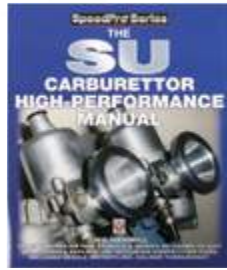

B.

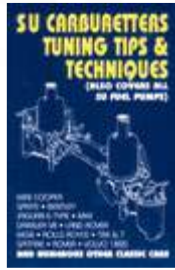

C.

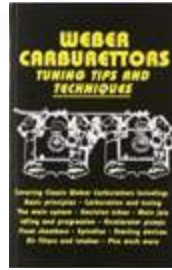

D.

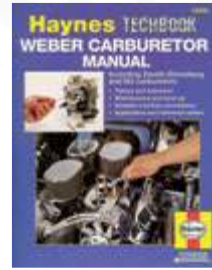

E.



F.

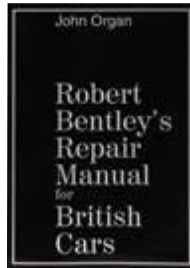

G.



H.

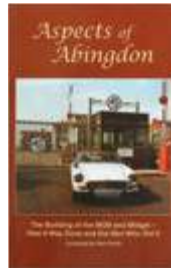

I.

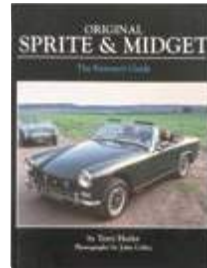

J.

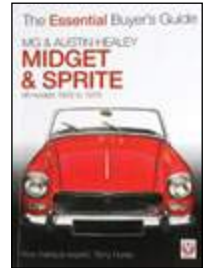

K.

## A. SU Workshop Manual

Factory workshop manual for SU carburetors and fuel pumps.

SU Workshop Manual 211-305 \$29.99

## B. SU High Performance Manual

Who wouldn't benefit from knowing the secrets that SUs hold? If you are looking to increase your SU repertoire, this is the book for you. Lots of pictures and illustrations. 96 pages.

SU High Performance 211-466 \$34.99

## C. SU Tuning Tips & Techniques by G.R. Wade

Factory information to help you solve all standard SU problems.

SU Tips and Techniques 211-345 \$28.99

## D. Weber Carburetors: Tuning Tips & Techniques

A distillation of many years' experience of working with Weber carbs. Setting the carburetor to suit a particular engine, fault-finding and the maintenance and repair of older carburetors are all topics which receive detailed attention. 128 pages, 200 b&w illustrations.

Weber Carbs, Tuning 213-431 \$27.99

## E. Haynes Carburetor Manuals

An excellent guide to tune up and maintenance of SU, Zenith-Stromberg and Weber carbs.

Carburetor Manual 211-430 \$29.99

## F. Lucas Fault Diagnosis

For professional technicians; easily understood by the non-professional. Softbound, 8½" x 11", 46 pages.

Lucas Fault Diagnosis 990-035 \$7.99

## G. Robert Bentley's Repair Manual for British Cars

Written in 1970, this book is a wealth of fault-finding and repair references for the British car owner. Covering a wide range of cars from Minis to Cortinas and all the sports car range, this book explains how the cars work and how to repair them. Softcover, 7" x 9". 380 pages, 225 b&w photos, 152 illustrations and diagrams.

Bentley Repair Manual 213-785 \$52.99

## H. How to Restore Automotive Interiors

A major part of any auto restoration is bringing the interior back to life. With nearly 200 pages and 500 color photos, this step-by-step guide walks you through restoring seats, door panels, floor coverings and headliners, as well as adding sound dampening and thermal insulation.

Interior Restoration Guide 213-865 \$29.99

## I. Aspects of Abingdon by Ken Smith

This is the 2nd edition reprint of a tribute to the workers who built the MGBs, MGCs and Midgets at the MG factory in Abingdon-on-Thames. With updated text, revised chapters and new photos. Learn how the cars were assembled and the changes needed to meet Federal safety and smog requirements.

Aspects of Abingdon 213-025 \$21.79

## J. Original Sprite/Midget Restoration Guide

This looks like a coffee table book and reads like one too - but its easily accessible information is nothing less than what you want. Loaded with original specifications, color schemes and factory options and dates. This book may be written for easy reading and may be readable by anyone - but the serious (or 'soon-to-be serious') enthusiast will recognize how valuable this information is.

Original Sprite/Midget Restoration Guide 211-406 \$49.99

## K. Sprite/Midget Essential Buyer's Guide by Terry Horler

This book is the perfect companion for the first-time or even more experienced buyer. All the information is here to help make a clear and balanced decision, to counter the vendor's claims, and even negotiate a better price. The author has bought and sold many MG Midgets & A-H Sprites over the years, and his knowledge and enthusiasm will prove a vital resource for potential buyers. 5.5" x 7.5", 64 pages, 100 color photos.

Sprite/Midget Essential Buyer's Guide 213-671 \$19.99

## L. Bentley Shop Manual

Robert Bentley manuals contain reprints of the factory workshop manual, plus the owner's manual. The most complete and authoritative manual available.

948-1098 212-330 \$79.99  
1275 212-340 79.99



800-667-7872

\*See ordering page for details

WWW.MOSSMOTORS.COM





L.



M.



N.

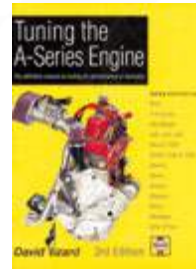

O.



P.



Q.



R.



S.

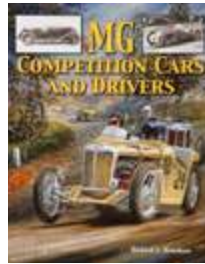

T.

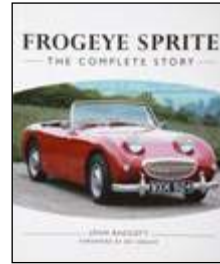

U.

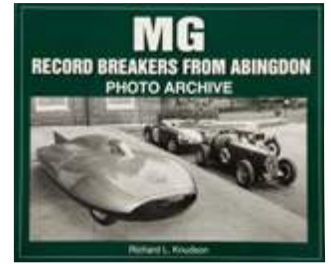

V.

### M. Restoring Sprites & Midgets

Written with technical expertise and wit, this manual is packed with photos and illustrations covering all aspects of restoration.

Restoring Sprites & Midgets 213-305 \$49.99

### N. Haynes Workshop Manual

A Haynes workshop manual is an excellent guide to the tune up and maintenance of your car.

Sprite-Midget 212-380 \$29.99

### O. Tuning A-Series Engines by David Vizard

This is the Bible for anyone wanting to improve their A-Series engine, be it for performance or economy. Covering every area of the engine, from crank to valve guides, with examples of modifications. 488 pages.

Tuning A-Series Engines 212-160 \$51.99

### P. Factory Workshop Manual Reprints

Everything from basic tuning data, to torque settings and complete component rebuilding.

Bugeye Sprite 212-465 \$59.89  
 Sprite MkII on/Midget to 74 212-475 64.89  
 Midget 1500 212-415 69.99

### Q. Glovebox Workshop Manual

This manual is packed with information. Tune-up data, repair and rebuilding information, dimensions and torque specs are in these compact 5½" x 8½" book. For all 1958-80.

Workshop Manual 212-480 \$34.99

### R. Your Expert Guide to Common Problems & How to Fix Them

Learn to identify all the things you need to be aware of to avoid mechanical trouble with your Spridget. This book walks you through the main components of your car and identifies potential problem areas to help keep you from being stranded or facing a major repair bill.

Buyers Guide 213-855 \$24.99

### S. Owner's Manual Reprints

Reprints of the manuals originally supplied with your car. From basic tuning and maintenance to putting up the top. An essential book for your library.

Bugeye Sprite 212-690 \$19.89  
 Midget MkII 212-705 22.99  
 Midget 1975-78 213-310 22.99  
 Midget 1979-80 213-320 21.99

### T. MG Competition Cars and Drivers

MG established its winning reputation through competition. This epic story by Knudsen, documents every competition car in extreme and careful detail, starting with Old Number One and finishing with MG record cars. Includes time-period photographs, many never published before.

MG Competition Cars and Drivers 210-240 \$34.99

### U. Frogeye Sprite: The Complete Story

Frogeye Sprite - The Complete Story covers the full story of the design, development and manufacture of the Mark 1 Austin Healey Sprite, including the considerable success of the car in racing and rallying. The title covers topics such as racing success and drivers, model variations, new builds and restoration, owners experiences as well as information and support for new owners.

Frogeye Sprite: The Complete Story 210-235 \$54.99

### V. MG Record Breakers from Abingdon Photo Archive

MG established its reputation as a world-class sports car manufacturer by winning races and breaking class speed records. This is the first book to provide in-depth coverage on these record-breaking cars. Including International Class Record Summary charts for the EX 120, EX 127, EX135, EX 179, and EX181 as well as driver summaries.

MG Record Breakers from Abingdon 210-245 \$29.99



### SU Carb Rebuild DVD

Tune or rebuild SU carbs with this easy-to-follow 2 hour 40 minute video.

SU Rebuild DVD 211-036 \$52.99



# ACCESSORIES

**A42** BOOKS & TOOLS

## Rule Britannia

When British Sports Cars Saved a Nation, celebrates this compelling story with authoritative text from John Nikas and his team of dedicated researchers and contributors; historic imagery from archives maintained by marque clubs, manufacturers, and museums; and modern portraits artfully captured in a studio setting by Michael Furman, the world's most renowned automotive photographer. 300 pgs; Hard Bound; Color Images, 10"x12".



**NEW**

Rule Britannia 215-105 \$89.00

## BMC Competitions Department Secrets

The inside story of a legendary works, Competition Department is told by the three competition managers of the highly successful BMC/British Leyland race and rally teams based at Abingdon. This book reveals the inner workings of one of the most successful motorsport teams Britain has ever seen. Based on previously unpublished internal factory memos, other documents, and the recollections of the prime movers, it describes the ups and downs and the politics of big-time competition. An excellent and entertaining read, no motorsport enthusiast should be without this book. 192 pgs; Soft Bound; 8"x10".



**NEW**

BMC Competitions Department Secrets 210-250 \$39.99

## Mechanical Ignition Handbook

Mechanically timed ignition is easy to understand and wonderfully straightforward to diagnose and repair, which is good because it's one of the most likely things on an older car to die and leave you in the lurch.

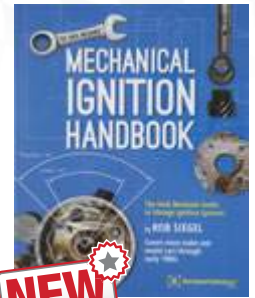

**NEW**

Author Rob Siegel explains how mechanical ignition works and discusses in detail how to set timing and advance. There is also a full chapter on troubleshooting mechanical ignition problems. Illustrated with over 100 photos and diagrams and supported by clear, step-by-step instructions, the Mechanical Ignition Handbook features sections on: Mechanical ignition basics and components, common repairs and recommended tools, adjusting point gap, finding top dead center, using both a standard and an advance timing light and much more. 150 pgs; Soft Bound; Color Images; 8"x10".

Mechanical Ignition Handbook 215-110 \$22.99

## SU Maintenance Tool Sets



### SU Jet Wrench

Mixture adjustments on SU H and HS carburetors are much easier with the proper tool. 5/16" W (.600" nut) fits original carbs. 17 mm (.669" nut) fits new upgraded carbs.

(A) 5/16" W Wrench 386-400 \$2.29  
(B) 17 mm Wrench 386-401 5.99



### SU Tool Kit

An assortment of handy tools for the home mechanic. Instructions included. Suitable for all cars with SU carbs. Includes jet wrench #386-400.

SU Tool Kit 386-300 \$21.99

### SU Jet Centering Tool

Jet centering is critical on older fixed needle SU carbs. This simple tool makes it a snap.

Centering Tool 386-500 \$34.99

## Bezel Remover Tool Set

The round bezels on most Lucas Switches have two slots, and nobody has the special tool you need to take them off. Using a screwdriver results in a scratched dash and colorful language. These tools have two teeth for the slots in the bezels and are made from hard steel so the teeth will last; critical for this application so you don't mar your bezels. The set includes tools for 3/4" diameter and 1" diameter bezel nuts.



1958-67 Toggle & Ignition Switches 384-960 \$29.99

## King Pin Reamer Tool

If you want to install new king pin bushings, they must be carefully reamed in perfect alignment after installation. This tool will help assure that your suspension is done right.

948 (Drum Brakes) 021-600 \$999.99  
1098, 1275, 1500 (Disc Brakes) 386-380 359.99



## Lift-the-Dot Hand Punch

Aimed at professional installers, this tool would make a fine car club tool box addition. Punches center hole and prong holes for installation of Lift-the-Dot fasteners to make installation of tops and tonneau covers a cinch.

Lift-the-Dot Hand Punch 226-105 \$74.99

## Sprite/Midget Rear Axle Hub Nut Wrench

This wrench fits the unique axle nut found on the Sprite and Midget. A standard 1/2" drive socket wrench can then be used to remove and reinstall the nut.

Sprite & Midget 384-959 \$53.99



## Clutch Alignment Tool

Accurately aligns your clutch disc for easy engine/transmission assembly.

948-1275 387-320 \$2.89  
1500 387-330 2.89



## Steering Wheel Nut Socket

An absolute necessity for removing steering wheel retaining nuts. A worthwhile investment - 2-sided, 15/16" and 1 1/2".

Wheel Nut Socket 384-906 \$32.99



## Grease Gun

For all those maintenance tasks.

Grease Gun 386-710 \$34.99



800-667-7872

\*See ordering page for details

WWW.MOSSMOTORS.COM



**Ignition Wrench Set**

High quality ignition wrench set by King Dick. Sizes 0 to 10 BA will handle most fasteners smaller than 1/4" on the car.

Wrench Set 385-000 \$66.99



**Phillips/Pozidriv All-In-One Screw Driver Set by King Dick**

Our revolutionary all-in-one screwdriver set features a patented tip design optimized for both Phillips head and Pozidriv patterns. All four screwdrivers are made from hardened and plated high-grade steel, and have soft-feel grips for comfort and control. Take the guesswork out of your British car tasks and save yourself the frustration of stripped screw heads. Works with PH1-2-3 & PZ1-2-3.

Phillips/Pozidriv 384-850 \$58.99



**7-Piece Ratcheting Combination Wrench Set**

Make quick work of tough jobs with this professional quality ratcheting combination wrench set. Made in England these wrenches have all the quality, performance and reliability you've come to expect from King Dick Tools.

**Whitworth Sizes:**

1/8"w, 3/16"w, 1/4"w, 5/16"w, 3/8"w, 7/16"w, 1/2"w

7-Piece Ratcheting Wrench Set 383-308 \$279.99



**8-piece Wrench Sets**

These quality Whitworth and Standard wrench sets were manufactured from a satin finished chrome vanadium, and feature a traditional oiled leather tool roll.

**Whitworth Set sizes:**

1/8"w, 3/16"w, 1/4"w, 5/16"w, 3/8"w, 7/16"w, 1/2"w, 9/16"w

**Standard Set Sizes:**

1/4", 5/16", 3/8", 7/16", 1/2", 9/16", 11/16", 3/4"

Whitworth Wrench Set 384-800 \$86.99  
Standard Wrench Set 384-805 \$6.99



**Drum Brake Adjusting Wrench**

Get a better grip on brake adjusters with our specially designed wrench. It has 1/4" and 3/16" square box end, and a long handle for improved leverage.

Adjusting Wrench 386-160 \$9.89



**No-Mar Tool Set**

Using the right tool for the job is a must if you don't want broken parts or scratched paint. This set of 5 pieces is perfect when you're removing fasteners, trim or molding and don't want to damage your paint or those expensive fasteners. No-Mar means the tools won't hurt your car or the parts you're removing. The small price is great insurance, and every tool box is incomplete without this set.

No-Mar Tool Set 231-830 \$23.99



**Tube Bender**

Bend fuel and brake lines exactly where you need them to go. This Tube Bender works great for brass, copper, steel and aluminum tubes of the following diameter: 3/16", 1/4", 5/16" and 3/8".

Tube Bender 385-905 \$20.99



**Ball Joint Puller & Separator**

These heavy-duty forged tools are the easiest way to split ball and taper joints, such as track rod ends from steering arms.

Puller 386-025 \$36.99  
Separator, Scissors Type 386-026 \$9.99



**Snap Installation Tool**

Install button snaps without damage.

Snap Tool 386-980 \$5.79



**Clikadjust Valve Adjuster**

Adjusting tappets is never a pleasant chore. This British tool takes much of the effort out of this necessary job. Turn the handle, click and tighten. Your clearance is set! Replaces the clumsy screwdriver/wrench combination with a single easy to use tool. Requires a 1/2" drive socket to fit tappet adjustment nut.

Clikadjust 386-205 \$109.99

# ACCESSORIES

## A44 GARAGE & TOOLS

### Brake Piston Resetting Tool

The right tool for the job makes life much easier. The Brake Piston Resetting Tool allows easier installation of brake caliper pistons, seals, and seal retainers.

Brake Piston Resetting Tool 386-285 \$41.99



### Scissor Type Ball Joint Separator

This scissor type ball joint separator has a 19mm jaw capacity and has a chemically blackened forged steel body with thrust bolt.

Scissor Type Ball Joint Separator 386-027 \$25.99



### Circlip Installation Tool

The wheel cylinder circlip is notoriously difficult to install. This easy-to-use tool changes all of that. You can now change wheel cylinders in a snap, while avoiding damage to parts or yourself.

Circlip Installation Tool 386-185 \$33.49



### Cooling System Air Purge Tool

Ensuring all the air is purged out of the later cooling systems can be tricky without this handy tool. Tool threads into the filler plug hole and allows easy topping off of the cooling system to ensure all air is evacuated.

1275-1500 384-965 \$53.99



### Carburetor Synchronizer

Used to synchronize airflow between multiple carbs, this is an indispensable tool for the serious home mechanic.

Carb Synchronizer 386-200 \$28.99



### Mityvac

This popular vacuum/pressure pump is perfect for bleeding hydraulic systems. Includes: vacuum/pressure pump, vacuum gauge, 1/4" tubing, automotive and brake bleeding adapter packages, reservoir jar and manual. Detailed instructions and ideas for additional uses.

Mityvac 386-215 \$79.99



### Professional Air Powered Bleeder

Air powered hydraulic bleeder uses siphon to bleed hydraulic systems. Hook the unit to air source, set air pressure to desired power, open the bleed screw and squeeze the handle.

Air Power Bleeder 386-225 \$229.99



### Carburetor Air Flow Meter

An Airflow Meter allows you to quickly tune your engine's carburetion. These precision instruments are designed to measure the airflow directly on the air intake of the carburetor and can be used at low and high RPM on down draft and side draft engines. The sensitivity and accuracy of the Airflow Meter is much greater than any other type of synchro tool or gauge. And the range of indication is very broad on the lower end of the scale to ensure precise adjustment at idle RPM. While a single instrument is sufficient, the use of one per carburetor is advantageous. The airflow of each carburetor can be constantly observed until the tune-up is completed. Made in Germany the BK Model is supplied with an adapter that is ideal for all ram pipes and intake bores of 1 1/4" to 2 1/4" (32 to 55mm Diameter) and provides an easy-to-read indication from 1 to 30 kg/h.

Carburetor Air Flow Meter 375-324 \$84.99

### Eezibleed Kit

Kit includes a pressure vessel and caps to fit 1958-67 master cylinders. Instructions included.

Eezibleed Kit 386-860 \$59.99



### Vizibleed Bleeder

Place the hose over a bleeder screw, put the check valve in an empty container, open the bleed screw and pump the pedal until clean, air-bubble-free fluid flows through the hose.

Vizibleed 386-885 \$11.99

### Gunson's Colortune

A glass topped spark plug allows you to see the color of combustion in your cylinders. Comes with special glass topped spark plug, viewing system for difficult plug locations and tuning procedure complete with troubleshooting guide.

Gunson's Colortune 386-210 \$84.99



### Kleenguard Disposable Coveralls

Remove some of the pain of roadside repairs with these disposable, convenient coveralls. Liquid and particle protection means you won't get grease on your clothes, and when your repairs are done, you can just throw the coveralls away and keep on motoring. Keep a spare in the trunk and you'll be covered.

Disposable Coveralls 219-481 \$14.99



800-667-7872

\*See ordering page for details

WWW.MOSSMOTORS.COM



## Tire Flat Spot Protectors

Flat Spot Protectors are essential for any owner looking to protect the lifespan and performance of their tires. Designed to increase the tire contact area and spread vehicle load, flat spot protectors minimize stress exerted on the tire, preventing sidewall cracks and flat spots forming during storage; offering additional benefits their ramped design also means that flat spots protectors function as effective vehicle chocks, avoiding the need to apply the handbrake (which can lead to binding of the rear brakes) and can also be secured to the floor to provide a garage parking stop function. Suitable for vehicles up to 8800lbs with 10"-18"x 7" wide wheels. Our Flat Spot Protectors benefit from a durable, high visibility, interlocking design and are supplied in pairs.

Tire Flat Spot Protectors - Pair 221-600 \$24.99



## Engine Roll Around Stand

If you have a spare engine to store, this stand makes it easy to move and keeps it off the ground. Dismantled, the engine stand stores easily until next needed.

Fits 948-1275 384-925 \$134.99



## Oberg Tilt Lift

Allows easy adjustment of an engine's lift angle through a full 90° of movement. Adjust with ½" ratchet; 2,000 pound capacity with a 3:1 safety load factor. A positive lock ensures the engine stays put. All steel construction and small size.

Oberg Tilt Lift 386-730 \$99.99



## Wire Harness Repair Kit

Our Wiring Harness Repair Kit makes fast, secure wiring connections a snap. Just crimp a bullet to each wire end using the included Bullet Crimping Tool. Push bullet ends into the connector sleeve. Snap firmly into place with the Closing Tool for a permanent repair.

The high quality, Bullet Crimping Tool ratchets closed to put a secure hexagonal crimp in bullets. The Closing Tool presses bullets firmly into both single and two-wire connectors.

### 161-751 Repair Kit with Tools Includes:

- Bullet Crimping Tool
- Closing Tool
- 30 each 18GA, 16GA, 14GA Crimp Bullets
- 10 Single-sleeve Connectors
- 6 Double-sleeve Connectors

### 161-752 Repair Kit without Tools Includes:

- 30 each 18GA, 16GA, 14GA Crimp Bullets
- 10 Single-sleeve Connectors
- 6 Double-sleeve Connectors

Repair Kit with Tools	161-751	\$199.99
Repair Kit No Tools	161-752	38.99
Crimp Bullets - 18GA Wire (10 Pack)	161-771	5.99
Crimp Bullets - 16GA Wire (10 Pack)	161-772	5.99
Crimp Bullets - 14GA Wire (10 Pack)	161-773	5.99
Bullet Crimp Tool	161-759	129.99
Closing Tool	161-761	39.99



## Auto Dolly

Wide heavy duty rollers and 6000 lb. capacity makes maneuvering your car easy.

Set of 4 Dollies 900-163 \$189.99

# ACCESSORIES

GARAGE & TOOLS

A45

## Chrome Halon Fire Extinguisher

Every classic car should have an affordable onboard insurance policy in the form of a functional fire extinguisher. Carrying one is just common sense. Halon is an extremely effective fire suppressant and causes the least amount of residual damage and is safe for human exposure. Our compact 10" chrome extinguisher can be easily mounted to many surfaces with the included bracket.



Extinguisher 220-383 \$239.99



## Seat Rail Fire Extinguisher Bracket & Quick-Release Mount

A fire extinguisher is a common sense necessity for any LBC owner. Having it both stationary and close at hand is critical. A lot of damage can occur in the time it takes you to retrieve it from the trunk, or fish it out from beneath the seat. Mounting your extinguisher to the front of the passenger seat rail frame keeps it secure, visible and accessible, while at the same time tucked conveniently out of the way of everyday use.

The Fire Extinguisher Seat Rail Bracket Set was designed to accept most fire extinguisher manufacturer metal brackets or the Quick-Release Mount. Premium hardware, L-Brackets and a purpose-made center bracket, allow for adjustment in both height and lateral positions. Installation instructions are included.

The Quick-Release Fire Extinguisher Mount attaches readily to the seat rail bracket, or will bolt to any flat surface. It is machined from billet aluminum, and has been anodized black. The quick-release mount uses a stainless steel lock pin (5 lbs release) with a red lanyard for better visibility and grabbing. The mount will accept extinguishers ranging from 2-¾" to 3-¼" in diameter. Installation instructions are included.

Fire Extinguisher Seat Bracket	220-386	\$69.99
Fire Extinguisher Quick-Release Mount	220-387	64.99
Chrome Fire Extinguisher - HalGuard	220-383	239.99

# ACCESSORIES

## A46 GARAGE & TOOLS



### Mini Jumper Cables

Just like our cars our jumper cables are small but surprisingly practical—they're 8-feet long. You may want to order a few of these. When you pull the pint-sized cables from their sturdy plastic case, the new road-side friends you're helping will want one of their own.

Mini Jumper Cables 900-061 \$22.99

### Battery Filler

Correct topping up of your battery is ensured with this vintage style battery filler. Simply insert the nozzle into the battery and press down onto the separators. The valve opens and automatically fills the battery cell to the correct level.



Vintage Battery Filler 163-400 \$8.99

### On-Board Battery Charger

Every sports car owner who only uses his car part of the year needs one of these, because deep discharge appreciably shortens battery life.



- Attaches permanently to battery tray or fender well, mounting hardware included
- Molded plastic sealed case resistant to water, gasoline, oil, solvents and acids
- Charges and maintains 12 volt batteries
- Totally automatic, if the battery drops 1 volt, the charger switches on, when fully charged it switches itself off
- Operates from any regular 110 volt outlet
- Dimensions: 5½" x 3½" x 1½"

Battery Charger 386-245 \$68.99

### Logo Shop Apron

Logo shop apron with adjustable straps and three deep pockets.



MG Logo 217-200 \$23.99



386-470



386-455

### Lighting Solutions by Striker Concepts

Striker products have been designed, engineered and delivered to our professional customers innovation, technology and the best functionality. Striker products produce a crisp bright white light that illuminates a large surface area making them the most versatile of task lights.

**TriLight Motion-Activated LED** - The TriLight screws into a regular light bulb socket, but is 3.8 times brighter than a conventional bulb. It has three individually adjustable panels, each delivers 3,000 lumens, and has a life of 50,000 hours. You can use it with a wall switch or its built-in ultra-sensitive motion sensor.

**FLEXiT LED Light** - The FLEXiT Light is a hands free, flexible LED task light. The base holds two large magnets for attaching the light to metal surfaces. Or hang it or wrap FLEXiT to an object. FLEXiT uses 16 LEDs and can operate in low, medium and high settings. Includes 3 AAA batteries. Size: 0.85" x 7" x 13"

TriLight Motion-Activated LED	386-470	\$129.99
FLEXiT LED Light	386-460	39.99



386-460

**FLEXiT LIGHT™**



368-475

**STRIKER**

**Light Mine Professional Magnetic Light** - A super-bright work light, a red beacon light, a magnetic pick up tool - all in the palm of your hand! The Light Mine Pro is about the size of a baseball, has 8 bright white LEDs on one side and 4 red LEDs on the reverse, and has 11 magnets. The 4 light functions are low power spot, high output flood, red night vision, and red signal beacon. Powered by 3 AAA batteries included.

**Rover Mobile Task Light** - The Rover is compact, lightweight, and of course is extremely durable. It features an aluminum head that acts as a fully functional heat sink. The steel exoskeleton also acts as a stable base, or frame to hang the light. There is a universal tripod mount. It is powered by dual lithium-ion rechargeable batteries for plenty of power, and long run times. Recharge by simply inserting the supplied USB cable into the plug on the back. Once aimed, it can be cycled through 4 modes (High, Low, Strobe and SOS).

Light Mine Professional Magnetic Light	386-455	\$27.99
Rover Mobile Task Light	386-475	49.99



### Fender Covers

Our top quality fender covers are imprinted with the logo of your marque. Foam backing.

MG Logo	241-725	\$23.99
Austin-Healey Logo	241-735	23.99



### Moss Gripper Fender Cover

Protective fender cover grips the paintwork and will not slip.

Moss Fender Cover 990-991 \$38.99



800-667-7872

\*See ordering page for details

WWW.MOSSMOTORS.COM

# ACCESSORIES

GARAGE, TOOLS, CARE & MAINTENANCE **A47**



## X-Treme Quick Fix Tape

X-Treme tape was developed for the military and has some very unique properties. The silicone-based tape will stick only to itself, and only when placed under tension.

Once wrapped around an object, it forms a non-conductive, air- and water-tight, insulating seal that remains flexible within a temperature range of -60°F to 500°F and has a tensile strength of 600 psi. The tape can be repositioned within two minutes of wrapping and will start to bond immediately upon application. Black roll is 1" wide and 10' long (stretches to 3 times its length).

X-Treme Quick Fix Tape 221-590 \$8.99

## Form-A-Funnel

Patented tool diverts oil from the filter around skid plates, cross members, headers, or other obstacles for no-mess oil-changes. Quickly bends, molds and holds any shape so you can create the perfect channel for draining liquids.



- Moldable alloy core encapsulated in thick, pliable nitrile rubber can be reshaped and reused thousands of times
- Easy to clean and store
- Creates a leakproof seal around filters or drains
- Impervious to automotive fluids and works in temperatures from -30°F to 425°F
- Use with nearly any vehicle or equipment.

Form-A-Funnel 221-755 \$19.99



## Convertible Top Maintenance

The textured surface of a convertible top is challenging to keep clean and protected from the elements. The professional strength of Raggtop products extends the life of your top and keeps it looking new.

Top Cleaner 221-505 \$16.99  
 Fabric Protectant 221-510 27.99  
 Vinyl Protectant 221-515 21.89



## Novus Plastic Polish

#1 polish is for light scratches and aging. #2 polish is for restoring clarity by removing discoloration, haze and fine scratches. The #3 polish removes heavy scratches and abrasions. The #2 polish is required to finish after the #3 polish is used. Perfect for convertible top plastic windows.

#1 Clean & Shine 220-605 \$6.99  
 #2 Fine Scratch Remover 220-610 9.99  
 #3 Heavy Scratch Remover 220-615 11.49



## Castrol Oil Collectables

Classic Castrol oil cans look great in your den or garage.

½ Pint 216-545 \$14.79  
 1 Pint 216-555 21.99  
 2 Pint 216-565 27.99

## Oil Spill Mat

Don't let oil stain your garage or driveway. Roll out an absorbent Oil Spill Mat to catch the daily dribbles and engine maintenance spills.



Oil Spill Mat 221-605 \$23.99

## Classic Color Spray Paints

Paints are ozone friendly. Bare metal must be primed to achieve satisfactory results. 12 oz. aerosol cans. Ground shipping only.



Engine: Olive Green Engine to 1972 220-580 \$21.69  
 Engine: Black 1972 on 220-575 16.99  
 Engine Primer 220-576 14.99  
 Wheel: Silver-Grey 220-560 21.69  
 Dash & Wiper: Black Wrinkle 220-570 19.99



## Renovo Soft Top Care



The best care you can give to your fabric or vinyl convertible top. Water-based Renovo products clean, waterproof and revive tired tops safely.

Fabric Top Dry Cleaner 220-260 \$14.99  
 Water & Stain Proofer, 1 L 220-265 26.99  
 Water & Stain Proofer, 500 mL 220-280 15.99  
 Vinyl Top Cleaner, 500 mL 220-285 13.99  
 Vinyl Top Protector, 500 mL 220-290 13.99  
 Black Fab. Top Reviver, 1 L 220-250 44.99  
 Black Fab. Top Reviver, 500 mL 220-270 24.99



## Simichrome Metal Polish

Highly recommended polishing paste for brass, aluminum and chrome. Leaves a super shine with a protective film for lasting brightness.

Simichrome 225-350 \$18.99



## Connolly Hide Care

This is the famous "Hide Food," only the name has changed. Apply once a month to keep leather clean, soft and luxurious. Made in England.

Connolly Hide Care 220-210 \$38.99

## Spray Adhesive

Our contact adhesive has a very high heat resistance and bonds firmly to insulation and sound-deadening material, carpet, headliners and many automotive surfaces. One advantage of this spray that we really like is that it goes on as a web rather than a stream for a more complete and consistent coverage. 12 fl. oz.



Spray Adhesive 409-037 \$19.99



### Water & Gas Don't Mix



If you use modern gas that has Ethanol blended in, and you don't drive your classic very often, the ethanol attracts water in your vented tank which in turn forms rust and sludge, impairing performance. We've got three products to help:

#### Prevent with PEP Fuel Treatment

PEP fuel treatment is a fuel preservative formulated with antioxidants and de-gumming agents to help fight sludge, resin deposits and gum from forming in your fuel tank. Modern ethanol-blended gasoline has a shelf life of 30-45 days in a vented tank, PEP fuel treatment increases that to 60 days. PEP fuel treatment should be mixed with the fuel every time you buy gas. Keep a bottle handy in your trunk. An 8 oz bottle treats 80 gallons. If you are storing your vehicle with gasoline in the tank, use 1 oz for every five gallons.

#### Test with Water Probe Indicator

Using a dip stick that will pass all the way to the bottom of your fuel tank, apply the Indicator to the very tip of the dip stick. The Indicator will turn red to show the exact level of water in your tank. Water collects at the very bottom of your tank.

#### Emulsify with E-Zorb Treatment

E-Zorb emulsifies the water you've found in the bottom of your fuel tank, and mixes the water and ethanol back into the fuel. The water will pass with the gasoline through your filter and into your engine, finally leaving as steam. E-Zorb should be mixed in the ratio 1 ounce to 20 gallons of gasoline, so one pint bottle of E-Zorb will treat 320 gallons. It will be necessary to agitate the fuel treatment in your tank by rocking your car from side to side and up and down.

PEP Fuel Treatment	220-361	\$13.99
Water Probe Indicator	220-362	12.99
E-Zorb Fuel Treatment	220-355	29.99



### Auto Dry Blade

This 11½" water wand swipes away surface water. The soft silicone contours to your vehicle's shape and glides over any paint surface without scratching the finish. Produces 15% less friction than terrycloth.

Auto Dry Blade 231-674 \$18.99



### Professional Car Duster

100% cotton dusting mop is treated with special wax to trap dust. Simply shake it out and it's ready to use again. 20" long. Comes with a protective carrying case.

Professional Duster 231-670 \$20.99



### Wire Wheel Brush

If your car has wire wheels, you need this brush! Shaped to get around the spokes without damaging your knuckles, this heavy-duty brush makes light work of cleaning your wire wheels.

Wire Wheel Brush 386-940 \$6.89



### Convertible Top Cleaning Brush

Natural horse hair brush is nonabrasive, naturally soft, durable and exclusively designed to gently remove exterior debris from fabric and vinyl convertible tops.

Horse Hair Cleaning Brush 221-530 \$19.99

### Collector's Choice Engine Oil



Collector's Choice engine oil is a must for your classic engine. Contains higher zinc and phosphorus levels to help prevent premature camshaft lobe wear, additives to help prevent seals from becoming hard and leaking from infrequent use, and antioxidants to combat the effects of humidity changes during storage that can lead to moisture and even rust in an engine. 12 quarts in a case. Not for use with catalytic converters.

20W-50, quart	220-815	\$9.99
20W-50, case of 12	220-810	\$99.99

### Dashpot Oil

Specifically designed for both SU and Zenith carbs, this oil will ensure your car's proper performance. 125 mL.

Dashpot Oil 220-225 \$11.99



### Shock Absorber Fluid

Custom blended specifically for British Girling and Armstrong lever action shock absorbers. Convenient flip-open pouring spout for easy refills. 16 fl. oz.

Shock Fluid 220-304 \$17.99



### Transmission Oil

Effective in all manual transmissions. Also improves copper corrosion protection to prolong the life of brass and bronze synchro rings, bushes, and thrust washers. 1 qt.

Transmission Oil (non-OD) 220-145 \$27.99



### WaterWetter

A wetting agent that helps coolant "bond" to metal surfaces thus increasing heat transfer. Highly recommended for all climates.

WaterWetter 220-115 \$19.99





## "Ultra Slick" Engine Assembly Lube

Use "Ultra Slick" during assembly of camshafts, lifters, engine bearings, timing components, valves and guides and rocker shaft assemblies.

Assembly Lube 221-565 \$9.99



## ReLead & Stor-N-Start

ReLead replaces the valve lubricating qualities of lead formerly used in gas. Stor-N-Start is an additive that prevents deposits from forming in fuel lines and carburetors.

ReLead 220-390 \$24.99  
Stor-N-Start 220-375 9.99



## Lead Substitute with Octane Booster

Effective valve and valve seat protection plus a powerful octane booster that will raise octane rating by as much as five points depending on the type of gasoline.

Lead Substitute - 12 oz. 220-366 \$10.89



## Brake Lube

This grease aids in the assembly of natural and/or synthetic rubber components.

Brake Lube, 5 g. 220-443 \$2.59  
Brake Lube, 500 g. 220-444 19.99



## Permatex Disc Brake Quiet

Apply to the back of your brake pads to eliminate brake squeal. Compatible with anti-lock brake systems and brake pads that do not have anti-squeal shims. Protects against corrosion. Comes in a package of two .25 oz. packets.

Disc Brake Quiet 583-825 \$6.99



## Corroseal Rust Converter

Rust. Is there a more deplorable four-letter word? Corroseal is the best way to deal with rust because it is less expensive, less time consuming and is more environmentally friendly than sandblasting. Corroseal Rust Converter chemically alters rust (iron oxide) into magnetite, a stable substance. It also primes the surface with a high-quality latex metal primer at the same time. Corroseal truly provides one-step corrosion control.

- Water-based rust converter with high-quality latex metal primer
- Non-flammable
- Non-corrosive
- Easy to apply (brush, roll or spray)
- Easy to clean-up with soap and water

Corroseal Rust Converter 232-205 \$33.99



## Copaslip Anti-Seize Compound

This anti-seize is highly recommended for wire wheel splines and knockoff threads. The Molybdenum formulation reduces galling and corrosion to improve the life of wire wheels and hubs. Wheel and hub surfaces should be cleaned and relubricated at least once per year as part of a regular maintenance program.

57 g. (2 oz.) Tube 221-405 \$13.99  
250 g. (8.8 oz.) Jar 221-410 27.99



## ZDDPlus Engine Oil Additive



After 70+ years of trouble-free, metal to metal engine protection, the E.P.A. is forcing ZDDP (Zinc Dialkyl Dithio Phosphate = Zinc and Phosphorus) out of domestic motor oil. If your engine was designed prior to the 1990s, your non-roller lifters require ZDDP in your motor oil to avoid premature deterioration. Don't let your lifters run metal-to-metal. Add the 4 fluid ounce contents of this ZDDPlus bottle at every 4 to 5 quart oil change. Not for use with catalytic converters.

ZDDPlus, each 220-805 \$12.99  
ZDDPlus, case of 25 220-908 274.99



## HYLOMAR®

### Hylomar Sealants & Assembly Adhesives

Hylomar Limited manufactures a wide range of high-performance sealants and adhesives used by some of the leading OEMs in the world. Hylomar products are also widely used and respected in the automotive, aerospace and industrial aftermarket.

**Hylomar M** was originally the Racing Formulation. It is acetone-based, stiffens slightly over time and can be used in place of a gasket between finely machined surfaces. This product comes in a tube and an aerosol.

**Hylomar Advanced Formulation (AF)** is solvent-free, won't harden and is perfect for use with gaskets on parts that need to be removed regularly for service. AF fills imperfections on mating surfaces, thus forming a seal.

**Hylolyte RED** is a semi-hardening gasket and jointing compound offering improved gap-filling capabilities. The product is resistant to a wide range of fluids, especially water (including salt water and steam), anti-freeze and synthetic oils. It forms an instant seal, has a heat-activated curing system and is methylene chloride free.

**Hylomar Exhaust Assembly Paste (EAP5)** seals joints in exhaust systems and lubricates joints during fitting.

**Hylomar Cleaner** removes used Hylomar gasket and jointing compound from disassembled joints. The unique mix of solvents also make it perfect for cleaning and degreasing surfaces prior to use with any of Hylomar's range of adhesives and sealants. It is also very effective at removing uncured anaerobic adhesives, uncured silicone and uncured epoxy products.

Hylomar M - 80ml Tube	232-220	\$21.99
Hylomar M - 200ml Aerosol	232-225	29.99
Hylomar AF - 85g Tube	232-215	26.99
Hylolyte RED - 80ml Tube	232-230	23.99
Hylomar EAP5 - 140g Tube	232-235	7.99
Hylomar Cleaner - 400ml Aerosol	232-240	14.99

# ACCESSORIES

**A50** CARE, MAINTENANCE & ACCESSORIES



## Brake Fluids

### Castrol LMA & Lockheed Brake Fluid:

Both LMA brake fluids exceed all factory DOT specifications. Compatible with all British brake systems.

### Silicone Brake Fluid:

Will not absorb moisture from the air like ordinary brake fluids, resulting in longer life for brake cylinders and hoses. One quart is sufficient for fluid change in one car.

Lockheed 500 mL	220-400	\$6.99
Castrol 12 oz.	220-455	6.59
Castrol gal. can	220-505	64.99
Silicone Brake Fluid - 1 liter	220-412	24.99



## Ultra-Torque Lubricant by ARP

ARP's Ultra-Torque lubricant has been specifically designed to reduce tension, preload scatter and eliminate the need to cycle high performance engine fasteners before final installation.

Ultra-Torque Lubricant - .5 oz.	322-815	\$3.89
---------------------------------	---------	--------

## ZDDP ZPaste™ Camshaft & Lifter Assembly Lube

**MORE INFO ONLINE**

ZPaste™ Camshaft & Lifter Assembly Lube is specifically intended for the special break-in requirements of flat-tappet engines. ZPaste™ is a proprietary formulation of Zinc Dialkyl DithioPhosphate (ZDDP) types with a Molybdenum DiSulfide (MoS2) additive in a new formulation Calcium Sulfonate base. It's extreme adhesion allows it to remain in place on critical engine parts for long periods of time. ZPaste™ is designed to be used along with ZDDPlus™ for initial engine break-in. Single use packets are enough paste for a single camshaft installation, paste is designed for use on cam lobes and tappets only.



Single Use, 1 Camshaft	220-806	\$8.99
------------------------	---------	--------

## SAE 90 GL4 Gear Oil by Dynolite

**NEW**



Our classic cars require special fluid and oil formulations, in particular, gear oil. Newer GL5 oils have too high of a sulfur content which erodes yellow metals such as bronze or brass, which are commonly used in British applications. Our cars require a GL4 type oil and this Dynolite Gear Oil is perfect for our classics.

SAE 90 GL4 - 1 Liter	225-306	\$9.99
----------------------	---------	--------

## Supercool by Dynolite

Supercool coolant additive is specially formulated to enhance cooling system performance.



- Improves heat transfer properties of your coolant
- Suitable for cast iron, aluminum, copper-brass and bronze cooling systems
- Formulated with a corrosion inhibitor
- Compatible with all water base coolants

Supercool	220-117	\$14.99
-----------	---------	---------



## Fuel Tank Restoration

### Step 1: Cleaner

We recommend using this bio-degradable cleaner in conjunction with the etching liquid when planning to seal a fuel tank. 1 gal.

### Step 2: Etcher

Use this bio-degradable etcher as a prep to our slushing compound to give maximum adhesion of the sealer. Our tank cleaner should be used first to remove oils or grime. 16 fl. oz.

### Step 3: Slushing

This slushing compound fluid puts a protective film on the entire inside surface of your fuel tank to prevent rust and eventual fuel line blockage. Tanks should be cleaned with #220-620, then etched with #220-630.

Cleaner	220-620	\$48.99
Etcher	220-630	22.99
Slushing	220-450	53.99

## Expandable Cup Holder

Our retractable cup holder mounts nearly anywhere. The arms adjust in or out to the size of your container, and it folds up when not in use.



Black	222-090	\$12.99
-------	---------	---------

## Drink Holder

Oversized 3¼" diameter opening will receive most any cup and hold it securely. Sturdily constructed and flocked in Charcoal Grey material to complement any interior. Best of all, it is secured in place by sliding over the edge of your floor mat, so you can use it in any automobile.



Large Drink Holder	100-785	\$27.99
--------------------	---------	---------



## Shoulder Strap Adjuster

Sliding clip adjusts a seat belt shoulder strap off of the neck and provides travel comfort for both drivers and passengers.

- Installs with a snap!
- Helps maintain upright position upon impact (U of Mich. Impact Tests)

Shoulder Strap Adjuster	231-860	\$6.99
-------------------------	---------	--------



## Logo Bar Stool

30" high, with padded 14" diameter seat covered with easy to clean vinyl. Chrome plated legs.

MG Logo	231-800	\$129.99
Austin Healey Logo	231-810	129.99

**MOSS**

**800-667-7872**

\*See ordering page for details

**WWW.MOSSMOTORS.COM**

# ACCESSORIES

APPAREL & REGALIA **A51**



Desk Mug

Travel Mug

## Thermal Mugs

Hot or cold drinks maintain their temperature in our new, British themed, brushed metal mugs. Spill and slip resistant, and available in travel and desktop styles.

### Travel Mug

MG Logo	230-856	\$23.69
Austin Healey Logo	230-926	23.69
Union Jack	230-946	23.69

### Desk Mug

MG Logo	230-857	\$23.69
Austin Healey Logo	230-927	23.69
Union Jack	230-947	23.69



## Castrol Tin Coffee Cup

Branded with the period Castrol logo this classic style tin mug has an enamel coating in Castrol classic green with white inner. Great for the garage, camping or out at your next car show.

### Features:

- Rugged Enamel Coating
- Chrome Polished Rim
- Dishwasher Safe
- 16 oz. Capacity

Castrol Coffee Cup	216-570	\$11.99
--------------------	---------	---------



## Classic Logo Knit Blankets

Keep the chill away while relaxing at home, or after a brisk night drive, with one of these heavy knit blankets. Made from an 80% cotton blend, their knit construction offers a feel as soft as a sweater. Yet, these heavy weights measure 50" x 60" and weigh in at 3 1/2 pounds, providing you with a substantial buffer against the cold. These blankets are machine washable and made in the USA.

Austin Healey Script	231-315	\$109.99
MG Octagon	231-320	109.99



**NEW**

## Classic Logo Wine Glass Set

When raising a toast with friends, share your Sprite or Midget passion etched in glass. A set of four wine glasses makes for an amazing gift.

MG Octagon Wine Glass Set - 4 pc.	230-969	\$29.99
Austin Healey Wine Glass Set - 4 pc.	230-989	29.99



**NEW**

## Classic Logo Beer Glass Sets

This set of 4, full-pint, traditional beer glasses is great for those hot garage days - from Guinness to Lemonade. The guys will appreciate your pub-like style and ample serving size.

MG Octagon - 4 pc.	230-951	\$29.99
Austin Healey Script - 4 pc.	230-953	29.99



## Waterproof Picnic Blankets

These waterproof blankets bring a touch of comfort to any roadside picnic. Folded into a parcel, it can be easily stored and transported using its durable handle. When opened up, this blanket spreads out to a respectable 51" w x 70" l. They are constructed of gray acrylic with a foam layer and waterproof PEVA backing. Offered with your choice of either the Austin-Healey, MG or Moss logo.

Austin Healey Logo	231-385	\$29.99
MG Logo	231-375	29.99
Moss Logo	231-370	29.99



## Pendleton Motor Robe

Keep warm and cozy with our big 52" x 70" Pendleton Mills 100% virgin wool blanket. Woven in a traditional Scottish plaid, it will keep you free from drafts and provide a touch of comfort at roadside picnics.

Red Lap Robe	231-400	\$129.99
--------------	---------	----------



## Heated Blanket

Keep your passenger toasty with this 12V heated blanket. 42" x 58". Requires negative ground lighter socket.

Electrically Heated Blanket	002-842	\$46.99
-----------------------------	---------	---------



## Classic Logo Scarves

Brave the elements while showing appreciation for your LBC with one these knit scarves. Made from an 80% cotton blend, their sturdy knit construction offers a feel as soft as a sweater. They are machine washable and made in the USA. Measures 8 1/2" x 80"

MG Octagon	231-340	\$49.99
Austin Healey Script	231-341	49.99



# ACCESSORIES

A52 APPAREL & REGALIA

**NEW**



J



A

B



G

H

I



C

D

E

F

## Premium Embroidered Hats

These superbly crafted embroidered hats provide a deep low fit which allows them to stay on at high speed. The adjustable velcro closure ensures a secure, personalized, fit. Offered in a variety of styles and colors, you're certain to find the perfect one to help keep the sun and wind from diminishing your fun!

### Features:

- 100% Cotton Construction
- Contoured Visors
- Matching Color Sweatbands
- Matching Fabric Adjustable Velcro Closure
- Premium Embroidered Designs

A. Tan/Navy - MG Safety Fast	219-933	\$19.99
B. Tan/Navy - Austin Healey Script	219-934	19.99
C. White with Navy Sandwich Visor - MG	219-816	19.99
D. Navy with White Sandwich Visor - MG	219-819	19.99
E. Tan with Green Sandwich Visor - MG	219-817	19.99
F. Black with White Sandwich Visor - MG	219-818	19.99
G. Navy with Red Sandwich Visor - Sprite MkII Half-Jack	219-938	19.99
H. Navy with Red Sandwich Visor - Sprite MkII Half-Jack	219-941	19.99
I. Navy with Red Sandwich Visor - Midget Half-Jack	219-939	19.99
J. Navy/Red - Austin Healey Script	219-834	19.99



Back J



Back A & B

Back G, H, & I

## Classic Logo Performance Polo's

Stay in your comfort zone with one of our light weight Performance Polo's. Moisture-wicking and highly breathable, they will keep you dry and cool whether you're out for a drive, at a show or just working in the garage. These navy-blue polo's come sporting either the classic Austin Healey Script or MG Octagon logo. They feature tag-less construction and are machine washable.



### Austin Healey Script Logo

Medium	217-364	\$49.99
Large	217-365	49.99
X-Large	217-366	49.99
XX-Large	217-367	49.99

### MG Octagon Logo

Medium	217-360	\$49.99
Large	217-361	49.99
X-Large	217-362	49.99
XX-Large	217-363	49.99



MG Octagon



Austin Healey



## MG Octagon 45mm Chronograph Watches

These great looking chronograph style watches have a 45mm precision machined silver alloy case, sport a mineral glass crystal face, stainless steel bezel and a stainless steel positive clasp band for great looks, easy viewing and durability. They come packaged in an elegant black tin presentation case for easy gift giving.

### Features:

- High quality quartz movement from Japan for accuracy and longevity.
- Fully functional 1/10 second chrono capability up to 60 minutes that provides accurate timing at home or at the track.
- Self-luminous hour markers, hour hand and minute hands with a red second hand for a sporty look and great night-time visibility.
- Logos are raised/embossed and high polished to a jewelry finish for premium good looks.
- Includes a 3 year limited factory warranty. See the enclosed factory warranty papers for specific details and conditions.

MG Octagon Watch 231-311 \$139.99



Back

Front

## BMC Service & Sales T-Shirt

The "retro style" is in fashion so show off your BMC loyalties with this 100% cotton t-shirt that features a logo based off a vintage dealership sign.

Medium	013-705	\$21.99
Large	013-706	21.99
XLarge	013-707	21.99
XXLarge	013-708	24.99

## Logo Earrings

Brightly enameled miniature marquee logos.



MG Logo 219-730 \$12.99



800-667-7872

\*See ordering page for details

WWW.MOSSMOTORS.COM



229-896      229-887      229-888



229-896    915-326    915-327    229-897    229-898    915-328

## Engraved Metal Key Fobs

You'll love the sleek beauty of our latest Keychain Fobs. Engraved with your favorite British icon and available in three distinctive styles.

### Leather & Bar

MG Logo	229-896	\$13.69
Austin Healey Logo	915-326	13.69
Union Jack	229-886	13.69

### Leather & Teardrop

MG Logo	229-897	\$13.69
Austin Healey Logo	915-327	13.69
Union Jack	229-887	13.69

### Solid Metal

MG Logo	229-898	\$13.69
Austin Healey Logo	915-328	13.69
Union Jack	229-888	13.69



## Key Fobs

Cloisné Union Jack	229-885	\$6.79
MG Brown	229-802	8.99
MG Black	229-801	8.99
Austin-Healey Brown Leather	915-316	8.99
Austin-Healey Black Leather	915-315	8.99



## Cloisné Union Jack

Designed to mount on flat surfaces. 2 1/4" x 1 3/8". Screws included.

Cloisné Union Jack - Pair	229-308	\$27.99
---------------------------	---------	---------



## Parking Only Signs

9" x 12" silk-screened aluminum.

Sprite Logo	215-970	\$26.99
MG Logo	215-761	19.99



## Factory Dealer Signs

Multicolored and superbly screen printed, these signs look exactly like the rare originals!

MG Service (12" x 16")	214-321	\$22.99
AH Service (6" x 24")	214-310	28.89
Austin-MG (12" x 48")	214-210	48.99



## Magnetic Country Oval Tags

Show your allegiance with a magnetic badge - either to a country or to your frame of mind. Protective UV coating will protect your oval from fading or yellowing.

GB	230-112	\$9.99
----	---------	--------



## Magnetic Union Jack

No holes required. 3" x 6".

Magnetic Union Jack	215-330	\$5.99
---------------------	---------	--------



**NEW**

## Lighted Signs

These distinctive lighted signs are sure to catch the eye of your fellow LBC enthusiasts. Their classic look and exceptional quality make them perfect for displaying anywhere from the den, office or garage. Their steel box housing is powder coated in a durable black satin finish. Backlit with modern LED's, the sign emits a clean and even light that will reservedly enhance these classic British designs. Measures: 21 3/4" x 6 3/4" x 3 1/4" with a 48" cord length. Made in the USA.

MG Safety Fast	231-350	\$199.99
MG Car Company	231-352	199.99
Austin Healey	231-353	199.99



## Classic Flying Helmet & Goggles

Reproduction of the helmets and flying goggles worn by WWII pilots of the Royal Air Force.

RAF Goggles	219-945	\$179.99
RAF Helmet, Large	219-990	179.99
RAF Helmet, X-Large	219-995	179.99



## Union Jack Flag

Made of light-weight polyester with metal grommets on the hoist.

Union Jack Flag - 5' x 3'	217-070	\$21.99
---------------------------	---------	---------

# ACCESSORIES

A54 REGALIA



**Road Racing at Brooklands**  
214-572



**British Classics**  
214-570



**RAC (12"x12")**  
214-567



**Weber Carburetors**  
214-562

## Vintage Metal Signs

Add a bit of nostalgia to your garage or den with any one of these classic British metal signs. Made by hand in the USA, these heavy duty signs are manufactured from 24 gauge steel, and printed using dye-sublimation for a durable and very detailed finish. Take your pick from several vintage designs. All signs measure 12" x 16" except where noted.

Only **\$19.99**



**MG Safety Fast**  
214-556



**Keep Calm and Motor On**  
214-568



**BP**  
214-561



**Avon Tyres**  
214-566



**Lucas**  
214-564



**Motul**  
214-565



**MG Sales & Service**  
214-555



**Union Jack**  
214-552



**Lockheed**  
214-563



**Austin Genuine Parts**  
214-551



**MG Service**  
214-553



## MG Octagon Decorative Magnet

Bring some of your passion for the MG into your garage or home with this MG Octagon logo magnetic badge. Their classic charm makes these black and white enameled badges a great way to personalize your toolbox, refrigerator or whatever you like. Badges measure approximately 2 1/4" x 2 1/4".

MG Octagon 201-037 \$8.99



## Embroidered Patches

Add a splash of British pride to jackets, sweaters, caps, and anything else you can think of.

Large MG - 5"	229-505	\$9.89
Brown MG - 3"	229-495	5.89
Small MG - 2 3/4"	229-500	6.89
British Leyland - 2 1/2" x 3"	229-560	7.49
BMC Rondell - 2 3/4"	229-570	6.79
Union Jack - 3 3/4" x 2 3/4"	229-510	5.89

## Cloisonné Pins

Colorful cloisonné pin of your favorite marque or other cool logos, perfect for your hat or jacket.

MG Octagon Pin - Red	229-250	\$8.99
MG Octagon Pin - Black	229-245	8.99
Austin-Healey Wings	229-710	8.99
Austin-Healey Round Pin	229-720	8.99
Healey Castle Flag Pin	229-230	8.99
Lucas Prince of Darkness Pin	229-255	6.99



800-667-7872

\*See ordering page for details

WWW.MOSSMOTORS.COM

# ORDERING & Shipping

## DELIVERY DAYS:

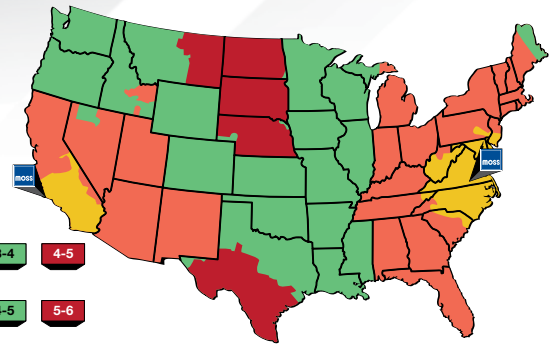

## AREAS / APPROXIMATE GROUND DELIVERY TIME (In Working Days)

- This map represents approximate working days for Ground Delivery. (As quoted by our carriers, not guaranteed.)
- It also assumes we can ship from the nearest warehouse. Items shipped from an alternate warehouse will take longer.

## SHIPPING

- Shipping is calculated on the regular retail price before any discounts.
- Orders received by 3 p.m. local time are normally shipped same day when shipped by UPS Ground Preferred or UPS Air.
- We will ship by Ground Saver unless an alternate shipping method is specified.
- Alaska, Hawaii, Puerto Rico must choose either AK/HI/PR Saver or UPS Air (see info below shipping chart).

## OVERSIZE PARTS FEE **OS**

Some items are oversized and are indicated by the oversize parts fee icon. An oversize parts fee (per item) will be applied to your order. This fee will still be charged on free shipping orders. You can find the amount of the fee by visiting MossMotors.com or calling 800-667-7872. The oversize parts fee will not be charged on orders that ship by truck freight (under \$1,400) or those that qualify for free truck freight (over \$1,400).

## TRUCK SHIPMENT FEE **TRUCK**

- Some parts must be shipped truck freight. Orders under \$1,400 will be charged a flat \$159 shipping fee.
- ORDER OVER \$1,400 AND MOSS PICKS UP THE SHIPPING!**

## PO BOX, A.P.O. OR F.P.O.

- A.P.O., F.P.O. and P.O. Box orders are not guaranteed and will be shipped via USPS.

## GUARANTEED UPS AIR DELIVERY SERVICE (48 STATES)

- Moss guarantees that orders received before 3 p.m. your local time will arrive on time or shipping and handling charges will be refunded (barring weather problems, or "Acts of God").
- UPS 2nd Day Air** - Guaranteed to be delivered by end of day the second business day.
- UPS Next Day Air** - Guaranteed to be delivered by 10:30 a.m., noon or end of day the next business day, depending on destination.
- Saturday Delivery** - Available on UPS Next Day Air and UPS 2nd Day Air orders for an additional \$16.00 and is not available in all areas.
- Orders shipped by air that are over 40 lbs., by weight or dimensions, we reserve the right to charge actual shipping and will notify you in advance.

## FOREIGN ORDERS

Foreign orders are charged actual shipping charges. Shipping quotes provided on request on orders over \$100. Duties and taxes are your responsibility. First time foreign orders may need to be paid by wire transfer. There is a \$10 charge to cover shipping and handling costs for catalogs shipped outside of the U.S. and Canada. One catalog per request.

## CANADIAN ORDERS

Canadian orders are shipped by Air Post if possible. For shipping charges on orders under \$700 please see the last column of the shipping chart below. Orders under \$700 that are heavier than 40 lbs. (by weight or dimensions) and orders over \$700 will be charged actual shipping. If you require a shipping method other than Air Post we will provide a quote upon request on orders over \$100. Duties and taxes are your responsibility. First time Canadian orders may need to be paid by wire transfer.

## Shipping, Insurance & Handling Chart US Rates - 48 States (AK\*, HI\* & PR\*)

Order Total	Ground Saver*	Ground Preferred†	2nd Business Day Air	Next Business Day Air	Canada Air Post**
\$10.00 to 20.00	\$5.99	\$12.49	\$24.99	\$42.99	\$12.99
20.01 to 50.00	7.99	15.49	32.99	52.99	16.99
50.01 to 75.00	9.99	18.49	39.99	61.99	22.99
75.01 to 100.00	13.99	20.99	46.99	74.99	27.99
100.01 to 150.00	18.49	24.99	55.99	86.99	35.99
150.01 to 200.00	22.99	27.99	62.99	97.99	43.99
200.01 to 300.00	24.99	30.99	73.99	108.99	55.99
300.01 to 500.00	24.99	33.99	84.99	119.99	74.99
500.01 to 700.00	24.99	35.99	93.99	129.99	94.99
700.01 and Up	<b>Free UPS (1)</b>	<b>Free UPS (1)</b>	73.99	108.99	TBD
1,400.01 and Up	<b>Free Truck (2)</b>	<b>Free Truck (2)</b>	84.99	119.99	TBD

† Ground Saver (default shipping method) - Ships by most economical method. May add 1-2 days.  
 †† Ground Preferred - Ships by UPS and is normally shipped same day if ordered by 3pm local time.

\* Alaska, Hawaii and Puerto Rico

UPS Air - Add \$8 to the 2nd Business Day & Next Business Day Air Rates.

AK/HI/PR Saver - Subtract \$9 from the 2nd Business Day Air Rates

(Ships by most economical method and may take longer.)

1 Free Ground UPS Shipping in the contiguous 48 states. Truck Shipments under \$1,400 will be charged a flat \$159 shipping fee.

2 Free Ground UPS/Truck Shipping in the contiguous 48 states only.

\*\* Canada Chart Shipping rate is for orders under \$700 and less than 40lbs. Orders under \$700 that are heavier than 40lbs. and orders over \$700 will be charged actual shipping.

## PAYMENT

- We have a \$10 minimum parts order, excluding tax and shipping.
- We accept certified check, money order, and the following credit cards:
- CA and VA residents add sales tax.
- Due to increasing fraud, some foreign orders may require additional documentation to process your order.



## WHEN YOUR ORDER ARRIVES

- Please remember to inspect your parts immediately upon receipt of your order.
- Should your order arrive in damaged condition, immediately inform a Moss Motors customer service representative at 1-800-689-9313.
- Claims for damage during shipping must be reported within 3 days of receipt of order.
- Keep original box and packing material.
- If your order was shipped truck freight, note damage on the bill of lading when signing the delivery receipt.
- If there are any other questions about your order, contact customer service within 10 days.

## SPECIAL ORDER & DIRECT SHIP PARTS

- Require pre-payment by cashiers check or credit card and may not be cancelled or returned.

## BACKORDERS

- Occasionally, we are out of stock on some items, which we will ship to you as soon as available.
- Backorders are shipped free but carry a handling charge of \$2.29 per \$25 of value. (The combined total for original order shipping, and all backorder handling fees, shall never exceed the total shipping charges quoted on the shipping chart on this page.)
- You may request "No Backorders" or cancel backorders at any time prior to shipping.
- We do not backorder to any foreign countries, including Canada.
- Backorders are sent by the most cost effective method, not necessarily the same method as the original order.

## WARRANTY - THE LONGEST IN THE BUSINESS!

- All Classic British products are warranted to be free from defects in material and workmanship for 2 years from the date of invoice.
- All superchargers, supercharger components, and supercharger hardware are warranted to be free from defects in material and workmanship for 1 year from date of invoice.
- Moss Motors, Ltd. will, at its discretion, repair or replace any part that fails in service within the warranty period. This warranty does not cover labor, failure of related components, normal wear of brake or clutch components or failure resulting from alteration, misuse, accidental damage, faulty installation, or faulty repair.
- Warranty requests should be submitted to our sales department and must be supported by the original Moss Motors purchase invoice and documentation of the failure.

## PRICES

We do everything possible to hold prices. Prices occasionally change without prior notice.

## RETURNS

- You may return new and uninstalled products in resalable condition for a full refund excluding shipping and handling charges for up to 6 months from date of invoice.
- Returns over 6 months, but less than 12 months will be charged a 10% restocking fee to cover our processing costs, in-house credit will be given on account usable on future orders. We reserve the right to charge up to 20% when no invoice is supplied and/or there is substantial work involved to process your return back to stock.
- Items over 12 months old are not returnable.
- To return a part, follow the instructions printed on the back of the invoice.
- Make sure to package the products carefully to avoid damage during return and include all original packaging and a copy of the invoice and ship to our California address.
- Refunds will not be issued for installed, damaged, incomplete, "Custom", or "Special Order" or "Direct Ship" items.
- If a return is due to our error, we will reimburse reasonable freight charges. We will not reimburse additional charges for shipping/packaging services. Electrical items that have been installed are not returnable.

## CATALOG ERRORS

Every effort has been made to provide accurate information. We reserve the right to correct typographical errors and will not be held liable for inaccuracy of pricing, descriptions or applications.

## TERMS AND CONDITIONS & PRIVACY POLICY

See inside back cover for more information.

## FREE SHIPPING

Free Ground shipping in the contiguous 48 states. Oversize Parts Fee still applies. Truck shipments will be assessed a one time fee of \$159. Truck shipments over \$1,400 ship free.

## SAME DAY SHIPPING

Orders received by 3 p.m. local time are normally shipped same day when shipped by UPS Ground Preferred or UPS Air. Does not apply to special orders and some oversized items.

## OVERSIZE PARTS FEE

Some items are oversized and are indicated by the oversize parts fee icon or an underlined part number. An oversize parts fee (per item) will be applied to your order. This fee will be charged on free shipping orders. You can find the amount of the fee by visiting MossMotors.com or calling 800-667-7872. The oversize parts fee will not be charged on orders that ship by truck freight.



123-456

## PHONE ORDERS

US 800-667-7872 INTL 805-681-3400

## FAX ORDERS

805-692-2525

## ONLINE ORDERS

MossMotors.com

## CUSTOMER SERVICE

800-689-9313



# ORDER WORKSHEET

Please Print

Customer No. \_\_\_\_\_

Name \_\_\_\_\_

Street \_\_\_\_\_

City/State \_\_\_\_\_ Zip \_\_\_\_\_

Daytime Phone \_\_\_\_\_ Fax \_\_\_\_\_

Email \_\_\_\_\_



Mail To: Moss Motors  
440 Rutherford St.  
Goleta, CA 93117  
Fax To: 805-692-2525

Ship To \_\_\_\_\_

Street \_\_\_\_\_

City/State \_\_\_\_\_ Zip \_\_\_\_\_

	Part No.	Description	Qty.	Unit Price	Ext. Price
1.					
2.					
3.					
4.					
5.					
6.					
7.					
8.					
9.					
10.					
11.					
12.					
13.					
14.					

Charge My:  Visa  Mastercard  Amex  Discover

Card Number \_\_\_\_\_

Date Card Expires \_\_\_\_\_

Enclosed Is \$ \_\_\_\_\_

For Terms and Conditions & Privacy Policy see inside back cover.

Check YES if you wish to backorder any items not currently stocked. You will not be charged for backordered items until they are shipped.

Yes  No

Parts Total

Sales Tax  
(CA & VA Only)

Shipping

Oversize Fee

Total

## FREE CATALOGS

- Austin Healey 100
- Austin Healey 100-6
- Austin Healey 3000
- Austin Healey Sprite
- Triumph TR2, 3, 4 & 4A
- Triumph TR250 & TR6
- Triumph TR7 & TR8
- Triumph Spitfire & GT6
- MG TC, TD & TF
- MGA
- MGB & MGC
- MG Midget
- Classic Mini (Online)
- Jaguar XK120-140-150, XJ6-12, XJS, E-Type (Online)
- Mazda Miata/MX-5

Get your FREE catalog by calling 800-667-7872 or request one online at [www.mossmotors.com](http://www.mossmotors.com)





# Sprite / Midget Restoration Parts Catalog

## TABLE OF CONTENTS

<b>MANUALS &amp; BOOKS</b>		2
<b>PRODUCTION DATA</b>	Identifying your car	3
<b>TECH. SPECIFICATIONS</b>	Car information	4-5
<b>ENGINE</b>	Engine, 948-1275 Engine, 1500 Engine accessories	6-13 14-16 17
<b>COOLING &amp; HEATING SYSTEM</b>	Radiator, fan, pump & hoses Heaters	18-19 20-21
<b>ENGINE CONTROLS</b>	Control cables	21
<b>FUEL SYSTEM</b>	Carburetors Pumps Tanks	22-24 26 27
<b>EXHAUST / EMISSION CONTROL</b>	Emission control Manifold, pipes, muffler	25 28-33
<b>DRIVELINE</b>	Clutch Gearbox, 948-1275 Gearbox, 1500 Differential & Driveshaft	34-35 36-39 40 41
<b>STEERING</b>	Steering wheels Steering rack assemblies	42 41
<b>SUSPENSION &amp; WHEELS</b>	Front suspension Rear suspension Road wheels	44-45 46 47
<b>BRAKES</b>	Master cylinders Drum brakes Disc brakes Handbrake Pipes, fluid, tools	48 49 50 50 51
<b>BODY PANELS &amp; FITTINGS</b>	Body panels, outer Body panels, inner Windshields Body fittings, Bugeye Body fittings, 1961-'80 Body mouldings, Midget Plugs, grommets, badges, mirrors Door windows / Sidecurtains Bumpers Door fittings	52-53 54 55 56-57 58-60 61 62-63 64-65 66-67 68
<b>ELECTRICAL</b>	Wipers / Washers Headlamps other Lamps Wiring harnesses & wiring fittings Distributors Ignition Battery, Misc. electrical Generator / Alternator Starter	69 70 71-72 73 74-75 76 77 78 79
<b>DASHBOARD</b>	Gauges & Cables Dashboard	79 80-81
<b>SOFT TRIM</b>	Panel kits & Carpets Cockpit fittings Seats Tonneau covers Tops	82 83 84-85 86-87 88-89
<b>TERMS AND CONDITIONS &amp; PRIVACY POLICY</b>		90

## About This Catalog

This catalog covers parts for U.S.-specification left hand drive cars. In producing this catalog, our primary goal was to publish a listing of Sprite & Midget parts which was as comprehensive, accurate and informative as possible for the U.S. market. In doing this, we have made every effort to correctly identify and include every part likely to be needed to repair, restore or maintain your car. Although some of the parts listed are not currently available, our Product Development staff is constantly seeking new suppliers and manufacturers of quality reproductions of otherwise obsolete items. The current Moss Motors website ([www.mossmotors.com](http://www.mossmotors.com)) pricing is always the best indication of availability.

Local laws and regulations relating to pollution, safety and lighting equipment vary considerably from state to state and country to country. Since we distribute parts for these cars on a worldwide basis, we are not in a position to advise what laws are in effect in each locality. We strongly encourage anyone contemplating any modifications to a vehicle intended for street use, to check local regulations before proceeding. We strongly suggest that you save all old stock equipment should reinstallation be necessary at a future date.

**NOTE: In the body of this catalog, items with indented descriptions are components of the non-indented kit or assembly above them.** When an indented component is "NA", it is still included in the assembly, but not available separately.

## Supersession and Rationalization of Parts

Most owners of British cars have, at one time or another, ordered an original "factory" part from an authorized dealer, only to find that the part received was different from the original, although it did work. This is the result of the supersession or rationalization of parts by the factory. Supersessions occur when a part is modified, and the original design or pattern is no longer produced. If old and new parts are interchangeable, even though they may appear slightly different, the old part is superseded by the new part. Rationalization is an attempt by the factory at efficiency in which one new part replaces several original parts, after which the original parts are no longer available.



This "no airplane" symbol indicates that the item(s) may not be shipped by air, and must be shipped by ground.



This truck symbol indicates that the item is shipped by truck, freight collect, payable on delivery.

123-456

Underlined part numbers indicate an Oversize Parts Fee will be charged. See [mossmotors.com](http://mossmotors.com) or call for details.

## WARNING!

Working on automobiles is inherently dangerous. Moss Motors, Ltd. is not liable for injury or damage due to incorrect installation or use of their products. All products are sold with the understanding that the safe and proper installation and use of the products is the customer's responsibility. Follow factory workshop manual procedures and instructions, but use current shop safety standards and common sense. Some tasks will require professional advice or services which Moss Motors cannot provide.



By special licensing agreement with British Motor Heritage Ltd., Moss Motors, Ltd., is a fully authorized manufacturer and distributor of British sports car spares. With official support from the original manufacturer, we are able to produce a wide range of reproduction spares which meet or exceed the original factory standard of quality. In conjunction with British Motor Heritage, Ltd., Moss Motors is dedicated to the preservation and restoration of British sports cars. The British Motor Heritage, Ltd. and marque trademarks, as well as some exploded view artwork included in this publication, are the property of British Motor Heritage, Ltd., and are reproduced under licensing agreement by Moss Motors, Ltd.



## Sprite-Midget Parts Catalog

© Copyright Moss Motors, Ltd. April, 1979  
Edition SPM-100 August, 2018  
Printed in the USA

All rights reserved. No part of this publication may be reproduced, stored in a retrieval system, or transmitted in any form or by any means, electronic, photocopying, recording, or otherwise without the prior written permission of Moss Motors, Ltd.

# Manuals & Books

## Factory Workshop Manual Reprints

Bugeye Sprite	212-465	\$59.89
Sprite MkII on Midget to '74	212-475	\$64.89
Midget 1500	212-415	\$69.99



## Haynes Workshop Manual

Excellent guide to Sprite/Midget tune up and maintenance.  
212-380 \$29.99

## Glovebox Size Workshop Manual

Though not as complete as the full factory manuals, this clever new manual is packed with information. Tune up data, repair and rebuilding information, dimensions and torque specs are all here in this compact 5-1/2" x 8-1/2" book.  
212-480 \$34.99



## Bentley Workshop Manual Reprints

Bentley manual reprints are the ultimate shop reference, as they contain both the factory workshop and owners' manuals. The most complete and authoritative manuals available!

948 & 1098	212-330	\$79.99
1275	212-340	\$79.99



## Midget & Sprite Essential Buyer's Guide

This book is the perfect companion for the first-time or even more experienced buyer. All the information is here to help make a clear and balanced decision, to counter the vendor's claims, and even negotiate a better price. The author has bought and sold many MG Midgets & A-H Sprites over the years, and his knowledge and enthusiasm will prove a vital resource for potential buyers. 5.5" x 7.5", 64 pages, 100 color photos.  
213-671 \$19.99



## Owners' Manual Reprints

Sprite MkI (Bugeye)	212-690	\$19.89
MG Midget 1968-'72	212-705	\$22.99
MG Midget 1975-'78	213-310	\$22.99
MG Midget 1979-'80	213-320	\$21.99



## Restoring Sprites & Midgets

by Grahame Bristow

Now you can restore Your Sprite or Midget with the help of this comprehensive and entertaining book. Packed with detailed practical information, photographs, illustrations, and technical specifications. Softbound, 8" x 10-3/4", 210 pages.

213-305 \$49.99



## Original Sprite & Midget

This looks like a coffee table book and reads like one too - but its easily accessible information is nothing less than what you want. Loaded with original specifications, colour schemes and factory options and dates. This book may be written for easy reading and may be readable by anyone - but the serious (or 'soon-to-be serious') enthusiast will recognize how valuable this information is. Hardbound, approx. 9"x12", 144 pages, over 225 color photographs.

211-406 \$49.99

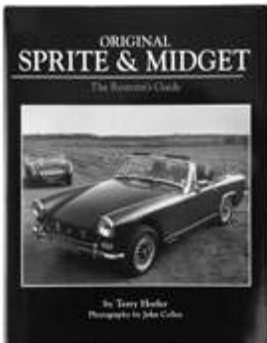

## Tuning A Series Engines

by David Vizard.

New 3rd Edition. Highly detailed and complete coverage of building and tuning tips. Originally written for the Mini owner, this is a "must-have" for every A-Series Sprite and Midget owner. Hardbound, 8-1/2" x 11", 520 pages.  
212-160 \$51.99

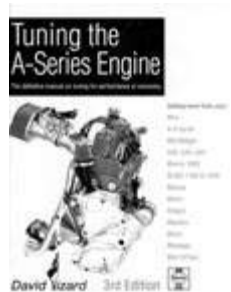

## Identification Numbers

When ordering parts it is essential to identify your car exactly. Since the changes made by the factory in the course of production have been followed over the years by individual changes made by each owner, it can be extremely difficult in some cases to correctly identify some of the components of your car. To compound the problem, some states title a car by its year of sale rather than the year of its manufacture. In order to make it as easy as possible for you to give us the information we need to supply you with the proper parts, we have found that the common practice of referring to the car series by its engine size ("948, 1098, 1275, & 1500") works quite well and have adopted this system for our listings where possible. Where further detail seemed necessary, we have used the "Mark Series" and "model year" (which should not be confused with the build date). In a few cases, especially in the later cars, we have cited engine and body numbers.

For the sake of simplicity we delete the alpha numeric prefix from the change points in our application. Example G-AN4-72033 is (c)72033. These letters will pinpoint certain production features but will not affect the application of individual parts as listed. Considering the few remaining "original" Sprites and Midgets, this seems to be a rational system that covers most applications.



## Engine Identification

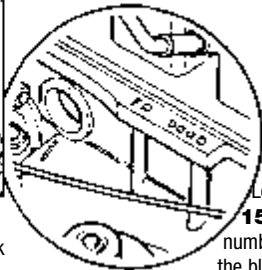

Location of **948, 1098, 1275 engine** number stamped in the block

Location of **1500 engine** number-stamped in the block

Example: **9 CG/ U/ H 12345**

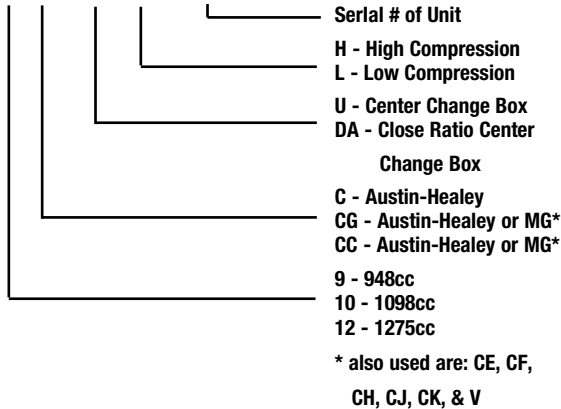

Note: The serial numbers on Sprite and Midget engines do not match the chassis or body numbers.

There are several good published sources of Sprite/Midget production data. Some variation occurs due to inconsistencies in factory record keeping and individual interpretation of available data. Production dates are sometimes confused with model year dates. The factory kept no running totals. The entire Sprite/Midget production came from Abingdon except for 489 Sprites and 476 Midgets which were built at Cowley in 1967. These "Cowley" vehicles may carry an "M" suffix.

## Chassis Numbers

The chassis number is stamped on a plate secured to the left-hand inner wheel arch valance under the hood and provides basic information about your car.



Example: **H AN5 L 12345**

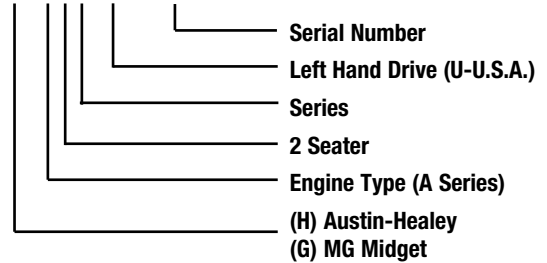

Note: An additional prefix was used from 1970 to indicate the model year.

## Production Information (for USA)

Model Year    Build Date    1st Car of model year    Model

### Midget

	Jun 1961	G-AN1-101	MkI (948)
	Sep 1962	G-AN2-16184	MkI (1098)
	Mar 1964	G-AN3-25788	MkII
1967	Oct 1966	G-AN4-52390	MkIII (1275)
1968	Nov 1967	G-AN4-60441	MkIII
1969	Dec 1968	G-AN4U-66226	MkIII
1970	Sep 1969	G-AN5UA-74886	MkIII
1971	Jun 1970	G-AN5UB-89515	MkIII
1972	May 10, 1971	G-AN5UC-105501	MkIII
1973	Jul 13, 1972	G-AN5UD-123731	MkIII
1974	Aug 23, 1973	G-AN5UE-138801	MkIII
1975	Nov 19, 1974	G-AN6UF-154101	1500
1976	Aug 1975	G-AN6UG-166301G	1500
1977	Dec 14, 1976	G-AN6UH-188001G	1500
1978	Aug 24, 1977	G-AN6UJ-200001G	1500
1979	May 9, 1978	G-AN6UL-212001G	1500
	Dec 7, 1979	G-AN6-229526	last Midget

(There seem to have been no "official" 1980 model year Midgets, although some USA cars are titled as such.)

### Sprite

	Mar 31, 1958	H-AN5-501	MkI ("Bugeye")
	Feb 1961	H-AN6-101	MkII (948)
	Sep 1962	H-AN7-24732	MkII (1098)
	Mar 1964	H-AN8-38829	MkIII (1098)
1967	Oct 1966	H-AN9-64735	MkIV (1275)
1968	Nov 1967	H-AN9-72034	MkIV
1969	Dec 1968	H-AN9-77591	MkIV

(Sprite exports were stopped for all foreign markets in early 1969, although production for the home market continued until July 6, 1971.)

## BUGEYE SPRITE

## 948 SPRITE MKII,MIDGET MKI

## 1098 SPRITE MKII,MIDGET MKI SPRITE MKII,MIDGET MKII

<b>Vehicle Identification</b> .....	HAN5 .....	HAN6,GAN1 .....	HAN7,GAN2 / HAN8,GAN3
Vehicle Number Location .....	LH FT FRAME .....	LH FT FRAME .....	LH FT FRAME
Engine Number Location .....	RH FT .....	RH FT .....	RH FT
Gearbox Number Location .....	TOP CASE .....	TOP CASE .....	LH CASE
Rear Axle Number Location .....	LH TUBE .....	LH TUBE .....	LH TUBE
<b>Tune Up</b>			
Engine Firing Order .....	1342 .....	1342 .....	1342
Valve Rocker Clearance .....	.012 COLD .....	.012 COLD .....	.012 COLD
Static Ignition Timing .....	5 BTDC .....	4 BTDC .....	5BTDC
Dynamic Ignition Timing .....	.....	.....	8BTDC @ 600RPM
Timing Mark Location .....	BOTTOM TIMING COVER .....	BOTTOM TIMING COVER .....	BOTTOM TIMING COVER
Distributor Make/Type .....	LUCAS DM2 .....	LUCAS DM2P4 .....	LUCAS 25D
Contact Breaker (points) Gap .....	.014 TO .016 .....	.014 TO .016 .....	.014 TO.016
Rotation of Rotor .....	COUNTER CLOCKWISE .....	COUNTERCLOCKWISE .....	COUNTERCLOCKWISE
Dwell Angle .....	60 .....	60 .....	60
Ground Polarity .....	Positive .....	Positive .....	Positive
Ignition Coil Make/Type .....	LUCAS LA 12 .....	LUCAS LA12 .....	LUCAS LA12
Spark Plug Make/Type .....	CHAMPION N5 .....	CHAMPION N5 .....	CHAMPION N5
Spark Plug Gap .....	.024 TO .026 .....	.024 TO .026 .....	.024 TO .026
Carburetor Make/Type .....	SU H1 .....	SU HS2 .....	SU HS2
Carburetor Main Jet .....	.090 .....	.090 .....	.090
Carburetor Main Jet Needle .....	GG .....	V3 .....	GY (HAN7,GAN2), AN (HAN8,GAN3)
Carburetor Piston Spring .....	NONE .....	LIGHT BLUE .....	BLUE
<b>Vehicle &amp; Engine</b>			
Length .....	11' 5-1/4" .....	11' 5-5/8" .....	11' 5-5/8"
Width .....	4' 5" .....	4' 5" .....	4' 6-7/8" [4' 8-1/2" W/WHL]
Height .....	4' 1-3/4" .....	4',1-3/4" .....	4' 1-3/4"
Ground Clearance .....	5" .....	5" .....	5"
Track Front .....	3' 9-3/4" .....	3' 9-3/4" .....	3' 10-5/16"
Track Rear .....	3' 8-3/4" .....	3' 8-3/4" .....	3' 8-3/4" [3' 9-1/4" W/WHL]
Wheelbase .....	6' 8" .....	6' 8" .....	6' 8"
Turning Circle .....	31' 6" .....	32' 1-1/2" LH, 31' 2-1/2" RH .....	32' 1-1/2" LH, 31' 2-1/2" RH
Toe-In .....	0 TO 1/8" .....	0 TO 1/8" .....	0 TO 1/8"
Curb Weight .....	660 KG .....	1400 LBS .....	1466 LBS (HAN7,GAN2), 1490 LBS (HAN8,GAN3)
Original Tire Size .....	5.20 X13 .....	5.20 X13 .....	5.20 X 13
Original Tire Pressure Front (Cold) .....	18 .....	18 .....	18
Original Tire Pressure Rear (Cold) .....	20 .....	20 .....	20
Replacement Tire Size .....	145 SR 13 .....	145 SR 13 .....	145 SR 13
Engine Type .....	OHV .....	OHV .....	OHV
Engine Displacement .....	948cc .....	948 cc .....	1098 cc
Firing Order .....	1342 .....	1342 .....	1342
Compression Ratio .....	8.3:1 .....	9:1 .....	8.9:1
Engine Bore .....	2.478 .....	2.478 .....	2.543
Engine Stroke .....	3.00 .....	3.00 .....	3.296
Number of Cylinders .....	4 .....	4 .....	4
Oil Pressure Idle .....	10 TO 25 .....	10 TO 25 .....	10 TO 25
Oil Pressure Normal .....	30 TO 60 .....	30 TO 60 .....	30 TO 60
Ignition Type .....	POINT .....	POINT .....	POINT
Fuel System Type .....	CARB .....	CARB .....	CARB
Fuel Pump Make/Type .....	AC/SPHINX Y TYPE .....	AC/SPHINX Y TYPE .....	AC/SPHINX Y TYPE mechanical (HAN7,GAN2), SU AUF 200 electric (HAN8,GAN3)
Fuel Tank Capacity .....	7.2 .....	7.2 .....	7.2
Cooling System Capacity .....	12 PINTS .....	12 PINTS .....	12 PINTS
Sump Capacity .....	7.8 PINTS .....	7.8 PINTS .....	7.8 PINTS
Gearbox Capacity, non-overdrive .....	2.7 PINTS .....	2.7 PINTS .....	2.7 PINTS
Gearbox Capacity, overdrive .....	.....	.....	.....
Rear Axle Capacity .....	1-3/4 PINTS .....	1.8 PINTS .....	1.8 PINTS

	SPRITE MKIV,MIDGET MKIII	SPRITE MKIV,MIDGET MKIII	1500 MIDGET
<b>Vehicle Identification</b>			
Vehicle Identification	HAN9,GAN4	HAN10,GAN5	GAN6
Vehicle Number Location	LH FT FRAME	LH B PILLAR,LH W/S.	LH B PILLAR,LH W/S
Engine Number Location	RH FT	RH FT	LH REAR
Gearbox Number Location	LH CASE	LH CASE	RH TOP CASE
Rear Axle Number Location	LH TUBE	LH TUBE	LH TUBE
<b>Tune Up</b>			
Engine Firing Order	1342	1342	1342
Valve Rocker Clearance	.012 COLD	.012 COLD	.010
Idle Speed	700 [1000 '68 ON]	1000	700 TO 900
Static Ignition Timing	7 BTDC	7 BTDC	10 BTDC [2 ATDC CALIF.]
Dynamic Ignition Timing	10 BTDC @ 1000RPM	13 BTDC @ 1000	2 ATDC [10 BTDC '78 ON FED.]
Timing Mark Location	BOTTOM TIMING COVER	BOTTOM TIMING COVER	LH TOP
Distributor Make/Type	LUCAS 25D	LUCAS 25D	LUCAS 45DE4
Contact Breaker (points) Gap	.014 TO .016	.014 TO .016	
Rotation of Rotor	COUNTER CLOCKWISE	COUNTER CLOCKWISE	COUNTERCLOCKWISE
Dwell Angle	60	60	
Ground Polarity	Positive thru 1967, Negative from 1968	Negative	Negative
Ignition Coil Make/Type	LUCAS 11C 12 [HA12 '68 ON]	LUCAS HA 12	LUCAS 15C6
Primary Resistance	3 TO 3.4 OHMS	3 TO 3.4 OHMS	1.30 TO 1.45 OHMS
Spark Plug Make/Type	CHAMPION N9Y	CHAMPION N9Y	CHAMPION N12Y
Spark Plug Gap	.024 TO .026	.024 TO .024	.025
Carburetor Make/Type	SU HS 2	SU HS 2	ZENITH-STROMBERG 150CD4
Carburetor Main Jet	.090	.090	.100
Carburetor Main Jet Needle	AN [AAC '68,'69]	AAC [ABC '72 ON]	44A,45Q,45K,45R,BY CARB#
Carburetor Piston Spring	LIGHT BLUE	LIGHT BLUE	BLUE
<b>Vehicle &amp; Engine</b>			
Length	11' 5-5/8"	11' 4-1/2"	11' 9"
Width	4' 6-7/8" [4' 8-1/2" W/WHL]	4' 5-5/8" [4' 8-1/2" W/WHL]	4' 6-7/8" [4FT,8-1/2" W/WHL]
Height	4' 5/8"	4' 1/4"	4' 1/4"
Ground Clearance	5"	5"	3-1/4"
Track Front	3' 10-5/16"	3' 10-9/16" [3FT,10-5/16" W/WHL]	3' 10-9/16" [3' 10-5/16" W/WHL]
Track Rear	3' 8-3/4" [3' 9-1/4" W/WHL]	3' 9" [3FT 9-1/4" W/WHL]	3' 9" [3' 9-1/4" W/WHL]
Wheelbase	6' 8"	6' 8"	6' 8"
Turning Circle	32' 1-1/2" LH, 31' 2-1/2" RH	32' 1-1/2" LH, 31' 2-1/2" RH	32' 1-1/2" LH, 31' 2-1/2" RH
Toe-In	0 TO 1/8"	0 TO 1/8"	0 TO 1/8"
Unladen Weight	1,510 LBS [1,519 '68,'69]		
Curb Weight		1,701 LBS	1,849 LBS
Gross Weight			2,229 LBS
Original Tire Size	5.20X13 [145SR 13 RADIAL]	145SR 13	145 SR-13
Original Tire Pressure Front (Cold)	18 [22 RADIAL]	22	22
Original Tire Pressure Rear (Cold)	20 [24 RADIAL]	24	24
Replacement Tire Size	145SR 13		
Engine Type	OHV	OHV	OHV
Engine Displacement	1275 cc	1275 cc	1493 cc
Firing Order	1342	1342	1342
Compression Ratio	8.8:1	8.8:1 [8.0:1 '72 ON]	9:1 FED TO '77, 7.5:1 CA,FED'78'79
Engine Bore	2.78 IN	2.78IN	2.9
Engine Stroke	3.2 IN	3.2 IN	3.44
Number of Cylinders	4	4	4
Oil Pressure Idle	20	20	20
Oil Pressure Normal	40 TO 70	40 TO 70	40 TO 60
Ignition Type	POINT	POINT	ELECTRONIC
Fuel System Type	CARB	CARB	CARB
Fuel Pump Make/Type	SU AUF 206	SU AUF216	AC DELCO RA1
Fuel Tank Capacity	7.2	7.2 [8.6 '72 ON]	7.5
Cooling System Capacity	12 PINTS [7 PINTS '68 ON]	7 PINTS	11.4 PINTS
Sump Capacity	7.8 PINTS	7.8PINTS	9.6 PINTS
Gearbox Capacity	2.7 PINTS	2.7 PINTS	1.75 PINTS
Rear Axle Capacity	2.1 PINTS	2.1 PINTS	2.1 PINTS

# External Engine 948 - 1098

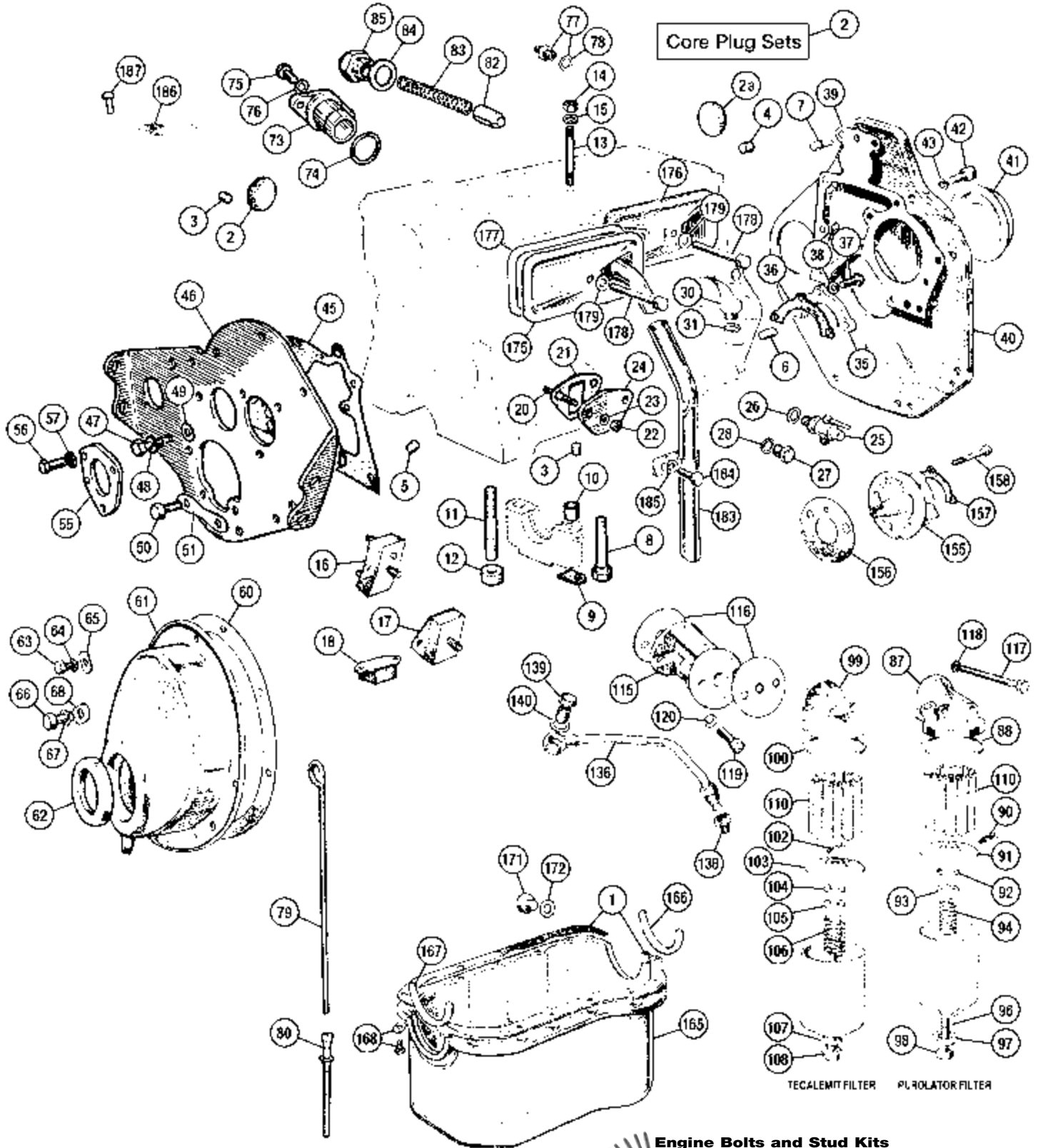

### Spin-On Oil Filter Adaptor

This Moss-designed filter head & pipe enables the use of a high capacity and economical spin-on filter.

235-875	\$99.99	Spin-on Adaptor
235-830	\$18.99	Filter, K&N
235-855	\$10.99	Filter, Wix
235-880	\$7.99	Filter, Fram

### Engine Bolts and Stud Kits

The head stud kit includes 11 studs. Factory engines used 9, some engines have been modified to use two more. Head studs and main cap studs are rated at 190,000 p.s.i., rod bolts at 180,000 p.s.i. Main bearing cap stud kit replaces original bolts.

948, 1098, 1275 Head Stud Kit	322-998	\$184.99
948, 1098, 1275 Main Bearing Cap Stud Kit	322-888	\$73.99

MOSS

MOSS MOTORS, LTD.  
TOLL-FREE ORDERS

1-800-667-7872

# 948 - 1098 External Engine

No.	Part No.	Price (each)	Description	Application	Qty. Req.
1	220-580	\$21.69	PAINT, correct olive green (spray can)		1
	296-655	\$5.89	SUMP GASKET (2 pcs.)		1
	296-661	\$31.99	GASKET SET, lower engine, Payen	} 948, early 1098 (10 CC)	1
	296-662	\$18.69	GASKET SET, lower engine **		1
	296-671	\$32.99	GASKET SET, lower engine, Payen	} late 1098 (10 CC)	1
296-672	\$15.99	GASKET SET, lower engine **	1		
** Products of various manufacturers supplied.					
2	328-248	\$2.69	CORE PLUG SET, steel	} thru (e)10CC/H3495	1
	328-249	\$19.29	CORE PLUG SET, brass		1
2a	328-253	\$3.79	CORE PLUG SET, steel	10CC/H3496 on	1
	328-230	\$0.79	CORE PLUG, steel	} thru (e)10CC/H3495	4
	328-231	\$4.99	CORE PLUG, brass		4
	328-235	\$0.99	CORE PLUG, steel	} 10CC/H3496 on	4
	328-236	\$3.99	CORE PLUG, brass		4
3	114-000	NA	PLUG, oil pressure		2
4	114-105	\$5.79	PLUG, oil gallery		4
5	461-300	\$0.59	RESTRICTOR, camshaft oil feed		1
6	325-080	\$1.49	DOWEL, lower		1
7	116-151	NA	DOWEL, upper		1
8	322-890	NA	BOLT, main bearing cap	} 948, 1098 (10CG)	6
9	114-015	\$0.99	LOCK TAB		6
10	NA	NA	COLLAR	} 1098 (10CC)	6
11	NA	NA	STUD, main bearing cap		6
12	021-634	\$0.69	NUT (all metal, self-locking)		6
13	329-715	\$5.69	CYLINDER HEAD STUD, long		4
	329-725	\$6.59	CYLINDER HEAD STUD, short		5
14	310-280	\$0.59	NUT, cylinder head, stock type		9
	114-122	\$2.99	NUT, cylinder head, flanged upgrade replacement		9
15	324-725	\$0.89	WASHER, head stud		9
16	413-160	\$5.19	ENGINE MOUNT, R/H & L/H		2
17	413-170	\$4.59	TRANSMISSION MOUNT, R/H & L/H		2
18	413-180	\$2.29	TRANSMISSION MOUNT, center		1
20	328-605	\$1.49	STUD, fuel pump / blanking plate		2
21	296-220	\$0.69	GASKET, fuel pump / blanking plate		1
22	310-140	\$0.24	NUT		2
23	365-730	\$0.25	WASHER		2
24	460-095	\$6.89	BLANKING PLATE	cars w/electric fuel pump	1
25	470-240	\$19.79	TAP, water drain		1
26	324-671	\$0.89	WASHER, fiber		1
27	328-180	\$13.79	PLUG, drain tap		1
28	324-626	\$0.79	WASHER, plug		1
30	116-153	\$4.49	PLUG, oil primer hole		1
31	116-154	\$0.89	WASHER, copper		1
35	NA	NA	REAR COVER, crankcase		1
36	116-155	\$0.99	GASKET, rear cover		1
37	322-230	\$0.19	BOLT, rear cover to block		3
38	324-020	\$0.20	WASHER, locking		3
39	116-159	\$1.39	GASKET, back plate		1
40	NA	NA	ENGINE PLATE, rear	948	1
	NA	NA	ENGINE PLATE, rear	1098 (10CG)	1
	NA	NA	ENGINE PLATE, rear	1098 (10CC)	1
41	NA	NA	COVER, oil pump		1
42	322-880	\$0.49	BOLT, back plate to block		7
43	365-730	\$0.25	WASHER, locking		7
45	114-004	\$1.89	GASKET, front plate		1
46	NA	NA	ENGINE PLATE, front		1
47	322-040	\$0.49	BOLT, front plate to block		2
48	365-730	\$0.25	WASHER, locking		2
49	365-720	\$0.29	WASHER, plain		2
50	114-032	\$1.49	BOLT, front plate to bearing cap		2
51	114-005	\$3.19	LOCK TAB		1
55	460-475	\$10.49	LOCK PLATE, camshaft		1
56	322-230	\$0.19	BOLT, lock plate to engine plate		3
57	462-385	\$0.19	WASHER, locking		3
60	296-510	\$1.69	GASKET, timing cover		1
61	NA	NA	TIMING COVER	948-1098	1
62	121-500	\$1.89	OIL SEAL, felt	948 to (e)9C-H37646	1
	120-000	\$1.49	OIL SEAL, rubber	from 948 (e)9C-H37647	1
63	320-990	\$0.69	BOLT, timing cover to engine plate		6
64	324-020	\$0.20	WASHER, locking		6
65	324-765	\$0.79	WASHER, oval		6
66	322-880	\$0.49	BOLT, cover to block		4
67	365-730	\$0.25	WASHER, locking		4
68	460-360	\$0.89	WASHER, oval		4
73	NA	NA	HOUSING, distributor		1
74	264-943	\$0.29	O-RING		1

75	322-230	\$0.19	BOLT, housing to block		1
76	462-385	\$0.19	WASHER, locking		1
77	836-566	\$13.49	UNION, oil pressure gauge pipe (incl. washer)		1
78	116-154	\$0.89	WASHER, sealing		1
79	NA	NA	DIPSTICK	948	1
	451-410	NA	DIPSTICK	1098	1
80	451-430	\$5.19	DIPSTICK TUBE	1098	1
82	460-155	\$1.79	VALVE, oil pressure release		1
83	329-185	\$1.59	SPRING, oil pressure release		1
84	324-800	\$0.49	WASHER, cap nut		2
85	460-870	\$3.99	CAP NUT		1
87	NA	NA	HEAD, filter, Purolator	} 948-1098 (10CG) 1098 (10CC)	1
	NA	NA	HEAD, filter, Purolator		1
88	021-467	\$1.79	SEAL, bowl to head	} Purolator Filters	1
90	326-052	NA	CIRCLIP, center bolt retaining		1
91	435-150	\$12.99	PLATE		1
92	435-560	\$0.69	WASHER, felt		1
93	435-570	\$0.59	WASHER, steel		1
94	329-205	\$2.19	SPRING, pressure plate		1
96	021-439	\$1.89	SEAL, center bolt		1
97	116-152	\$5.89	COLLAR, center bolt		1
98	NA	NA	BOLT, center		1
99	NA	NA	HEAD, filter, Tecalemit		} Tecalemit Filter
100	435-347	\$1.99	SEALING RING	1	
102	466-090	NA	CLIP, retaining	1	
103	435-150	\$12.99	PRESSURE PLATE	1	
104	435-560	\$0.69	SEALING WASHER, (felt)	1	
105	435-565	\$0.39	WASHER, flat	1	
106	329-230	\$4.99	SPRING	1	
107	460-805	\$0.99	SEAL, lower	1	
108	NA	NA	BOLT	1	
110	950-540	\$6.79	OIL FILTER, felt, various manufacturers	1	
	950-520	\$5.89	OIL FILTER, paper, var. manufacturers	1	
115	NA	NA	ADAPTOR, filter head to block	948 to (e)5066	1
	NA	NA	ADAPTOR, filter head to block	948 from (e)5067, 1098	1
116	296-565	\$0.99	GASKET		2
117	116-161	\$1.99	BOLT, filter head	948 to (e)5066	2
	116-160	NA	BOLT, filter head	948 from (e)5067, 1098	2
118	324-040	\$0.29	WASHER, locking		2
119	114-563	\$0.59	BOLT, adaptor to block		2
120	324-040	\$0.29	WASHER, locking		2
136	NA	NA	PIPE, oil filter head to block	948 to (e)5066	1
	NA	NA	PIPE, oil filter head to block	948 from (e)5067, 1098	1
138	NA	NA	ADAPTOR, pipe to oil filter head		1
139	114-045	\$38.99	BOLT, banjo		1
140	324-805	\$1.99	SEAL, copper		2
155	435-630	\$49.99	OIL PUMP, pin drive		1
156	114-059	\$0.89	GASKET, oil pump		1
157	114-056	\$2.89	LOCK TAB, oil pump		1
158	117-004	\$0.59	BOLT, oil pump		3
165	NA	NA	SUMP, oil		1
166	297-645	\$11.49	SUMP SEAL, rear (neoprene)	upgrade from cork	1
	297-646	\$1.09	SUMP SEAL, rear (cork)	} incl. in lower engine gasket set	1
167	297-640	\$6.99	SUMP SEAL, front (cork)		1
168	322-675	\$12.89	FITTING KIT, sump (oval washers, lockwashers, & bolts)		1
171	328-280	\$1.79	PLUG, oil drain, stock type		1
	328-282	\$16.79	PLUG, oil drain, magnetic	(option)	1
172	324-626	\$0.79	WASHER, drain plug		1
175	NA	NA	COVER, side, front, orig. type	948-early 1098 (10CG)	1
	114-022	NA	COVER, side, front, orig. type	late 1098 (10CC)	1
176	460-050	NA	COVER, side, rear, replacement	all (see note)	1
NOTE: Replacement cover requires bolt, seal and cup washer listed below for replacement cover.					
177	296-370	\$1.69	GASKET, cork, stock type	original covers	2
	296-375	\$2.99	GASKET, rubber	replacement rear cover	1
	296-377	\$27.99	GASKET PAIR, silicone	all	1
178	322-105	\$0.99	BOLT	original covers	2
	320-695	\$0.69	BOLT	replacement rear cover	1
179	324-315	\$0.29	WASHER, fiber	original covers	2
	324-335	\$1.39	SEAL, rubber	replacement rear cover	1
	324-345	\$1.19	CUP WASHER	replacement rear cover	1
183	NA	NA	PIPE, vent		1
184	322-880	\$0.49	BOLT	} 948-1098 (10CG)	1
185	365-730	\$0.25	LOCKWASHER		1
186	117-569	\$2.89	ENGINE NUMBER PLATE (blank)		1
187	325-245	\$0.89	RIVET, engine number plate		2

# External Engine 1275

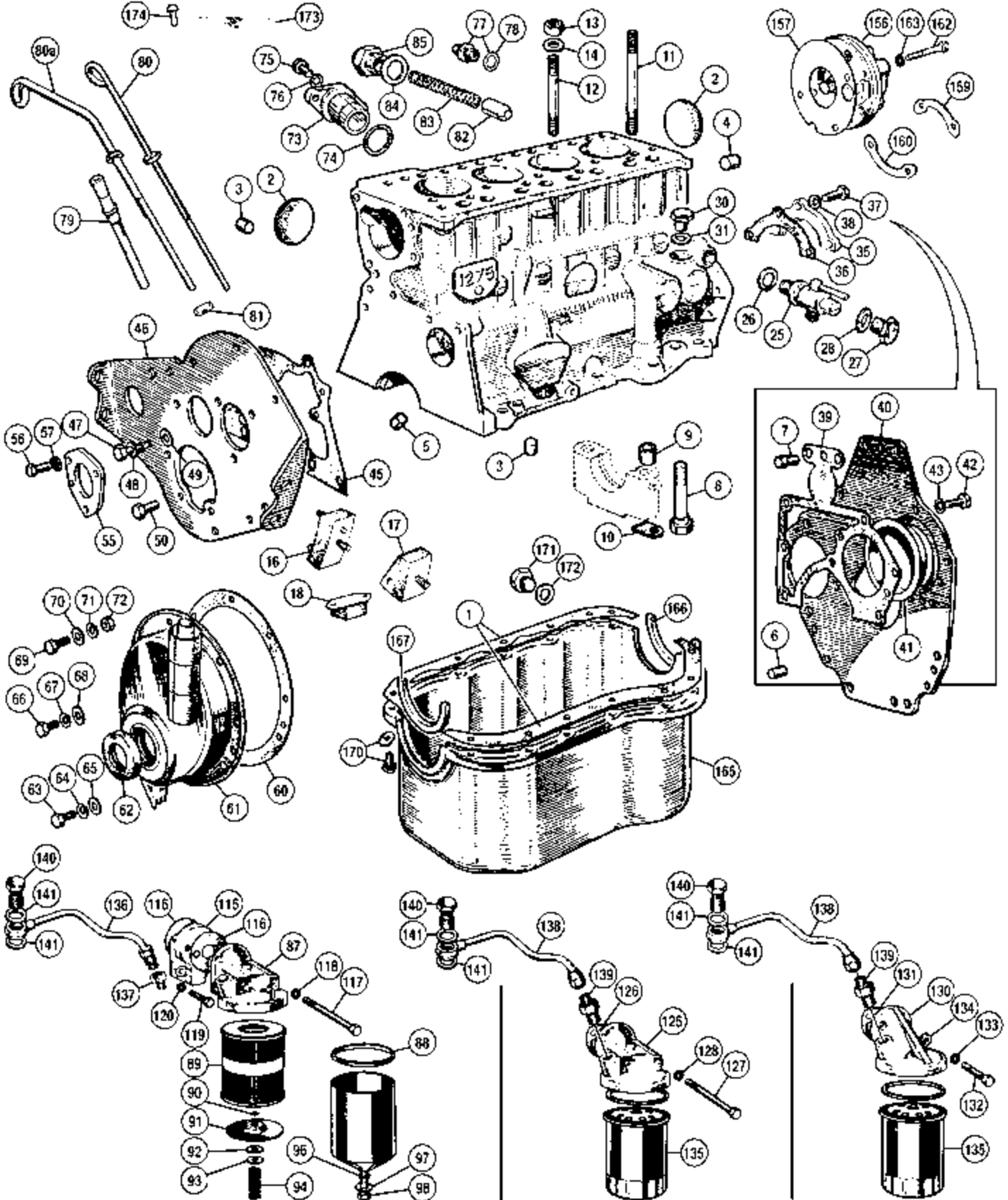

## Spin-On Oil Filter Adaptor

This Moss-designed filter head & pipe enables the use of a high capacity and economical spin-on filter.

235-875	\$99.99	Spin-on Adaptor
235-830	\$18.99	Filter, K&N
235-855	\$10.99	Filter, Wix
235-880	\$7.99	Filter, Fram

**MOSS**

**MOSS MOTORS, LTD.**  
TOLL-FREE ORDERS

**1-800-667-7872**



No.	Part No.	Price (each)	Description	Application	Qty. Req.
	220-580	\$21.69	PAINT, correct olive green (spray can)	12CC engines	1
	220-550	\$21.69	PAINT, metallic green (spray can)	12CD engines	1
	220-575	\$16.99	PAINT, black (spray can)	12V engines	1
	220-576	\$14.99	PRIMER, high temp. (use with engine paint)		1
1	296-665	\$3.49	SUMP GASKET (2 pcs.)		1
	296-681	\$32.99	<b>GASKET SET, lower engine, Payen</b>		1
	296-682	\$14.99	<b>GASKET SET, lower engine **</b>		1
			** Products of various manufacturers supplied.		
2	328-268	\$5.99	CORE PLUG SET		1
3	114-000	NA	PLUG, oil pressure		2
4	114-105	\$5.79	PLUG, oil gallery		4
5	461-300	\$0.59	RESTRICTOR, camshaft oil feed		1
6	325-080	\$1.49	DOWEL, lower		1
7	116-151	NA	DOWEL, upper		1
8		NA	BOLT, main bearing cap	early 12CC, early 12CD	6
	322-895	\$3.59	BOLT, main bearing cap	from late 12CC/CD - on	6
9		NA	COLLAR	early 12CC, early 12CD	6
	114-027	\$9.99	COLLAR	from late 12CC/CD - on	6
10	114-015	\$0.99	LOCK TAB	early 12CC, early 12CD	6
	322-998	\$184.99	HEAD STUD KIT, Uprated ARP		1
11	329-715	\$5.69	CYLINDER HEAD STUD, long		4
12	329-725	\$6.59	CYLINDER HEAD STUD, short		5
13	310-280	\$0.59	NUT, cylinder head, stock type		9
	114-122	\$2.99	NUT, cylinder head, flanged upgrade replacement		9
14	324-725	\$0.89	WASHER, head stud		9
16	413-160	\$5.19	ENGINE MOUNT, R/H & L/H		2
17	413-170	\$4.59	TRANSMISSION MOUNT, R/H & L/H		2
18	413-180	\$2.29	TRANSMISSION MOUNT, center		1
25	470-240	\$19.79	TAP, water drain		1
26	324-671	\$0.89	WASHER, fiber		1
27	328-180	\$13.79	PLUG, drain tap		1
28	324-626	\$0.79	WASHER, plug		1
30	116-153	\$4.49	PLUG, oil primer hole		1
31	116-154	\$0.89	WASHER, copper		1
35		NA	REAR COVER, crankcase		1
36	116-155	\$0.99	GASKET, rear cover		1
37	322-230	\$0.19	BOLT, rear cover to block		3
38	324-020	\$0.20	WASHER, locking		3
39	116-159	\$1.39	GASKET, back plate		1
40	116-156	\$269.99	ENGINE PLATE, rear		1
41	116-157	\$29.99	COVER, oil pump		1
42	322-540	\$0.69	BOLT, back plate to block		7
43	365-730	\$0.25	WASHER, locking		7
45	114-004	\$1.89	GASKET, front plate		1
46		NA	ENGINE PLATE, front		1
47	322-040	\$0.49	BOLT, front plate to block		2
48	365-730	\$0.25	WASHER, locking		2
49	365-720	\$0.29	WASHER, plain		2
50	114-032	\$1.49	BOLT, front plate to bearing cap		2
55	460-475	\$10.49	LOCK PLATE, camshaft		1
56	322-230	\$0.19	BOLT, lock plate to engine plate		3
57	462-385	\$0.19	WASHER, locking		3
60	296-510	\$1.69	GASKET, timing cover		1
61		NA	TIMING COVER		1
62	120-000	\$1.49	OIL SEAL, rubber		1
63	320-990	\$0.69	BOLT, timing cover to engine plate		6
64	324-020	\$0.20	WASHER, locking		6
65	324-590	\$0.19	WASHER, plain		6
66	322-880	\$0.49	BOLT, cover to block		4
67	365-730	\$0.25	WASHER, locking		4
68	460-360	\$0.89	WASHER, plain		4
69	314-265	\$0.49	BOLT, bracket to cover		1
70	324-590	\$0.19	WASHER, plain		1
71	324-020	\$0.20	WASHER, locking		1
72	310-760	\$0.39	NUT		1
73		NA	HOUSING, distributor		1
74	264-943	\$0.29	O-RING		1
75	322-230	\$0.19	BOLT, housing to block		1
76	462-385	\$0.19	WASHER, locking		1
77	836-566	\$13.49	UNION, oil pressure gauge pipe (incl. washer)		1
78	116-154	\$0.89	WASHER, sealing		1
79	451-430	\$5.19	DIPSTICK TUBE		1
80	451-410	NA	DIPSTICK, straight		1
80a	451-420	NA	DIPSTICK, bent		1
81	031-220	\$1.99	SEAL		1
82	460-155	\$1.79	VALVE, oil pressure release		1
83	329-185	\$1.59	SPRING, oil pressure release		1
84	324-800	\$0.49	WASHER, cap nut		2
85	460-870	\$3.99	CAP NUT		1

87		NA	HEAD, filter		1
88	021-467	\$1.79	SEAL, bowl to head		1
89	950-540	\$6.79	OIL FILTER, felt, various manufacturers		1
	950-520	\$5.89	OIL FILTER, paper, var. manufacturers		1
90	326-052	NA	CIRCLIP, center bolt retaining		1
91	435-150	\$12.99	PLATE		1
92	435-560	\$0.69	WASHER, felt		1
93	435-570	\$0.59	WASHER, steel		1
94	329-205	\$2.19	SPRING, pressure plate		1
96	021-439	\$1.89	SEAL, center bolt		1
97	116-152	\$5.89	COLLAR, center bolt		1
98		NA	BOLT, center		1
115		NA	ADAPTOR, filter head to block		1
116	296-565	\$0.99	GASKET		2
117	116-161	\$1.99	BOLT, filter head		2
118	324-040	\$0.29	WASHER, locking		2
119	114-563	\$0.59	BOLT, adaptor to block		2
120	324-040	\$0.29	WASHER, locking		2
125		NA	OIL FILTER HEAD, original		1
126	296-565	\$0.99	GASKET, filter head to block		1
127	116-161	\$1.99	BOLT, filter head (3 1/2" )		2
	116-160	NA	BOLT, filter head (3 1/4")		2
128	324-040	\$0.29	WASHER, locking		2
130	114-063	\$39.99	OIL FILTER HEAD, original		1
131	114-061	\$1.59	GASKET, filter head to block		1
132	116-162	\$1.69	BOLT, filter head to block (1 1/8" long)		2
133	324-040	\$0.29	WASHER, locking		2
134	324-860	\$0.19	WASHER, plain		2
135	950-045	NA	OIL FILTER, spin-on, "Crosland" brand		1
	950-545	\$4.49	OIL FILTER, spin-on, var. manufacturers		1
136		NA	PIPE, oil filter head to block	} Canister filter	1
137		NA	ADAPTOR, pipe to filter head		1
138		NA	PIPE, oil filter head to block	} Spin-on filter	1
139	116-163	NA	ADAPTOR, pipe to filter head, orig.		1
	116-164	NA	ADAPTOR, replacement †		1
	324-740	\$0.99	WASHER, copper, for 116-164 †		1
			† Replacement adaptor 116-164 must use washer 324-740		
140	114-045	\$38.99	BOLT, banjo		1
141	324-805	\$1.99	SEAL, copper		2
156	435-640*	\$34.99	OIL PUMP, star drive *	mounts w/ 2 bolts, fits all	1
157	114-059	\$0.89	GASKET, oil pump		1
159	116-150	\$0.89	LOCK TAB, pump upper	} 4 bolt pumps*	1
160	114-005	\$3.19	LOCK TAB, pump lower		1
162	114-687	\$0.69	BOLT, oil pump		4/2
163	324-020	\$0.20	WASHER, locking	2 bolt pumps*	2
165		NA	SUMP, oil		1
166	297-645	\$11.49	SUMP SEAL, rear (neoprene)	upgrade from cork	1
	297-646	\$1.09	SUMP SEAL, rear (cork)	} incl. in lower engine gasket set	1
167	297-640	\$6.99	SUMP SEAL, front (cork)		1
170	322-675	\$12.89	FITTING KIT, sump (oval washers, lockwashers, & bolts)		1
171	328-280	\$14.79	PLUG, oil drain, stock type		1
	328-282	\$16.79	PLUG, oil drain, magnetic (option)		1
172	324-626	\$0.79	WASHER, drain plug		1
173	117-569	\$2.89	ENGINE NUMBER PLATE (blank)		1
174	325-245	\$0.89	RIVET, engine number plate		2

\*Note: There were two different oil pumps for the 1275cc engine. The 'Concentric' brand pump is fixed in place by four bolts, whereas the 'Hobourn Eaton' pump uses two bolts. On the four bolt pump, a pair of lock tabs are used under the bolt heads, while the two bolt pump simply uses two locking washers.

## Heavy Duty Engine Bolts and Stud Kits

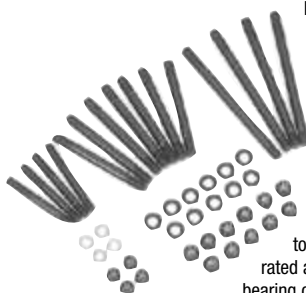

Keep your engine together with these heavy duty, high tensile strength precision ground engine hardware kits which include special hardened washers and nuts. These premium quality fastener kits are perfect for the racer, road warrior, or anyone who wants added insurance against mechanical failure. The head stud kit includes 11 studs. While factory engines used 9, some engines have been modified to use two more. Head studs and main cap studs are rated at 190,000 p.s.i., rod bolts at 180,000 p.s.i. Main bearing cap stud kit replaces original bolts.

948, 1098, 1275 Head Stud Kit	<b>322-998</b>	<b>\$184.99</b>
948, 1098, 1275 Main Bearing Cap Stud Kit	<b>322-888</b>	<b>\$73.99</b>
1275 Connecting Rod Bolt Kit	<b>322-838</b>	<b>\$162.99</b>

# Internal Engine 948 - 1098 - 1275

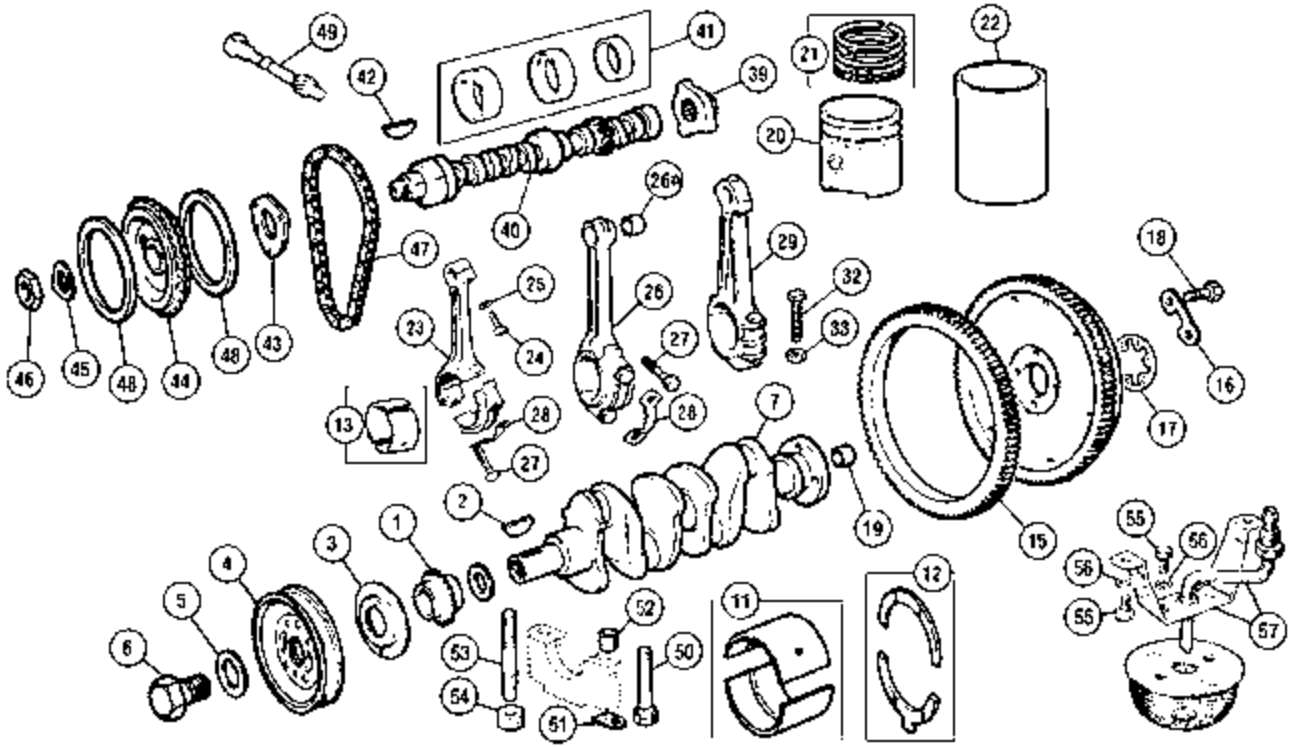

No.	Part No.	Price (each)	Description	Application	Qty. Req.
	328-635‡	\$31.99	ENGINE LOCKTAB SET	948 & 1098 (10CG)	1
	328-620‡	\$31.99	ENGINE LOCKTAB SET	1275	1
‡ Note: Locktab sets include all items marked ‡ below.					
1	460-435	\$24.99	CRANK SPROCKET, single	948 - 1098	1
	460-445	\$16.89	CRANK SPROCKET, double	1275	1
2	327-210	\$8.49	KEY		1
3	433-890	\$3.39	OIL THROWER		1
4	460-455	NA	PULLEY (may use 1275 pulley)	948 - 1098	1
	460-465	\$122.99	PULLEY with damper	1275	1
5	460-470‡	\$0.79	WASHER, lock tab		1
6	322-120	\$16.99	BOLT		1
7	451-565	NA	CRANKSHAFT	948	1
	451-570	NA	CRANKSHAFT	1098 (10CG)	1
	451-575	NA	CRANKSHAFT	1098 (10CC)	1
	451-585	NA	CRANKSHAFT	1275	1
11	425-105	\$37.99	MAIN BEARING SET, standard	948, 1.75" crank diameter (orig. 1.192" brg. width) (see note below) Bi-metal	1
	425-110	\$37.99	MAIN BEARING SET, .010"		1
	425-115	\$37.99	MAIN BEARING SET, .020"		1
	425-120	\$37.99	MAIN BEARING SET, .030"		1
	425-125	\$37.99	MAIN BEARING SET, .040"		1
Note: We and our suppliers now have only 1.067" wide bearings for 948 engines, which work fine. Bearings in the original width are no longer available.					
	425-161	\$45.99	MAIN BEARING SET, std., tri-metal	1098(10CG) 1.75" crank diameter 1.067" bearing width	1
	425-166	\$45.99	MAIN BEARING SET, .010", tri-metal		1
	425-171	\$45.99	MAIN BEARING SET, .020", tri-metal		1
	425-176	\$45.99	MAIN BEARING SET, .030", tri-metal		1
	425-181	\$45.99	MAIN BEARING SET, .040", tri-metal		1
	425-160	\$28.49	MAIN BEARING SET, std., bi-metal		1
	425-165	\$28.49	MAIN BEARING SET, .010", bi-metal		1
	425-170	\$28.49	MAIN BEARING SET, .020", bi-metal		1
	425-175	\$28.49	MAIN BEARING SET, .030", bi-metal		1
	425-180	\$28.49	MAIN BEARING SET, .040", bi-metal		1
	425-131	\$49.99	MAIN BEARING SET, std., tri-metal	1098(10CC) & 1275 2.00" crank diameter 0.985" bearing width	1
	425-136	\$49.99	MAIN BEARING SET, .010", tri-metal		1
	425-141	\$49.99	MAIN BEARING SET, .020", tri-metal		1
	425-146	\$49.99	MAIN BEARING SET, .030", tri-metal		1
	425-156	\$49.99	MAIN BEARING SET, .040", tri-metal		1
	425-130	\$27.69	MAIN BEARING SET, std., bi-metal		1
	425-135	\$27.69	MAIN BEARING SET, .010", bi-metal		1
	425-140	\$27.69	MAIN BEARING SET, .020", bi-metal		1
	425-145	\$27.69	MAIN BEARING SET, .030", bi-metal		1
	425-155	\$27.69	MAIN BEARING SET, .040", bi-metal		1
12	425-505	\$9.99	THRUST WASHER SET, standard	948	1
	425-520	\$6.79	THRUST WASHER SET, standard	1098 (10CG) Fed. Mogul "Glyco" brand,	1
	425-525	NA	THRUST WASHER SET, .003"		1
	425-530	NA	THRUST WASHER SET, .010"		1

No.	Part No.	Price (each)	Description	Application	Qty. Req.
	425-535	\$9.79	THRUST WASHER SET, standard	1098 (10CC) & 1275	1
	425-540	NA	THRUST WASHER SET, .003"		1
	114-074	\$19.99	THRUST WASHER SET, .005"		1
13	425-806	\$43.99	ROD BEARING SET, standard	Tri-metal (copper-lead-tin with babbit overlay, on steel backing)	1
	425-811	\$43.99	ROD BEARING SET, .010"		1
	425-816	\$43.99	ROD BEARING SET, .020"		1
	425-821	\$52.99	ROD BEARING SET, .030"		1
	425-805	\$24.89	ROD BEARING SET, standard		1
	425-810	\$24.89	ROD BEARING SET, .010"	Bi-metal (aluminum-tin, on steel backing)	1
	425-815	\$24.89	ROD BEARING SET, .020"		1
	425-820	\$24.89	ROD BEARING SET, .030"		1
	425-825	\$24.89	ROD BEARING SET, .040"		1
15	190-060	\$33.99	RING GEAR	948	1
	190-065	\$20.89	RING GEAR	1098	1
	190-070	\$20.59	RING GEAR	1275	1
16	460-405‡	\$1.39	LOCKTAB, flywheel	948 & 1098 (10CG engines)	2
	460-406	NA	LOCKTAB, flywheel	1098 (10CC engines)	2
17	460-415	\$6.59	LOCKTAB, flywheel	1275	1
18	322-500	\$2.49	BOLT, flywheel	948 & 1098	4
	322-505	\$3.69	BOLT, flywheel	1275	6
19	330-475	\$1.89	BUSHING, spigot	{ 948 thru early 12CC (5/8" O.D.)	1
	330-465	\$12.49	NEEDLE BEARING, spigot	later 1275 (3/4" O.D.)	1
20	420-100	\$249.99	PISTON SET, standard	948 C.R. 8.3:1	1
	420-105	\$249.99	PISTON SET, .020"		1
	420-110	\$249.99	PISTON SET, .030"		1
	420-115	\$249.99	PISTON SET, .040"		1
	420-120	\$249.99	PISTON SET, .060"		1
	420-125	\$249.99	PISTON SET, standard		1098 C.R. 8.9:1
	420-130	\$249.99	PISTON SET, .020"	1	
	420-135	\$249.99	PISTON SET, .030"	1	
	420-140	NA	PISTON SET, .040"	1	
	420-145	\$249.99	PISTON SET, .060"	1	
	420-150	\$229.99	PISTON SET, standard	1275 C. R. 8.8:1 Nüral-AE brand	1
	420-155	\$229.99	PISTON SET, .020"		1
	420-161	\$219.99	PISTON SET, .030"(aftermarket)		1
	420-165	\$229.99	PISTON SET, .040"		1
	420-170	\$229.99	PISTON SET, .060"		1

**MOSS** **MOSS MOTORS, LTD.** **1-800-667-7872**  
TOLL-FREE ORDERS

No.	Part No.	Price (each)	Description	Application	Qty. Req.
	420-151	\$219.99	PISTON SET, standard	1275 C. R. 8.8:1 aftermarket	1
	420-156	\$219.99	PISTON SET, .020"		1
	420-161	\$219.99	PISTON SET, .030"		1
	420-166	\$219.99	PISTON SET, .040"		1
	420-171	\$219.99	PISTON SET, .060"		1
21	421-620	\$64.99	RING SET, standard	948 4-ring (.070" & .125" width) Hastings brand	1
	421-625	\$64.99	RING SET, .020"		1
	421-630	\$64.99	RING SET, .030"		1
	421-635	\$64.99	RING SET, .040"		1
	421-640	NA	RING SET, .060"		1
	421-645	\$89.99	RING SET, standard	948 5-ring (.070" & .125" width) Hastings brand	1
	421-650	\$89.99	RING SET, .020"		1
	421-655	\$89.99	RING SET, .030"		1
	421-660	\$89.99	RING SET, .040"		1
	421-665	\$103.99	RING SET, .060"		1
	421-670	\$55.99	RING SET, standard	1098 4-ring Hastings brand	1
	421-675	\$55.99	RING SET, .020"		1
	421-680	\$55.99	RING SET, .030"		1
	421-685	NA	RING SET, .040"		1
	421-690	\$55.99	RING SET, .060"		1
	421-695	\$84.99	RING SET, standard	1098 5-ring	1
	421-700	\$84.99	RING SET, .020"		1
	421-705	\$84.99	RING SET, .030"		1
	421-710	\$84.99	RING SET, .040"		1
	421-715	\$84.99	RING SET, .060"		1
	421-720	\$59.99	RING SET, standard	1275 4-ring These fit only original factory pistons. Hastings brand	1
	421-725	\$59.99	RING SET, .020"		1
	421-730	\$59.99	RING SET, .030"		1
	421-735	\$59.99	RING SET, .040"		1
	421-740	\$59.99	RING SET, .060"		1
	421-750	\$69.99	RING SET, standard	1275 3-ring These fit replacement AE pistons #21251	1
	421-755	\$69.99	RING SET, .020"		1
	421-760	\$69.99	RING SET, .030"		1
	421-765	\$69.99	RING SET, .040"		1
	421-770	\$69.99	RING SET, .060"		1
22	426-090*	NA	CYLINDER LINER	948	4
	426-110*	NA	CYLINDER LINER	1098	4
	426-120*	\$34.89	CYLINDER LINER	1275	4
* Cylinder liners are used to repair damaged bores. Block is bored to accept the liner, liner is pressed into block, trimmed flush with block deck, then bored and honed to fit the piston.					
23	837-310	\$54.99	CONNECTING ROD, # 1 & 3	948	2
	837-300	\$48.99	CONNECTING ROD, # 2 & 4		2
24	322-480	\$2.89	BOLT, wrist pin		4
25	365-730	\$0.25	LOCKWASHER		4
26	837-350	NA	CONNECTING ROD, # 1 & 3	1098	2
	837-360	NA	CONNECTING ROD, # 2 & 4		2
26a	422-085	\$8.29	BUSH SET (4)		1
27	837-330	\$18.69	BOLT, connecting rod	948 & 1098	8
28	837-335†	\$1.89	LOCK TAB		4
29	837-320	\$179.99	CONNECTING ROD	1275	4
32	837-340	NA	BOLT, connecting rod		8
33	837-345	\$4.29	NUT, connecting rod		8
39	435-670	NA	FLANGE, star drive		1
40	451-442	NA	CAMSHAFT, stock, pin drive		948**
**See "Performance" color pages at the front of this catalog for more camshafts.					
41	NA	NA	CAM BEARING, single	948 (9C engine)	1
Not available. Use cam bearing set 424-980 for 1275, discard extra bearings.					
	424-975	\$16.89	CAM BEARING SET	948 (9CG) & 1098	1
	424-980	\$16.89	CAM BEARING SET	1275	1
42	327-190	\$0.99	KEY, camshaft, stock		1
	327-005	\$25.99	KEY, camshaft, 2 degree offset		1
	327-015	\$28.99	KEY, camshaft, 3 degree offset		1
	327-025	\$28.99	KEY, camshaft, 4 degree offset		1
	327-035	\$30.99	KEY, camshaft, 5 degree offset		1
43	460-475	\$10.49	PLATE, cam locating		1
44	460-525†	\$29.99	CAM SPROCKET, single row †	948 & 1098	1
† This does not use the original tensioner rings.					
	833-430	\$18.89	CAM SPROCKET, double row	1275	1
45	460-550†	\$0.89	LOCK PLATE		1
46	311-500	\$2.19	NUT		1

## 948 - 1098 - 1275 - Internal Engine

47	460-596	\$32.99	TIMING CHAIN, heavy duty upgrade	948 & 1098 single row chains	1	
	460-595	\$5.99	TIMING CHAIN, single row		1	
	460-591	\$43.99	TIMING CHAIN, heavy duty upgrade		1275 double row chains	1
	114-077	\$13.89	TIMING CHAIN, orig. manufacturer			1
	460-590	\$8.49	TIMING CHAIN, aftermarket			1
48	460-495	\$2.79	TENSIONER RING	948 & 1098	2	
49	460-640	\$76.99	SPINDLE, distributor drive		1	
50	322-890	NA	BOLT, main bearing cap	948, 1098 (10CG)	6	
		NA	BOLT, main bearing cap	early 12CC, early 12CD	6	
	322-895	\$3.59	BOLT, main bearing cap	from late 12CC/GD - on	6	
51	114-015†	\$0.99	LOCK TAB	948, 1098 (10CG)	6	
	114-015†	\$0.99	LOCK TAB	early 12CC, early 12CD	6	
52	NA	NA	COLLAR	{ 948, 1098 (10CG) early 12CC, early 12CD	6	
	114-027	\$9.99	COLLAR	from late 12CC/GD - on	6	
53	NA	NA	STUD, main bearing cap	1098 (10CC)	6	
54	021-634	\$0.69	NUT (all metal, self-locking)		6	
55	320-990	\$0.69	BOLT, oil pick-up		4	
56	462-385	\$0.19	LOCKWASHER		4	
57	114-003	\$29.99	OIL SUCTION PIPE & BRACKET	1098, 1275	1	

### Heavy Duty Bolt and Stud Kits

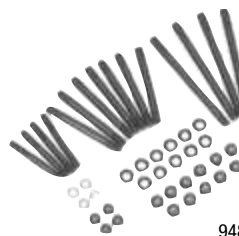

These premium quality fastener kits are perfect for the racer, road warrior, or anyone who wants added insurance against mechanical failure. The head stud kit includes 11 studs. While factory engines used 9, some engines have been modified to use two more. Head studs and main cap studs are rated at 190,000 p.s.i., rod bolts at 180,000 p.s.i. Main bearing cap stud kit replaces original bolts.

948,1098,1275 Head Stud Kit	<b>322-998</b>	<b>\$184.99</b>
948,1098,1275 Main Bearing Cap Stud Kit	<b>322-888</b>	<b>\$73.99</b>
1275 Connecting Rod Bolt Kit	<b>322-838</b>	<b>\$162.99</b>

### Engine Locktab Sets

Save the hassle of ordering all the separate locktabs on your engine with these sets, which include all locktabs in the listings to the left marked †.

948-1098 Locktab Set	<b>328-635</b>	<b>\$31.99</b>
1275 Locktab Set	<b>328-620</b>	<b>\$31.99</b>



### Vernier Cam Sprocket Kit



If you are serious about making your engine run "just right", this is one upgrade you should be sure to install. This adjustable cam sprocket enables you to time your cam perfectly to factory specifications, or to change the factory cam timing on seriously modified engines. Kit includes adjustable cam sprocket, duplex crank sprocket, and duplex chain.

**460-385 \$164.99**

### Aluminum Flywheels

Improved throttle response is a main benefit of using this high strength but light weight steel-faced alloy flywheel.

948	460-505	<b>\$459.99</b>
1275	461-005	<b>\$459.99</b>



### Speedi-Sleeve

Timing Cover Seal. (use on illustration #4)

When a new seal cannot compensate for excessive damage, this ultra-thin sleeve provides a "new" sealable surface. Instructions and installation tool are included.

**520-515 \$53.99**



### Identifying the BMC Engine

The BMC "A" series engine is of venerable lineage. Adapted from the Austin A35 it appeared in the Austin-Healey Sprite as the "948", then went through minor revisions as the "1098". A major revision, the "1275", the strongest engine of the series, appeared in late 1966.

A "950" was cast in the left side of the "948" block. The "1100" (1098) and "1275" had metal tags riveted to the left side of the block just behind the bearer plate. All of these engines had an aluminum tag riveted to the top of the block on the right front. The first number designates the series: 9 = 948cc; 10 = 1098cc; 12 = 1275cc. If the tags have been removed, measuring the piston bore and main cap journals will reveal its origination. The "948" came with a stamped steel backplate and the 1275 is easily identified by its lack of tappet covers.

948	9C, 9CG	1098	10CG 1-3/4" main bearings
1275	12CC, 12CD, 12CE*, 12CF*, 12CG* 12CH*, 12CJ*, 12CK*, 12V (* = not USA)		10CC 2" main bearings

**LOCAL & OVERSEAS: 805-681-3400**  
**FAX: 805-692-2525** [www.mossmotors.com](http://www.mossmotors.com)

**MOSS**

# Cylinder Head 948 - 1098 - 1275

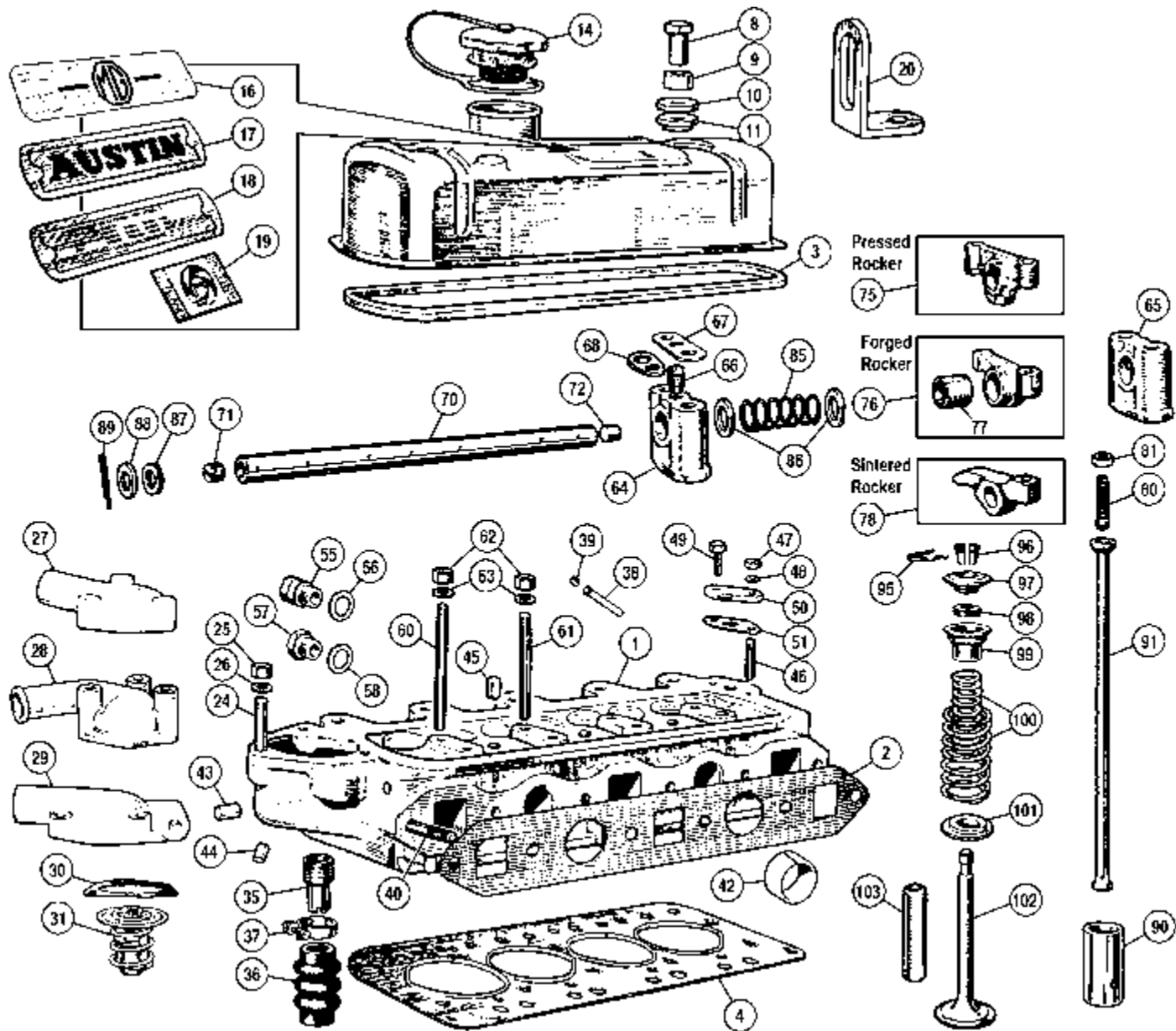

No.	Part No.	Price (each)	Description	Application	Qty. Req.	
1	451-875	\$1399.00	ALLOY CYLINDER HEAD, new	948 - 1098cc 1275	1	
	296-641	\$26.99	HEAD GASKET SET, Payen	948 & 1098cc	1	
	296-642*	\$23.99	HEAD GASKET SET *		1	
	296-653	\$35.99	HEAD GASKET SET, Payen (with copper head gasket)		1	
	296-651	\$42.99	HEAD GASKET SET, Payen (with composition head gasket)		1	
	296-654*	\$23.79	HEAD GASKET SET, w/ copper head gasket *	1275	1	
	296-652*	\$14.29	HEAD GASKET SET, w/ composition gasket *		1	
2	296-630	\$1.89	MANIFOLD GASKET		1	
3	296-005	\$1.29	GASKET, valve cover, stock type		1	
	296-006	\$18.99	GASKET, valve cover, silicone (not in gasket sets)		1	
4	694-536	\$16.49	HEAD GASKET, copper, Payen	948 - 1098	1	
	117-120*	\$14.99	HEAD GASKET, upgraded/competition *		1	
	694-535*	\$7.89	HEAD GASKET, composition*		1	
	694-526	\$21.99	HEAD GASKET, composition, Payen		1	
	694-525*	\$7.79	HEAD GASKET, composition*		(not alloy head)	1
	694-527	\$19.49	HEAD GASKET, composition, Payen		1275 alloy head	1
	* Products from various aftermarket manufacturers supplied.					
8	460-110	\$2.39	CAP NUT, valve cover		2	
9	460-115	\$1.39	SPACER		2	
10	460-130	\$0.69	WASHER, cupped		2	
11	460-120	\$0.39	BUSH, rubber		2	
14	460-100	\$10.19	CAP, metal, w/ cable	948 engines	1	
	460-145	\$12.39	CAP, chromed, without cable	all vented applications	1	

No.	Part No.	Price (each)	Description	Application	Qty. Req.
	460-125	\$4.89	CAP, plastic (non-vented)	1098 (10CG engines)	1
	460-102	NA	CAP, plastic (vented), OE type	1098 (10CC engines & 1275 (12CC, CD, CE)	1
	460-105	\$5.99	CAP, plastic (vented), replacement		1
	460-125	\$4.89	CAP, plastic (non-vented)	1275 CJ eng. (1970-on)	1
16	408-800	\$3.89	VALVE COVER PLATE, MG	aluminum plates	1
17	408-800	\$4.49	VALVE COVER PLATE, Austin		1
18	408-810	\$4.39	VALVE COVER PLATE, patent		1
	458-765	\$0.39	RIVET for aluminum plates		A/R
	215-620	\$2.79	VALVE COVER PLATE, MG	self adhesive mylar	1
	031-232	\$2.79	VALVE COVER PLATE, Austin		1
	215-625	\$2.79	VALVE COVER PLATE, patent		1
	19	215-660	\$1.99		STICKER, "British Leyland"
20	386-745	\$5.79	LIFTING BRACKET		2
24	328-605	\$1.49	STUD, thermostat housing	for housings #27 & 29	3
	328-606	\$0.89	STUD, thermostat housing	for housing #28	3
25	310-140	\$0.24	NUT		3
26	365-720	\$0.29	WASHER		3
27	460-890	\$29.99	ELBOW, water outlet	948 (flat top)	1
	460-855	\$39.99	ELBOW, water outlet	1098 - 1275 vert. rad.	1
28	460-895	NA	ELBOW, water outlet	1275 cross-flow rad.	1
29	460-885	NA	ELBOW, water outlet	12CD, 12CJ & 12V	1

MOSS

MOSS MOTORS, LTD.  
TOLL-FREE ORDERS

1-800-667-7872

No.	Part No.	Price (each)	Description	Application	Qty. Req.
30	296-380	NA	GASKET, thermostat, stock type cork		1
	296-381	\$1.99	GASKET, thermostat, high strength "Klingersil" <small>MORE INFO ONLINE</small>		1
31	434-180	\$4.49	THERMOSTAT, 160°, hot climates	} will not fit original } 948 water elbows. } Will fit Moss 460-890.	1
	434-189	\$4.49	THERMOSTAT, 180°, normal		1
	434-190	\$4.69	THERMOSTAT, 192°, cold climates		1
35	434-535	\$19.99	ADAPTOR, bypass (also used on early orig. water pumps)		2/1
36	434-530*	\$6.79	HOSE, bypass (with 2 original type type hose clamps)		1
37	262-200	\$1.89	CLAMP, bypass hose	original band type	2
* These hoses are ribbed as original for easy installation.					
38		NA	AIR INJECTION TUBE	1275	4
39	052-242	\$1.29	PLUG, air injection port (when air injection disabled)		4
40	328-900	\$2.19	STUD, manifold		6
	310-140	\$0.24	NUT, manifold stud, steel	} alternatives	6
	311-540	\$0.59	NUT, manifold stud, brass		6
	324-365	\$0.89	WASHER, inlet manifold		4
42	372-371	\$2.19	FERRULE, inlet manifold locating	from 10CG 18628 thru 10CC	2
43	114-000	NA	PLUG, oil hole at front of head		1
	114-109	\$10.99	PLUG, water holes, at ends of head	1275	2
44	114-110	NA	PLUG, water holes, bottom of head		3
45	114-105	\$5.79	PLUG, oil holes, ends & top of head	(as fitted)	5
46	117-010	\$1.69	STUD, heater valve	} alternative to no. 49	2
47	310-760	\$0.39	NUT		2
48	324-020	\$0.20	LOCKWASHER		2
49	322-230	\$0.19	BOLT (alternative to nos. 46, 47, 48)		2
50	360-215	\$8.49	BLANKING PLATE	when heater not fitted	1
51	296-455	\$0.69	GASKET		1
55	361-065	\$7.49	ADAPTER, temperature gauge	} 1968-'74 (crossflow radiator)	1
56	324-805	\$1.99	WASHER, temp. gauge adapter		1
57	379-362	\$8.99	BLANKING PLUG	} when using late head on 1	1
58	324-145	\$0.29	WASHER, blanking plug	} pre-1968 car	1
60	329-700	\$3.89	STUD, pedestal & valve cover long (outer)		2
61	328-745	\$1.39	STUD, pedestal, short (inner)	948 - 1098	2
	329-710	\$3.99	STUD, pedestal, short (inner)	1275	2
62	310-290	\$0.69	NUT for pedestal studs		4
63	365-730	\$0.25	LOCKWASHER		4
64	114-136	NA	PEDESTAL, tapped	} see note	1
65	114-133	NA	PEDESTAL, oil hole		3

Note: Engines through early 1275 production had the front pedestal tapped for the rocker shaft locating screw, and with an oil hole. Later 1275 engines had a tapped pedestal with no oil hole in the second position, with the front pedestal having a drilled oil hole. The "oil hole" pedestals were also used in the two rear positions. Our pedestals are of the later type. To use the tapped pedestal in the front position on early cars, drill a 1/8" hole centered in the dimple on the bottom of the pedestal, into the shaft bore. The "oil hole" pedestals may be used as is in the other positions.

66	460-270	\$1.79	SCREW, rocker shaft locating		1
67	433-880	NA	PLATE, rocker shaft pedestal	see note *	4/1
* Note: Use one no. 68 (460-280) on front pedestal to retain screw no. 62.					
68	460-280	\$3.39	PLATE, screw retaining		1
70	451-455	\$17.49	SHAFT, rocker arm		1
	114-124	\$30.99	SHAFT, rocker arm, Tuftrided (hardened against wear)		1
71	328-080	NA	PLUG, threaded		1
72	328-290	\$15.99	PLUG, pressed in		1
75	†	NA	ROCKER ARM, pressed †	use no. 76 or 78	8
76	433-840†	\$15.89	ROCKER ARM, forged †	1275, replacement for all 8	8
These are stock late 1275 rockers, and include adjuster & nut.					
77	330-495	\$1.59	BUSH	all forged rocker arms	8
Bushes must have oil holes drilled after installation in rocker arm, and must be reamed to fit the rocker shaft.					
78	433-850†	\$24.99	ROCKER ARM, sintered, replacement †		8
These sintered rocker arms are slightly porous and are self-lubricating once soaked in oil. They are not bushed. Should be used with Thackery washer No. 88.					
80	433-860	\$11.79	ADJUSTER (28 t.p.i.)	early forged & stamped rockers †	8
	460-260	\$1.09	ADJUSTER (24 t.p.i.)	late forged & sintered rockers †	8
81	433-870	\$2.29	NUT, adjuster locking	early forged & stamped rockers †	8
	310-150	\$0.39	NUT, adjuster locking	late forged & sintered rockers †	8

† Note: Early 948 had forged rockers (not identical to late 1275 forged rockers), followed by pressed steel rockers into 1275 production. Forged rockers 433-840 were originally supplied on many 1275 engines. Sintered rockers are stock for post-Sprite/Midget A-Series engines produced for other cars.

No.	Part No.	Price (each)	Description	Application	Qty. Req.
85	114-134	\$2.99	SPRING		3
86	379-363	\$1.49	SPACER (at ends of springs)	1275 only	6
87	329-860	\$0.79	WASHER, Thackery	948-1098	2
Use also on 1275 when using sintered rocker arms 433-850.					
88	114-135	\$0.99	WASHER (ends of shaft)		2
89	325-330	\$0.19	COTTER PIN		2
90	460-612	\$39.99	TAPPET SET, AE brand		1
	460-604	\$199.99	TAPPET SET		1
(8 specially selected tappets properly sized, hardened to 54-58 HRC, crowned, etched, & micro-polished, with lube)					
	460-601	\$199.99	TAPPET SET, APT brand		1
(60+ HRC, crowned, phosphated, oil hole. Suitable for high lift cams and higher rpm.)					
	460-608	NA	TAPPET SET, lightened, with oil hole		1
(suitable for high lift cams and higher rpm.)					
91	460-625	\$3.99	PUSH ROD	948 & 1098	8
	460-635	\$3.89	PUSH ROD	1275	8
95	326-165	NA	SPRING CLIP (not required)	} 948 & 1098	8
96	460-485	\$10.99	VALVE COTTER		16
	460-535	\$2.09	VALVE COTTER	1275	16
97	460-552	\$3.99	COLLAR, valve retainer	948-1098	8
	460-556	\$7.79	COLLAR, valve retainer	1275	8
98	297-650	\$0.29	SEAL, valve stem, o-ring	948 & 1098	8
	297-635	\$0.49	SEAL, valve stem, umbrella	1275 intake only	4
99		NA	SHROUD	early 948	8
(Shroud not required when using o-ring valve stem seal)					
100	114-106	\$2.99	VALVE SPRING, single	early 948	8
	423-460	\$26.89	VALVE SPRING SET, dual springs	late 948, all 1098	1
	423-470	\$25.89	VALVE SPRING SET	1275	1
101	460-565	\$1.89	CUP	double springs only	8
102	423-195	\$6.79	INTAKE VALVE	} 948 (9C engine) } Bugeye	4
			1.094" head dia.*		
	423-175	\$5.89	INTAKE VALVE	} 948 (9CG) & 1098 } to 10CG 14877	4
			1.156" head dia.*		
	423-185	\$5.89	INTAKE VALVE	} 1098 from } 10CG 14878 & 10CC	4
			1.215" head dia.*		
	423-190	\$4.79	INTAKE VALVE	} 1275	4
			1.313" head dia.*		
	423-320	\$6.49	EXHAUST VALVE, stainless steel	} 948 & 1098	4
			1.000" head dia.*		
	423-325	NA	EXHAUST VALVE, O/S	} 1275	4
			1.098" head dia.*		
	423-330	\$6.99	EXHAUST VALVE, stainless steel	} 1275	4
			1.156" head dia.*		
	423-335	\$18.89	EXHAUST VALVE, stainless steel/stellite tip		4
* Valve head diameters may vary by .005" or more due to manufacturing tolerances.					
103	423-286	\$2.79	VALVE GUIDE, intake & exhaust	948 (9C - Bugeye)	8
	423-275	\$1.89	VALVE GUIDE, intake & exhaust	} 948 (9CG) & 1098	8
	423-290	\$7.29	VALVE GUIDE, manganese-bronze		8
	423-285	\$2.79	VALVE GUIDE, intake & exhaust	} 1275	8
	423-295	\$6.99	VALVE GUIDE, manganese-bronze		8

### Competition Gaskets

Highly recommended for use with high compression pistons and modified heads, the copper and asbestos head gasket is made to original British Leyland specifications. The special manifold gasket has enlarged holes to match inlet and exhaust ports on modified cylinder heads.



**Competition Head Gasket (1275)** 694-555 \$17.99  
**Competition Manifold Gasket (948 - 1275)** 296-645 \$11.99

# Midget 1500 Engine

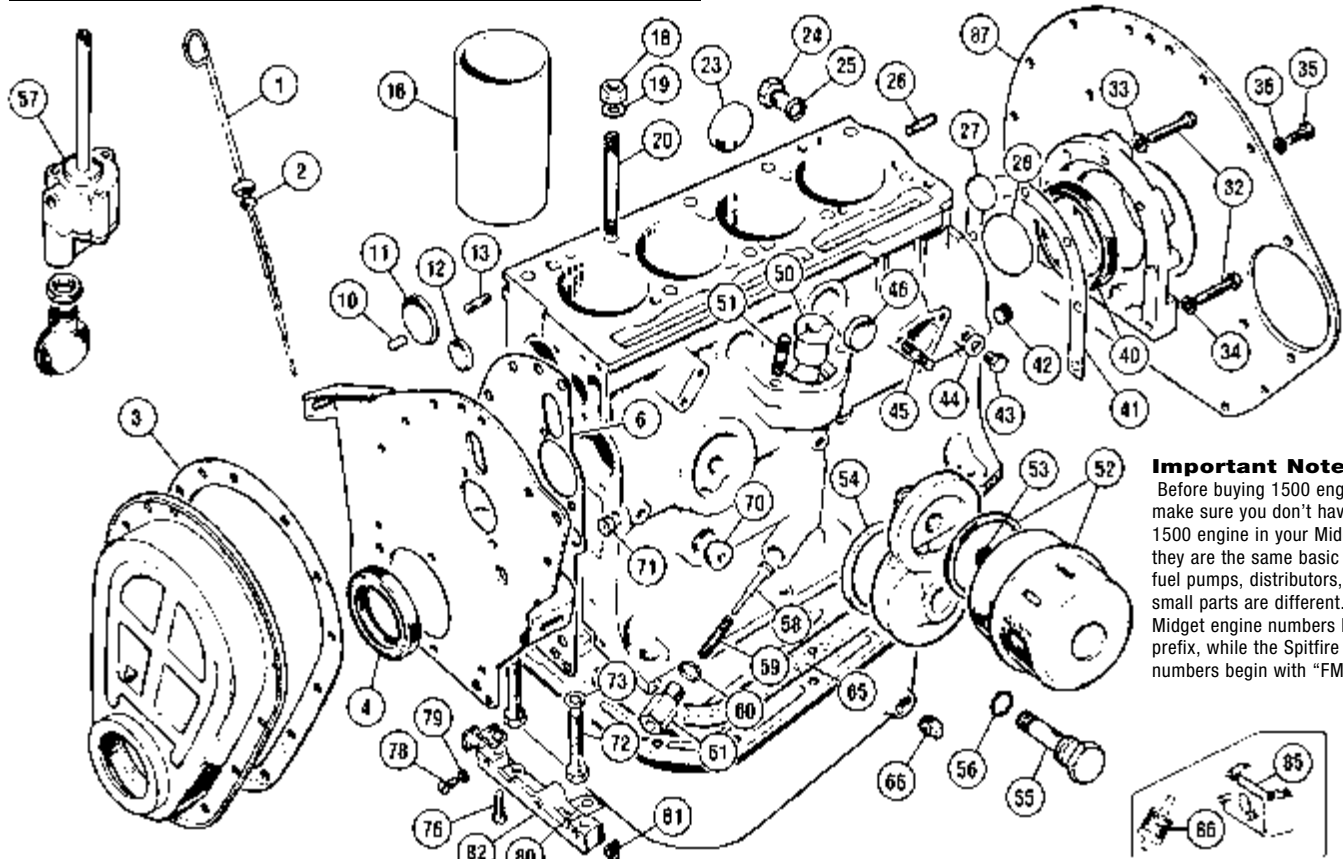

**Important Note:**  
Before buying 1500 engine parts, make sure you don't have a Spitfire 1500 engine in your Midget. While they are the same basic engines, fuel pumps, distributors, and some small parts are different. The real Midget engine numbers have a "FP" prefix, while the Spitfire engine numbers begin with "FM".

No.	Part No.	Price (each)	Description	Application	Qty. Req.
	694-151	\$21.99	<b>GASKET SET, lower engine, "Payen" brand</b>		1
	694-152	\$6.99	<b>GASKET SET, lower engine</b> (various manufacturers)		1
	694-143	\$67.99	<b>HEAD GASKET SET, "Payen" brand</b>		1
	694-144	\$36.99	<b>HEAD GASKET SET</b> (various manufacturers)		1
1	451-205	NA	DIPSTICK		1
2	697-020	\$0.69	SEAL, felt		1
3	697-115	\$1.59	GASKET, timing cover		1
4	520-430	\$4.49	OIL SEAL, timing cover		1
6	695-105	\$1.39	GASKET, front engine plate		1
10	325-215	\$0.89	DOWEL PIN		2
11	328-205	\$0.89	CORE PLUG, steel, large		1
	328-207	\$3.29	CORE PLUG, brass, large		1
12	319-015	\$0.89	CORE PLUG, steel, small		1
	319-016	\$3.69	CORE PLUG, brass, small		1
13	328-654	\$2.29	STUD		1
16	426-130	\$34.89	LINER, cylinder	(requires machining)	4
18	310-045	\$0.79	NUT, head stud		10
19	324-860	\$0.19	WASHER, head stud		10
20	329-615	\$14.79	STUD, cylinder head		10
23	328-205	\$0.89	CORE PLUG		3
24	328-445	\$9.99	PLUG, drain		1
25	324-671	\$0.89	WASHER for plug		1
26	328-900	\$2.19	STUD		3
27	328-215	\$0.79	CORE PLUG, steel, small		1
	328-216	\$3.19	CORE PLUG, brass, small		1
28	328-375	\$0.79	CORE PLUG, steel, large		1
32	320-695	\$0.69	BOLT, seal housing to block		7
33	NA		WASHER, copper		1
34	365-730	\$0.25	LOCKWASHER		6
35	322-040	\$0.49	BOLT		7
36	365-730	\$0.25	LOCKWASHER		7
40	520-320	\$2.79	OIL SEAL, rear		1
41	697-485	\$0.39	GASKET, seal housing to block		1
42	328-245	\$4.29	PLUG, oil gallery, rear		1
43	322-345	\$0.49	PLUG, oil gallery, side		4
44	NA		WASHER, copper		4
45	328-654	\$2.29	STUD, fuel pump mounting		2
46	328-215	\$0.79	CORE PLUG, steel		2
	328-216	\$3.19	CORE PLUG, brass		2
50	836-135	\$82.99	BUSH, distributor/oil pump drive		1
51	328-654	\$2.29	STUD, distributor mounting		2
52	950-525	\$5.79	OIL FILTER, with sealing ring, Classic Gold brand		1
53	833-455	\$4.99	ADAPTOR, oil filter to filter head		1

No.	Part No.	Price (each)	Description	Application	Qty. Req.
54	520-400	\$0.99	SEAL, filter head to block		1
55	NA		BOLT, filter head		1
56	466-515	\$0.59	"O" RING		1
57	836-125	\$83.99	OIL PUMP with screen		1
58	836-545	\$3.89	PISTON, oil pressure relief valve		1
59	329-295	\$4.49	SPRING		1
60	315-005	\$0.89	WASHER, copper		1
61	328-065	\$11.89	HOUSING, oil pressure relief valve		1
65	694-160	\$1.59	GASKET, oil pan		1
66	328-340	\$1.19	PLUG, oil drain		1
	328-356	\$7.99	PLUG, oil drain, magnetic	(option)	1
	328-341	\$39.99	DRAIN TAP	(option)	1
70	328-425	\$2.39	PLUG		1
71	328-245	\$4.29	PLUG, oil gallery		1
72	266-580	\$1.39	BOLT, main bearing cap		6
73	324-250	\$0.19	LOCKWASHER		6
76	323-015	\$1.79	SCREW		2
78	320-815	\$2.39	SCREW		2
79	365-730	\$0.25	LOCKWASHER		2
80	697-490	\$0.59	GASKET, front sealing block		2
81	697-495	\$1.79	PACKING PIECE, wood		2
82	837-150	\$37.99	SEALING BLOCK, front		1
85	810-120	\$18.79	MOUNT, engine		2
86	810-140	\$2.69	MOUNT, transmission		2
87	832-545	\$99.99	BEARER PLATE, rear	aluminum alloy repl.	1

## Core Plug Set

All core plugs for the engine block and cylinder head.

328-278	\$8.99	CORE PLUG SET, steel	1
---------	--------	----------------------	---



## Oil Cooler Installation Kit

This kit allows fitment of a 13-row oil cooler on the Midget 1500. Uses stock filter and adaptor. Oil cooler and filter are not included. May require relocation of air pump hose.

Installation Kit	235-922	\$179.99
13-row Cooler	235-925	\$52.99



**MOSS MOTORS, LTD.**  
TOLL-FREE ORDERS

**1-800-667-7872**

# Midget 1500 Engine

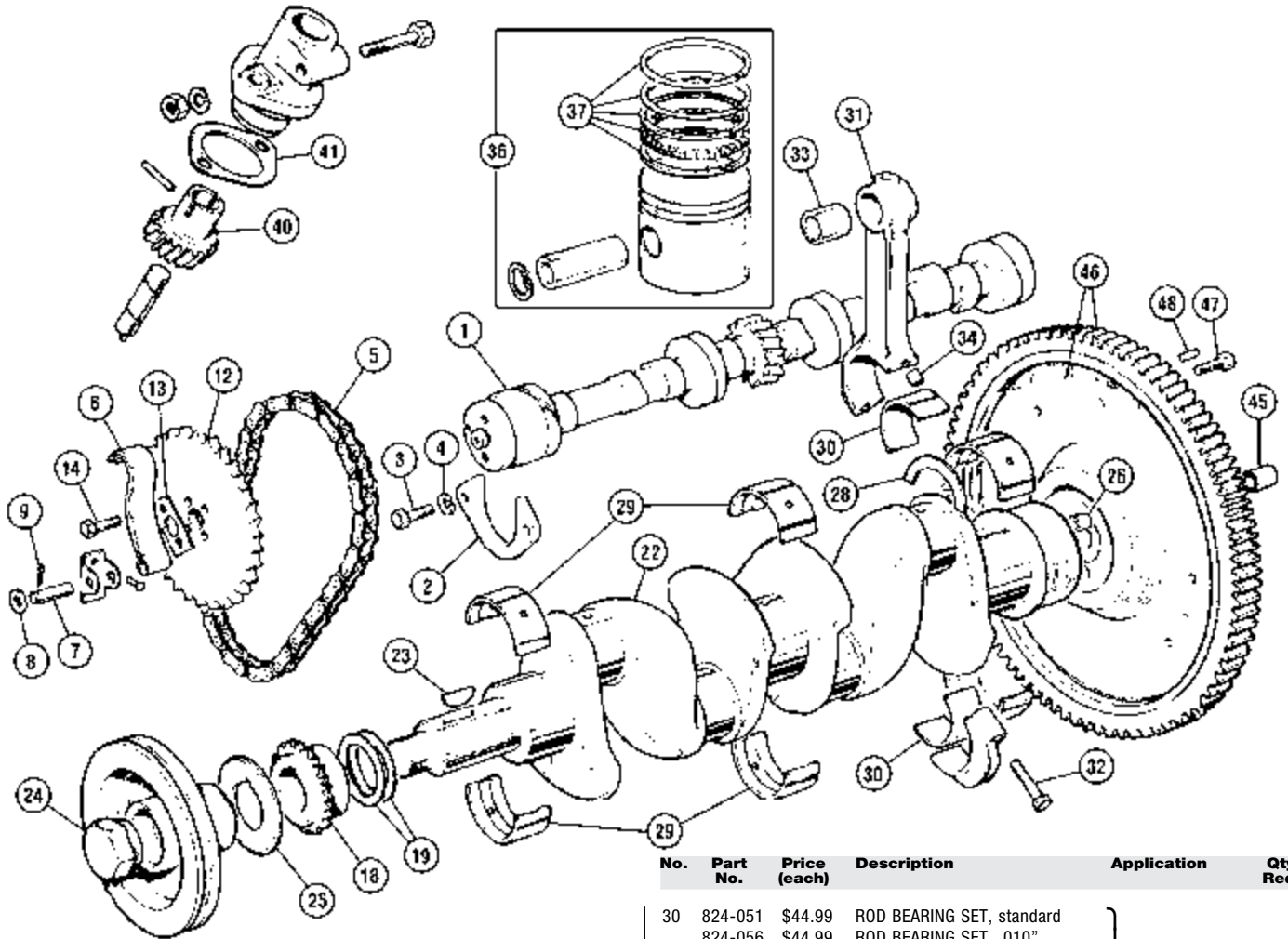

No.	Part No.	Price (each)	Description	Application	Qty. Req.
1	851-330	\$199.99	CAMSHAFT		1
2	838-035	\$27.99	RETAINER, camshaft		1
3	322-540	\$0.69	BOLT for retainer		2
4	365-730	\$0.25	LOCKWASHER		2
5	832-111	\$38.99	TIMING CHAIN, heavy duty upgrade <a href="#">MORE INFO ONLINE</a>		1
	832-110	\$6.89	TIMING CHAIN		1
6	832-260	\$4.89	TENSIONER, timing chain		1
7	832-265	\$4.79	PIN, tensioner pivot		1
8	324-870	\$0.49	WASHER, plain		1
9	325-475	\$0.29	COTTER PIN		1
12	838-205	\$23.89	SPROCKET, camshaft		1
13	838-025	\$0.49	LOCKPLATE, cam sprocket		1
14	322-395	\$2.89	BOLT, sproket to camshaft		2
18	837-105	\$24.99	SPROCKET, crankshaft		1
19	837-025	\$1.39	SHIM, .004"	A/R	1
	837-035	\$1.39	SHIM, .006"	A/R	1
22	851-350	NA	CRANKSHAFT		1
23	327-220	\$17.99	KEY		1
24	322-910	\$36.99	NUT, crankshaft		1
25	837-055	\$7.79	OIL DEFLECTOR		1
26	325-190	\$8.99	DOWEL, flywheel to crankshaft		1
28	828-030	\$4.89	THRUST WASHER SET, standard		1
	828-035	\$4.89	THRUST WASHER SET, .005"		1
	828-040	\$8.39	THRUST WASHER SET, .015"		1
29	822-041	\$39.99	MAIN BEARING SET, standard	} Tri-metal	1
	822-051	\$39.99	MAIN BEARING SET, .010"		1
	822-061	\$39.99	MAIN BEARING SET, .020"		1
	822-071	\$39.99	MAIN BEARING SET, .030"		1
	822-040	\$23.89	MAIN BEARING SET, standard	} Bi-metal	1
	822-050	\$23.89	MAIN BEARING SET, .010"		1
	822-060	\$23.89	MAIN BEARING SET, .020"		1
	822-070	\$23.89	MAIN BEARING SET, .030"		1
	822-080	\$23.89	MAIN BEARING SET, .040"		1

No.	Part No.	Price (each)	Description	Application	Qty. Req.
30	824-051	\$44.99	ROD BEARING SET, standard	} Tri-metal	1
	824-056	\$44.99	ROD BEARING SET, .010"		1
	824-061	\$44.99	ROD BEARING SET, .020"		1
	824-066	\$44.99	ROD BEARING SET, .030"		1
	824-050	\$27.99	ROD BEARING SET, standard		1
	824-055	\$27.99	ROD BEARING SET, .010"		1
	824-060	\$27.99	ROD BEARING SET, .020"	} Bi-metal	1
	824-065	\$27.99	ROD BEARING SET, .030"		1
	824-070	\$27.99	ROD BEARING SET, .040"		1
31	837-740	\$95.99	CONNECTING ROD, reconditioned		4
32	320-455	\$4.99	BOLT, connecting rod		8
33	829-030	\$2.29	BUSH, wrist pin		4
34	837-745	NA	TUBE, locating		8
36	814-451	\$199.99	PISTON SET, std., aftermarket	} 9:1 CR, thru 1976 except CA	1
	814-456	\$199.99	PISTON SET, .020", aftermarket		1
	814-461	\$199.99	PISTON SET, .030", aftermarket		1
	814-466	\$199.99	PISTON SET, .040", aftermarket		1
	814-470	\$199.99	PISTON SET, std., aftermarket	} 7.5:1 CR CA all years Federal 1977-on	1
	814-475	\$199.99	PISTON SET, .020", aftermarket		1
	814-480	\$199.99	PISTON SET, .030", aftermarket		1
	814-485	NA	PISTON SET, .040", aftermarket		1
37	817-650	\$55.79	PISTON RING SET, standard	} Hastings brand	1
	817-655	\$55.79	PISTON RING SET, .020"		1
	817-660	\$55.79	PISTON RING SET, .030"		1
	817-665	\$55.79	PISTON RING SET, .040"		1
40	836-640	NA	GEAR, oil pump & distributor drive		1
41	697-145	\$0.79	GASKET, .006"		A/R
45	330-510	\$3.99	PILOT BUSHING		1
46	460-678	\$459.99	FLYWHEEL, aluminum		1
	590-030	\$18.89	RING GEAR		1
47	320-790	\$4.99	BOLT, flywheel to crankshaft		4
48	325-340	\$1.29	DOWEL, clutch locating		3

## Speedi-Sleeve



Timing Cover Seal. For use on Crank Pulley

When a new seal cannot compensate for excessive damage, this ultra-thin sleeve provides a "new" sealable surface. Instructions and installation tool are included.

520-510 \$61.99

LOCAL & OVERSEAS: 805-681-3400  
FAX: 805-692-2525 www.mossmotors.com



# Midget 1500 Cylinder Head

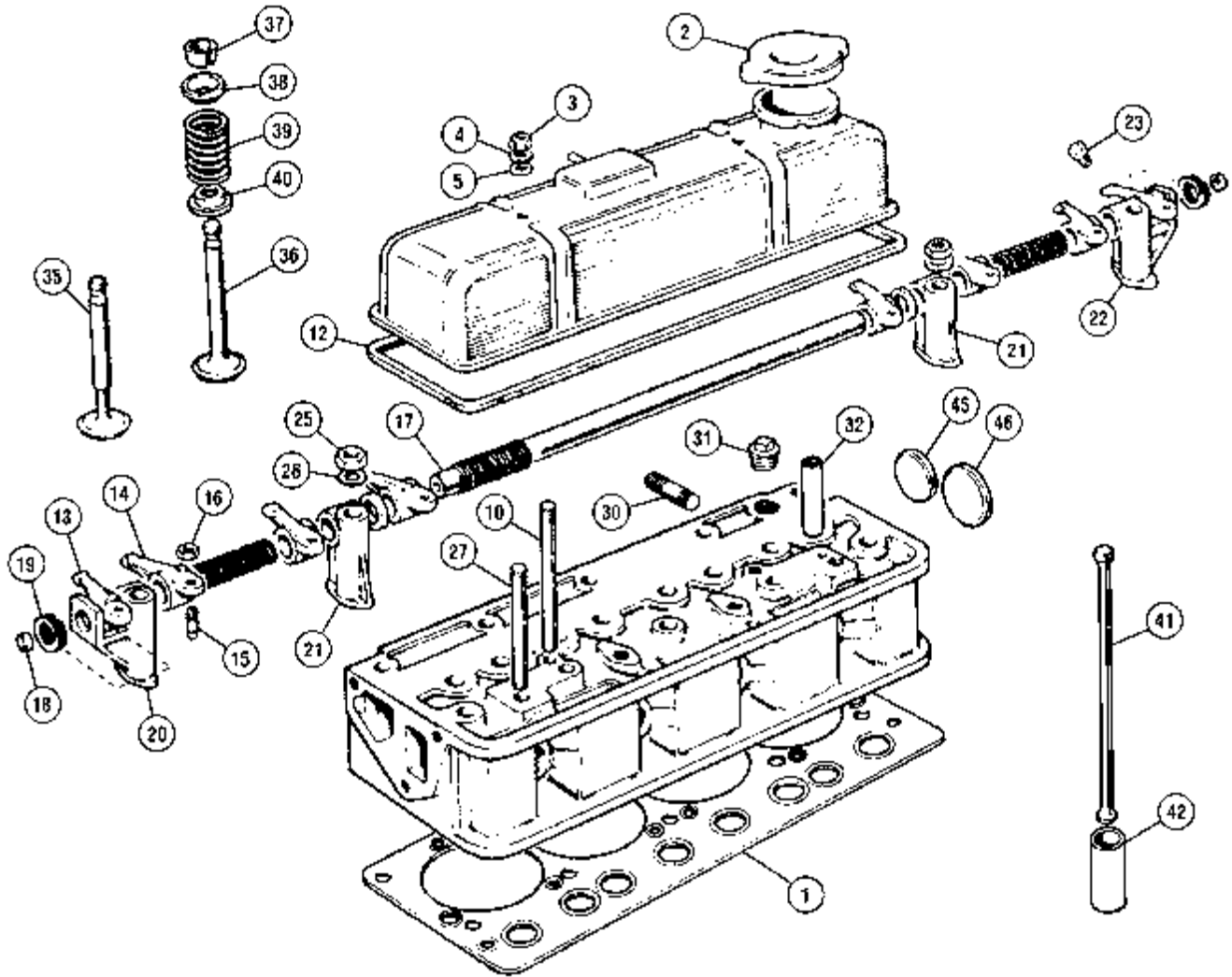

No.	Part No.	Price (each)	Description	Application	Qty. Req.
	694-143	\$67.99	HEAD GASKET SET, "Payen" brand		1
	694-144	\$36.99	HEAD GASKET SET (various manufacturers)		1
1	694-110	\$19.99	HEAD GASKET, "Payen" brand		1
2	834-765	NA	CAP, oil filler		1
	780-126	\$5.99	CAP, oil filler, replacement		1

3	310-105	\$0.39	NUT, valve cover	} thru 1976	2
4	365-720	\$0.29	WASHER, plain		2
5	324-680	\$0.29	WASHER, fiber		2
	072-019	\$3.89	CAP NUT	} from 1977-on	2
	072-020	\$2.89	WASHER		2
	071-092	\$0.69	"O" RING		2

10	328-675	\$2.89	STUD, valve cover (4-1/8" long)	thru 1976	2
	313-020	\$3.89	STUD, valve cover (3-5/16" long)	from 1977-on	2
12	694-100	\$1.99	GASKET, valve cover, stock type		1
	694-101	\$19.99	GASKET, valve cover, silicone		1

13	839-110*	\$10.89	ROCKER ARM, stock	} #1,3,5,7	4
	839-115*	\$16.99	ROCKER ARM, upgraded		4

14	839-120*	\$10.89	ROCKER ARM, stock	} #2,4,6,8	4
	839-125*	\$16.99	ROCKER ARM, upgraded		4

\*Note: Stock rocker arms were not bushed. Upgraded rocker arms are checked for correct hardness and are fitted with bushes which must be honed to 0.002" clearance on the rocker shaft. Instructions are included.

15	839-030	\$4.99	ADJUSTER, valve		8
16	310-150	\$0.39	NUT for adjuster		8
17	851-320	\$24.99	ROCKER SHAFT		1
18	839-100	\$3.49	END PLUG		2
19	329-860	\$0.79	SPRING, front & rear pedestals		2
20	831-585	NA	PEDESTAL, front		1
21	831-590	NA	PEDESTAL, intermediate		2

No.	Part No.	Price (each)	Description	Application	Qty. Req.
22	831-595	\$26.99	PEDESTAL, rear		1
23	323-215	\$10.99	SCREW		1
25	310-050	\$0.59	NUT, rocker shaft pedestal		4
26	324-860	\$0.19	WASHER		4
27	328-665	\$3.89	STUD, rocker shaft pedestal		4
30	328-660	\$1.59	STUD, exhaust manifold (1-3/8" long)		2
	328-650	\$2.29	STUD, inlet & exhaust manifolds (1-7/8" long)		6
31	328-340	\$1.19	PLUG, threaded		1
32	830-000	\$1.69	VALVE GUIDE, inlet & exhaust, stock type		8
	830-015	\$7.39	VALVE GUIDE, inlet & exhaust, manganese bronze		8
35	821-250	\$7.69	VALVE, inlet		4
36	821-260	\$5.99	VALVE, exhaust, stainless steel		4
37	831-530	\$1.69	SPLIT COTTER, valve retaining		16
38	821-210	NA	COLLAR, upper, stock		8
	839-150	\$4.79	COLLAR, upper, aluminum alloy	use in sets of 8 only	8
39	821-270	\$23.99	VALVE SPRING SET, double springs		1
40	821-240	NA	COLLAR, lower		8
41	838-530	\$2.89	PUSHROD		8
42	838-306	\$169.99	TAPPET SET, APT brand		1
			(60+ HRC heat treated chilled cast iron, with oil hole)		
	838-300	\$4.99	TAPPET, stock type		8
45	328-215	\$0.79	CORE PLUG, steel, small		1
	328-216	\$3.19	CORE PLUG, brass, small		1
46	328-235	\$0.99	CORE PLUG, steel, large		1
	328-236	\$3.99	CORE PLUG, brass, large		1

## Core Plug Set

All core plugs for the engine block and cylinder head.

328-278	\$8.99	CORE PLUG SET, steel	1
---------	--------	----------------------	---

MOSS

MOSS MOTORS, LTD.  
TOLL-FREE ORDERS

1-800-667-7872





### Oberg Tilt Lift

It never fails. No matter what angle you hang an engine from its sling, it will be wrong. Unfortunately, most cars require the engine to be installed in an arc. This chore is hard enough with help, but it's nearly impossible without. Tilt Lift is a product which enables you to remove or install an engine alone. Tilt Lift allows easy adjustment of an engine's lift angle through a full 90 degrees of movement. Adjustment is easy, employing your 1/2" ratchet, and the 2,000 pound capacity – with a 3:1 safety load factor – is more than enough for any modern engine/tranny combination. A positive lock ensures the engine stays put. Tilt Lift's all steel construction ensures durability,

and its small size (weighing only four pounds) makes it perfect for small work areas. The mounting cleats are adaptable to any engine. Reduce the risk of personal injury, or damage to your car with a Tilt Lift.

386-730 \$99.99



### "Ultra Slick" Engine Assembly Lube

The most critical time for dangerous wear during an engine's life is during initial start-up. Protect your rebuild (and all of those expensive parts) by using "Ultra Slick" during assembly of camshafts, lifters, engine bearings, timing components, valves & guides and rocker shaft assemblies. It's the best insurance available.

221-565 \$9.99

### Hylomar Gasket Dressing

Hylomar "M" was originally the Racing Formulation, is acetone based, stiffens slightly over time and can be used in place of a gasket between finely machined surfaces. Hylomar Advanced Formulation or "AF" is solvent-free, won't harden and is perfect for use with gaskets on parts that need to be removed regularly for service. Both are perfect for shop use, and are ethanol and fuel proof.

232-215 \$26.99 Hylomar AF, 85 gram tube  
232-220 \$21.99 Hylomar M, 80ml tube



### Engine Paint

The right paint in the right color is the only kind to use on your freshly rebuilt engine. We invested a lot of time and effort to develop the correct shade of olive green for Sprigets. One can is enough to paint a properly prepared engine. (Black is not Moss "Classic Color") Our high temperature primer is specially selected for compatibility with our engine paints.

Dark Olive Green 220-580 \$21.69  
Black (1972-'80) 220-575 \$16.99  
Primer, high temp. 220-576 \$14.99

### Magnetic Drain Plugs

Safeguard your engine! Our magnetic oil drain plug helps protect your engine by collecting metallic particles before they get fed through your oil system. Fits your gearbox, too!

948-1275 328-282 \$16.79  
Midget 1500 328-356 \$7.99



### 1275 Alloy Cylinder Head

Use unleaded fuel with confidence, and increase your engine's efficiency and performance. These light-weight (9 lbs.) high strength aluminum alloy cylinder heads run cooler, allow higher compression ratios, and have a greater than 35% increase in flow rate over stock heads. Heads come with silicon-bronze valve guides and hardened valve seats. These require 1275 valves, springs, and retainers. 12mm spark plugs are required (use part # 451-890). All of which must be purchased separately. (Quantities required in parenthesis). These heads do not have air injection ports, and therefore may not be used for street use on cars originally fitted with air pumps.

Alloy Cylinder Head	451-875	\$1399.00
Intake Valve (4 req'd.)	423-190	\$4.79
Exhaust Valve (4 req'd.)	423-335	\$18.89
Valve Spring Set (1 req'd.)	423-470	\$25.89
Valve Collar (8 req'd.)	460-556	\$7.79
Valve Cotter (16 req'd.)	460-535	\$2.09
Spark Plug (4 req'd.)	451-890	\$4.99

### Core Plug Sets

All core plugs for the engine block and cylinder head.

328-248	\$2.69	CORE PLUG SET, steel	} 948 thru (e)10CC/H3495	1
328-249	\$19.29	CORE PLUG SET, brass		1
328-253	\$3.79	CORE PLUG SET, steel	10CC/H3496, 1275	1
328-278	\$8.99	CORE PLUG SET, steel	1500	1

### Rocker Assembly Oil Feed Line

Fits Midget 1500. Provide much improved oil flow to your rocker assembly with Triumphtune's external bolt-on braided stainless steel oil line. This is an easily installed improvement that is practical for both stock and modified 1500 engines.

Complete Assembly	821-360	\$79.99
Replacement Bolt	821-375	\$21.99
Replacement Washer	821-365	\$0.99 ea.

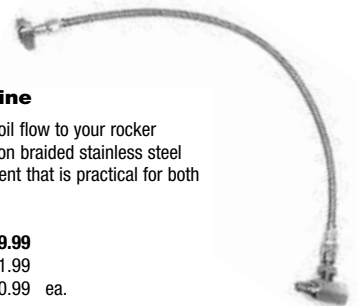

### Engine Timing Degree Wheel

To get the best performance from your engine, it's essential to ensure exact camshaft timing. Use our handy plastic degree wheel to check timing when installing a new camshaft.

384-910 \$8.99



# Cooling System - 948, 1098, 1275

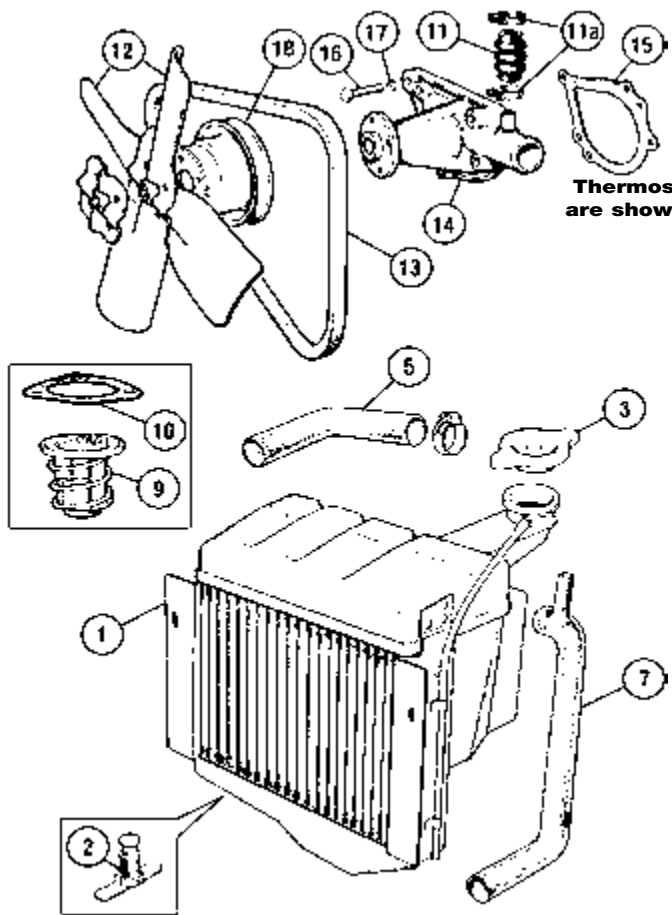

Thermostat housings are shown on page 12

No.	Part No.	Price (each)	Description	Application	Qty. Req.
<b>Vertical-Flow System 948-early 1275 (thru 1967)</b>					
1	459-730	\$249.99	RADIATOR, vertical-flow	} to AH (c)72033 } to MG (c)60440	1
2	660-020	\$10.89	DRAIN TAP		1
3	583-004	\$4.79	CAP	948 & 1098	1
5	470-370	\$4.49	HOSE, top	948 & 1098	1
	470-375	\$5.99	HOSE, top	{ 1275 to AH (c)72033 { MG (c)60440	1
7	470-380	\$22.99	HOSE, bottom	948 & 1098	1
	470-385	\$14.89	HOSE, bottom	{ 1275 to AH (c)72033 { MG (c)60440	1
9	434-180	\$4.49	THERMOSTAT, 160°, hot climates		1
	434-189	\$4.49	THERMOSTAT, 180°, normal		1
	434-190	\$4.69	THERMOSTAT, 192°, cold climates		1
10	296-380	NA	GASKET, thermostat, stock type cork		1
	296-381	\$1.99	GASKET, thermostat, high strength "Klingersil"	<a href="#">MORE INFO ONLINE</a>	1
11	434-530	\$6.79	HOSE, bypass, with original type hose clamps		1
11a	262-200	\$1.89	CLAMP, original band type		2

Check the bypass hose between the cylinder head and the water pump frequently. It is easy to mistake a leaky bypass for a faulty water pump as the leak in both cases will run down the side of the pump. Replace the bypass hose when replacing head gaskets or water pump.

12	434-550	\$26.89	FAN BLADE, sold individually		2
13	460-990	\$4.59	FAN BELT	948	1
	460-875	\$4.29	FAN BELT	1098 & 1275 thru 1967	1
14	434-540	\$22.99	WATER PUMP	948 thru 1275 (e)12CD/H1745	1
			(May use later pump for uprated flow)		
	434-545	\$21.49	WATER PUMP	1275 from (e)12CD/H1746	1
15	296-620	\$0.79	GASKET, water pump		1
16	322-105	\$0.99	BOLT, long		2
	191-915	\$1.39	BOLT, short		2
17	365-730	\$0.25	LOCKWASHER		4
18	NA		PULLEY, water pump		1

Lining up the various parts that use the radiator mounting bolts as support is easy when a tapered line-up tool is placed through the top holes to support one side while the opposite side is bolted. Install the top bolts first. Do not tighten any of the bolts until all four bolts are in place. The top bolts can be started using a deep well socket on a long extension with a nut in the socket to keep the bolt to the end of the socket. Most Sprites and Midgets have the two lower bolts missing. Get rid of a rattle or two by replacing them.

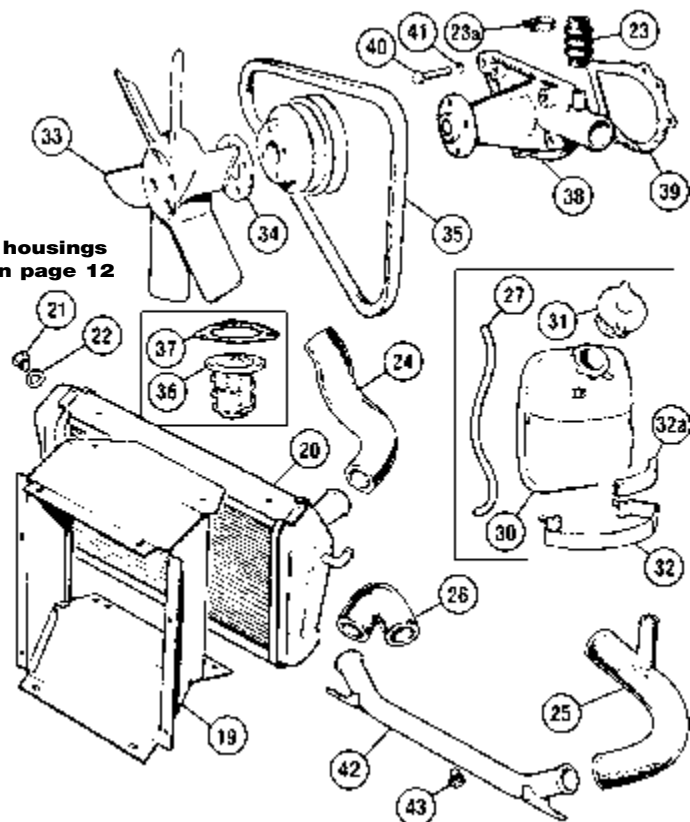

No.	Part No.	Price (each)	Description	Application	Qty. Req.
-----	----------	--------------	-------------	-------------	-----------

## Cross-Flow System (from 1968) 1275 from AH (c)72034 and MG (c)60441

19	459-765	\$249.99	COWL, radiator		1
20	459-735	\$199.99	RADIATOR, cross-flow		1
21	459-760	\$5.39	PLUG		1
22	328-485	NA	WASHER (use 328-486 O-ring to replace washer)		1
	328-486	\$0.39	O-RING (to replace washer)		1
23	434-530	\$6.79	HOSE, bypass, with original type hose clamps		1
23a	262-200	\$1.89	CLAMP, original band type		2
24	470-390	\$5.79	HOSE, top		1
25	470-395	\$13.79	HOSE, lower tube to pump		1
26	470-400	\$2.19	HOSE, radiator to lower tube		1
27	470-345	\$2.79	HOSE, radiator to expansion tank		1
30	459-690	\$89.99	EXPANSION TANK		1
31	459-695	\$3.79	CAP, expansion tank		1
32	459-691	\$21.99	STRAP, expansion tank		1
32a	459-692	\$1.99	PAD, rubber		1
33	434-560	\$35.99	FAN, plastic		1
34	NA		SPACER		1
35	434-600	\$3.99	FAN BELT		1
36	434-180	\$4.49	THERMOSTAT, 160°, hot climates		1
	434-189	\$4.49	THERMOSTAT, 180°, normal		1
	434-190	\$4.69	THERMOSTAT, 192°, cold climates		1
37	296-380	NA	GASKET, thermostat, stock type cork		1
	296-381	\$1.99	GASKET, thermostat, high strength "Klingersil"	<a href="#">MORE INFO ONLINE</a>	1
38	434-545	\$21.49	WATER PUMP		1
39	296-620	\$0.79	GASKET, water pump		1
40	322-105	\$0.99	BOLT, long		2
	191-915	\$1.39	BOLT, short		2
41	365-730	\$0.25	LOCKWASHER		4
42	434-520	\$39.79	PIPE		1
43	319-100	NA	DRAIN PLUG		1

### Wire Hose Clamps

	7/16" to 9/16"	326-475	\$1.69
	9/16" to 3/4"	635-100	\$1.79
	3/4" to 1"	635-101	\$1.89
	1" to 1 1/4"	326-410	\$2.39
	1 1/4" to 1 7/16"	326-465	\$1.69
	1 7/16" to 1 5/8"	326-440	\$2.19
	1 5/8" to 1 7/8"	635-102	\$1.89
	1 7/8" to 2"	031-724	\$2.90
	1 15/16" to 2 1/8"	635-103	\$4.49
	2 3/16" to 2 7/16"	326-230	\$2.49
	2 7/16" to 2 5/8"	326-460	\$2.49

MOSS

MOSS MOTORS, LTD.  
TOLL-FREE ORDERS

1-800-667-7872

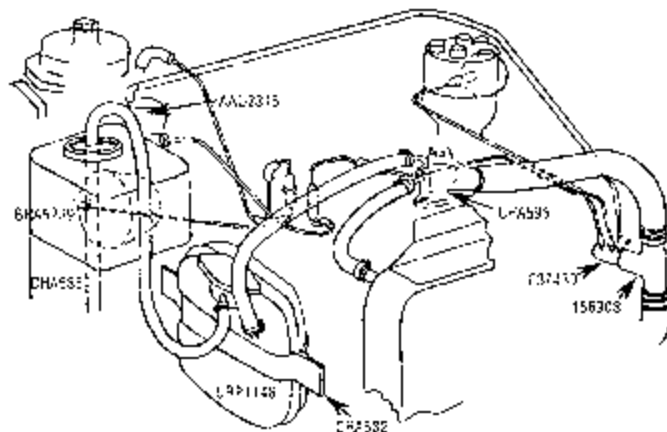
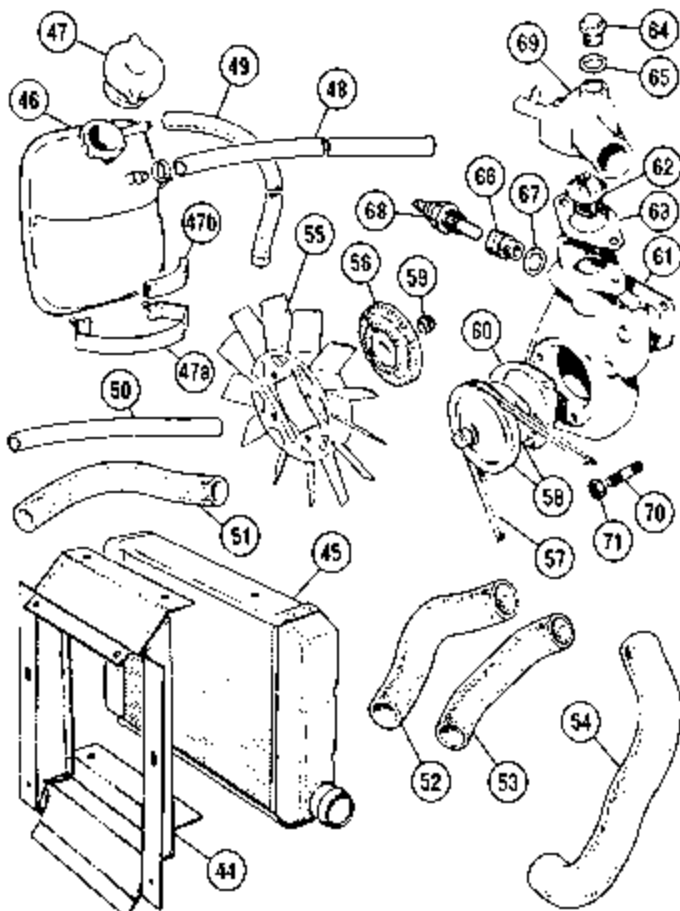

## 1975 Cooling System Modifications

The following is an extract from the Austin/ MG Technical Service Bulletin 75-A-6 dated August, 1975. **None of the specified parts are currently available.**

Where instance of severe overheating occurs on 1975 MG Midgets, the following modifications should be carried out.

1. Remove and discard the front number plate bracket and plinth assembly. Relocate and mount the front number plate to the center of the bumper, using self-tapping screws.
2. Reposition both horn assemblies by simply bending the mounting bracket upwards and through 90 degrees.
3. Install thermo-vac switch, Part No. C-37430 with 'T' sleeve adaptor, Part no. 158308 in the top radiator hose as shown.  
NOTE:- (Remove approximately 1 1/4" from the existing hose to accommodate the 'T' sleeve.)
4. Remove the decell valve from the carburettor and replace with externally vented valve, Part No. AAU-2346.
5. Remove and discard the existing expansion tank and replace with metal type, Part No. URP-1148, using the existing bolts and spacers and new brackets supplied, Part No. CHA-582.  
NOTE:- The pressure cap supplied with the metal tank has a double seal, and therefore is not interchangeable with the original cap which should be discarded.
6. Install bracket, Part No. CHA-585 and no-loss bottle, Part No. BHA-5239, utilizing the right-hand upper shock absorber support plate bolts.
7. Remove and discard the thermostat housing and install modified housing, Part No. CHA-595.
8. Connect the vacuum and water hoses as shown in overall illustration.  
NOTE:- Vacuum hose will have to be cut to length.
9. Pressure test system for any leaks.
10. Replace temperature gauge assembly, Part No. AAU-2641.  
NOTE:- There are many reasons why an engine will overheat, consequently it is essential to establish that no other problem exists, such as cylinder head gaskets, loose cylinder head bolts, incorrect ignition timing or maladjusted fan belt, etc., prior to carrying out the foregoing modifications.

No.	Part No.	Price (each)	Description	Application	Qty. Req.
<b>Cross-Flow System - 1500</b>					
44	459-775	\$179.99	COWL, radiator		1
45	459-740	\$189.99	RADIATOR	to (c)166303 (1975)	1
	459-745	NA	RADIATOR	from (c)166304 ('76 - on)	1
46	459-750*	NA	EXPANSION TANK	to (c)166303 (1975*)	1
	459-690	\$89.99	EXPANSION TANK (replacement)	from (c)166304 ('76 - on)	1
47	459-695	\$3.79	CAP, expansion tank		1
47a	459-691	\$21.99	STRAP, expansion tank		1
47b	459-692	\$1.99	PAD, rubber		1
48	470-305*	\$3.39	TUBE, to expansion tank	to (c)166303 (1975*)	1
	470-345	\$2.79	TUBE, to expansion tank	from (c)166304 ('76 - on)	1
49	470-340	\$3.89	TUBE, exp. tank to spill tank		1
50	470-345*	\$2.79	HOSE, thermo. hsg. to radiator	to (c)166303 (1975*)	1
51	470-405	\$6.99	HOSE, thermo. hsg. to radiator	from (c)166304 ('76 - on)	1
52	470-410*	\$6.89	HOSE, radiator to pump	to (c)166303 (1975*)	1
53	470-420	\$8.79	HOSE, radiator to pump	from (c)166304 ('76 - on)	1
54	470-415	\$6.99	HOSE, L/H, to thermo. hsg.		1
55	434-570	\$97.99	FAN		1
56	434-575	\$184.99	FAN CLUTCH		1
57	434-590	\$4.99	FAN BELT		1
58	835-655	\$53.99	WATER PUMP (includes pulley, tolerance ring, & gasket)		1
59	071-239 †	\$10.99	TOLERANCE RING†		1
† Must be replaced every time the fan clutch is removed and replaced (incl. w/pump).					
60	697-085	\$0.39	GASKET, water pump to housing		1
61	292-040	\$0.59	GASKET, housing to block		1
62	434-180	\$4.49	THERMOSTAT, 160°		1
	434-189	\$4.49	THERMOSTAT, 180°		1
63	292-101	\$1.49	GASKET, thermostat housing, Klingsilsil	<a href="#">MORE INFO ONLINE</a>	1
64	328-480	NA	PLUG, thermostat housing	original type	1
	459-760	\$5.39	PLUG, thermostat housing	brass replacement	1
65	328-485	NA	WASHER for plug		1
	328-486	\$0.39	O-RING (to replace washer)		1
66	361-065	\$7.49	ADAPTOR, temp. gauge	} thru (c)200000 (1977)	1
67	324-805	\$1.99	WASHER for adaptor		1
68	071-241	\$7.29	TEMPERATURE SENDER	from (c)200001-on (1978-on)	1
69	363-370*	NA	THERMOSTAT HOUSING	to (c)166303 (1975*)	1
		NA	THERMOSTAT HOUSING	1976-on	1
70	328-654	\$2.29	STUD, water pump		3
71	310-140	\$0.24	NUT		3

\*Note: Parts marked \* for 1975 are for unmodified cars only. See RH column for info.

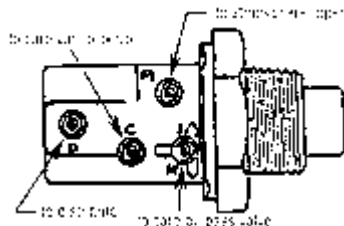

**Thermostatic Vacuum Switch**

## Hayden Electric Fan

Easy to install, these fans may be set up to run in either "pusher" (in front of the radiator) or "puller" (behind the radiator) configuration. The preset temperature control will turn the fan on at 185°F and off at 170°F. This 10" fan is 2-3/4" thick, and requires a clear mounting area of at least 10-5/8" x 11-1/8".



231-678 10" Cooling Fan Kit \$149.99

# Heaters

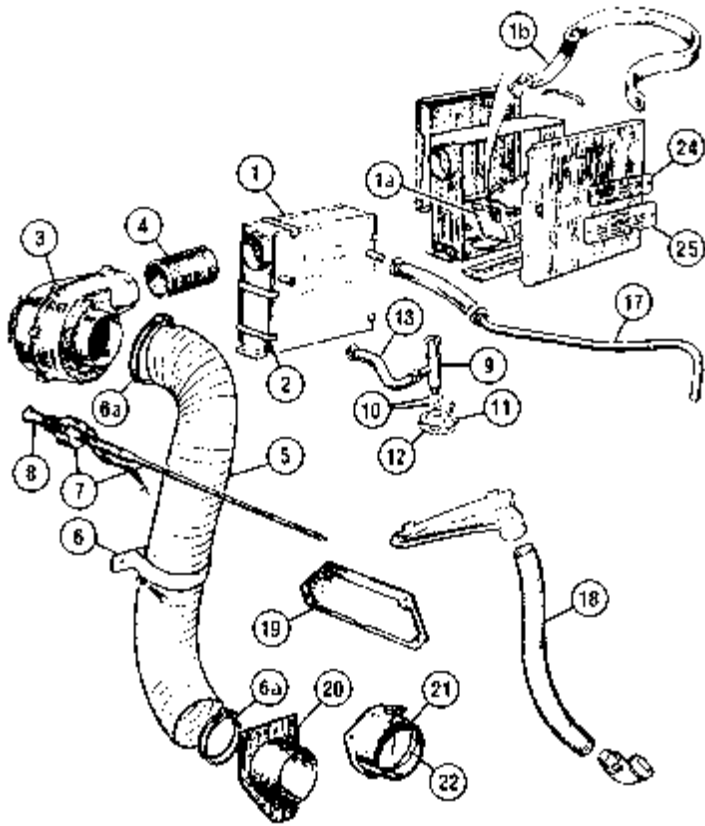

No.	Part No.	Price (each)	Description	Application	Qty. Req.
<b>948 - 1275 thru Sept. 1970 (GAN5-91406)</b>					
1	362-915	\$359.99	HEATER ASSEMBLY	} all through Sept., 1970	1
1a	360-675	\$78.49	RADIATOR, heater		1
1b	363-381	\$2.69	SEAL, foam		1
2	363-025	\$1.19	CLIP, heater box		A/R
3	362-905	NA	BLOWER ASSEMBLY	thru 1967	1
	362-925	\$389.99	BLOWER ASSEMBLY	1968-'70	1
4	363-390	\$5.79	AIR DUCT, fan to heater		1
5	456-130	\$54.99	AIR DUCT, replacement type		1
6	326-220	\$3.69	CLAMP		1
6a	326-255	\$8.29	HOSE CLAMP (wire type replacement)		2
7	331-690	NA	HEATER CONTROL, w/switch	Bugeye	1
	331-695	NA	HEATER CONTROL, w/switch	non-Bugeye thru 1966	1
	331-705	NA	HEATER CONTROL, w/switch	1967	1
	473-070	\$1.69	CABLE STOP		1
8	331-085	\$11.59	KNOB, heater control		1
9	360-400	\$19.99	HEATER VALVE		1
10	324-065	\$0.79	WASHER (may use more than one to align heater valve)	A/R	1
11	360-415	\$6.49	BASE, heater valve		1
12	296-455	\$0.69	GASKET, heater valve		1
13	363-320	\$9.99	HOSE, heater valve		1
17	635-065	\$39.99	PIPE, heater return		1
18	456-185	\$18.99	HOSE, demister	A/R	1
19	363-122	\$44.99	DOOR ASS'Y, heater outlet, stainless steel (with screws)		2
20	635-196	\$42.49	INLET FLANGE	Bugeye	1
21	NA		INLET FLANGE	non-Bugeye	1
22	363-415	\$16.99	SEAL, air inlet	non-Bugeye	1
23	408-350	\$4.69	PLATE, "Smiths" (rivetted)	thru 1967	1
	408-355	\$2.29	STICKER, "Smiths" (adhesive)	1968-'70	1
24	408-360	\$4.39	PLATE, "Caution" (rivetted)	thru 1967	1
	408-365	\$3.39	STICKER, "Caution" (adhesive)	1968-'70	1

The "water faucet" heater valve is one of the charming anachronisms of these cars. It's not so charming when it leaks. Part of your regular service routine should include tightening the mounting nuts. If the tap is leaking between the body and the mounting flange, a turn on the tap body should fix it. If not, replacement of the flange and gasket will cure the annoyance for good.

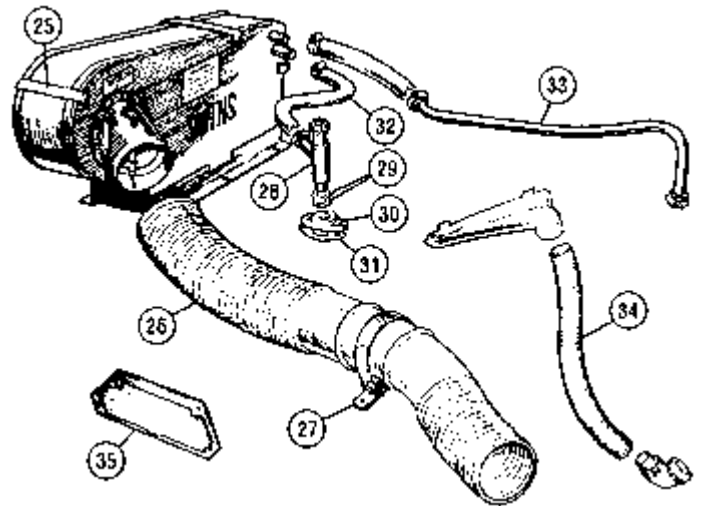

No.	Part No.	Price (each)	Description	Application	Qty. Req.
-----	----------	--------------	-------------	-------------	-----------

### 1275, Sept. 1970 (GAN5-91407)-'74

	360-705	\$154.99	HEATER CORE ("radiator")		1
25	363-380	\$3.79	CLIP, heater box		A/R
26	456-130	\$54.99	AIR DUCT, replacement type		1
27	326-220	\$3.69	CLAMP		1
28	360-400	\$19.99	HEATER VALVE		1
29	324-065	\$0.79	WASHER		A/R
30	360-415	\$6.49	BASE, heater valve		1
31	296-455	\$0.69	GASKET, heater valve		1
32	363-330	\$9.99	HOSE, heater valve		1
33	635-065	\$39.99	PIPE, heater return		1
34	456-185	\$18.99	HOSE, demister		A/R
35	363-122	\$44.99	DOOR ASS'Y, heater outlet, stainless steel (with screws)		2



### Cockpit-controlled Heater Valve

Tired of having to stop and open the hood to turn on your heater valve? Moss comes to the rescue with this cable-operated conversion which allows you to control your heater while seated comfortably in your car. It's a conversion you can easily do yourself. Fits 948, 1098 and 1275 engines. **635-375 \$68.99**

MOSS

MOSS MOTORS, LTD.  
TOLL-FREE ORDERS

**1-800-667-7872**

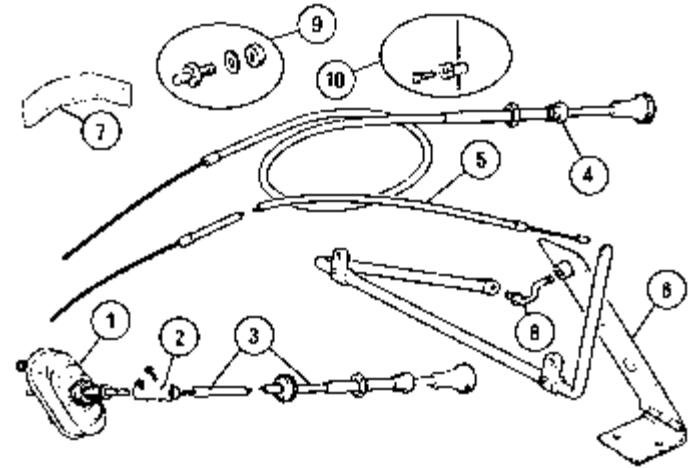
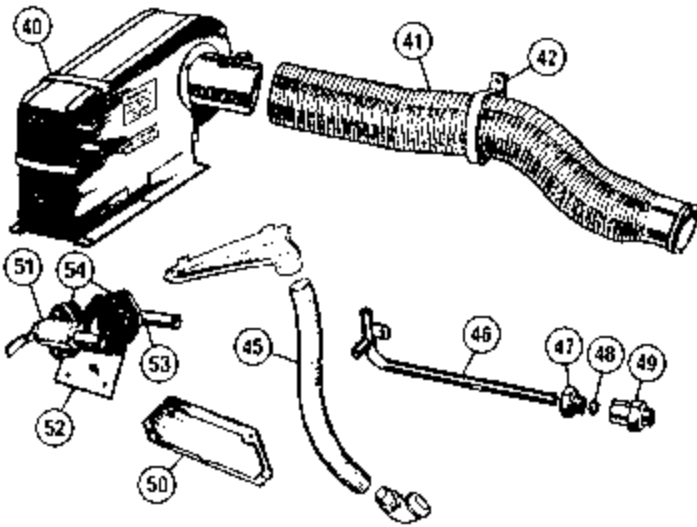

No.	Part No.	Price (each)	Description	Application	Qty. Req.
<b>1500</b>					
	360-705	\$154.99	HEATER CORE ("radiator")		1
40	363-380	\$3.79	CLIP, heater box	A/R	
41	456-130	\$54.99	AIR DUCT (replacement type without reduced end)		1
42	326-220	\$3.69	CLAMP		1
45	456-185	\$18.99	HOSE, demister	A/R	
46	865-115	\$36.99	PIPE, heater return (mild steel)		1
	635-105	\$44.99	PIPE, heater return (stainless steel)		1
47	635-150	\$2.89	TUBE NUT		1
48	635-160	\$1.39	COMPRESSION FITTING		1
49	635-170	\$8.79	ADAPTOR		1
50	363-122	\$44.99	DOOR ASS'Y, heater outlet, stainless steel (with screws)		2
51	360-425	NA	HEATER VALVE		1
52	360-426	\$11.99	BRACKET, heater valve		1
53	360-427	\$38.99	ELBOW, heater valve		1
54	697-360	\$0.39	GASKET, heater valve		2
	363-340	\$12.79	HOSE, heater valve to heater		1

No.	Part No.	Price (each)	Description	Application	Qty. Req.
-----	----------	--------------	-------------	-------------	-----------



### Engine Controls

1	145-800	\$24.89	SWITCH	948	1
2	161-500	\$8.89	COUPLING (with screws)	948	1
3	331-630	\$19.79	CABLE, starter pull, orig. type	Bugeye	1
	331-710	\$19.79	CABLE, starter pull, replacement	AH MkII, MG Mkl	1
4	331-720	\$15.99	CHOKE CABLE, original type	Bugeye	1
	331-080	\$23.99	CHOKE CABLE, repl. w/plain knob	948, 1098, 1275 (1967)	1
	331-240	\$17.59	CHOKE CABLE, "picture knob"	1275 1968	1
	331-645	\$19.99	CHOKE CABLE, "picture knob"	1275, 1970-'74	1
	331-490	\$21.49	CHOKE CABLE, "T-handle"replacement		1
	331-650	\$21.49	CHOKE CABLE	1500 w/o auto choke	1
5	331-006*	\$9.99	ACCELERATOR CABLE, Premium*	all except 1500	1
	331-731*	\$17.99	ACCELERATOR CABLE, Premium*	1500 not CA thru (c)188000	1
			*Premium cables with low friction liner. <a href="#">MORE INFO ONLINE</a>		
	331-740	NA	ACCELERATOR CABLE	{ 1500 CA only (c)160160 thru 188000	1
	331-750	\$21.49	ACCELERATOR CABLE	1500 from (c)188001 on	1
6	260-340	\$15.49	ACCELERATOR PEDAL, w/ hinge	all except 1500	1
	260-350	NA	ACCELERATOR PEDAL ASS'Y	1500	1
7	372-295	\$11.99	BRACKET, choke cable	Bugeye	1
8	260-345	\$8.79	LINK, accelerator pedal		1
9	375-108	\$2.19	CABLE STOP, accelerator cable		1
10	375-128	\$2.49	CABLE STOP, choke cable		1

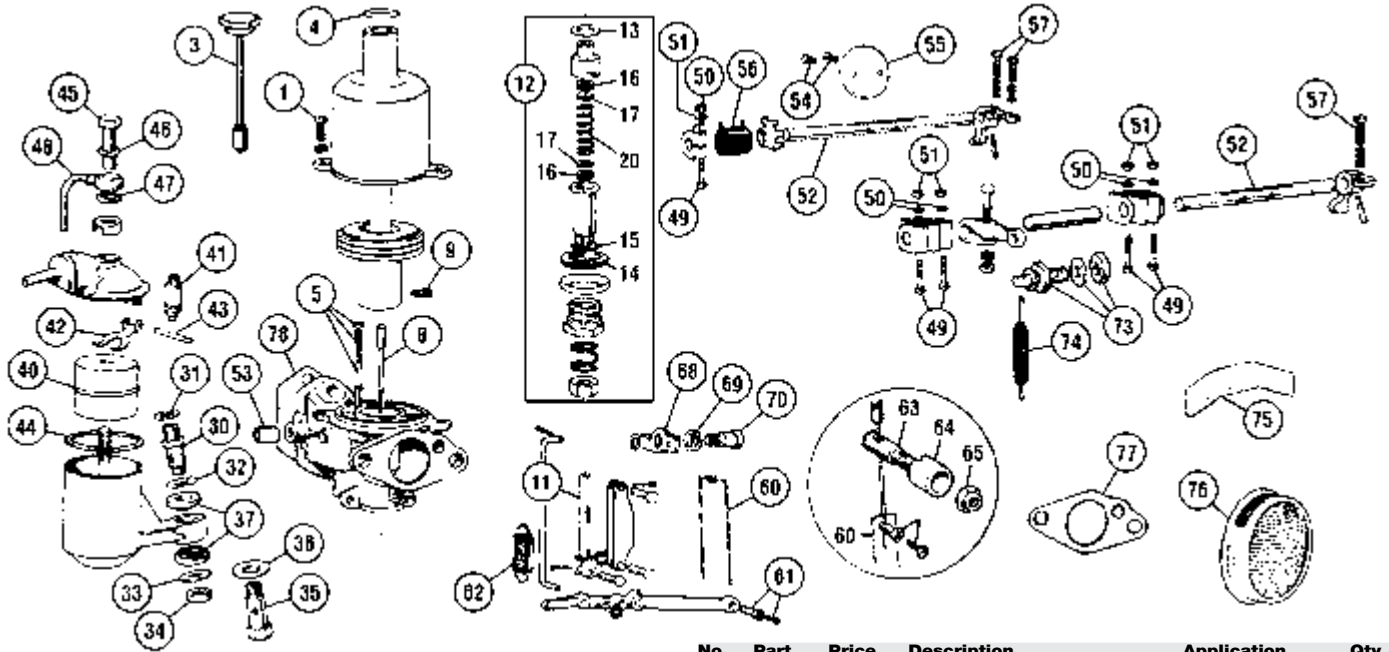
# Carburetors - Bugeye



## SU H-1 (1 1/8") "Bugeye" only (AUC863)

No.	Part No.	Price (each)	Description	Application	Qty. Req.
	375-460	\$104.99	<b>REBUILD KIT</b> , includes all items marked*, for 2 carburetors		1
	375-465*	\$32.99	GASKET KIT for 2 carburetors		1
1	370-290	\$0.79	SCREW, chamber, 2 per carb.		4
3	370-765	\$45.99	CAP & DAMPER, brass		2
	370-750	\$19.99	CAP & DAMPER, plastic replacement		2
4	370-650*	\$0.39	WASHER		2
5	375-048	\$9.99	PIN & SPRING ASS'Y.		2
8	374-095*	\$12.49	JET NEEDLE, standard (GG)		2
	374-055	\$12.49	JET NEEDLE, rich (EB)		2
	374-145	\$12.99	JET NEEDLE, lean (MOW)		2
9	370-180	\$3.99	SCREW, needle locking		2
11	370-760*	\$14.99	JET, .090"		2
12	370-395	\$35.99	JET BEARING KIT (stock type)		2
	370-396	\$64.99	JET BEARING KIT, "Superdry"  <a href="#">MORE INFO ONLINE</a>		2
13	370-250*	\$1.29	WASHER, jet bearing		2
14	295-000*	\$0.89	SEAL, cork		2
15	370-410*	\$0.89	WASHER, bottom jet bearing		2
16	295-200*	\$0.69	JET SEAL, cork		4
	365-420	\$0.89	O-RING, leak-free repl. for 295-200 (not in jet bearing kit)		4
17	370-230*	\$1.39	WASHER, cupped		4
20	370-070	\$2.79	SPRING, jet seal		2
30	372-190	\$12.99	STUD, float bowl to carb.	} alternative to #35 & 36	2
31	372-180	\$0.89	WASHER, fiber		2
32	372-200	\$1.29	WASHER, steel, flat		2
33	372-210	\$1.69	WASHER, steel, flat		2
34	311-230	\$0.59	NUT		2
35	370-080	\$13.89	BOLT, float bowl to carb.	} alternative to #30-34	2
36	370-030	\$3.69	WASHER, steel, cupped		2
37	370-021*	\$1.39	GROMMET, float bowl mount, Viton®		4
40	378-050	\$44.99	FLOAT		2
41	373-625*	\$16.99	NEEDLE & SEAT, Viton® tip 		2
	373-626	\$16.99	NEEDLE & SEAT, Viton® tip, aftermarket		2
	386-390	\$10.99	GROSE JET, superior replacement for original style needle & seat		2
42	378-130	\$11.99	LEVER, original cover		2
43	370-060*	\$0.89	PIN, lever		2
44	378-110*	\$0.89	GASKET, float bowl cover		2
45	370-150	\$6.99	BOLT, float bowl cover		2
46	370-130*	\$0.59	WASHER, aluminum		2
47	370-160*	\$0.99	WASHER, fiber		2
48	451-250	\$17.99	OVERFLOW PIPE		2
49	365-610	\$0.89	SCREW, coupling & clamp		5
50	365-620	\$0.79	WASHER		5
51	365-630	\$0.39	NUT		5
52	376-005	\$22.99	THROTTLE SHAFT, standard		2
	376-015	\$22.99	THROTTLE SHAFT, oversize diameter		2
53	330-490	\$3.49	BUSH, throttle shaft		4
54	370-090	\$1.79	SCREW, throttle disc		4
55	378-160	\$20.99	THROTTLE DISC		2
56	370-610	\$8.99	SPRING, front throttle shaft		1

No.	Part No.	Price (each)	Description	Application	Qty. Req.
57	370-340	\$0.59	SCREW, idle adjusting		3
60	378-010	\$10.79	STIRRUP		1
61	378-648	\$8.69	PIN ASS'Y., jet lever to stirrup		2
62	370-550	\$2.99	SPRING, choke return		2
63	378-570	\$29.99	PIN, choke control		1
64	378-575	\$20.99	COLLAR, choke control pin		1
65	311-610	\$0.79	NUT		1
66	378-648	\$8.69	CABLE STOP		1
68	378-230	NA	LEVER, fast idle		1
69	370-460	\$0.59	SPRING WASHER		1
70	370-450	\$7.99	BOLT, shouldered		1
73	375-108	\$2.19	PIN ASS'Y., throttle spring		1
74	370-335	\$1.19	SPRING, throttle		1
75	372-295	\$11.99	BRACKET, choke cable		1
76	373-420	\$38.69	AIR FILTER, front, repro. of original		1
	373-425	\$38.69	AIR FILTER, rear, repro. of original		1
77	295-010*	\$0.89	GASKET, filter to carb.		2
78	295-015*	\$0.79	GASKET, carb. to manifold (gasket set includes 2)		6



### SU Carb Rebuild Video

Anyone can tune or rebuild SU carbs with the help of our 2 hour and 40 minute video which uses a combination of sights, sounds and simple conversational dialog to unravel the mysterious SU. A "must" for home mechanics.

DVD 211-036 \$52.99

### SU Tool Kit

An assortment of handy tools for the home mechanic. Instructions included. Suitable for all cars with SU carbs.

386-300 \$21.99

### Carburetor Synchronizer

Used to synchronize airflow between multiple carbs, this is an indispensable tool for the serious home mechanic.

386-200 \$28.99

### SU Jet Wrench

Mixture adjustments on SU carbs (except HIF type) are much easier with the proper tool. 5/16 Whitworth size for original carbs. & replacement H-type, 17mm for new HS type carbs.

386-400 Jet Wrench, 5/16 W \$2.29 (included in SU Tool Kit)  
386-401 Jet Wrench, 17mm \$5.99

### SU Jet Centering Tool

Jet centering is critical on fixed needle SU carbs. This simple tool makes it a snap.

386-500 \$34.99



MOSS MOTORS, LTD.  
TOLL-FREE ORDERS

1-800-667-7872

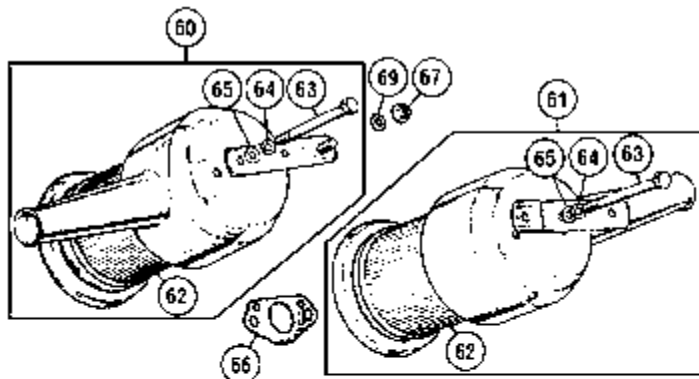
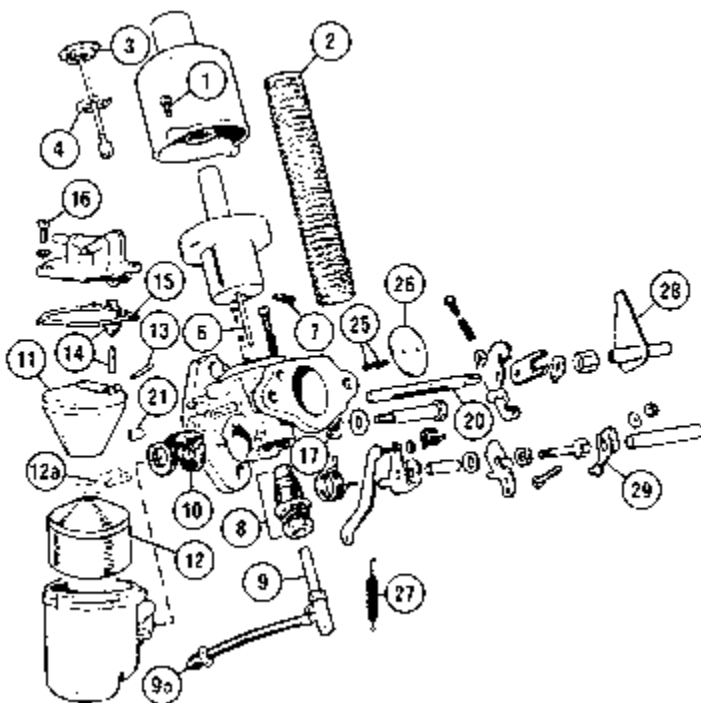

## SU HS-2 (1 1/4")

No.	Part No.	Price (each)	Description	Application	Qty. Req.
-----	----------	--------------	-------------	-------------	-----------

### New SU Carburetor Sets

Carburetor #	Application
370-708 \$944.99	AUC990F/990R 948 Sprite MkII, Midget Mkl
NA	AUD73F/73R (use 370-718) some very early 1098
370-718 \$944.99	AUD136F/136R 1098, 1963 - '67†
370-728 \$944.99	AUD266F/266R 1275, 1968†
370-908 \$949.99	AUD328F/328R 1275, 1969†
370-928 \$949.99	AUD404F/404R 1275, 1970 - '71†
370-938 NA	AUD502F/502R 1275, early 1972†
370-948 \$949.99	AUD549F/549R 1275, 1972 - '74†

375-538†\$149.99 **MASTER REBUILD KIT**, 2 carbs 948 thru 1275 (not Bugeye) ✨ 1  
 "Master Rebuild Kit" is a genuine S.U. kit. Includes all parts marked †.  
 Jet needles not included.

375-450*\$132.99	REBUILD KIT, for 2 carbs. ✨	948, except Bugeye	1
375-410*\$125.99	REBUILD KIT, for 2 carbs. ✨	1098, 1275 AUD136 & 266	1
375-420*\$125.99	REBUILD KIT, for 2 carbs. ✨	1275 AUD328 & 404	1
375-430*\$125.99	REBUILD KIT, for 2 carbs. ✨	1275 AUD502 & 549	1

375-435*†\$15.99	GASKET KIT, for 2 carbs. (incl. nos. 4, 15, 41, 42)		1
1 370-290 \$0.79	SCREW, chamber to body, 2 per carb.		4
2 370-530 \$5.99	SPRING, piston return		2
3 370-750 \$19.99	CAP & DAMPER, plastic cap		2
4 370-650*† \$0.39	WASHER		2

6 374-125 \$21.99	JET NEEDLE, lean (GX)	} 948 AUC990	2
374-305* \$13.99	JET NEEDLE, standard (V3)		2
374-295 \$12.99	JET NEEDLE, rich (V2)		2

374-095 \$12.49	JET NEEDLE, lean (GG)	} 1098/1275 AUD136/266 (original carbs)	2
374-005* \$12.89	JET NEEDLE, standard (AN)		2
374-135 \$12.49	JET NEEDLE, rich (H6)		2
021-079 \$28.99	JET NEEDLE, spring-loaded (AN)		repl. AUD136/266
374-355* \$14.59	JET NEEDLE, spring-loaded (AAC)	1275 AUD328 & 404	2
374-365* \$14.59	JET NEEDLE, spring-loaded (ABC)	1275 AUD502 & 549	2

7 370-180 \$3.99	SCREW, needle locking	straight needles	2
NA	SCREW, needle locking	spring-loaded needles	2
8 372-265 \$18.69	JET BEARING KIT	AUC990, AUD136	2
372-275 \$32.99	JET BEARING KIT	AUD266	2
372-285 \$33.99	JET BEARING KIT	AUD328, 404, 502, 549	2
9 378-430*†\$24.99	JET, front		1
378-440*†\$24.99	JET, rear		1
9a 378-400 \$0.95	SEAL to float bowl		2

No.	Part No.	Price (each)	Description	Application	Qty. Req.
10	378-090*	\$8.69	ADAPTOR, front		1
	378-085*	\$8.39	ADAPTOR, rear		1
11	378-470	\$9.99	FLOAT (as illustrated with metal hinge tab)		2
12	378-380	\$15.99	FLOAT, brass	} AUC990	2
12a	370-155	NA	LEVER for float #13		2
13	370-060	\$0.89	PIN, float	all	2
14	373-625*†	\$16.99	NEEDLE & SEAT, Viton® tip ✨		2
	373-626	\$16.99	NEEDLE & SEAT, Viton® tip, aftermarket		2
	386-390	\$10.99	GROSE JET, superior replacement for orig. style needle & seat.		2
15	378-360*†	\$1.49	GASKET, float chamber		2
16	370-290	\$0.79	SCREW, 3 per carburetor		6
17	378-070*	\$2.59	WASHER, rubber		2
20	378-370†	\$22.99	THROTTLE SHAFT		2
	378-375	\$24.99	THROTTLE SHAFT, oversize		2
21	330-490†	\$3.49	BUSH, throttle shaft		4
25	370-090†	\$1.79	SCREW, throttle disc		4
26	370-280†	\$16.79	THROTTLE DISC		2
27	370-335	\$1.19	SPRING, choke return		2
	370-320	\$1.29	SPRING, throttle return		1
28	370-121	\$17.99	LEVER, throttle		1
29	371-860	\$3.39	LEVER & PIN, front		1
	371-850	\$3.39	LEVER & PIN, rear		1
60	NA		AIR CLEANER ASSEMBLY, front		1
61	NA		AIR CLEANER ASSEMBLY, rear		1
62	950-260	NA	AIR FILTER ELEMENT, "Crosland" brand		2
	373-435	\$61.99	AIR FILTER ELEMENT, "K&N" brand		2
	950-760	\$9.29	AIR FILTER ELEMENT, various manufacturers		2
63	322-175	\$1.39	BOLT, air cleaner to carburetor		4
64	365-730	\$0.25	WASHER, locking		4
65	365-720	\$0.29	WASHER, plain		4
66	295-020*†	\$0.69	GASKET, air cleaner to carb.		2
67	310-290	\$0.69	NUT, nyloc, air cleaner straps		1
69	324-155	\$0.39	WASHER, plain		1



### Weber Carburetor Kits

Pick your choice of the traditional high performance side draft DCOE, or the popular DGV downdraft Weber carburetor kits. Please note there is no provision for emission control connections, and re-jetting may be required for best operation. We recommend the tuning be performed by a professional familiar with Weber carburetors.

222-440	\$879.99	Single 40DCOE	948, 1098	1
222-450	\$879.99	Single 45DCOE	1275	1
222-275	\$529.99	Single DGV	948, 1098, 1275	1

**LOCAL & OVERSEAS: 805-681-3400**  
**FAX: 805-692-2525** [www.mossmotors.com](http://www.mossmotors.com)



# Carburetors - Midget 1500

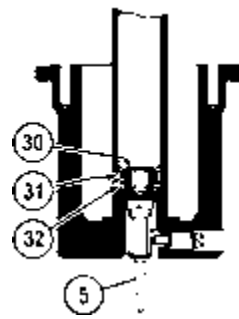
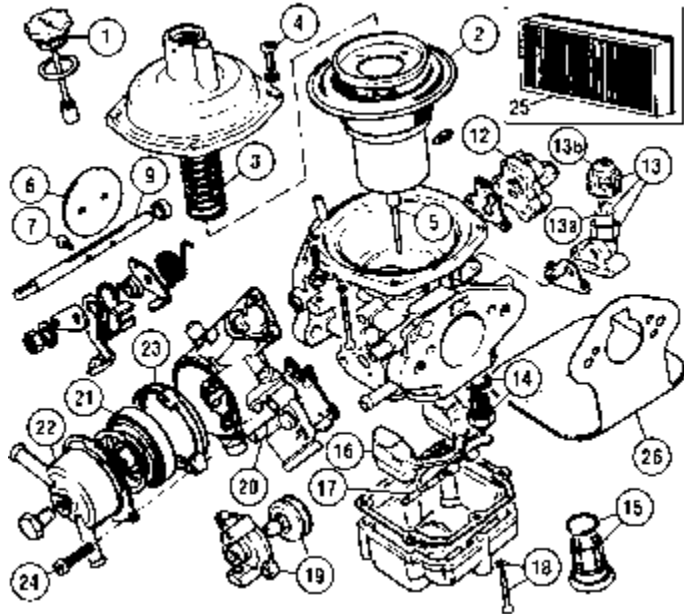

No.	Part No.	Price (each)	Description	Application	Qty. Req.
30	365-395	\$1.99	RETAINING CLIP	adjustable needle	1
31	365-420	\$0.89	O-RING		1
32	365-425	\$8.99	SCREW, needle adjusting		1

## Zenith-Stromberg 150-CD4T

No.	Part No.	Price (each)	Description	Application	Qty. Req.
	366-730	NA	CARBURETOR, C3754	Federal, 1975 - '76	1
	366-735	NA	CARBURETOR, C3838	Federal, 1977	1
	366-740	NA	CARBURETOR, C3962	Federal, 1978 on	1
	366-745	NA	CARBURETOR, C3755	California, 1975 - '76	1
	366-750	NA	CARBURETOR, C3863	California, 1977	1
	366-755	NA	CARBURETOR, C3963	California, 1978 on	1
	375-440	\$44.99	<b>REBUILD KIT</b> , includes all items marked * plus all seals and gaskets. Does not include metering needle.		1
	375-445	NA	GASKET KIT		1
	295-025	NA	GASKET, carb. to manifold		1
	295-030*	\$0.49	GASKET, air cleaner to carb.		1
1	366-660	\$27.99	CAP & DAMPER	C3754, 3838, 3755, & 3863	1
	366-665	\$25.99	CAP & DAMPER	C3962 & C3963	1
2	366-670*	\$2.79	DIAPHRAGM		1
3	366-675	\$6.89	SPRING, air piston		1
4	365-380	\$1.89	SCREW, cover to body		4
5	374-405	NA	METERING NEEDLE (44A)	C3754 & C3755, fixed	1
	374-415	\$28.99	METERING NEEDLE (44A)	C3838, adjustable	1
	374-425	\$27.99	METERING NEEDLE (45Q)	C3962, adjustable	1
	374-435	\$28.99	METERING NEEDLE (45K)	C3863, adjustable	1
	374-440	\$28.99	METERING NEEDLE (45R)	C3963, adjustable	1
6	366-680	\$9.79	THROTTLE DISC		1
7	366-685	\$1.89	SCREW, disc to shaft		2
9	366-690	\$14.49	THROTTLE SHAFT		1
12	366-695	\$79.99	BYPASS VALVE ASSEMBLY	C3754, 3755, 3863, & 3963	1
	366-700	\$99.99	BYPASS VALVE ASSEMBLY	C3838 & C3962	1
	365-745	\$15.79	DIAPHRAGM KIT, bypass valve		1
13	366-165	\$58.99	REGULATOR, idle air		1
13a	366-215	\$9.99	VALVE BODY, nylon		1
13b	366-245	\$7.99	COVER		1
14	366-705*	\$16.99	NEEDLE & SEAT ASSEMBLY		1
	386-350	\$14.69	GROSE JET, superior replacement for original style needle & seat.		1
15	366-070	\$12.99	PLUG & O-RING, float chamber		1
	365-470*	\$0.49	O-RING, float chamber plug		1
16	365-505	\$23.99	FLOAT ASSEMBLY		1
17	366-080	\$4.49	PIN, float pivot		1
18	366-305	\$1.99	SCREW & WASHER, float chamber, short	C3754, C3838, C3755, C3863	2
	366-065	\$3.49	SCREW & WASHER, float chamber, long		4
	366-295	\$1.99	SCREW & WASHER, float chamber		6
19	366-710	\$84.99	STARTER BOX	C3754	1
20	366-715	\$288.99	HOUSING ASS'Y., auto choke	} all except C3754	1
21	366-190	\$74.99	HEAT MASS ASS'Y., auto choke		1
22	366-200	\$22.99	COVER, heat mass		1
23	366-180	\$34.99	INSULATOR		1
24	366-175	\$1.19	SCREW, short		1
	366-185	\$1.49	SCREW, long		2
25	950-710	\$36.99	AIR FILTER ELEMENT, aftermarket		1
			See color pages at front of catalog for accessory air filters.		
26	375-480	NA	HEAT SHIELD		1

## 1500 Manual Choke Conversion Kit



Gain all the advantages of manually controlled choke, while leaving your car's original appearance intact by using this easy to install kit. Designed in England by Zenith-Stromberg engineers, this kit includes all necessary mounting hardware and detailed instructions.

**386-325 \$119.99**

Amendments to the Clean Air Act make it illegal for anyone to change or alter the emission control system of any automobile in the United States except for cars used exclusively for off-road use.

## Zenith-Stromberg Mixture Adjustment Tool



An essential item for owners of 1977 or later cars with a single Zenith-Stromberg carburetors with adjustable metering needles.

**386-310 \$9.69**

## Carburetor Dashpot Oil



Finally take all the guesswork out of what type of oil to use in your dashpots. Specially formulated for all SU and Zenith-Stromberg carburetors, this oil ensures the correct piston movement so critical for correct fuel mixture and optimum performance. You don't have to use engine oil any more. 125ml. supply should last a long time.

**220-225 \$11.99**

## Weber Downdraft Carb Kits



The Weber DGV two barrel progressive carburetor has proven to be the most popular replacement for worn out or damaged stock carburetors and gives a good combination of performance and economy on stock engines. Kits include instructions, carburetor(s), manifold/adapters, linkage and air filter(s). Please note that there is no provision for emission connections and some modifications will be required for best operation.

Midget 1500 (Water Choke)	222-255	\$559.99
Midget 1500 (Electric Choke)	222-256	\$559.99
Midget 1500 (Manual Choke)	222-257	\$529.99

May not be legal on emission controlled vehicles. Check your local laws for compliance.



# Emission Control

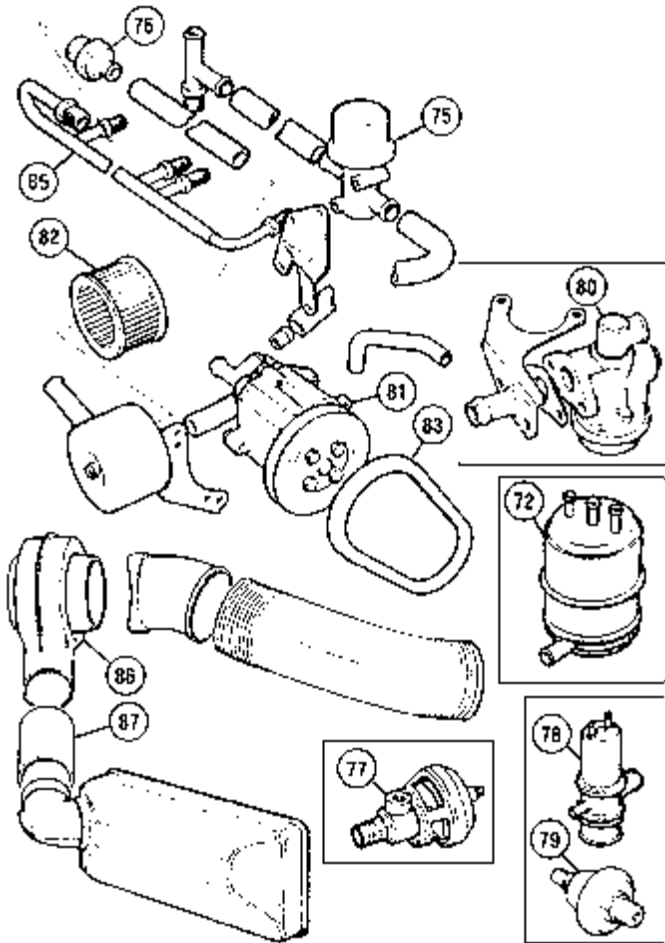

No.	Part No.	Price (each)	Description	Application	Qty. Req.
<b>Emission Control</b>					
72	367-100	\$66.99	CANISTER, vapor adsorption	} 1970 on	A/R*
	367-105	\$0.79	CAP (see note below)		1

\* Note: Adsorption canisters from (c)74886 thru 105500 had only 2 hose connections on top. These canisters are no longer available, and have been superseded by the later 3-connector canister which we supply. For cars requiring 2-connector canisters, use canister #367-100 with cap #367-105 to seal the connector not used. (Either outer connector may be used.) 1978-'80 used two canisters.

75	366-010	\$72.99	GULP VALVE	1275	1	
76	379-470	NA	CHECK VALVE, orig. mfr.	} 1275 & 1500	1	
	367-000	\$13.89	CHECK VALVE, aftermarket		1	
77	379-340	NA	E.G.R. VALVE	1500 thru 1976	1	
	379-365	NA	E.G.R. VALVE	1500, 1977 on	1	
78	367-110	\$82.99	VALVE, anti-run on	1500	1	
79	141-715	\$23.99	SWITCH, oil pressure	1500 Fed, CA thru 1977	1	
		NA	SWITCH, oil pressure	1500 CA from 1978 on	1	
80	379-610	NA	DIVERTER VALVE	1500 thru 1976	1	
	379-700	NA	GULP VALVE	1500, 1977-on, CA only	1	
81	360-775	\$284.99	AIR PUMP, rebuilt	} 1275	1	
	360-778	NA	AIR PUMP, replacement		1	
	379-555	NA	AIR PUMP		1500 thru 1976	1
	379-565	NA	AIR PUMP		1500, 1977 on	1
82	950-230	NA	FILTER ELEMENT, "Crosland"	} 1275 & 1500	1	
	950-730	\$9.99	FILTER ELEMENT, various mfr.		1	
83	434-580	\$4.99	BELT, air pump	1275	1	
	379-620	\$6.49	BELT, air pump	1500	1	
85	379-630	NA	AIR MANIFOLD	1275	1	
	379-640	NA	AIR MANIFOLD	1500, '75 - '76	1	
	379-645	NA	AIR INJECTION PIPE	1500, '77 - '80	1	
86	373-920	NA	TEMP. COMPENSATOR	} 1500	1	
87	379-660	NA	CONNECTOR		1	

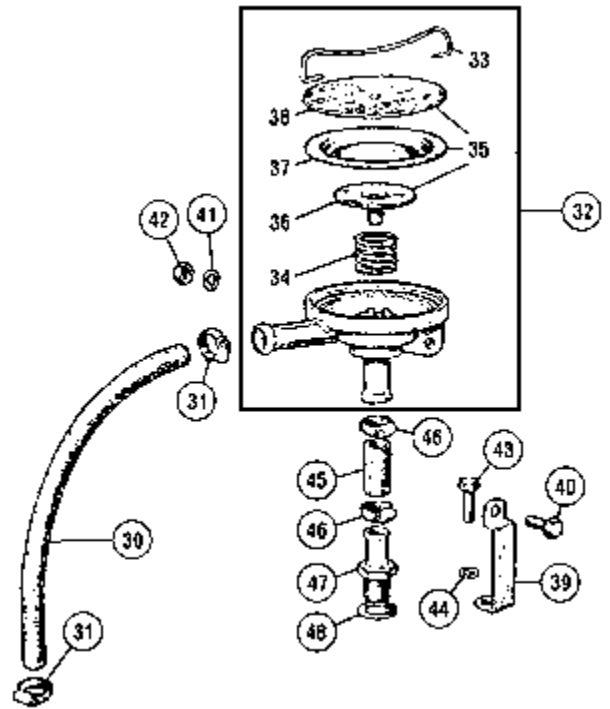

No.	Part No.	Price (each)	Description	Application	Qty. Req.
30		NA	HOSE, breather	} 1098 10CC & 1275 to engine 12CD/DA/H8700	1
31	470-381	\$3.49	CLIP, hose to separator & valve		2
32	360-630	\$48.99	P.C.V. VALVE		1
33		NA	CLIP, cover		1
34		NA	SPRING		1
35		NA	SERVICE KIT, valve		1
36		NA	PLUNGER SUB-ASSEMBLY		1
37	360-635	\$3.89	DIAPHRAGM		1
38		NA	COVER		1
39		NA	SUPPORT BRACKET		1
40	322-230	\$0.19	BOLT, valve to bracket		1
41	324-020	\$0.20	WASHER, locking		1
42	310-760	\$0.39	NUT		1
43	322-645	\$0.49	BOLT, bracket to manifold		1
44	324-040	\$0.29	WASHER, locking	1	
45		NA	HOSE, valve to adaptor	1	
46	470-381	\$3.49	CLIP, hose to valve & adaptor	2	
47	372-470	\$11.79	ADAPTOR, hose to manifold	1	
48	324-145	\$0.29	WASHER, sealing	1	

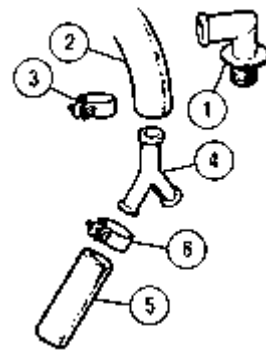

1		NA	ADAPTOR, sensing control	} 1275 from (e)12CD-DA-H8701	1
2		NA	HOSE, Y-piece to separator		1
3	117-015	\$1.89	HOSE CLAMP		1
4	367-070	\$4.69	"Y" PIECE		1
5		NA	HOSE to carburetor		2
6	326-250	\$0.69	HOSE CLAMP		2

**LOCAL & OVERSEAS: 805-681-3400**  
**FAX: 805-692-2525**      [www.mossmotors.com](http://www.mossmotors.com)

**MOSS**

# Fuel System

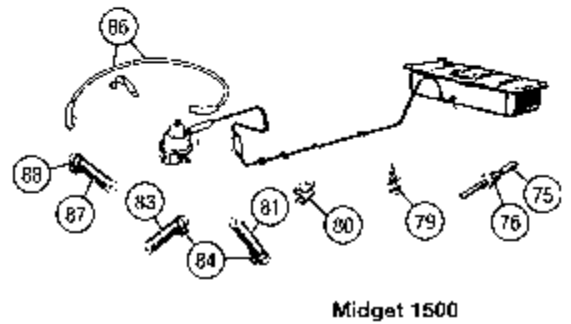
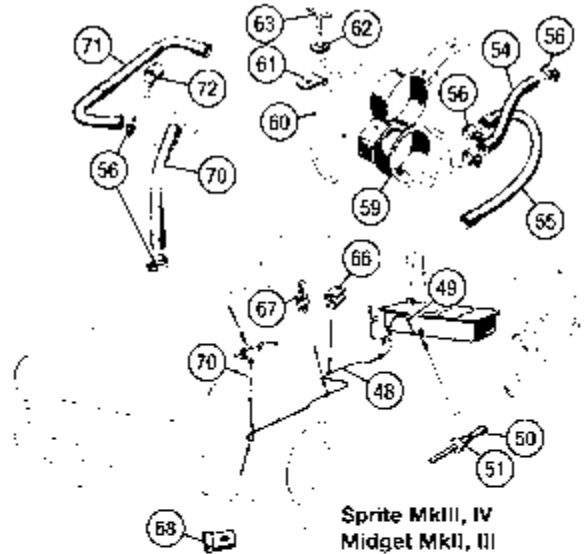
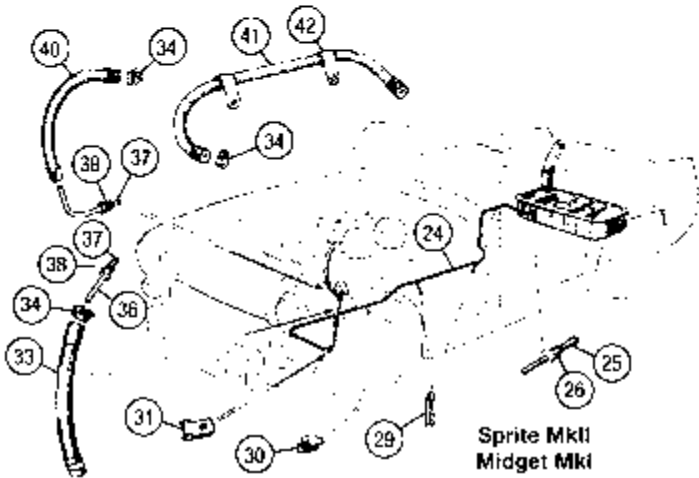
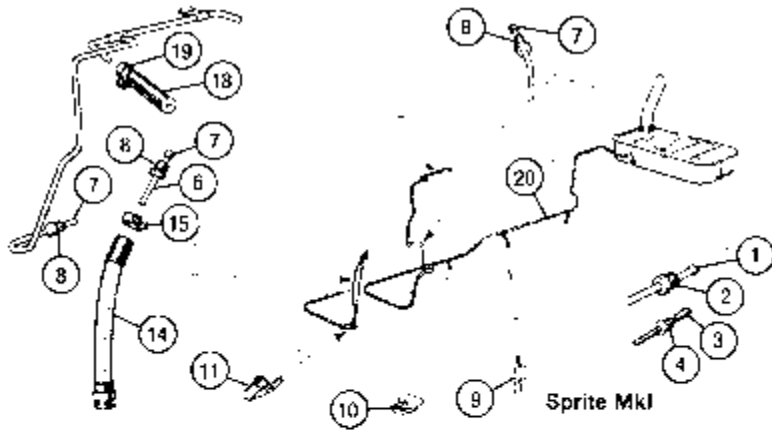

No.	Part No.	Price (each)	Description	Application	Qty. Req.
-----	----------	--------------	-------------	-------------	-----------

### Sprite MkI ("Bugeye")

1	376-565	\$0.59	COMPRESSION SLEEVE, pipe to tank	} Sprite MkI to (c)41015	1
2	376-575	\$5.49	TUBE NUT, pipe to tank		1
3	376-570	\$4.19	NIPPLE, pipe to tank	} Sprite MkI from (c)41016	1
4	376-572	\$5.89	TUBE NUT, pipe to tank		1
6	376-783*	\$20.49	PIPE, hose to pump *		1
7	376-565	\$0.59	COMPRESSION SLEEVE, pipes to pump		2
8	376-575	\$5.49	TUBE NUT, pipes to pump		2
9	582-925	\$0.89	CLIP, fuel pipe to body		2
10	162-356	\$0.99	CLIP, fuel pipe to body		3
11	162-220	\$0.89	CLIP, fuel pipe to engine mount bracket		1
14	376-915	\$7.99	HOSE, pump inlet	} Sprite MkI from (c)41016	1
15	117-015	\$1.89	HOSE CLAMP		2
18	379-205	\$0.99	HOSE, pipe to carb		2
19	326-310	\$1.49	HOSE CLAMP		4
20	376-784*	\$54.99	PIPE, tank to pump *	Sprite MkI to (c)41015	1
	376-782*	\$51.79	PIPE, tank to pump *	Sprite MkI from (c)41016	1

### Sprite MkII, Midget MkI

24	376-782*	\$51.79	PIPE, main *		1
25	376-570	\$4.19	NIPPLE, pipe to tank		1
26	376-572	\$5.89	TUBE NUT, pipe to tank		1
29	582-925	\$0.89	CLIP, fuel pipe to body		2
30	162-356	\$0.99	CLIP, fuel pipe to body		3
31	162-220	\$0.89	CLIP, fuel pipe to engine mount bracket		1
33	376-915	\$7.99	HOSE, pump inlet		1
34	117-015	\$1.89	HOSE CLAMP		6
36	376-783*	\$20.49	PIPE, hose to pump *		1
37	376-565	\$0.59	COMPRESSION SLEEVE, pipes to pump		2
38	376-575	\$5.49	TUBE NUT, pipes to pump		2
40	376-885	\$7.49	HOSE, pump to carb		1
41	376-945	\$7.99	HOSE, carb to carb		1
42	162-355	\$7.99	SUPPORT, hose		2

\* Pipes include required Compression Sleeve(s) and Tube Nut(s)

No.	Part No.	Price (each)	Description	Application	Qty. Req.
-----	----------	--------------	-------------	-------------	-----------

### Sprite MkIII, IV; Midget MkII, III

48	376-786	\$43.99	PIPE, main		1
49	376-781	\$29.99	PIPE, tank to pump		1
50	376-570	\$4.19	NIPPLE, pipe to tank		1
51	376-572	\$5.89	TUBE NUT, pipe to tank		1
54	376-915	\$7.99	HOSE, pump inlet		1
55	376-880	\$7.79	HOSE, pump outlet		1
56	117-015	\$1.89	HOSE CLAMP		8
59	377-360	\$2.49	GROMMET, fuel pump mount		1
60	361-220	\$0.89	VENT LINE, fuel pump	(sold per foot)	2
61	162-210	\$1.19	P-CLIP, vent line		1
62	281-050	\$5.49	GROMMET		1
63		NA	T-FITTING		1
66	162-356	\$0.99	CLIP, fuel pipe to body		3
67	582-925	\$0.89	CLIP, fuel pipe to body		2
68	162-220	\$0.89	CLIP, fuel pipe to engine mount bracket		1
70	376-885	\$7.49	HOSE, pipe to carb		1
71	376-945	\$7.99	HOSE, carb to carb		1
72	162-355	\$7.99	SUPPORT, hose		2

### Midget 1500

75	376-570	\$4.19	NIPPLE, pipe to tank		1
76	376-572	\$5.89	TUBE NUT, pipe to tank		1
79	582-925	\$0.89	CLIP, fuel pipe to body		2
80	162-356	\$0.99	CLIP, fuel pipe to body		2
81	379-210	\$1.49	HOSE, pipe connecting		1
83	379-205	\$0.99	HOSE, pipe to pump		1
84	326-310†	\$1.49	HOSE CLAMP †		4
86	589-300	NA	PIPE, pump to carb		1
87	379-250	\$0.79	CONNECTOR, pipe to pump & carb		2
88	051-191	\$1.49	HOSE CLAMP *		4

† Original 1500 hose clamps were barrel type, and do not fit replacement hoses. Band type replacement clamps are listed here.

MOSS

MOSS MOTORS, LTD.  
TOLL-FREE ORDERS

1-800-667-7872

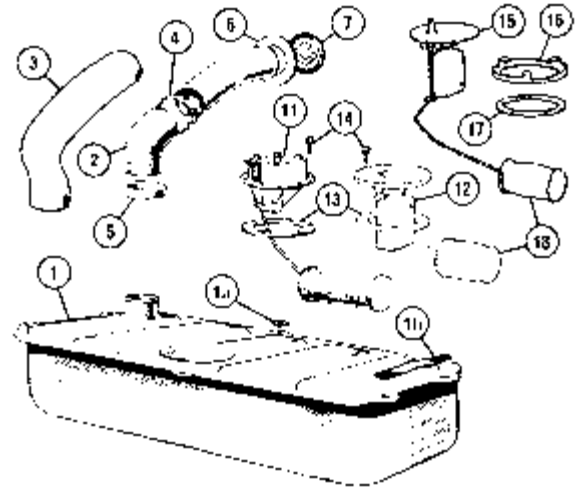
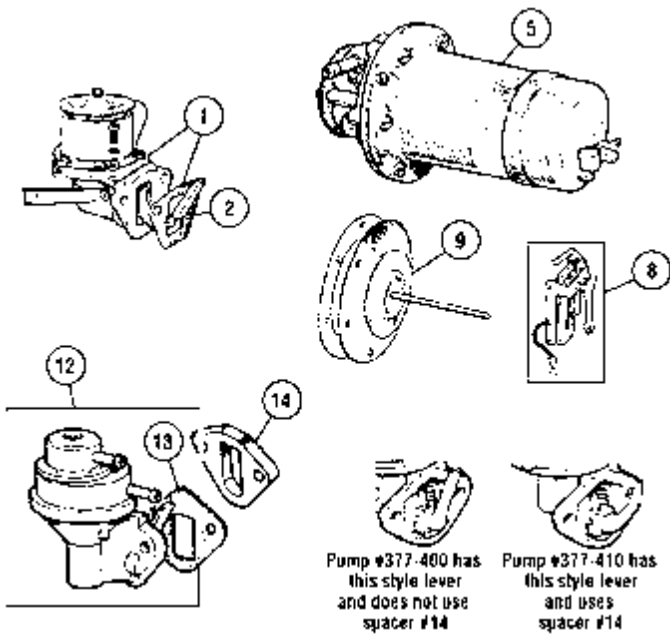

No.	Part No.	Price (each)	Description	Application	Qty. Req.
1	377-390	\$49.99	FUEL PUMP, mechanical	} 948, 1098 (10CG)	1
	377-395	NA	REBUILD KIT, fuel pump		1
2	296-220	\$0.69	GASKET, fuel pump		1
5	377-175	\$176.99	FUEL PUMP, original SU	} 1098 (10CC) & 1275	1
	377-176	\$139.99	FUEL PUMP, plastic replacement		1
8	377-080	\$20.49	POINT SET		1
9	377-130	\$46.99	DIAPHRAGM, 2 3/8" shaft		} as required
	377-140	\$49.99	DIAPHRAGM, 2 15/16" shaft	1	
12	377-400	\$30.89	FUEL PUMP, mechanical, does not use spacer	} 1500 thru 1977	1
	377-410	\$29.99	FUEL PUMP, mechanical, requires spacer block This pump must be used with the spacer no. 14 below.		1
	377-405	NA	REBUILD KIT, fuel pump	} all 1500	1
13	697-125	\$0.69	GASKET		1/2
14	377-415	\$10.29	SPACER (used without gaskets)	1500, 1978 on	1

No.	Part No.	Price (each)	Description	Application	Qty. Req.
-----	----------	--------------	-------------	-------------	-----------

Underlined part numbers indicate an Oversize Parts Fee will be charged. See [mossmotors.com](http://mossmotors.com) or call for details.

1	<u>471-189*</u>	\$169.99	FUEL TANK* (detachable filler neck)	Bugeye	1
	<u>471-231*</u>	\$159.99	FUEL TANK*	non-Bugeye thru 1969	1
	<u>471-241*</u>	\$159.99	FUEL TANK*, evaporative loss control	1970 - '71	1
	<u>471-251*</u>	\$159.99	FUEL TANK*	1972 on	1
* Classic Gold brand					
1a	280-106	\$1.39	WASHER, rubber, fuel tank mount	} thru 1969	2
1b	280-107	\$3.69	STRIP, rubber, fuel tank mount		2
2	282-945	\$18.99	HOSE, filler to tank	thru 1275 (not Bugeye)	1
	282-920	\$33.89	HOSE, filler to tank (as illus)	1500 (as fitted)	1
3	282-946	\$39.99	HOSE, filler to tank (long S-shaped)	1500 (as fitted)	1
4	326-460	\$2.49	CLAMP, filler hose		2
5	282-930	\$1.39	SEAL, tank to trunk floor		1
6	280-105	\$3.99	GROMMET, filler neck		1
7	202-750	\$16.99	GAS CAP	thru 1969	1
	202-755	\$11.79	GAS CAP	1970 on, except CA 1500	1
	202-765	\$19.49	GAS CAP	CA 1500 (c) 160160 to 166300	1
	202-755	\$11.79	GAS CAP	CA 1500 from (c)166301	1
11	361-880	\$57.99	SENDING UNIT (thru 1967) (w/ plastic float no. 18)	} Bugeye MG to (c)60459 AH MkII - MKIV to (c)72039	1
12	361-890	\$35.79	SENDING UNIT (1968-'71)		} MG from (c)60460 105500 AH from HAN9-72040 on
13	293-415	\$0.49	GASKET, cork	} all through 1971	
	293-401	\$5.99	GASKET, ethanol-proof (incl. cover gasket for 361-880)		1
14	323-030	\$0.29	SCREW, sending unit to tank		6
15	361-900	\$25.99	SENDING UNIT	} MG 1972 on	1
16	360-665	\$0.99	RING, locking		1
17	293-410	\$2.99	RING, sealing		1
18	360-645	\$8.49	FLOAT, plastic	} orig. units 1968-'80 & Moss 361-880	1
	360-646	\$12.99	FLOAT, brass, replacement		1

## Facet Solid State Electric Fuel Pump

Solid State electronic fuel pumps can be used in conjunction with, or in place of your original pump. This solid state pump will push or pull fuel, from a hidden location under the car, through your original pump. It may be put in-line with a power switch and used as a backup. Works on positive or negative ground cars.

377-420 \$89.99



## Facet Fuel Filter

74 micron filter is recommended for use on the inlet port of the Facet pump above. Filter screws directly into the inlet port.

377-424 \$10.99



## Ethanol Resistant Fuel Hose

Gates "Barricade" hose is the lowest permeation multi-fuel compatible hose on the market. Rated for 50 psi at -40 to 257 degrees F, and compatible with all gasoline blends. Sold per inch.

1/4" ID hose 379-214 \$0.29 per inch  
5/16" ID hose 434-451 \$0.29 per inch



## Locking Gas Cap

Our chrome locking fuel filler caps are similar to originals, but with an important extra feature. With fuel prices as high as they are, a locking gas cap is inexpensive insurance against thieves. Supplied complete with two keys. Fits Sprites and Midgets from 1959 through 1969.

202-760 \$37.99

LOCAL & OVERSEAS: 805-681-3400

FAX: 805-692-2525 [www.mossmotors.com](http://www.mossmotors.com)

MOSS

# Manifolds and Heatshields 948 - 1098

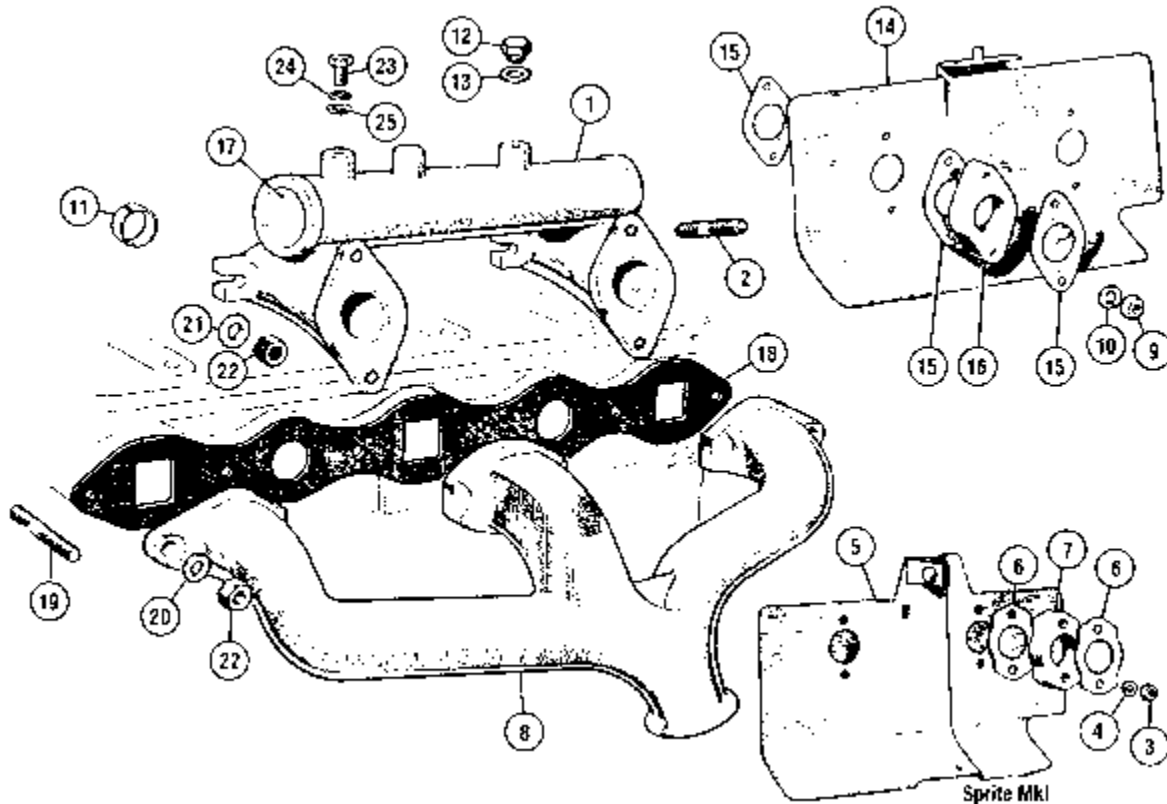

No.	Part No.	Price (each)	Description	Application	Qty. Req.
-----	----------	--------------	-------------	-------------	-----------

### Sprite Mkl (948 9C engine)

1	NA		INLET MANIFOLD, (for 1 1/8" carbs)		1
2	328-766	\$5.39	STUD, carb to manifold		4
3	310-760	\$0.39	NUT		4
4	324-020	\$0.20	WASHER, spring		4
5	444-364	\$78.99	HEAT SHIELD		1
6	295-015	\$0.79	GASKET		6
7	NA		SPACER		2
8	NA		EXHAUST MANIFOLD		1

### Sprite MklII & Midget Mkl (948 9CG & 1098 10CG engines)

1	444-363	\$339.99	INLET MANIFOLD, (for 1 1/4" carbs)		1
2	328-767	\$2.99	STUD, carb to manifold		4
8	NA		EXHAUST MANIFOLD		1
9	310-070	\$0.39	NUT, thin		4
10	324-860	\$0.19	WASHER, flat		4
11	372-371	\$2.19	RING, locating	from 10CG/DA/H18628	2
12	379-362	\$8.99	PLUG, blanking		1
13	324-145	\$0.29	WASHER, sealing		1
14	372-430	\$24.79	HEAT SHIELD		1
15	294-500	\$0.69	GASKET		6
16	372-375	\$34.99	SPACER		2

### Sprite MklIII & Midget MklII (1098 10CC engines)

1	444-363	\$339.99	INLET MANIFOLD, (for 1 1/4" carbs)		1
2	328-767	\$2.99	STUD, carb to manifold		4
8	444-185	\$269.99	EXHAUST MANIFOLD		1
9	310-070	\$0.39	NUT, thin		4
10	324-860	\$0.19	WASHER, flat		4
11	372-371	\$2.19	RING, locating		2
12	379-362	\$8.99	PLUG, blanking		1
13	324-145	\$0.29	WASHER, sealing		1
14	372-430	\$24.79	HEAT SHIELD		1
15	294-500	\$0.69	GASKET		6
16	372-375	\$34.99	SPACER		2

No.	Part No.	Price (each)	Description	Application	Qty. Req.
-----	----------	--------------	-------------	-------------	-----------

### All 948, 1098

17	319-095	\$1.49	CORE PLUG	to 9CG DAH 3169	2
	444-362	\$1.39	CORE PLUG	from 9CG DAH 3170	2
18	296-630	\$1.89	GASKET, manifold to head		1
19	328-664	\$1.49	STUD, manifolds to head		6
20	365-720	\$0.29	WASHER, flat	for outer studs	2
21	324-365	\$0.89	WASHER, special	for inner studs	4
22	311-540	\$0.59	NUT, brass		6
23	310-489	\$0.19	SCREW		2
24	324-020	\$0.20	WASHER, spring		2
25	324-590	\$0.19	WASHER, flat		2



### Exhaust Headers

Hand built to obtain maximum power, full bore bends and smooth pipe junctions mark these quality headers.

948	452-060	\$379.99
1098/1275 (illus.)	452-065	\$399.99
1500*	452-070	\$399.99

\*1500 header is for use with carburetor conversions, and will not fit with the stock Zenith-Stromberg intake manifold.

MOSS

MOSS MOTORS, LTD.  
TOLL-FREE ORDERS

1-800-667-7872

# Manifolds and Heatshields 1275 - 1500

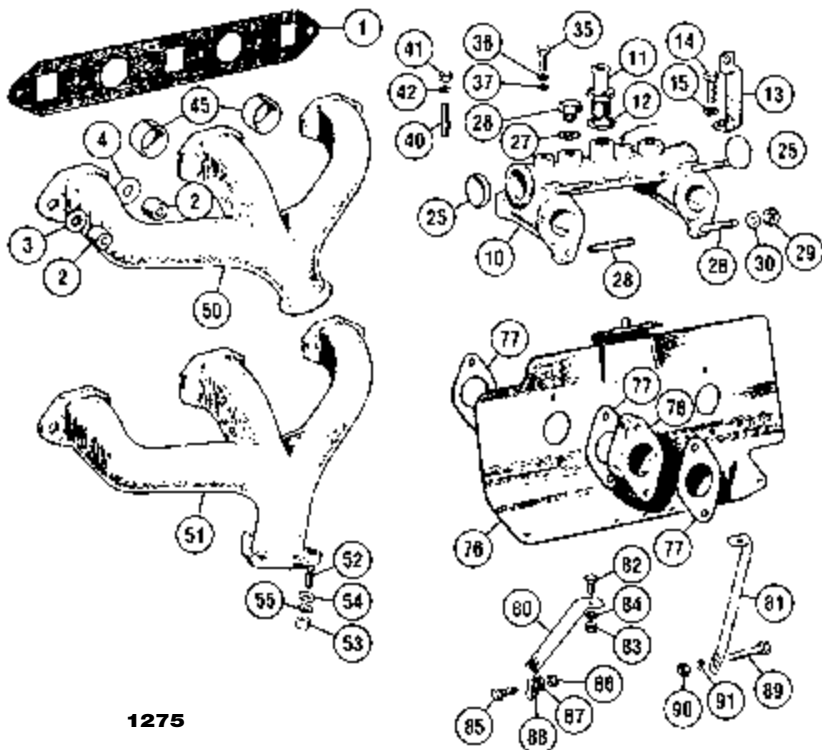

1275

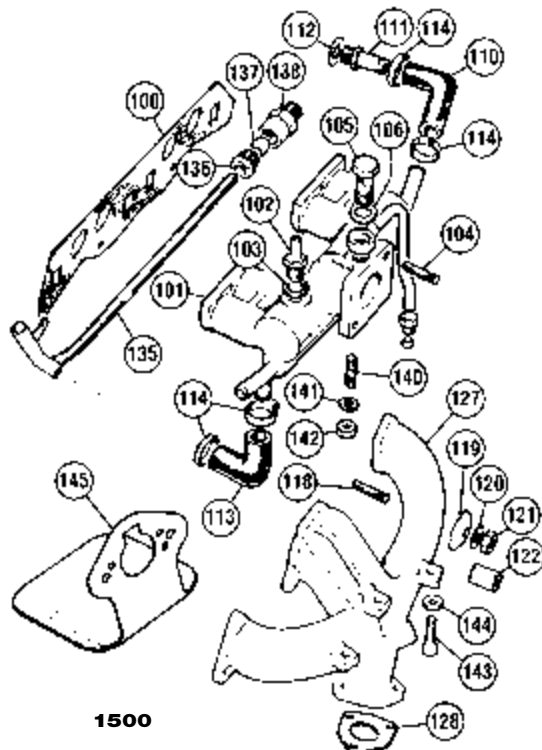

1500

No.	Part No.	Price (each)	Description	Application	Qty. Req.	No.	Part No.	Price (each)	Description	Application	Qty. Req.
<b>Manifolds &amp; Heatshields, 1275</b>											
1	296-630	\$1.89	GASKET, manifolds		1	85	314-265	\$0.49	BOLT, bracket to timing cover		1
2	311-540	\$0.59	NUT, brass, manifold to head		2	86	310-760	\$0.39	NUT		1
3	365-720	\$0.29	WASHER, plain, exhaust manifold to head		6	87	324-020	\$0.20	WASHER, locking	} approx. Dec 1967 on	1
4	324-365	\$0.89	WASHER, manifolds to head		4	88	324-590	\$0.19	WASHER, plain		1
10	444-363	\$339.99	MANIFOLD, inlet		1	89	322-105	\$0.99	BOLT, bracket to engine back plate	1	
11	372-470	\$11.79	ADAPTOR, PCV valve		1	90	310-290	\$0.69	NUT, nyloc	1	
12	324-145	\$0.29	WASHER, sealing		1	91	365-720	\$0.29	WASHER, plain	1	
13		NA	BRACKET, PCV valve		1	<b>Manifolds &amp; Heatshield, 1500</b>					
14	322-645	\$0.49	SCREW, bracket to manifold		1	100	694-120	\$8.99	GASKET, manifold, Payen brand		1
15	324-020	\$0.20	WASHER, locking		1	101		NA	MANIFOLD, inlet	1975-'76	1
25	444-362	\$1.39	CORE PLUG		2			NA	MANIFOLD, inlet	1977-'80	1
26	379-362	\$8.99	PLUG, threaded		1	102		NA	ADAPTER		1
27	324-195	\$1.29	WASHER, sealing		1	103	324-065	\$0.79	WASHER, fiber		1
28	328-767	\$2.99	STUD, carburettor mounting		4	104	328-660	\$1.59	STUD, carburetor		2
29	310-050	\$0.59	NUT		4	105		NA	BOLT, banjo	} 1975-'76	1
30	324-040	\$0.29	WASHER, locking		4	106		NA	WASHER		2
35	310-489	\$0.19	SCREW, clip to inlet manifold		1	110	834-550	NA	HOSE, manifold to thermo. housing		1
36	324-020	\$0.20	WASHER, locking		1	111	379-680	\$8.99	ADAPTOR to thermo. housing		1
37	324-590	\$0.19	WASHER, plain		1	112	370-650	\$0.39	WASHER		1
40		NA	STUD		1	113	834-550	NA	HOSE, pipe to manifold	1975-'76	1
41	310-760	\$0.39	NUT		1			NA	HOSE, pipe to manifold	1977-'80	1
42	324-020	\$0.20	WASHER, locking		1	114	326-250	\$0.69	HOSE CLAMP		4
45	372-371	\$2.19	SLEEVE, inlet manifold to head		2	118	328-650	\$2.29	STUD, manifolds to head (1-7/8")		6
50	444-185	\$269.99	MANIFOLD, exhaust	clamp type	1			328-660	\$1.59	STUD, exhaust manifold to head (1-3/8")	2
51		NA	MANIFOLD, exhaust	flange type	1	119	812-025	\$5.39	CLAMP, long		2
52	328-765	\$1.09	STUD, exhaust manifold to down pipe		3			812-010	\$4.99	CLAMP, short	4
53	311-540	\$0.59	NUT, brass		3	120	324-310	\$0.49	WASHER, plain		8
54	324-365	\$0.89	WASHER, plain		3	121	310-260	\$0.99	NUT		6
55	365-730	\$0.25	WASHER, locking		3	122	310-275	\$3.99	NUT, long		2
76		NA	HEATSHIELD, carburetors	up to Dec. 1967	1	127	444-375	NA	MANIFOLD, exhaust	1975-'76	1
	372-430	\$24.79	HEATSHIELD, carburetors	from Dec. 1967	1			NA	MANIFOLD, exhaust	1977-'80	1
77	294-500*	\$0.69	GASKET*		6	128	296-690	\$5.49	GASKET, manifold to pipe		1
78	372-375	\$34.99	INSULATING BLOCK		2	135	865-115	\$36.99	PIPE, water pump to inlet manifold rear		1
*Manifold to heatshield, heatshield to insulating block & insulating block to carburettor.						136	635-150	\$2.89	NUT		1
80	411-342	\$13.99	BRACKET, heatshield, front	} approx. Dec 1967 on	1	137	635-160	\$1.39	COMPRESSION SLEEVE		1
81	411-341	\$12.99	BRACKET, heatshield, rear		1	138	635-170	\$8.79	ADAPTOR to water pump		1
82	322-645	\$0.49	BOLT, bracket to heatshield		1	140	328-997	\$1.79	STUD, inlet to exhaust manifold		1
83	310-760	\$0.39	NUT		2	141	365-730	\$0.25	WASHER, locking	} 1975-'76	1
84	324-020	\$0.20	WASHER, locking	2	142	310-140	\$0.24	NUT	1		
					143		NA	BOLT, exhaust to inlet manifold		2	
					144		NA	WASHER, plain		2	
					145	375-480	NA	HEAT SHIELD		1	

LOCAL & OVERSEAS: 805-681-3400  
 FAX: 805-692-2525 www.mossmotors.com



# Exhaust System 948-1098 (10CG)

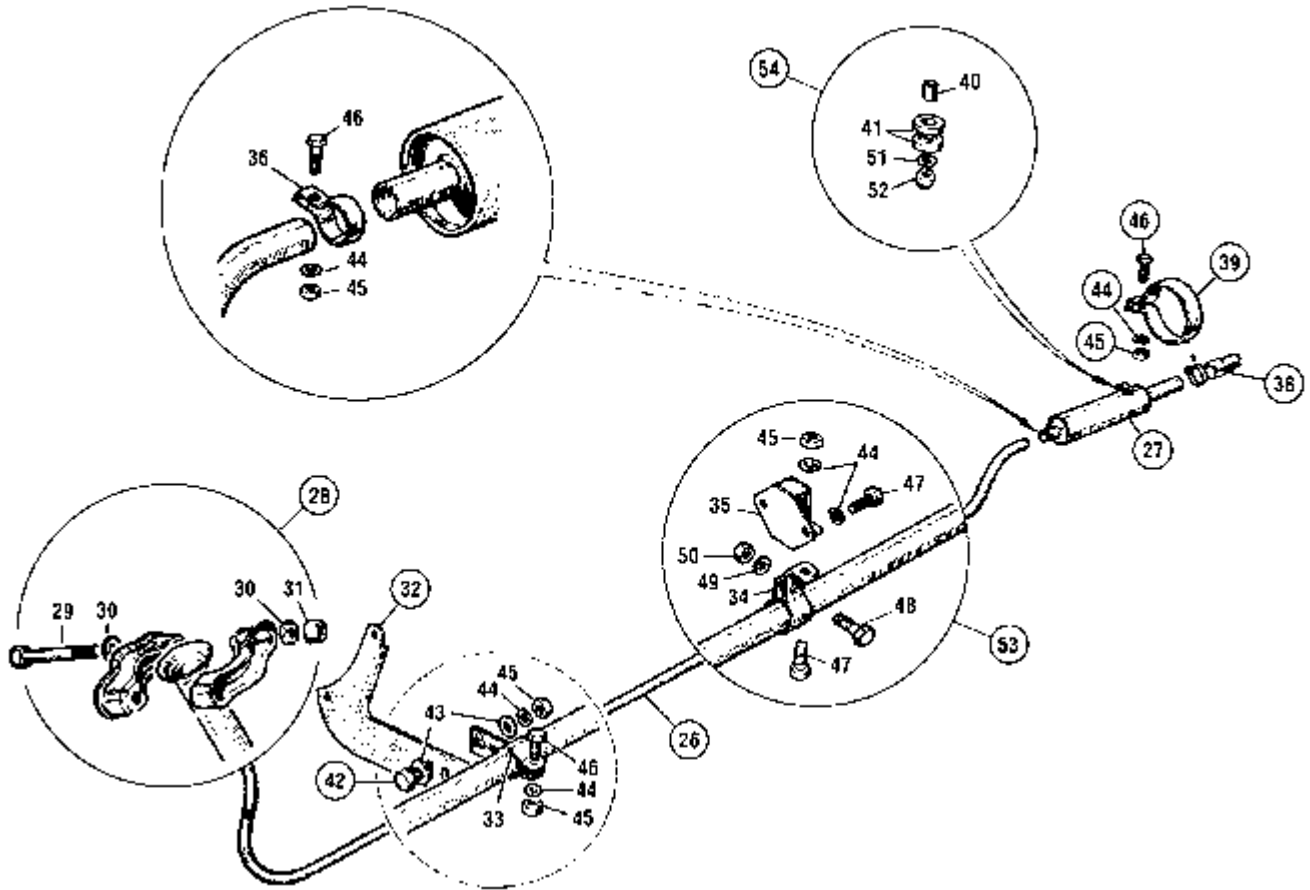

No.	Part No.	Price (each)	Description	Application	Qty. Req.
-----	----------	--------------	-------------	-------------	-----------

## All 948, and 1098 CG engines

Underlined part numbers indicate an Oversize Parts Fee will be charged. See [mossmotors.com](http://mossmotors.com) or call for details.

26	<u>444-220</u>	\$86.99	FRONT PIPE, mild steel		1
27	444-250	\$66.99	MUFFLER, mild steel		1
28	444-200	\$5.89	CLAMP ASSEMBLY, pipe to manifold		1
32	444-369	\$72.99	BRACKET, gearbox steady		1
33	444-366	\$9.79	BRACKET, front pipe to steady bracket		1
34	444-367	\$9.79	BRACKET, front pipe support		1
35	614-008	\$3.59	MOUNT, Exhaust		1
36	444-365	NA	CLAMP, rear, original type		1
	444-385	\$5.99	CLAMP, rear, replacement 'U' bolt type		1
38	444-401	\$12.69	EXTENSION PIPE, (tail pipe)		1
39	NA		CLAMP, (for tail pipe extension)		1
40	444-091	\$1.79	SPACER		1
41	444-280	\$0.69	BUSH, rubber		2
42	322-040	\$0.49	BOLT (5/16")		2
43	365-720	\$0.29	WASHER (5/16")		4
44	365-730	\$0.25	WASHER, spring (5/16")		8
45	310-140	\$0.24	NUT (5/16")		8
46	322-290	\$0.89	BOLT (5/16")		3
47	322-880	\$0.49	BOLT (5/16")		3
48	314-265	\$0.49	BOLT (1/4")		1
49	324-020	\$0.20	WASHER, spring (1/4")		1
50	310-760	\$0.39	NUT (1/4")		1
51	324-155	\$0.39	WASHER, flat (5/16")		1
52	311-005	\$0.89	NUT (5/16")		1
53	444-202	\$15.99	MOUNTING KIT, center		1
54	444-201	\$4.29	MOUNTING KIT, rear		1

## Stainless Steel Exhaust System by Falcon

Guaranteed to be the last exhaust system you'll need for your car. Constructed entirely of top quality stainless steel with proper fit and great sound. Includes everything you need from the manifold flange back except clamps and hangers.  
**948 & 10CG engines     452-000     \$269.99**



The exhaust system will last longer and won't rattle when installed with the proper hangers and hardware. The front brackets are especially important to the longevity of the clamp joint.

MOSS

MOSS MOTORS, LTD.  
TOLL-FREE ORDERS

**1-800-667-7872**

# Exhaust System 1098 (10CC) - 1275

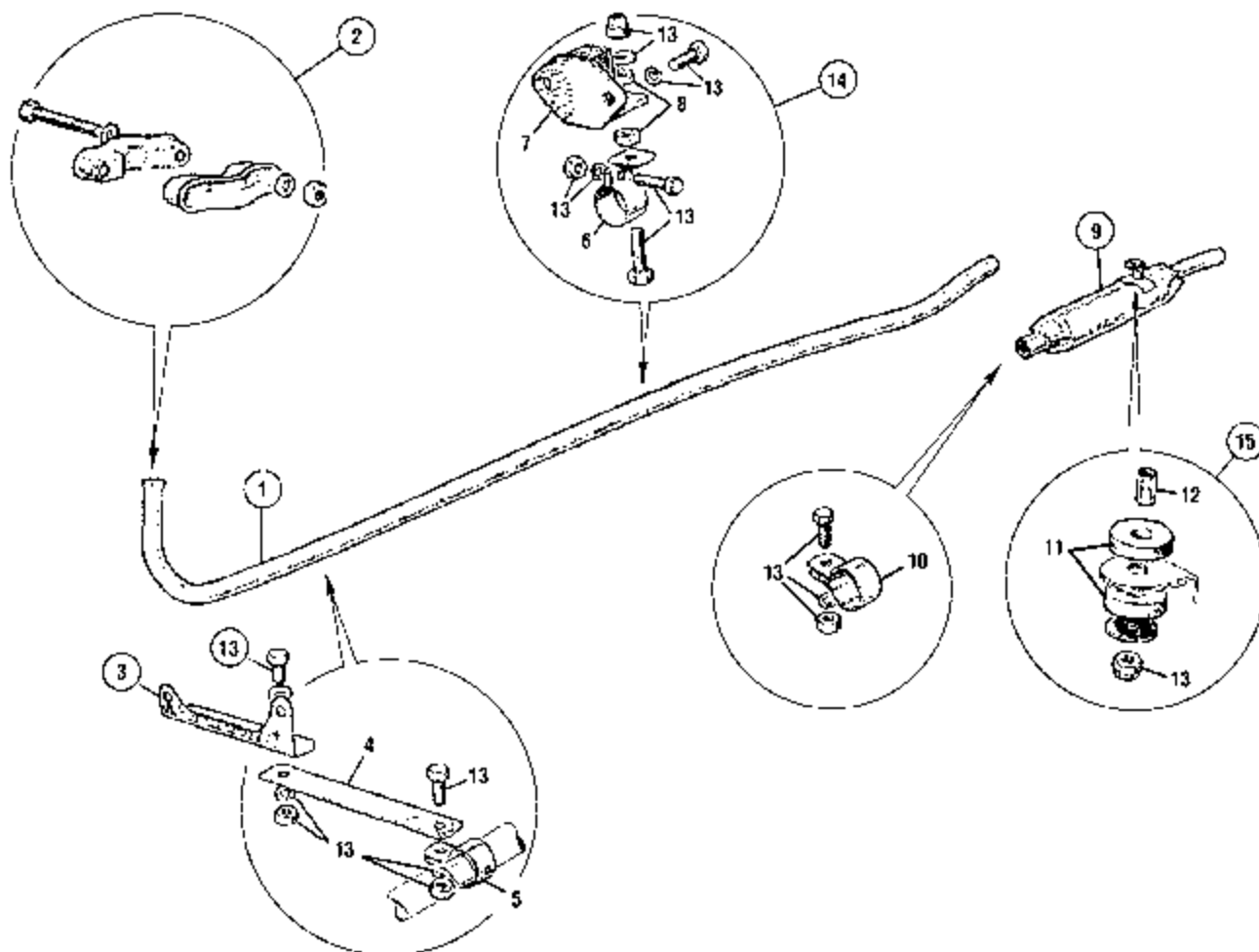

## Stainless Steel Exhaust System by Falcon

Guaranteed to be the last exhaust system you'll need for your car. Constructed entirely of top quality stainless steel with proper fit and great sound. Includes everything you need from the manifold flange back except clamps and hangers.

**10CC & early 1275 engines**     452-010     **\$229.99**

No.	Part No.	Price (each)	Description	Application	Qty. Req.
-----	----------	--------------	-------------	-------------	-----------

### 1098 10CC engines and 1275 clamp style manifold

Underlined part numbers indicate an Oversize Parts Fee will be charged. See [mossmotors.com](http://mossmotors.com) or call for details.

1	<u>444-230</u>	\$57.99	FRONT PIPE, mild steel		1
2	444-210	\$3.49	CLAMP ASSEMBLY, front pipe to manifold		1
3	444-340	\$14.99	BRACKET, gearbox		1
4	444-350	\$5.99	STRAP, front pipe to gearbox		1
5	444-360	\$4.99	CLIP, front pipe to strap		1
6	444-390	\$9.99	CLIP, intermediate		1
7	614-008	\$3.59	MOUNTING, intermediate pipe		1
8	444-090	\$0.99	WASHER/INSULATOR	fits each side of 614-008	2
9	<u>444-260</u>	\$58.99	MUFFLER, mild steel (replacement type with rounded ends)		1
10	411-090	\$6.99	CLIP, front pipe to silencer		1
11	444-280	\$0.69	BUSH, rubber		2
12	444-091	\$1.79	SPACER		1
13	444-208	\$4.79	HARDWARE SET, exhaust mounting (all bolts, nuts and lockwashers for hangers and straps)		1
14	444-203	\$18.99	MOUNTING KIT, center		1
15	444-201	\$4.29	MOUNTING KIT, rear		1

The exhaust system will last longer and won't rattle when installed with the proper hangers and hardware. The front brackets are especially important to the longevity of the clamp joint.

# Exhaust System 1275 - 1500

## 1275 1968-1969

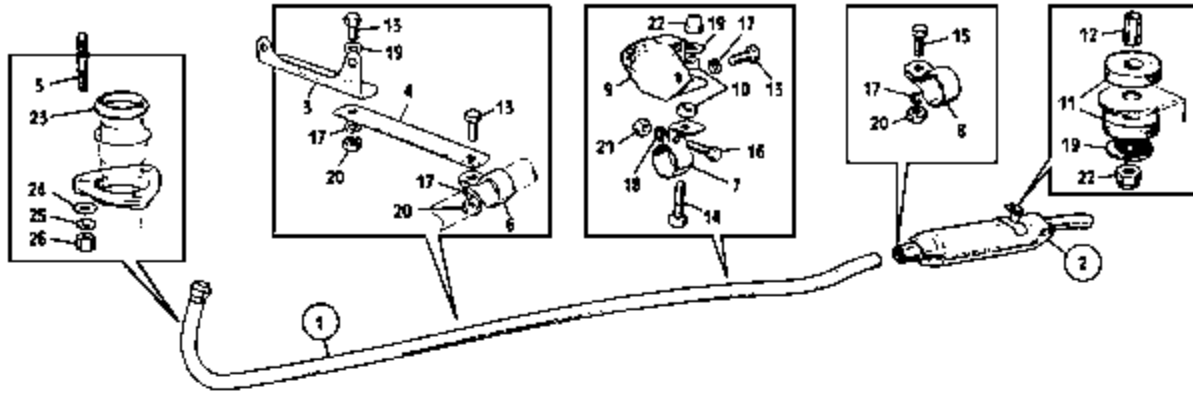

## 1275 1970-1974

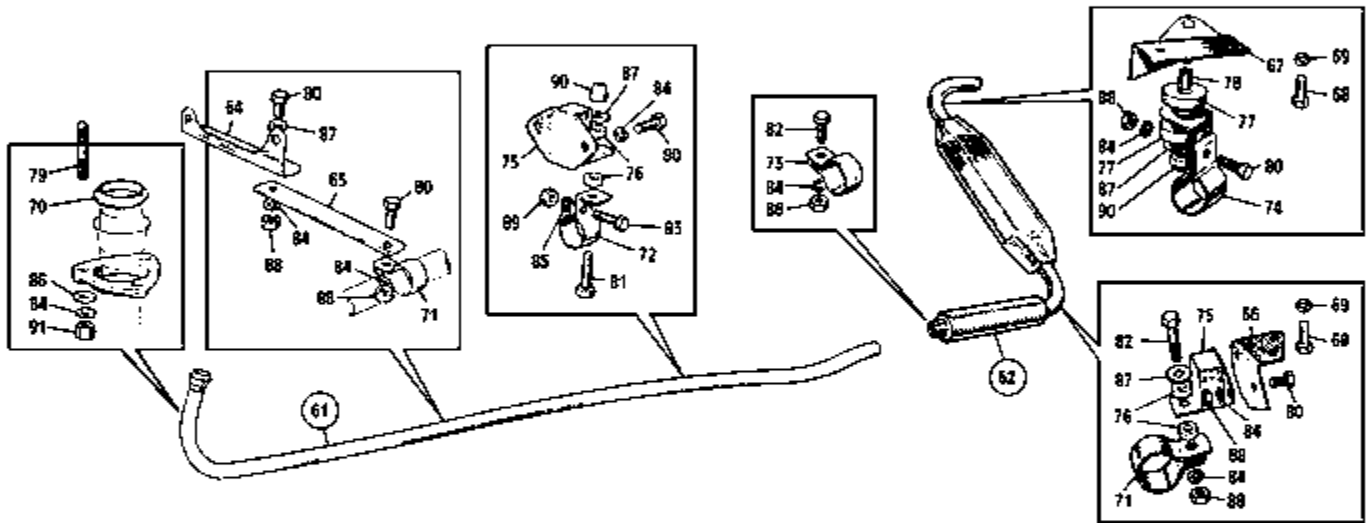

## 1500 1975-1980

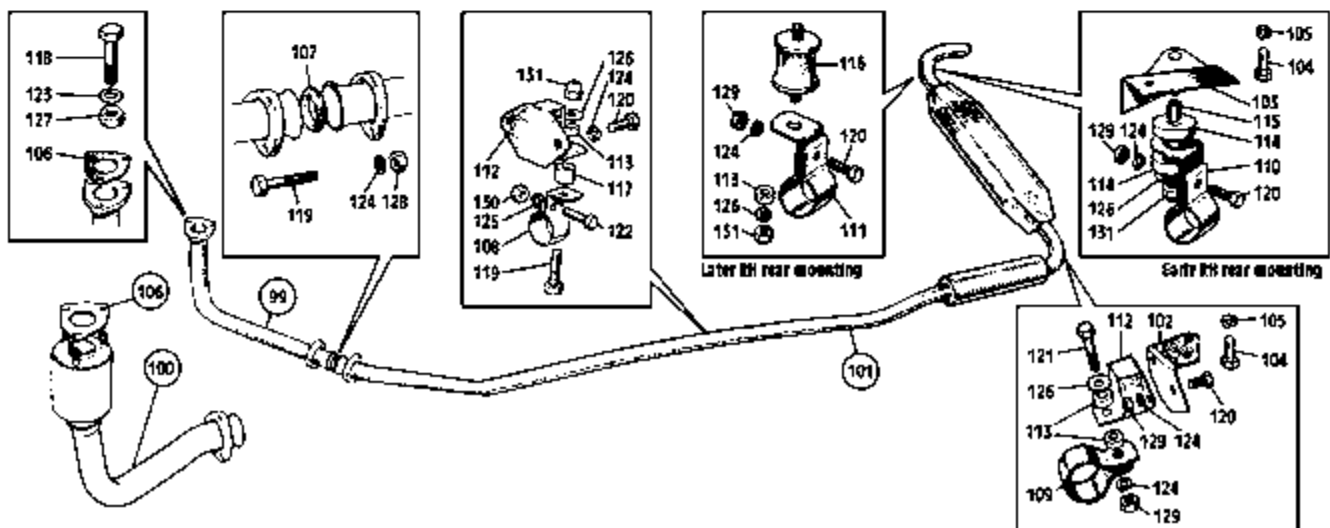



# Exhaust System 1275 - 1500

No.	Part No.	Price (each)	Description	Application	Qty. Req.
-----	----------	--------------	-------------	-------------	-----------

## 1275 1968-1969

North American LHD Specification, 1968-1969

Underlined part numbers indicate an Oversize Parts Fee will be charged. See [mossmotors.com](http://mossmotors.com) or call for details.

1	<u>444-240</u>	\$69.99	FRONT PIPE, mild steel		1
2	<u>444-260</u>	\$58.99	MUFFLER, mild steel		1
3	444-340	\$14.99	BRACKET, gearbox		1
4	444-350	\$5.99	STRAP, bracket to front pipe		1
5	328-765	\$1.09	STUD, manifold		3
6	444-360	\$4.99	CLAMP, front pipe to strap		1
7	444-390	\$9.99	CLAMP, intermediate mounting		1
8	411-090	\$6.99	CLAMP, system joint		1
9	614-008	\$3.59	MOUNTING, intermediate		1
10	444-090	\$0.99	WASHER, insulation		2
11	444-280	\$0.69	BUSH, rubber		2
12	444-091	\$1.79	DISTANCE TUBE		1
13	322-540	\$0.69	BOLT (5/16" UNF x 7/8")		4
14	191-915	\$1.39	BOLT (5/16" UNF x 1-1/4")		1
15	310-487	\$0.69	BOLT (5/16" UNF x 1-1/2")		1
16	314-265	\$0.49	BOLT (1/4" UNF x 7/8")		1
17	365-720	\$0.29	WASHER, locking (5/16")		5
18	324-020	\$0.20	WASHER, locking (1/4")		1
19	324-155	\$0.39	WASHER, plain (5/16")		3
20	310-140	\$0.24	NUT (5/16" UNF)		3
21	310-760	\$0.39	NUT (1/4" UNF)		1
22	310-290	\$0.69	NUT (5/16" UNF)		2
23	290-510	\$1.19	SEALING RING, front pipe to manifold		1
24	324-365	\$0.89	WASHER, special, manifold stud		3
25	365-730	\$0.25	WASHER, locking (5/16")		3
26	311-540	\$0.59	NUT, brass		3

## 1275 1970-1974

North American LHD Specification, 1970-1974

This transverse muffler system uses a three stud flanged manifold joint on the front pipe.

Underlined part numbers indicate an Oversize Parts Fee will be charged. See [mossmotors.com](http://mossmotors.com) or call for details.

61	<u>444-240</u>	\$69.99	FRONT PIPE, mild steel		1
62	<u>444-270</u>	\$149.99	MUFFLER ASS'Y & TAILPIPE, mild steel		1
64	444-340	\$14.99	BRACKET, gearbox		1
65	444-350	\$5.99	STRAP, bracket to front pipe		1
66	444-373	\$13.69	BRACKET, LH	thru (c)138800	1
	444-371	\$8.99	BRACKET, LH	from (c)138801 (1974)	1
67	444-374	\$14.99	BRACKET, RH	thru (c)138800	1
	444-372	\$15.99	BRACKET, RH	from (c)138801 (1974)	1
68	322-880	\$0.49	SCREW, brackets to trunk floor		4
69	365-730	\$0.25	WASHER, locking		4
70	290-510	\$1.19	SEALING RING, front pipe to manifold		1
71	444-360	\$4.99	CLAMP, pipe to strap, LH rear mtg.		2
72	444-390	\$9.99	CLAMP, intermediate		1
73	411-090	\$6.99	CLAMP, system joint		1
74	444-400	\$9.99	CLAMP, pipe to RH rear mounting		1
75	614-008	\$3.59	MOUNTING, intermediate LH rear		2
76	444-090	\$0.99	WASHER, insulation		4
77	444-280	\$0.69	BUSH, rubber		2
78	444-091	\$1.79	DISTANCE TUBE		1
79	328-765	\$1.09	STUD, manifold		3
80	322-540	\$0.69	BOLT (5/16" UNF x 7/8")		7
81	191-915	\$1.39	BOLT (5/16" UNF x 1-1/4")		1
82	310-487	\$0.69	BOLT (5/16" UNF x 1-1/2")		2
83	314-265	\$0.49	BOLT (1/4" UNF x 7/8")		1
84	365-730	\$0.25	WASHER, locking (5/16")		12
85	324-020	\$0.20	WASHER, locking (1/4")		1
86	324-365	\$0.89	WASHER, special, manifold stud		3
87	324-155	\$0.39	WASHER, plain (5/16")		4
88	310-140	\$0.24	NUT (5/16" UNF)		7
89	310-760	\$0.39	NUT (1/4" UNF)		1
90	310-290	\$0.69	NUT, nyloc (5/16" UNF)		2
91	311-540	\$0.59	NUT, brass		3

No.	Part No.	Price (each)	Description	Application	Qty. Req.
-----	----------	--------------	-------------	-------------	-----------

## 1500 1975-1980

Underlined part numbers indicate an Oversize Parts Fee will be charged. See [mossmotors.com](http://mossmotors.com) or call for details.

99	444-290	\$61.99	DOWN PIPE, mild steel	cars w/o Cat. Converter	1
100	444-310	\$309.99	DOWN PIPE, with converter	(not legal in California)	1
101	<u>444-315</u>	\$199.99	PIPE & MUFFLER ASSEMBLY, mild steel (2-piece assembly slips together)		1
102	444-371	\$8.99	BRACKET, LH rear mtg. to trunk floor		1
103	444-372	\$15.99	BRACKET, RH rear mtg. to trunk floor		1
104	322-880	\$0.49	SCREW, bracket to trunk floor		4
105	365-730	\$0.25	WASHER, locking		4
106	296-690	\$5.49	GASKET, manifold to down pipe		1
107	444-130	\$2.89	GASKET, down pipe to rear pipe		1
108	444-390	\$9.99	CLAMP, intermediate mounting		1
109	444-360	\$4.99	CLAMP, pipe to LH rear mounting		1
110	444-400	\$9.99	CLAMP, pipe to RH rear mounting		1
111	310-261	\$9.99	CLAMP, pipe to RH rear mounting		1
112	614-008	\$3.59	MOUNTING, intermediate LH rear		2
113	444-090	\$0.99	WASHER, insulation		3
114	444-280	\$0.69	BUSH, rubber		2
115	444-091	\$1.79	DISTANCE TUBE		1
116	444-080	\$2.89	MOUNTING, RH, clamp to trunk floor		1
117	310-262	\$3.99	SPACER		1
118	322-075	\$0.89	BOLT (3/8" UNF x 1-1/2")		3
119	322-105	\$0.99	BOLT (5/16" UNF x 1-7/8")		4
120	322-540	\$0.69	BOLT (5/16" UNF x 3/4")		5
121	310-487	\$0.69	BOLT (5/16" UNF x 1-1/2")		1
122	314-265	\$0.49	BOLT (1/4" UNF x 7/8")		1
123	324-040	\$0.29	WASHER, locking (3/8")		3
124	365-730	\$0.25	WASHER, locking (5/16")		9
125	324-020	\$0.20	WASHER, locking (1/4")		1
126	324-155	\$0.39	WASHER, plain		3
127	328-651	\$0.89	NUT, special	manifold to down pipe	3
128	311-535	\$4.19	NUT, special	down pipe to exhaust	3
129	310-140	\$0.24	NUT (5/16" UNF)		1
130	310-760	\$0.39	NUT (1/4" UNF)		4
131	310-290	\$0.69	NUT, nyloc, (5/16" UNF)		2



1500 system illustrated.

## Stainless Steel Exhaust Systems by Falcon

Guaranteed to be the last exhaust system you'll need for your car. Constructed entirely of top quality stainless steel with proper fit and great sound. Includes everything you need from the manifold flange back except clamps and hangers.

Sprite/Midget mid 1275 ('68-'69 w/flanged headpipe/straight muffler) . . .	<u>452-015</u>	\$246.99
Midget late 1275 ('70-'74 w/flanged headpipe/transverse muffler) . . .	452-025	NA
(Not available. Earlier straight muffler system 452-015 may be used.)		
Midget 1500 . . . . .	452-030	\$449.99

# Clutch

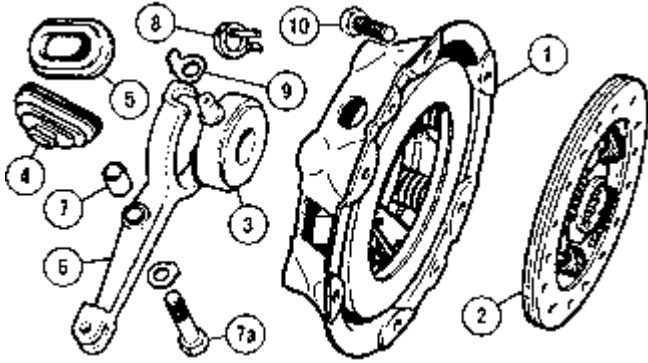

No.	Part No.	Price (each)	Description	Application	Qty. Req.
<b>948 - 1098 - 1275 Clutch</b>					
	190-960	\$309.99	CLUTCH KIT, AP brand	} 948	1
	190-963	\$99.99	CLUTCH KIT, Premium aftermarket		1
	190-970	\$339.99	CLUTCH KIT, AP brand	} 1098	1
	190-971	\$154.99	CLUTCH KIT, "Powertune"		1
	190-972	\$199.99	CLUTCH KIT, aftermarket		1
	190-980	NA	CLUTCH KIT, AP brand	} 1275	1
	190-986	\$114.99	CLUTCH KIT, Premium aftermarket		1
1	190-830	NA	PRESSURE PLATE	948	1
	501-025	\$94.99	PRESSURE PLATE	1098	1
	190-850	\$149.99	PRESSURE PLATE	1275	1
2	190-870	\$59.69	CLUTCH DISC	948, 6 1/4"	1
	190-880	\$59.99	CLUTCH DISC	1098, 7 1/4"	1
	190-890	\$55.99	CLUTCH DISC	} 1275, 6 1/2"	1
	190-891	\$289.99	CLUTCH DISC, uprated (not in kits)		1
3	190-910	\$15.99	RELEASE BEARING	948	1
	190-915	\$19.99	RELEASE BEARING	1098	1
	190-920	\$18.49	RELEASE BEARING	1275	1
4	461-010	\$1.69	BOOT, clutch lever		1
5	461-870	\$6.99	COVER, dust	948, 1098 & 1275	1
6		NA	LEVER, clutch release	948	1
	190-955	\$96.99	LEVER, clutch release	1098 & 1275	1
7	330-435	\$4.19	BUSH	all	1
7a	330-505	\$7.79	BOLT, clutch release fork	all	1
8	190-310	\$1.69	CLIP, release bearing	948	2
9	190-315	\$1.19	CLIP, release bearing	1098 & 1275	2
10	322-040	\$0.49	BOLT, clutch to flywheel	all	6
	324-030	\$0.39	LOCKWASHER for clutch bolt	all	6

NOTE: for early cars fitted with the later ribcase gearbox, use the release bearing appropriate for the engine actually used.



387-320	\$2.89	CLUTCH ALIGNMENT TOOL	948 - 1275	1
387-330	\$2.89	CLUTCH ALIGNMENT TOOL	Midget 1500	1

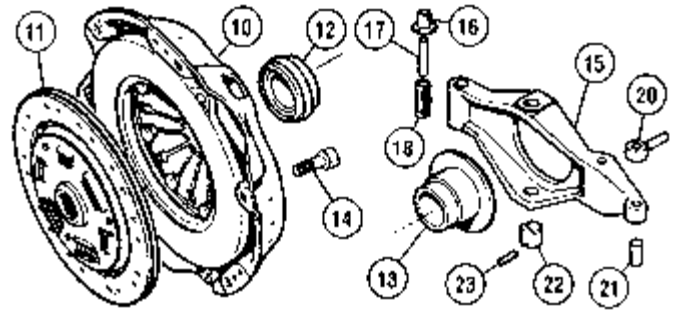

No.	Part No.	Price (each)	Description	Application	Qty. Req.
<b>1500 Clutch</b>					
	190-990	\$149.99	CLUTCH KIT, Borg & Beck		1
	190-993	\$109.99	CLUTCH KIT, aftermarket		1
10	190-860	\$114.99	PRESSURE PLATE, new		1
11	190-900	\$66.99	CLUTCH DISC, new		1
12	190-925	\$24.89	RELEASE BEARING		1
13	190-945	NA	SLEEVE, release bearing		1
14	323-252	\$0.59	SETSCREW, clutch to flywheel (allen head)		6
15	190-950	NA	ARM		1
16	330-445	\$4.59	BUSH, in bell housing		2
17	190-930	\$2.39	RELEASE ARM PIN		1
18	330-455	\$10.89	RELEASE ARM BUSH		1
20	190-935	\$5.99	PUSH ROD		1
21	190-940	\$3.99	PIN, push rod to arm		1
22	328-625	\$7.89	PLUG, sleeve to arm		1
23	329-890	\$0.49	PIN in plug		1



## Clutch Hydraulic Kits

Save money and make ordering easy with this kit, which includes all usually replaced clutch hydraulic components: master cylinder, slave cylinder with pushrod, hose, copper washers and required hardware.

Sprite/Midget 1275	180-668	\$51.99
Midget 1500	180-708	\$66.99

Brake fluid and brake service tools are listed in the color section at the front of this catalog.

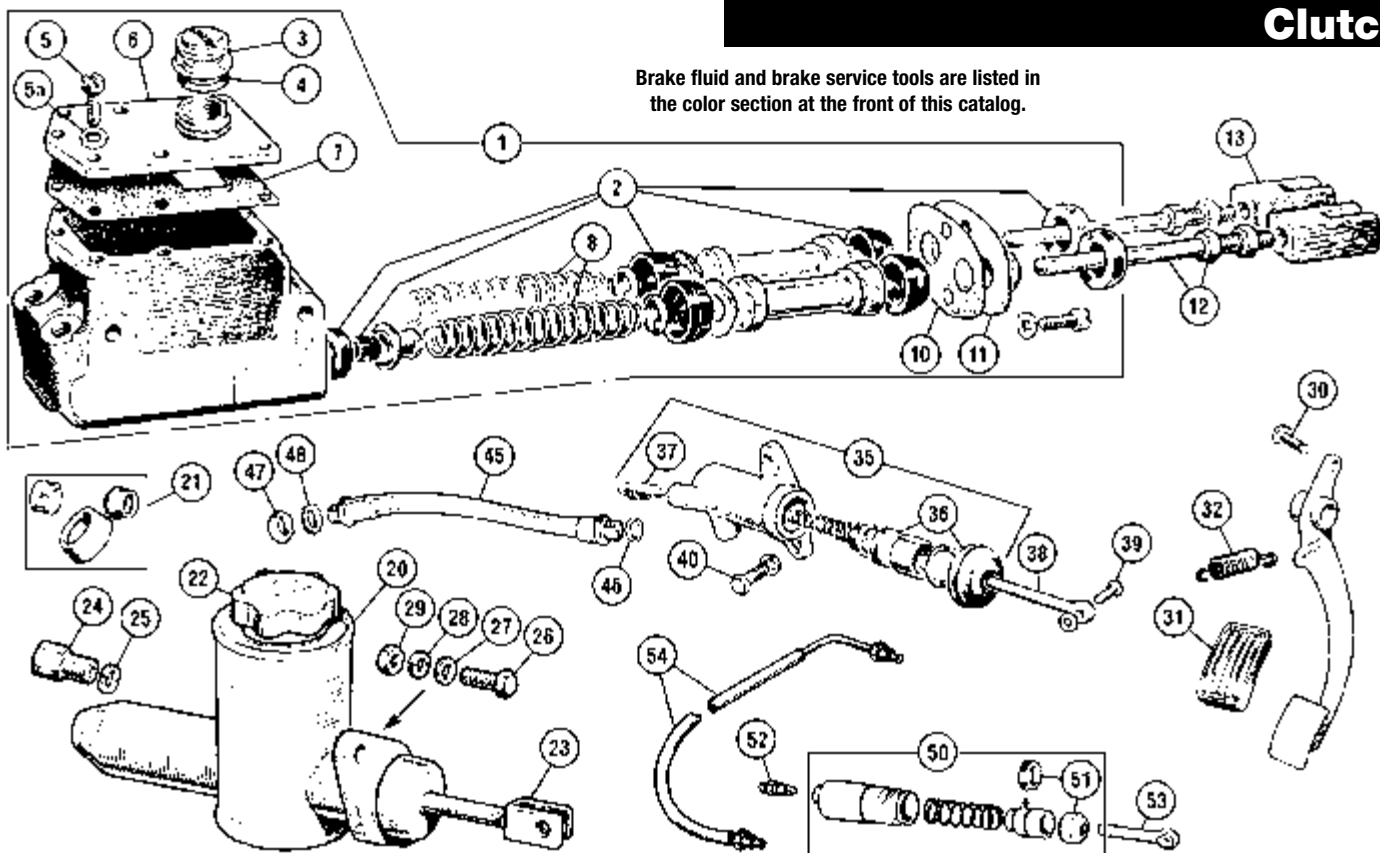

No.	Part No.	Price (each)	Description	Application	Qty. Req.	
<b>Clutch Hydraulics</b>						
1	180-672	\$239.99	MASTER CYLINDER, 7/8", AP Braking	} 948 drum brakes	1	
	180-670	\$104.99	MASTER CYLINDER, 7/8", TRW		1	
	180-673	\$69.99	MASTER CYLINDER, 7/8", Classic Gold		1	
	180-555	\$163.99	MASTER CYLINDER, 3/4", TRW		1098 front disc brakes	1
2	180-971*	\$44.99	REPAIR KIT, 7/8", AP Braking		} 948	1
	180-970*	\$9.99	REPAIR KIT, 7/8", aftermarket	1		
	180-565*	\$11.79	REPAIR KIT, 3/4", aftermarket	1098		1
* These repair kits may include either a replacement type brake cylinder check valve, or the original type rubber cup for the original check valve.						
3	180-210	\$4.49	CAP, plastic replacement	} 948 & 1098	1	
	180-211	\$14.79	CAP, metal (as original)		1	
4	180-451	\$2.99	WASHER, cap (metal caps)		1	
5	323-500	\$0.99	SCREW, front & top covers		9/7	
5a	462-385	\$0.19	LOCKWASHER	9/7		
6	180-275	\$12.99	COVER	1		
7	180-270	\$1.49	GASKET	1		
8	180-030	\$4.79	SPRING	948	2	
	181-710	NA	SPRING	1098	2	
10	180-020	\$1.39	GASKET	} 948 & 1098	1	
11	180-010	NA	PLATE		2	
12	180-305	\$11.89	PUSH ROD, drum brakes, 4-1/8"		2	
13	180-315	\$6.99	PUSH ROD, disc brakes, 3-11/16"	FORK	2	
20	180-624	\$159.99	MASTER CYLINDER, metal reservoir	} Lockheed	1	
	180-627	\$36.99	MASTER CYLINDER, plastic reservoir		1	
21	180-925	\$5.99	REPAIR KIT, cyls. not marked †	} original master cylinders only	1	
	180-915	\$5.79	REPAIR KIT, cyls. marked-see illus. showing marks below †		1	
			illus. showing marks below †		1	
22	180-210	\$4.49	CAP (orig. cyls. only)	} 1275 & 1500	1	
23	180-605	\$18.99	PUSH ROD		1	
24	180-400	\$12.89	ADAPTOR, pipe to master cylinder		1	
25	324-730	\$0.39	WASHER, pipe to master cylinder		1	
26	322-540	\$0.69	BOLT, master cylinder mounting		2	
27	365-720	\$0.29	WASHER		2	
28	365-730	\$0.25	LOCKWASHER		2	
29	310-140	\$0.24	NUT		2	
30	325-150	\$1.09	CLEVIS PIN		all	1
31	280-930	\$1.49	PEDAL PAD, brake & clutch		all	1
32	180-335	\$3.29	SPRING, pedal return		948 & 1098	2
	329-350	\$1.99	SPRING, pedal return		1275 & 1500	2

No.	Part No.	Price (each)	Description	Application	Qty. Req.
35	180-655	\$72.99	SLAVE CYLINDER, 7/8" bore, Lockheed	} 948 & 1098	1
	180-657	\$13.99	SLAVE CYLINDER, 7/8" bore, aftermarket		1
	180-665	\$126.99	SLAVE CYLINDER, 1" bore, Lockheed		1
	180-667	\$14.19	SLAVE CYLINDER, 1" bore, aftermarket	} 1275	1
36	180-935	\$3.69	REPAIR KIT	948 & 1098	1
	180-945	\$7.19	REPAIR KIT	1275	1
37	180-100	\$1.39	BLEEDER SCREW	948 - 1098	1
38	180-200	\$2.69	PUSH ROD, 2 3/8" *	} 1275	1
	180-595	\$4.29	PUSH ROD, 2 11/16" *		1
39	582-590	\$0.79	CLEVIS PIN	948-1275	1
40	116-162	\$1.69	BOLT, slave cyl. mounting	} 948-1275	2
NOTE: 948 and 1098 cars used a pipe from the master cylinder to the slave cylinder. These cars did not use a hose in the clutch system.					
	588-025	\$32.49	PIPE, master cyl. to slave cyl.	948 - 1098	1
	180-606	\$31.29	PIPE, master cylinder to hose	} 1275	1
45	180-820	\$20.99	HOSE		1
	180-821	\$8.79	HOSE, aftermarket		1
	180-823	\$22.99	HOSE, stainless steel braided, "Cobalt"		1
46	324-720	\$0.79	COPPER WASHER	1	
47	311-420	\$1.79	NUT	1	
48	324-180	\$0.39	LOCK WASHER	1	
50	180-705	\$14.69	SLAVE CYLINDER, Classic Gold	} 1500	1
51	180-955	\$7.89	REPAIR KIT		1
52	180-080	\$2.99	BLEEDER SCREW		1
53	190-935	\$5.99	PUSH ROD, 3 1/16" *		1
54	180-845	\$18.59	HOSE & PIPE ASS'Y.	1	

\* Dimensions given are from hole center to end.

† Note: From 1968 to '80, either one of two master cylinders was fitted. One is identified by either of the markings shown below. The other has no such markings. The master cylinder assemblies are interchangeable, but the internal parts are not.

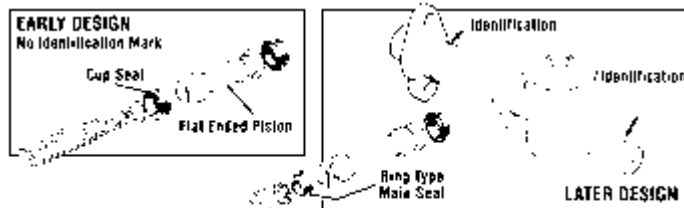

**LOCAL & OVERSEAS: 805-681-3400**  
**FAX: 805-692-2525** [www.mossmotors.com](http://www.mossmotors.com)

**MOSS**



# External Gearbox 948-1275

No.	Part No.	Price (each)	Description	Application	Qty. Req.	No.	Part No.	Price (each)	Description	Application	Qty. Req.
1	427-520	\$999.99	GEARBOX, rebuilt (w/o shifter housing)	1098, 1275	1	85	462-465	\$0.69	WASHER, sealing		1
		\$600.00	CORE CHARGE FOR 427-520			86		NA	SHAFT, control	948	1
2	297-700	\$4.99	GASKET SET		1			NA	SHAFT, control	1098, 1275	1
3	325-080	\$1.49	DOWEL, upper	948, 1098	1	87		NA	LEVER, control	948	1
3	116-151	NA	DOWEL, upper	1275	1			NA	LEVER, control	1098, 1275	1
4	325-080	\$1.49	DOWEL, lower		1	88	462-550	NA	SCREW, lever to shaft		1
5	320-695	\$0.69	BOLT, gearbox to engine plate	948	8	89	324-020	\$0.20	WASHER, locking		1
5	320-070	\$0.89	BOLT, gearbox to engine plate	1098, 1275	8	90		NA	SHAFT, remote control	948	1
6	365-730	\$0.25	WASHER, locking		3			NA	SHAFT, remote control	1098, 1275	1
7	310-140	\$0.24	NUT		8	91	327-200	\$0.39	KEY		2
8	322-620	\$0.69	BOLT		2	92		NA	LEVER, selector, front		1
9	324-040	\$0.29	WASHER, locking		2	93	322-247	\$0.49	SCREW, pinch		1
10	310-050	\$0.59	NUT		2	94	324-020	\$0.20	WASHER, locking		1
15		NA	COVER, front	948	1	95	461-826	NA	BUSH, front selector lever		1
	461-765	\$259.99	COVER, front, repl., w/ lip type oil seal	} 1098, 1275	1	96		NA	LEVER, selector, rear		1
	461-766	\$6.39	OIL SEAL (replacement) for 461-765		1	97		NA	SCREW, pinch		1
17		NA	STUD, cover to gearbox		7	98	324-020	\$0.20	WASHER, locking		1
18	324-020	\$0.20	WASHER, locking		7	100	441-610	NA	PLUNGER, reverse protection	948 thru 1275 to GAN4-58111	1
19	310-760	\$0.39	NUT		7			NA	PLUNGER, reverse protection	1275 from GAN4-58112	1
25		NA	SIDE COVER		1	101	329-270	NA	SPRING, plunger	948 thru 1275 to GAN4-58111	1
27		NA	STUD, side cover to gearbox		8			NA	SPRING, plunger	1275 from GAN4-58112	1
28	324-020	\$0.20	WASHER, locking		8	102	461-720	NA	PIN, plunger locating		1
29	310-760	\$0.39	NUT		8	105	329-520	\$0.49	BALL, reverse selector		1
30	848-760	NA	COVER, starter pinion		1	106	329-240	\$2.79	SPRING, ball		1
31	725-070	\$1.99	SCREW, cover to gearbox		3	107		NA	PLUG, reverse selector ball		1
32	324-020	\$0.20	WASHER, locking		3	108	462-440	\$2.39	PLUNGER, control shaft damping		1
33	461-870	\$6.99	COVER, dust		1	109	329-010	\$0.59	SPRING, plunger		1
34	461-010	\$1.69	BOOT, clutch lever		1	110	462-445	NA	PLUG, control shaft damper		1
35	461-875	\$3.29	DUST COVER, side		1	111	324-770	\$1.39	WASHER, copper		1
36	328-055	\$7.99	PLUG, oil drain		1	112	329-520	\$0.49	PLUNGER, reverse detent	} late 1275	1
	328-056	\$32.99	PLUG, oil drain, magnetic (optional)		1	113	462-490	NA	PLUG, reverse detent plunger		1
37		NA	SCREW, reverse shaft locating		1	115		NA	GEAR LEVER (several variations)	1	
38	324-020	\$0.20	WASHER, locking		1	116		NA	COVER, gear lever seat	1	
40	330-550	\$9.79	BUSH, rear mainshaft		1	117	322-645	\$0.49	SCREW, cover	} 948, 1098, & 1275 thru 1969	3
			Note: Bush must be reamed or honed to fit yoke spindle after installation.			118	324-020	\$0.20	WASHER, locking		1
41	120-920	\$4.99	OIL SEAL, rear		1	119		NA	COVER, remote housing	1	
43	314-265	\$0.49	BOLT, rear extension to gearbox		9	120	314-200	\$0.29	SCREW, cover to gearbox tunnel	4	
44	324-020	\$0.20	WASHER, locking		9	121	680-890	\$5.79	GROMMET, gear lever	1	
45	461-810	\$259.99	PINION, speedo drive		1	125		NA	GEAR LEVER	1	
46	461-440	NA	PINION HOUSING		1	126		NA	COVER, gear lever seat	1	
47	461-445	\$2.49	OIL SEAL, speedo pinion		1	127		NA	PLATE	1	
48	461-460	NA	RING, oil seal retaining		1	128	322-645	\$0.49	SCREW	} 1275 1970-74	3
49	324-820	\$4.99	SEALING WASHER (copper)	late 1275	1	129	324-020	\$0.20	WASHER, locking		1
53		NA	STUD, long		6	130		NA	SUPPORT, gear lever boot	1	
54		NA	STUD, short		2	131	462-780	\$14.99	BOOT, gear lever	1	
55	365-730	\$0.25	WASHER, locking		8	132		NA	RING, boot & support to gearbox tunnel	1	
56	310-140	\$0.24	NUT		8	133	314-045	\$0.29	SCREW, ring to gearbox tunnel	4	
59	322-170	\$0.49	SCREW, lower cover		4	135	462-770	NA	SHIFT KNOB (use 462-775)	948	1
60	324-020	\$0.20	WASHER, locking		4	136	462-775	\$11.79	SHIFT KNOB	1098, 1275 thru 1971	1
61		NA	CORE PLUG, shifter housing		2	136	462-785	NA	SHIFT KNOB	1275, 1972-74	1
62	141-020	\$31.99	SWITCH, reverse lights	1275	1	140	462-850	\$14.99	ANTI-RATTLE KIT, shift lever (Includes nos. 108, 109,141-143)	1	
63	435-567	\$1.19	WASHER, copper	1275	1	141	290-955	\$0.39	RING	1	
65		NA	ROD, reverse selector	948	1	142	461-825	\$8.49	BUSH	1	
	461-845	NA	ROD, reverse selector	1098, 1275	1	143	329-195	\$3.89	SPRING	1	
66	461-880	NA	FORK, reverse selector	all	1	145	462-550	NA	PEG, gear lever locating	1	
67		NA	ROD, 3rd/4th selector	948	1	146	324-020	\$0.20	WASHER, locking	1	
	461-855	NA	ROD, 3rd/4th selector	1098, 1275	1						
68		NA	FORK, 3rd/4th selector	948	1						
	461-890	NA	FORK, 3rd/4th selector	1098, 1275	1						
69		NA	ROD, 1st/2nd selector	948	1						
	461-865	NA	ROD, 1st/2nd selector	1098, 1275	1						
70		NA	FORK, 1st/2nd selector	948	1						
	461-885	\$52.49	FORK, 1st/2nd selector	1098, 1275	1						
71	461-760	\$3.79	SCREW, locating fork on rod		3						
72	365-740	\$0.49	NUT, locking		3						
73	462-385	\$0.19	WASHER, locking		3						
75		NA	PLUNGER, interlock		1						
76	329-520	\$0.49	BALL, interlock		2						
78		NA	PLUG, interlock ball		1						
79	462-465	\$0.69	WASHER, sealing		1						
80	462-185	NA	PLUNGER, 1st/2nd & 3rd/4th		2						
81	462-460	\$0.59	SPRING, plunger		2						
82	462-185	NA	PLUNGER, reverse		1						
83	329-240	\$2.79	SPRING, plunger	948, 1098	1						
83	462-460	\$0.59	SPRING, plunger	1275	1						
84	848-790	NA	PLUG, reverse selector plunger		1						



# Internal Gearbox 948-1275

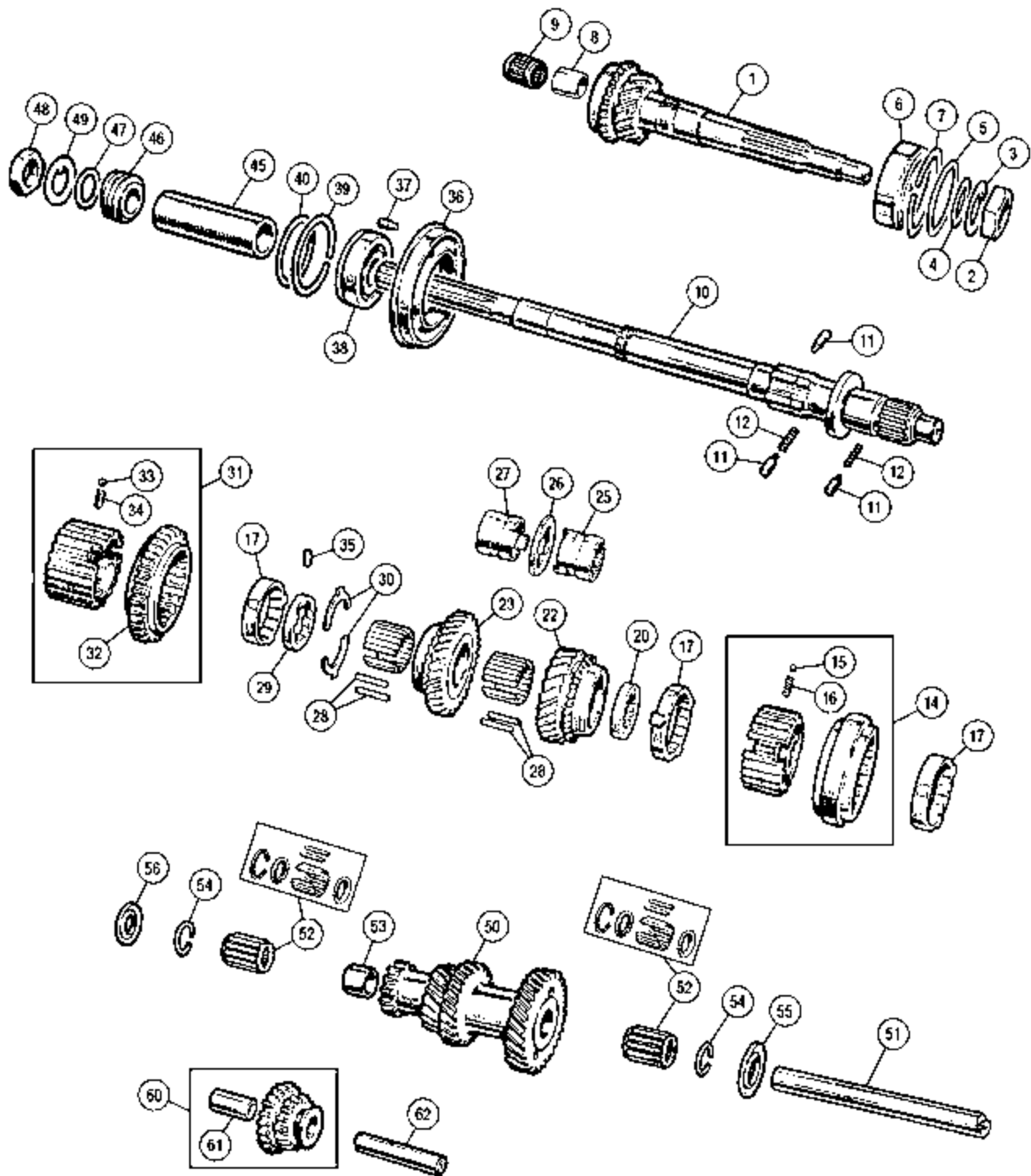

# Internal Gearbox 948-1275

No.	Part No.	Price (each)	Description	Application	Qty. Req.
Gearbox applications follow the original engines to which they were fitted.					
1	461-910	NA	INPUT SHAFT (several variations)	948, 1098	1
2	311-315	\$0.39	NUT, input shaft	1275	1
3	461-806	\$5.99	LOCK TAB		1
4	NA	NA	WASHER, plain		1
5	461-975	\$1.59	SHIM, .004"		A/R
	461-980	\$1.99	SHIM, .006"		A/R
	461-985	\$1.89	SHIM, .010"		A/R
6	127-040	\$29.99	BEARING, input shaft		1
7	NA	NA	CIRCLIP, bearing		1
8	330-600	\$5.89	BUSHING, input to mainshaft	9C gearbox	1
9	127-030	\$4.89	BEARING, input shaft to mainshaft	9CG thru 1275	1
10	NA	NA	MAINSHAFT (several variations)	948 & 10CG	1
	461-990	NA	MAINSHAFT	10CC & 1275	1
11	461-795	\$14.99	PEG		A/R
12	329-215	NA	SPRING	948	A/R
	NA	NA	SPRING	1098, 1275	3
14	NA	NA	SYNCHRO ASS'Y, 3rd/4th (severals)	948, early 1098	1
	461-965	NA	SYNCHRO ASSEMBLY, 3rd/4th	10CC from (e)H4642, 1275	1
15	329-600	\$0.39	BALL		3
16	NA	NA	SPRING	948	3
	329-305	\$0.89	SPRING	1098, 1275	3
17	461-970	\$25.99	SYNCHRO RING	1098, 1275	3
20	NA	NA	THRUST WASHER, front, (0.212"/0.213")	} 9C gearbox	1
	NA	NA	THRUST WASHER, front, (0.214"/0.215")		1
	NA	NA	THRUST WASHER, front, (0.216"/0.217")		1
	NA	NA	THRUST WASHER, front, (0.218"/0.219")		1
	NA	NA	COLLAR, locking, front	9CG gearbox	1
	NA	NA	COLLAR, locking, front	10CC gearbox	1
	NA	NA	COLLAR, locking, front	10CG & 1275	1
22	NA	NA	GEAR, 3rd (several variations)	948	1
	843-050	\$249.99	GEAR, 3rd	10CG, 10CC to (e)H4641	1
23	NA	NA	GEAR, 2nd	948	1
	843-040	\$52.99	GEAR, 2nd	10CG, 10CC to (e)H4641	1
25	461-785	NA	BUSHING, 3rd gear	} 9C gearbox	1
26	461-786	\$15.99	INTERLOCK		1
27	461-775	\$54.99	BUSHING, 2nd gear		1
28	NA	NA	NEEDLE ROLLER (28 per gear)	9CG gearbox	56
	461-960	\$0.39	NEEDLE ROLLER (26 per gear)	} 1098, 1275	52
29	NA	NA	COLLAR, locking, rear		1
30	NA	NA	THRUST WASHER, locking collar	9CG gearbox	2
	461-835	NA	THRUST WASHER, locking collar	1098, 1275	2
31	NA	NA	GEAR ASSEMBLY, 1st (several variations)	948	1
	NA	NA	GEAR ASSEMBLY, 1st (use with orig laygear 22G76)	10CG, 10CC to (e)H4641	1
	461-950	\$236.99	GEAR ASSEMBLY, 1st	} 10CC from (e)H4642, 1275	1
32	461-945	\$112.99	GEAR, 1st		1
33	329-600	\$0.39	BALL		3
34	NA	NA	SPRING	948	3
	329-305	\$0.89	SPRING	1098, 1275	3
35	NA	NA	PLUNGER	1275	1
36	NA	NA	HOUSING, mainshaft bearing		1
37	461-370	NA	PEG, locating		1
38	127-040	\$29.99	BEARING, mainshaft	948	1
	127-020	\$47.99	BEARING, mainshaft	1098, 1275	1
39	NA	NA	CIRCLIP, bearing		1
40	461-975	\$1.59	SHIM, 0.004"		A/R
	461-980	\$1.99	SHIM, 0.006"		A/R
	461-985	\$1.89	SHIM, 0.010"		A/R
45	NA	NA	DISTANCE TUBE	948	1
	NA	NA	DISTANCE TUBE	1098, 1275	1
46	461-805	\$19.99	DRIVE GEAR, speedometer		1
47	NA	NA	WASHER, plain		1
48	311-315	\$0.39	NUT, mainshaft		1
49	461-806	\$5.99	LOCK TAB		1
50	NA	NA	LAYGEAR (several variations)	948	1
	843-100	NA	LAYGEAR (22G76)	10CG, 10CC to (e)H4641	1
	461-905	\$239.99	LAYGEAR (22G232 / 22G1100)	10CC from (e)H4642, 1275	1
51	461-940	NA	LAYSHAFT, standard		1
	461-942	\$46.99	LAYSHAFT, premium, hardened to 60-62HRC		1
52	127-010	\$4.79	BEARING, caged, laygear (replaces early loose rollers)		2
53	NA	NA	DISTANCE TUBE		1
54	326-990	\$2.49	CIRCLIP, bearing		2

No.	Part No.	Price (each)	Description	Application	Qty. Req.
55	461-915	\$9.99	THRUST WASHER, front		1
56	461-920	\$9.99	THRUST WASHER, rear, 0.123"-0.124"		A/R
56	461-925	\$9.99	THRUST WASHER, rear, 0.125"-0.126"		A/R
56	461-930	\$9.99	THRUST WASHER, rear, 0.127"-0.128"		A/R
56	461-935	\$9.99	THRUST WASHER, rear, 0.130"-0.131"		A/R
	461-937	\$9.99	THRUST WASHER, rear, 0.132"-0.133"		A/R
60	NA	NA	GEAR, reverse idler	948	1
	461-896	\$54.99	GEAR, reverse idler	10CG, 10CC to (e)H4641	1
	461-895	\$73.79	GEAR, reverse idler	10CC from (e)H4642, 1275	1
61	NA	NA	BUSH, reverse idler gear		1
62	461-900	NA	SHAFT, reverse idler		1

Most parts for the 948 "smooth case" transmissions fitted to the Sprite Mk1 & II and Midget Mk1 have been unavailable for many years. Synchros for these transmissions are "shrunk-on" to the gears and must be machined to fit; an expensive operation requiring an experienced machinist. Since the ribcase transmissions are less complex and replacement parts are readily available, we recommend the direct replacement of a troublesome smooth case with the ribcase. An added advantage is the more desirable gear ratios fitted to the late units. (The clutch release lever for the ribcase gearbox, #190-955, must be used. However, you must use the release bearing appropriate for the engine installed.) Eliminating excess free play will do wonders for your clutch action. Since for all practical purposes the clutch is not adjustable, each part must be in top condition. New clevis pins and new slave cylinder push rod are recommended. Slave cylinder rods should not have sections welded to them to make them longer. This is an erroneous repair which is done to avoid installing a new release bearing. Occasionally a rod from another car is substituted.



## 5-Speed Conversion Kits

If you plan on driving your classic, installing a 5 speed transmission will make the car much more enjoyable at highway speeds. Using the popular Ford T9 gearbox, the installation is reversible with minimal modifications to the frame or transmission tunnel. Get better fuel economy, less engine wear and easier shifts. The five speed kits come complete with the following components:

- Reconditioned Ford T9 Gearbox
- New Bellhousing (or adaptor plate on 1500cc models)
- Spigot Bushing
- Clutch Plate
- Clutch Plate Cover
- Clutch Release Bearing
- New Clutch Arm Pivot
- New Propshaft
- Chassis Cross Member and Strengtheners
- Speedometer Cable (Note: Speedo will need to be recalibrated)
- Standard Gear Lever
- Gear Lever Gaiter
- All Bolts and Fasteners
- Detailed Instructions

Sprite/Midget 948	440-145	\$5350.00
Sprite/Midget 1098	440-155	\$5185.00
Sprite/Midget 1275	440-165	\$5185.00
Midget 1500	440-175	\$4995.00
Clutch Alignment Tool	041-620	\$2.89

**LOCAL & OVERSEAS: 805-681-3400**  
**FAX: 805-692-2525** [www.mossmotors.com](http://www.mossmotors.com)



# Gearbox - 1500 Midget

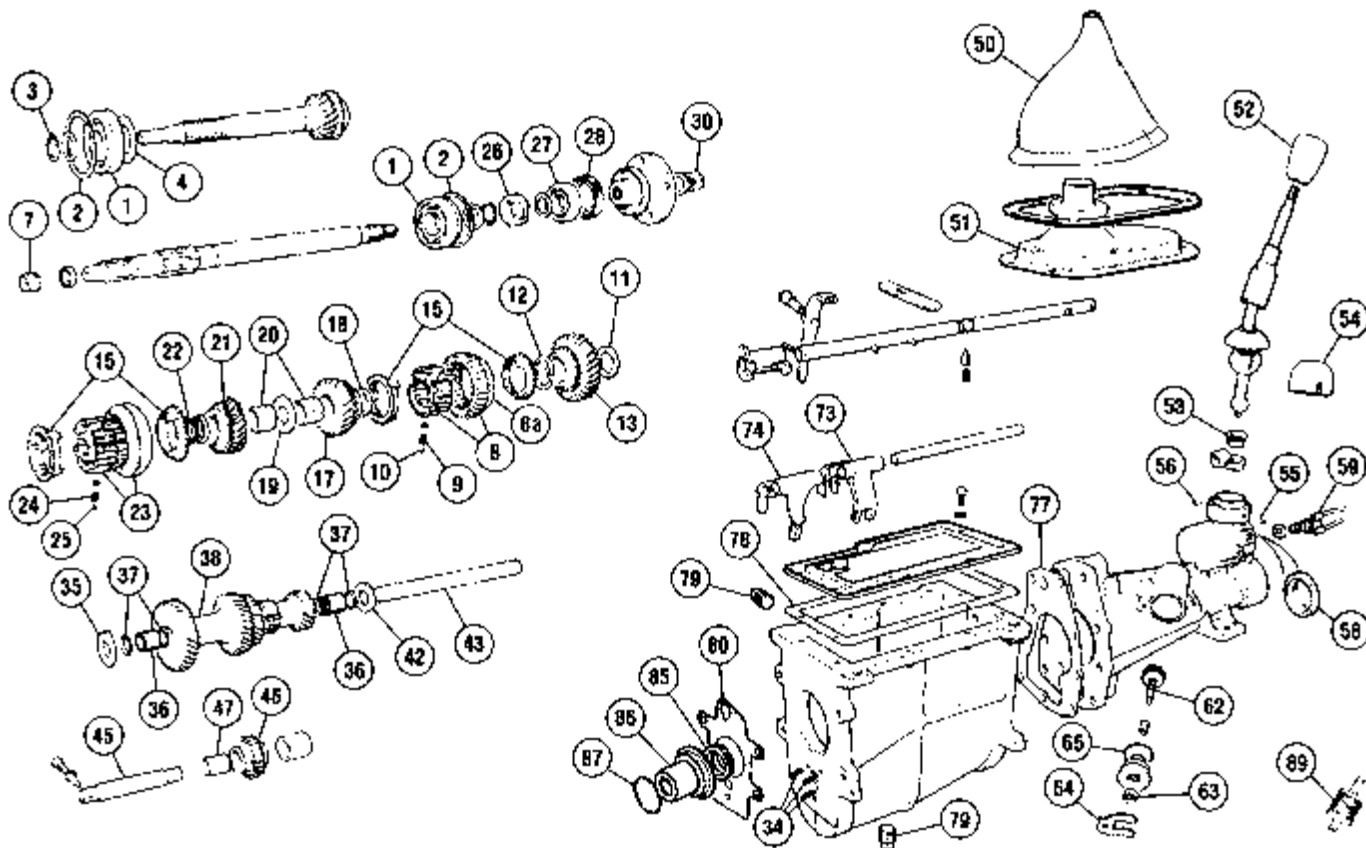

No.	Part No.	Price (each)	Description	Application	Qty. Req.
<b>1500 Gearbox</b>					
	693-060	\$4.29	GASKET SET (includes items marked *)		1
1	071-329	\$17.89	BEARING, input shaft & mainshaft center		2
2	326-745	\$29.99	CIRCLIP, bearing retaining		2
3	326-765	\$0.59	CIRCLIP, input shaft		1
4	848-075	NA	OIL THROWER		1
7	525-190	\$4.19	BEARING, mainshaft spigot		1
8	071-320	NA	SYNCHRO HUB ASS'Y., 1st & 2nd	A - see note below	1
8a	071-342	\$129.99	GEAR, outer	A - see note below	1
	071-321	NA	SYNCHRO HUB ASS'Y., 1st & 2nd	B - see note below	1
9	329-225	\$0.49	SPRING, synchro		3
10	329-510	\$0.39	BALL, synchro		3
11	847-350	NA	THRUST WASHER		1
12	847-475	\$8.99	SPLIT COLLAR, 1st gear		2
13	321-060	\$156.89	1st GEAR		1
15	071-330	\$10.69	SYNCHRO RING		4
17	NA		2nd GEAR		1
18	847-235	NA	THRUST WASHER, 2nd gear		1
19	847-300	NA	THRUST WASHER, .152 - .154"	A/R	
	847-310	\$1.49	THRUST WASHER, .156 - .158"	A/R	
	847-320	NA	THRUST WASHER, .161 - .163"	A/R	
	847-330	NA	THRUST WASHER, .165 - .167"	A/R	
	847-340	NA	THRUST WASHER, .169 - .171"	A/R	
20	847-290	\$29.99	BUSH, 2nd & 3rd gears		2
21	847-460	\$39.99	3rd GEAR		1
22	326-995	\$1.29	CIRCLIP, mainshaft		1
23	847-410	\$129.99	SYNCHRO HUB ASS'Y., 3rd & 4th		1
24	329-475	\$0.69	SPRING, synchro		3
25	329-510	\$0.39	BALL, synchro		3
26	847-270	\$5.99	GEAR, speedo drive		1
27	525-200	\$18.49	BEARING, mainshaft rear		1
28	520-410	\$1.89	OIL SEAL, rear		1
30	310-485	\$1.79	NUT, mainshaft flange		1
34	847-380	\$1.29	SPRING		3
35	847-230	\$7.49	THRUST WASHER, front		1
36	525-210	\$0.24	NEEDLE ROLLERS		50
37	525-205	\$15.99	RING, roller retaining		4
38	847-240	NA	LAYGEAR (15 teeth on rev. gear)	A - see note below	1
	847-220	NA	LAYGEAR (13 teeth on rev. gear)	B - see note below	1
42	847-250	NA	THRUST WASHER, rear		1
43	071-324	\$26.99	LAYSHAFT		1
45	846-130	NA	SPINDLE, reverse idler		1

No.	Part No.	Price (each)	Description	Application	Qty. Req.
46	071-325	\$77.79	REVERSE IDLER GEAR (21 teeth)	A - see note below	1
	071-326	\$81.99	REVERSE IDLER GEAR (17 teeth)	B - see note below	1
47	330-485	NA	BUSH, reverse idler		1
50	681-135	\$16.99	SHIFT BOOT, vinyl		1
51	681-130	NA	SHIFT BOOT, rubber		1
52	847-260	NA	SHIFT KNOB		1
53	NA		BUSH, shift lever	to gearbox #56469	1
	330-580	\$25.99	BUSH, shift lever	from gearbox #56470	1
54	330-585	NA	RETAINER, shift lever		1
55	847-435	\$4.99	PIN, long (L/H side)		1
56	847-430	NA	PIN, short (R/H side)		1
58	848-595	\$1.29	END CAP, shifter housing		1
59	542-410	\$10.99	SWITCH, reverse light		1
62	847-280	\$63.99	PINION, speedo drive	22 teeth, red	1
	847-420	NA	PINION, speedo drive	21 teeth, green	1
	847-285	NA	PINION, speedo drive	20 teeth, orange	1
63	461-445	\$2.49	OIL SEAL, speedo pinion		1
64	072-395	\$4.99	RETAINER, speedo cable		1
65	264-943	\$0.29	"O" RING		1
73	847-390	NA	FORK, 1st & 2nd selector		1
74	847-470	NA	FORK, 3rd & 4th selector		1
77	693-040*	\$0.69	GASKET, gearbox to rear extension		1
78	693-050*	\$1.39	GASKET, top cover		1
79	328-340	\$1.19	PLUG, drain & filler		2
	328-356	\$7.99	DRAIN PLUG, magnetic	(optional)	1
80	693-030*	\$1.39	GASKET, bellhousing to gearbox		1
85	520-240	\$3.79	OIL SEAL, front	when fitted	1
86	848-585	NA	COVER, front		1
87	290-960	\$1.89	O-RING		1
89	810-140	\$2.69	MOUNT, transmission		2

## 1500 Gearbox Notes

To extend gearbox life, British Leyland designed a modified gear set consisting of a new 1st/2nd synchro hub assembly, laygear, and reverse idler gear. Components with the application "A" above were originally fitted up to gearbox #241363, gears above with the application "B" were originally fitted from gearbox #241364. Over the years, many early gearboxes were fitted with the later gears. To avoid confusion, please count your reverse gear teeth before ordering.

MOSS

MOSS MOTORS, LTD.  
TOLL-FREE ORDERS

1-800-667-7872



# Differential / Driveshaft

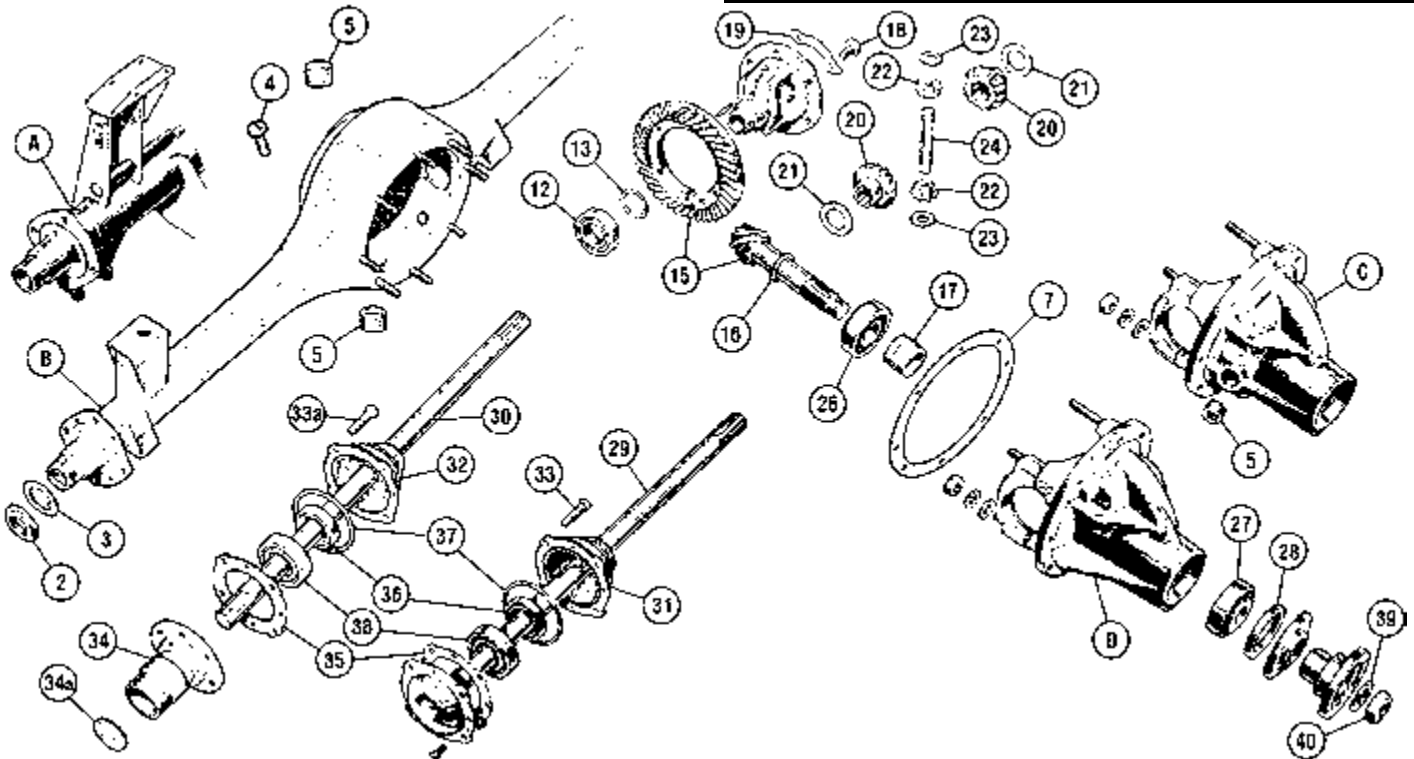

No.	Part No.	Price (each)	Description	Application	Qty. Req.
A		NA	AXLE HOUSING (1/4 elliptic springs)	Sprite Mkl, MkII Midget Mkl	1
B		NA	AXLE HOUSING (1/2 elliptic springs)	Sprite MkIII-on Midget MkII-1500	1
C		NA	CARRIER HOUSING 948	Sprite to (c)24731 Midget to (c)16183	1
D		NA	CARRIER HOUSING 1098 thru 1500	Sprite from (c)24732 Midget from (c)16184	1
2	311-620	\$8.89	NUT, R/H hub (RH threads)		1
	461-260	\$8.89	NUT, L/H hub (LH threads)		1
3	265-560	\$1.89	TAB WASHER		2
4	267-040	\$7.99	BREATHER		1
5	319-060	\$2.89	DRAIN/FILLER PLUGS		2
7	294-210	\$1.19	GASKET, differential		1
12	127-300	\$39.49	BEARING, differential		2
13	265-320	\$1.99	SHIM, bearing, .002"		A/R
	265-330	\$1.99	SHIM, bearing, .003"		A/R
	265-340	\$1.99	SHIM, bearing, .004"		A/R
	265-350	\$1.79	SHIM, bearing, .010"		A/R
15		NA	GEAR SET, 4.22:1	housing "C"	1
	265-360	NA	GEAR SET, 4.22:1 (9 x 38 teeth)		1
	265-370	\$599.99	GEAR SET, 3.90:1 (10 x 39 teeth)	housing "D"	1
	265-375	\$599.99	GEAR SET, 3.73:1 (11 x 41 teeth)	(will not fit housing "C")	1
	265-265	\$619.99	GEAR SET, 3.55:1		1
16		NA	THRUST WASHER, pinion, from 0.116" to 0.130"		A/R
17		NA	SPACER, solid	housing "C"	1
	265-750	\$13.29	SPACER, collapsible	housing "D"	1
18	320-640	\$1.89	BOLT		6
19	265-255	\$1.19	LOCKTAB		3
20	265-240	NA	DIFFERENTIAL GEAR		2
21	265-250	\$2.49	THRUST WASHER		2
22	265-260	NA	PINION, differential		2
23	265-270	\$6.89	THRUST WASHER, differential pinion		2
24	265-280	\$29.99	PINION AXLE		1
25	265-290	NA	LOCKING PIN, pinion axle		1
26	125-130	\$219.99	BEARING, rear inner pinion	housing "C"	1
	125-150	\$29.59	BEARING, rear inner pinion	housing "D"	1
27	125-805	\$38.99	BEARING, front outer pinion	housing "C"	1
	125-140	\$17.49	BEARING, front outer pinion	housing "D"	1
28	120-800	\$2.19	OIL SEAL	all	1
29	265-300	\$274.99	AXLE SHAFT, disc wheels		2
	265-302	\$359.99	AXLE SHAFT, disc wheels, nitride toughened		2
30	265-310	\$199.99	AXLE SHAFT, wire wheels		2
	265-312	\$239.99	AXLE SHAFT, wire wheels, nitride toughened		2

No.	Part No.	Price (each)	Description	Application	Qty. Req.
31	265-210	NA	BEARING HUB, disc wheels		2
32	265-215	NA	BEARING HUB, wire wheels		2
33	265-540	\$3.89	STUD, disc wheels		8
33a	265-550	\$8.49	STUD, wire wheels		8
34	265-220	\$118.99	EXTENSION, R/H, wire wheels, 12 tpi	Sprite MkII	1
	265-225	\$118.99	EXTENSION, L/H, wire wheels, 12 tpi	Midget Mkl	1
	265-230	\$119.99	EXTENSION, R/H, wire wheels, 8 tpi	from Sprite MkIII	1
	265-235	\$119.99	EXTENSION, L/H, wire wheels, 8 tpi	Midget MkII-1500	1
34a	328-260	\$0.59	PLUG, extension	wire wheels	2
	125-830	\$17.49	HUB BEARING KIT, incl. #3, 35, 36, 37, 38		2
35	296-030	\$0.69	GASKET, hub		2
36	120-030	\$2.39	OIL SEAL		2
37	121-410	\$1.39	O-RING		2
38	125-120	\$14.89	BEARING, hub		2
39	324-100	\$0.49	LOCKWASHER		1
40	310-570	\$2.89	NUT		1

## Speedi-Sleeve



Differential pinion seal. (use on differential flange)  
When a new seal cannot compensate for excessive damage, this ultra-thin sleeve provides a "new" sealable surface. Instructions and installation tool are included.  
**520-500 \$54.99**

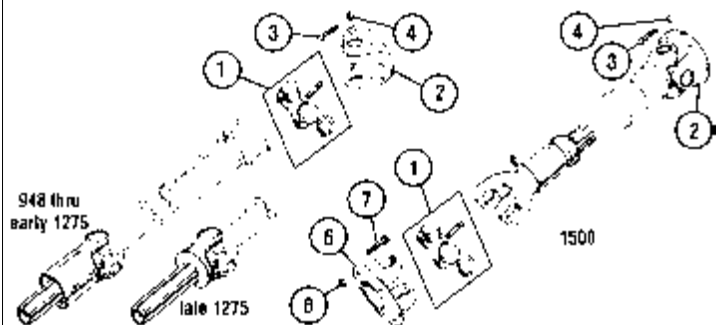

No.	Part No.	Price (each)	Description	Application	Qty. Req.	
1	268-060	\$19.99	U-JOINT, GKN/Hardy-Spicer	}	2	
	268-061	\$9.49	U-JOINT, aftermarket		2	
2	268-010	\$25.29	FLANGE to differential	} all	1	
3	322-310	\$0.79	BOLT to differential flange		4	
4	310-290	\$0.69	NUT, nyloc		4	
6	674-925	\$29.99	FLANGE to gearbox		1	
7	320-395	\$1.59	BOLT to gearbox flange		} 1500	4
8	310-240	\$0.39	NUT, nyloc			4

**LOCAL & OVERSEAS: 805-681-3400**  
**FAX: 805-692-2525** [www.mossmotors.com](http://www.mossmotors.com)



# Steering Wheels

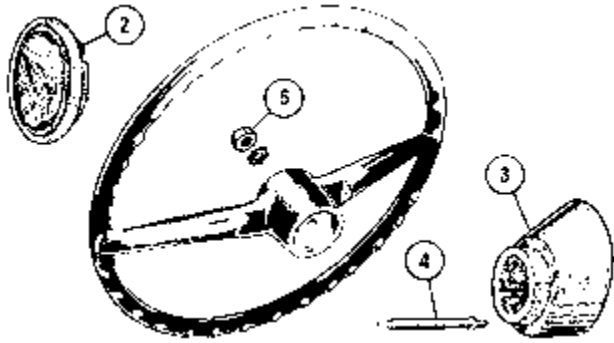

2	408-125	\$49.99	HORN PUSH, Sprite	1
	408-135	\$46.99	HORN PUSH, Midget (with MG logo)	1
	667-425	\$0.39	CLIP, horn push	2
3	233-215	\$159.99	SURROUND, LHD (includes slip ring)	1
	233-216	\$159.99	SURROUND, RHD (includes slip ring)	1
4	560-430	\$6.49	HORN BRUSH	1
	667-590	\$19.99	SLIP RING*	1
5	263-075	\$5.19	NUT, steering wheel	1

} Sprite Mkl, MklII  
Midget Mkl

\*Slip ring has a plastic base - remove it for this application.

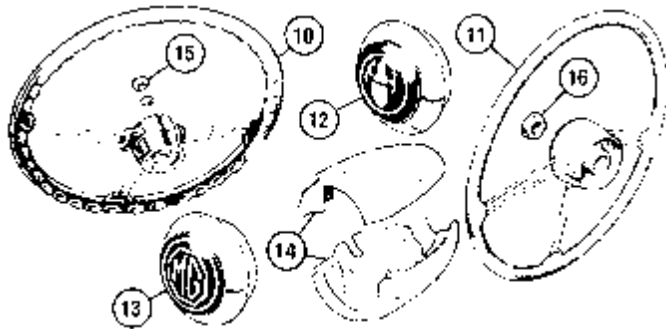

10	453-865	NA	STEERING WHEEL	1964-'67	1
11	453-960	NA	STEERING WHEEL (collapsible column)	1968-'69	1
12	408-155	NA	HORN PUSH	Sprite 1964-'67	1
13	408-145	NA	HORN PUSH	Midget 1964-'67	1
	667-425	\$0.39	CLIP, horn push		3
14	233-205	\$42.99	COWL, steering column	1964-'67	1
15	263-080	\$9.89	NUT (solid column)	1964-'67	1
16	263-085	\$13.99	NUT (collapsible column)	1968-'69	1

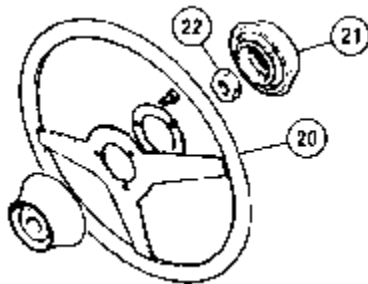

20	263-720*	NA	STEERING WHEEL*	Midget from GAN5-135882	1
21	408-275	\$66.99	CENTERPIECE, steering wheel	fits Midget from 1970-on	1
22	263-085	\$13.99	NUT, steering wheel	Midget thru (c)74885	1
		NA	NUT, steering wheel	Midget from (c)74886-on	1

\* This wheel will fit all Midgets from 1970, but does not have cut-outs in the spokes.

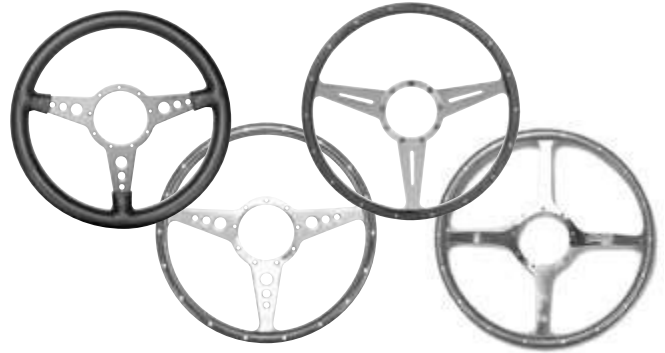

## Accessory Steering Wheels

Hand crafted steering wheels employ the finest bicolored wood laminations or smooth leather over aircraft quality aluminum frames. Personalize your car with these classic steering wheels. Simply choose the wheel you want and, then order the correct hub for your car.

### Wood Rim Steering Wheels

489-070	14" with 3 Drilled Matte Spokes	\$289.99
489-060	15" with 3 Drilled Matte Spokes	\$289.99
489-080	15" with 3 Slotted Matte Spokes	\$289.99
454-245	15" with 4 Solid Polished Spokes	\$499.99

### Leather Rim Steering Wheels

489-040	14" with 3 Drilled Black Spokes	\$229.99
489-030	14" with 3 Drilled Matte Spokes	\$229.99
489-020	15" with 3 Drilled Black Spokes	\$229.99
489-050	15" with 3 Slotted Black Spokes	\$229.99

### Adaptor Hubs with Emblems - Sprite

905-346	Sprite Mkl & II - with 46mm enamelled emblem	\$109.99
454-368	Sprite MkIII, IV thru '67 - with 46mm enamelled emblem	\$109.99
905-478	Sprite MkIV 1968-69 - with 46mm enamelled emblem	\$179.99

### Adaptor Hubs with Emblems - Midget

905-348	Midget Mkl - with 46mm enamelled emblem	\$109.99
454-366	Midget MkII, III thru '67 - with 46mm enamelled emblem	\$109.99
905-468	Midget MkIII, 1968-69 - with 46mm enamelled emblem	\$179.99
905-482	Midget 1970-'77 - with 46mm enamelled emblem	\$89.99
905-486	Midget 1978-79 - with 46mm enamelled emblem	\$99.99



## Classic Steering Wheel

A slightly thicker rim than our other classic wooden wheels for a more positive grip (approx. 28mm or 1.1" in diameter). It also features non-glare matte finish spokes and rich solid mahogany wood. This will fit any of our classic steering wheel adaptor hubs.

**489-090 \$289.99**

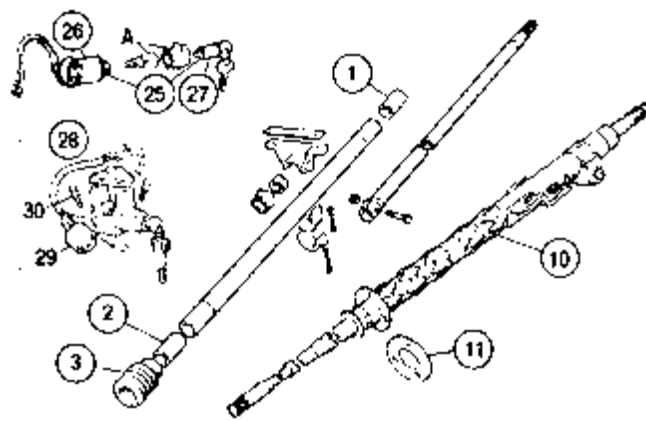
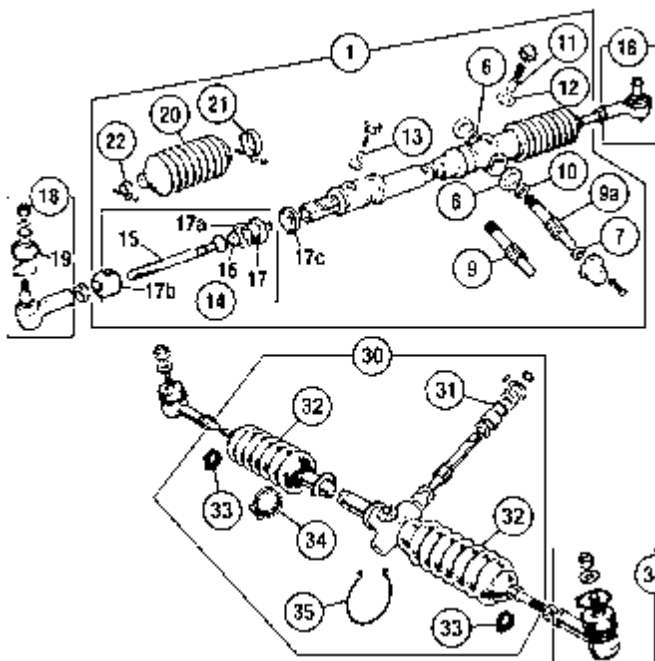

No.	Part No.	Price (each)	Description	Application	Qty. Req.
<b>Steering Racks</b>					
1	668-001	\$204.99	STEERING RACK ASS'Y. thru approx. 1967	} MG to (c)60440, AH to (c)72033	1
	668-002	\$204.99	STEERING RACK ASS'Y. approx. 1968 - mid '72		} MG from (c)60441 to 114486 AH from (c)72034 on
6	120-040	\$0.99	OIL SEAL, pinion thru approx. 1967	} MG to (c)60440, AH to (c)72033	1
	120-050	NA	OIL SEAL, pinion approx. 1968 - mid '72		} MG from (c)60441 to 114486 AH from (c)72034 on
7	260-220	NA	THRUST WASHER, pinion bottom	} all Sprite Midget to GAN5-114486 (to mid 1972)	1
8	260-230	NA	SHIM, lower pinion bearing, .003"		A/R
	260-240	NA	SHIM, lower pinion bearing, .005"		A/R
	260-250	NA	SHIM, lower pinion bearing, .010"		A/R
9	663-310	NA	STEERING PINION, w/flat on splines		1
9a	663-300	\$48.99	STEERING PINION, w/groove on splines		1
10	663-320	\$0.39	THRUST WASHER, pinion top		1
11	262-190	\$29.99	DAMPER PAD, pinion		1
12	262-120	\$4.99	SHIM, .003"		A/R
	260-270	NA	SHIM, .010"		A/R
13	263-040	\$9.99	DAMPER PAD, secondary		1
14	260-330	NA	TIE ROD ASSEMBLY, inner		2
15	260-280	NA	TIE ROD		2
16	260-290	\$8.69	SOCKET		2
17	262-170	\$13.49	BALL HOUSING, male		2
17a	262-130	\$3.29	SHIM, .003"		A/R
	262-140	\$3.29	SHIM, .005"		A/R
	262-150	\$3.29	SHIM, .010"		A/R
17b	262-160	\$22.49	BALL HOUSING, female		2
17c	262-110	\$9.89	LOCK WASHER		2
18	263-288	\$19.89	TIE ROD END, pair		1
19	262-220	\$1.89	BOOT, tie rod end		2
20	260-325	\$15.79	RACK BOOT SET, replacement, w/ties	1	
	260-320	\$10.99	RACK BOOT, orig. type	2	
21	263-230	\$2.29	CLAMP, large	2	
22	262-200	\$1.89	CLAMP, small	2	
30	668-000	\$219.99	STEERING RACK ASSEMBLY, LHD	} MG 1275 from (c)114487 & 1500 (mid '72-on)	1
31	668-010	NA	SHIM, .005"		A/R
	668-020	\$0.89	SHIM, .010"		A/R
32	680-058	\$12.69	RACK BOOT SET, 2 boots (incl. zip ties to replace clamps)		1
33	326-475	\$1.69	CLAMP, small		2
34	326-410	\$2.39	CLAMP, large (passenger's side)		1
35	674-870	\$0.29	WIRE TIE (driver's side)	1	
36	668-040	\$16.89	TIE ROD END PAIR	1	

No.	Part No.	Price (each)	Description	Application	Qty. Req.
<b>Steering Columns</b>					
1	667-600	\$4.49	BUSH, upper, felt	} non-collapsible steering columns	1
2	263-420	\$2.89	BUSH, lower, felt		1
3	280-880	\$4.49	SEAL, steering col. to toe board		Bugeye to (c)7432 from (c)7433 thru 1967
10		NA	STEERING COLUMN, collapsible (several variations)	} from approx. 1968-on	1
11	263-590	\$1.89	SEAL		1
25	263-600*	NA	IGNITION SWITCH ASS'Y.	} MG from (c)60441-74885 AH from HAN9-72034 on	1
26	542-077*	\$9.99	IGNITION SWITCH		1
27	163-500*	\$5.89	LOCK BARREL w/2 keys		1
28	263-610	\$44.99	LOCK & SWITCH ASS'Y (replacement)	} MG from (c)74886 to 1154100	1
29	263-655	NA	SWITCH (for orig. ass'ys. only)		1
	263-641	\$94.49	LOCK & SWITCH ASS'Y, Lucas	} Midget 1500, 1975 on	1
	263-640	\$44.99	LOCK & SWITCH ASS'Y, aftermarket		1
	263-691	\$26.49	SWITCH, Lucas		1
	263-690	\$19.79	SWITCH, aftermarket		1
	163-337	\$4.99	KEY BLANK		A/R
30	263-700	\$3.39	SHEAR BOLT (incl. with assemblies)		2

\*U.S.-spec column mounted ignition switches are locking-type. Ignition switch #542-077 is similar to the original, but has Lucar spade terminals in place of the wires found on the original switches. To use this replacement switch, three wires approximately 14" long must be attached to the switch with female Lucar connectors (#161-520). To connect the other ends of these wires to your harness, use wire tips, #162-200, and connectors, #162-000. Parts marked "A" in the illustration are no longer available and must be re-used from your old switch assembly.

The most common causes of steering shake are wheel imbalance, tire belt separation, bad shock absorbers and worn wheel bearings. Harder to find problems arise from loose steering rack mounts and out-of-round brake rotors. The most elusive shake is caused by wear in the steering rack itself. This is an unfamiliar problem just coming into its own, due to the age of the affected cars.

The problem manifests itself in localized intermittent shaking in the steering wheel, and is difficult to sort out as most suspension problems end up being felt through the steering wheel. A clue is afforded by determining which parts of the car are shaking as well as the steering wheel. If the cowl or fenders are shaking, the problem lies with suspension parts, not the rack.

There is much you can do to eliminate shake and shimmy not connected with the rack. See that everything is mounted properly and securely as your safety depends on your steering system being in first class operating condition.

# Front Suspension

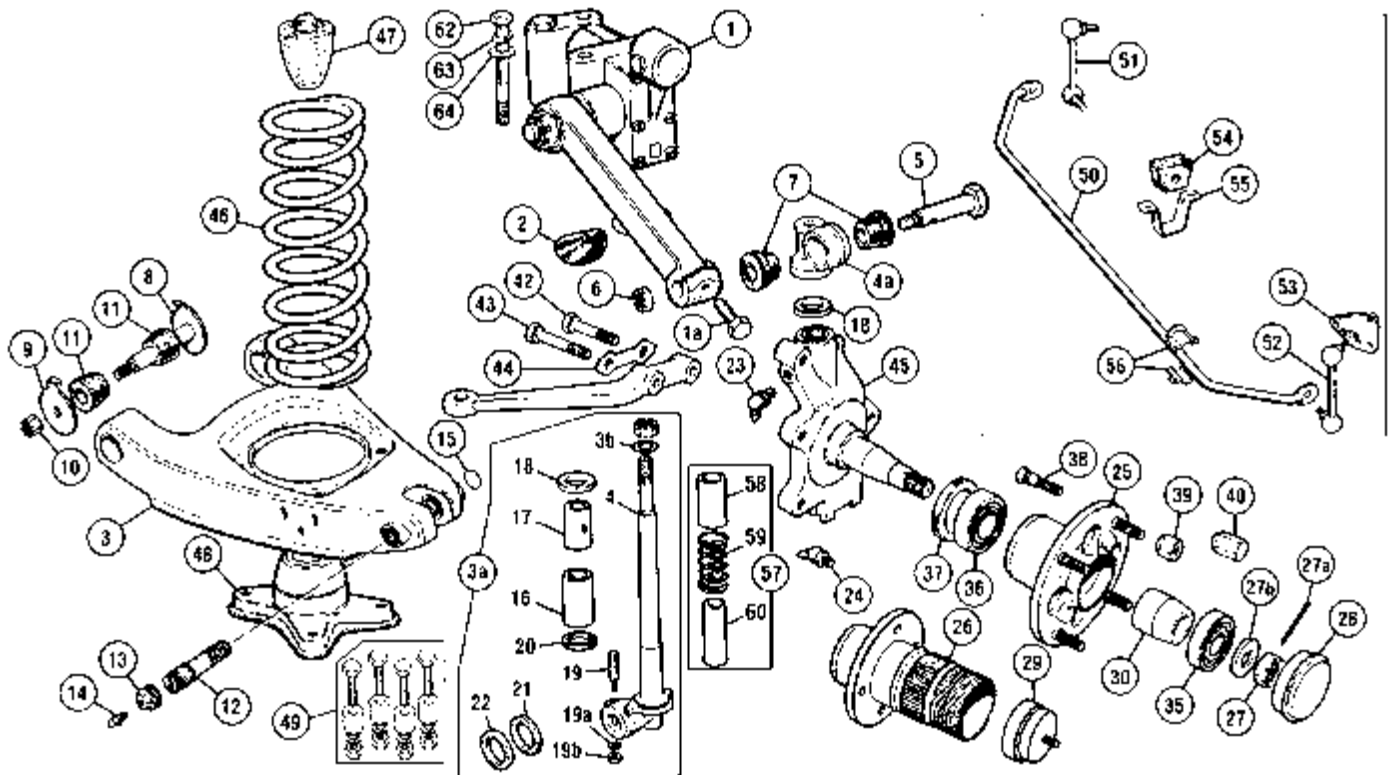

No.	Part No.	Price (each)	Description	Application	Qty. Req.
1	264-000	\$214.99	SHOCK ABSORBER, R/H, new		1
	264-005	\$214.99	SHOCK ABSORBER, L/H, new		1
	264-015	\$132.99	SHOCK ABSORBER, R/H, rebuilt		1
		\$175.00	CORE CHARGE FOR 264-015 SHOCK ABSORBER		
	264-025	\$132.99	SHOCK ABSORBER, L/H, rebuilt		1
		\$175.00	CORE CHARGE FOR 264-025 SHOCK ABSORBER		
1a	322-410	\$1.19	CLAMP BOLT		2
2	264-055	\$1.99	BUFFER, rebound		2
3	264-065	\$319.99	WISHBONE/SPRING PAN (British Motor Heritage part)		2
	264-067	\$99.99	WISHBONE/SPRING PAN, aftermarket, w/ pin no. 12		2
	264-078*	\$229.99	MAJOR SUSPENSION KIT (includes items marked*)	} 948 only drum brakes	1
3a	264-185*	\$129.99	SWIVEL PIN REPAIR KIT		1
	264-195*	\$53.99	FULCRUM PIN REPAIR KIT §		2
	264-088†	\$142.99	MAJOR SUSPENSION KIT (included items marked†)	} 1098, 1275, 1500 disc brakes	1
3a	264-205†	\$74.99	SWIVEL PIN REPAIR KIT		1
	264-195†	\$53.99	FULCRUM PIN REPAIR KIT §		2
§ Fulcrum pin repair kits include #5-14, 19-19b, 21-24.					
3b	264-086*†	\$0.99	SHIM, .008"	A/R	2
4	*	NA	SWIVEL PIN	948	2
	†	NA	SWIVEL PIN	1098, 1275, 1500	2
4a	264-405	\$31.89	TRUNNION		2
5	264-045*†	\$4.19	PIN, upper fulcrum		2
6	311-640*†	\$1.79	NUT		2
	325-330*†	\$0.19	COTTER PIN for nut		2
7	330-520*†	\$2.49	BUSH, top		4
8	264-145*†	\$5.59	BOLT with washer, inner fulcrum		4
9	324-395*†	\$2.59	WASHER, inner fulcrum		4
10	310-240*†	\$0.39	NUT, inner fulcrum bolt		4
11	282-305*†	\$1.49	BUSH, wishbone		8
12	264-075*†	\$14.79	FULCRUM PIN		2
13	328-455*†	\$4.89	PLUG		2
14	328-610*†	\$0.39	GREASE NIPPLE		2
15	328-014*†	\$1.69	PLUG, blanking		2
16	021-184*	\$11.99	BUSH, lower†	948	2
	330-400†	\$5.19	BUSH, lower†	1098, 1275, 1500	2
17	*	NA	BUSH, upper†	948	2
	330-540†	\$7.99	BUSH, upper†	1098, 1275, 1500	2
18	*†	NA	THRUST WASHER		2

No.	Part No.	Price (each)	Description	Application	Qty. Req.
19	264-445*†	\$2.29	PIN		2
19a	324-010*†	\$0.19	LOCKWASHER		2
19b	310-040*†	\$0.19	NUT		2
20	*†	NA	SEAL		2
21	264-425*†	\$1.39	SEAL, small cork		2
22	264-435*†	\$1.19	SEAL, large cork		2
23	328-505*†	\$0.89	GREASE NIPPLE, top		2
24	328-500*†	\$0.89	GREASE NIPPLE, bottom		2
25		NA	HUB, disc wheel	drum brakes	2
	264-245	\$109.99	HUB, disc wheel	disc brakes	2
26	264-225	\$131.99	HUB, R/H, wire wheels, 12 tpi	} Sprite MkII Midget MkI	1
	264-235	\$131.99	HUB, L/H, wire wheels, 12 tpi		1
	264-255	\$129.99	HUB, R/H, wire wheels, 8 tpi	} from Sprite MkIII, Midget MkII	1
	264-265	\$129.99	HUB, L/H, wire wheels, 8 tpi		1
27	310-085	\$4.99	NUT		2
27a	325-440	\$0.19	COTTER PIN		2
27b	264-952	\$2.39	WASHER		2
28	264-515	\$7.79	GREASE CAP, disc		2
29	662-030	\$5.69	GREASE CAP, wire		2
30	264-625	\$11.99	BEARING SPACER		2
	125-825*	\$119.99	WHEEL BEARING KIT  MORE INFO ONLINE		2
These are "face adjusted" to the correct width (thickness) Kit includes 2 bearings and 1 oil seal.					
35	126-010*	NA	BEARING, outer		2
36	126-020*	NA	BEARING, inner		2
37	120-910	\$2.49	OIL SEAL		2
•See page 45 for important bearing information and alternative bearings.					
38	264-415	\$3.89	STUD, disc wheels	drum brakes	8
	264-095	\$3.19	STUD, disc wheels	disc brakes	8
39	264-215	\$1.19	LUG NUT, plain, disc wheels		8
40	264-155	\$2.79	NUT, chrome for Rostyle wheels		8
	264-156	\$8.99	NUT, stainless steel for Rostyle wheels		8
42	322-077	\$2.79	BOLT, rear		2
43	322-078	\$3.29	BOLT, front		2
44	115-009	\$2.79	LOCKTAB		2
45	264-275	NA	SWIVEL AXLE, R/H	} 1098, 1275, 1500 disc brakes	1
	264-285	NA	SWIVEL AXLE, L/H		1

Note: † These bushes must be reamed or honed to fit the swivel pin being installed in the swivel axle. Consult workshop manual for instructions and dimensions.

No.	Part No.	Price (each)	Description	Application	Qty. Req.
46	265-590	\$51.99	SPRING	to HAN8-58380, GAN3-46040	2
	265-610	\$37.99	SPRING	{ from HAN8-58381 on GAN3-46041 to GAN6-171477	2
	265-620	\$53.99	SPRING	GAN6-171478 on	2
<b>More spring options are listed in the color section at the front of this catalog.</b>					
47	264-295	\$5.39	SUSPENSION BUFFER		2
48	264-305	\$28.89	SPRING SEAT		2
49	264-665	\$21.99	LOWERING KIT lowers car approx. 1/2"		1
50	264-105	\$139.99	SWAY BAR (anti-roll bar), 9/16"		1
51	264-115	\$12.89	LINK, R/H		1
52	264-125	\$12.89	LINK, L/H		1
53	264-135	\$6.19	BRACKET		2
54	280-920	\$1.39	RUBBER MOUNT for 9/16" sway bar		2
55	263-430	\$0.89	STRAP		2
56	263-778	\$4.89	LOCATOR PAIR with hardware		2
57	264-638	\$26.69	DUST TUBE KIT	drum brakes	2
58	264-315	\$6.99	DUST TUBE, upper	} all	2
59	264-655	\$0.39	SPRING, dust tubes		2
60	264-635	NA	DUST TUBE, lower	drum brakes	2
	264-645	\$10.99	DUST TUBE, lower	disc brakes	2
62	322-076	\$1.69	BOLT, shock mounting		6
63	324-040	\$0.29	LOCKWASHER		6
64	324-860	\$0.19	WASHER, flat		6



### "Suplex" Lowered Coil Springs

For chrome bumpered cars, these springs slightly lower the ride height while providing a useful increase in spring rate to 340 lbs./in. Made in Germany from chrome-silicon steel for lighter weight and greater fatigue resistance.

**264-606 \$154.99 pair**

More spring options are listed in the color section at the front of this catalog



### Front suspension Lowering Kit

This kit contains special spacers which install between the wishbone/spring pan and the spring seat to lower your front suspension one half inch. Works with all springs. Kit includes spacers and bolts for both sides. **264-665 \$21.99**

### Nylatron Upper Trunnion Bushes

Nylatron bushings firmly locate your front suspension and eliminate unnecessary movement. Standard camber trunnion bushings are a direct replacement for your original bushings. The negative camber bushings are designed primarily for competition purposes and give improved steering and braking control. Sold individually, 4 required per car.

**Standard Camber Bushing 264-585 \$24.99**  
**Negative Camber Bushing 264-595 \$24.99**



### 3/4" Sway Bar

The 3/4" sway bar is an excellent compromise for both fast road, and competition use. Increased front sway bar diameter reduces body roll and understeer which in turn gives better handling control.

**3/4" Sway bar 264-555 \$189.99**  
 Bushing, rubber (2 req'd.) 280-915 \$2.19  
 Bushing Pair, polyurethane 683-062 \$19.99  
 Strap (2 req'd.) 263-430 \$0.89



### Solid Sway Bar Mounts

Machined aluminum mounts may be employed for road use, but were primarily designed for competition purposes. Some increase in road noise can be expected. Use with 3/4" bars. Sold as a pair. **263-435 \$79.99**

# Front Suspension

## Front Suspension Advice

The front suspension will give good service if kept clean and lubricated. Few cars receive this level of attention, and inspection is impossible without a thorough cleaning. Front end condition should be considered before purchasing a car.

There should be no play in the steering or hub assemblies. Inspect the tie rod ends, hubs and uprights. The front end must be raised. Allow the suspension to hang by placing jack stands on the frame engine or under the rocker panels. Have someone turn the steering wheel from lock to lock while you observe the tie rod ends, which must not have any free play.

Lower king pin bushes and fulcrum pin and wishbone attachments wear out. Grasp the wheel at top and bottom and rock back and forth. (Figure A) Observe any clearance at the king pin and fulcrum pin. If the wheel rocks but there is no "gap" at the fulcrum pin, the hub bearings must be inspected. (Figure B)

All cars eventually need a front end rebuild. The use of new parts is best, as the fulcrum pin often fuses to the wishbone. Few of these parts are reusable.

Severe wear on the lever link is a problem with the single arm shocks. Check by removing the upper link and wiggling the arm back and forth (Figure C). If fluid leaks from the shaft seals, replace the shocks and top bushes.

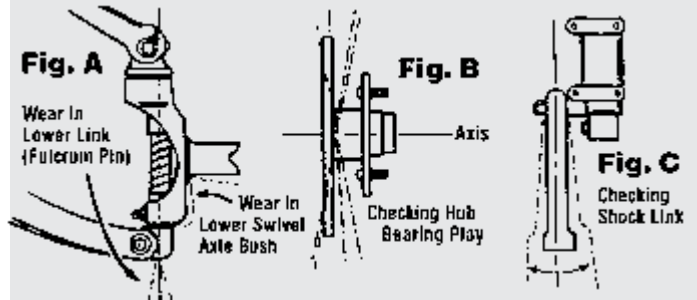

"Stiff steering" can be caused by hardened grease in the lower king pin bushes.

Temporary improvement can be made by removing the grease fittings and applying heat to melt out hardened grease. Work the steering from lock to lock while heating. When the joints seem "free", install new fittings and pump grease through the bush. Grease a second time after the joints are cold.

Replacement of the drive shaft is difficult and frustrating as you cannot reach nor see down the tunnel to guide the front flange. Support the front joint with a couple of pieces of cardboard or styrofoam placed across the coupling to hold the flange relatively straight. The spine is then easily mated to the transmission.

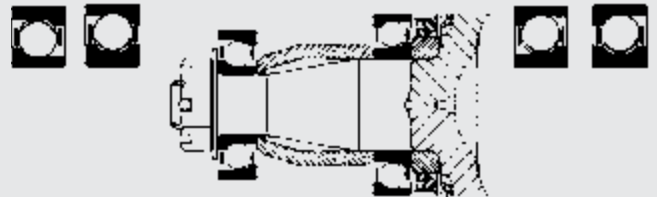

## Front Wheel Bearings

Front wheel bearings are thrust bearings; if installed backwards, the hubs may come loose from the axles. Bearings marked "thrust" on the outer race must have this marking face the bearing spacer. Bearings marked "thrust" on the inner races must be installed with the "thrust" marking away from the bearing spacer. Bearings with no "thrust" markings must be installed with the thicker edge of the outer races facing toward the bearing spacer. The illustration above shows the correct orientation of different available bearings. Note the orientation of the thrust (thick) and non-thrust (thin) sides of the bearing races.



## Tapered Roller Bearing Set

The standard front hub bearings are angular contact ball bearing type, which works well but does not allow for any adjustment as the bearings wear. Taper bearings provide better support. Our tapered bearing kit includes high quality bearings, seals, shims, split pin and nut and utilizes the standard spacer for a simple installation. The larger bearing has the correct 2mm fillet radius to allow proper fitment on the stub axle and has been specially manufactured to allow the hub to sit in the correct position so the caliper does not interfere with the disc. One kit does both sides.

**125-822 \$69.99**

## Shock Absorber Fluid

Don't risk damaging your shocks with the wrong type of hydraulic oil! This is the factory-recommended Armstrong fluid for all Triumph lever type shock absorbers. Available in 16 oz. plastic bottle. **220-304 \$17.99**



# Rear Suspension

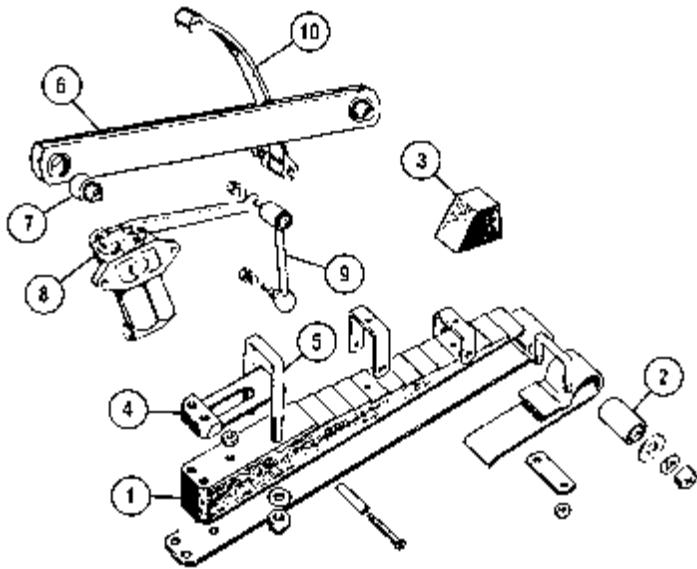

No.	Part No.	Price (each)	Description	Application	Qty. Req.
-----	----------	--------------	-------------	-------------	-----------

## 1/4 Elliptic System

1	265-460	NA	SPRING ASSEMBLY, standard	15 leaves	2
	265-630*	\$88.99	SPRING ASSEMBLY, heavy duty*	10 leaves	2
*Will raise ride height 2 to 3 inches. This is the only spring available.					
2	680-960	\$6.49	BUSH, silentbloc (supplied with spring)		2
3	282-220	\$5.89	BUMP RUBBER		2
4	265-600	\$8.89	SPRING PLATE		2
5	265-570	\$33.99	U-BOLT		2
	310-400	\$0.79	NUT, U-bolt		4
6	265-380	\$38.99	RADIUS ARM	} Sprite Mkl & MkII	2
7	265-390	\$9.79	BUSH	} Midget Mkl	4
8	265-400	\$189.99	SHOCK ABSORBER, new L/H		1
	265-410	\$189.99	SHOCK ABSORBER, new R/H		1
9	265-420	\$27.49	LINK, shock absorber		2
10	267-610	\$5.99	CHECK STRAP, stock type		2
	267-611	\$34.99	CHECK STRAP PAIR, nylon		1



## Safety Knock-Off Wrench

This cleverly designed long handle wrench allows you to tighten or remove octagon "safety" or "eared" spinners without a hammer. Stores easily in the trunk.

386-120	"Safety Knockoff" Wrench	\$53.99
386-125	"Eared Knockoff" Wrench	\$53.99
386-115	Fabric Wrench Cover	\$21.99

## Protective Knockoff Wrench

Prevent damage to knock-offs with this multi-ply wooden wrench.

386-165	\$29.89
---------	---------

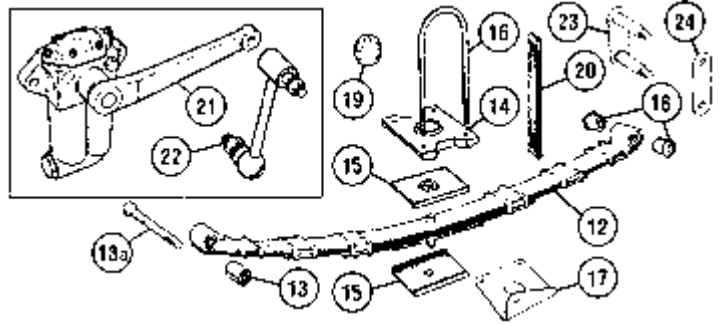

No.	Part No.	Price (each)	Description	Application	Qty. Req.
-----	----------	--------------	-------------	-------------	-----------

## 1/2 Elliptic System

12	265-490	\$124.99	SPRING	} MG MkII & MkIII } AH MkIII & MkIV	2	
	264-685	\$199.99	SPRING, lowered 1"		2	
	264-705	\$209.99	SPRING, lowered 2"		2	
	265-500	\$128.99	SPRING		Midget 1500	2
13	266-410	\$3.39	BUSH, silentbloc (supplied with springs)		2	
13a	280-903	\$3.89	BOLT, spring attachment		2	
14	265-396	\$4.79	PLATE, locating (upper & lower)		4	
15	280-900	\$1.39	PAD, seating		4	
16	265-395	\$2.39	U-BOLT		4	
	310-240	\$0.39	NUT, U-bolts		8	
17	265-392	\$20.99	BRACKET, R/H		1	
	265-393	\$20.99	BRACKET, L/H		1	
18	280-905	\$0.99	BUSH, shackle		8	
19	266-530	\$7.99	BUMP RUBBER		2	
20	267-610	\$5.99	CHECK STRAP, stock type	} 948 thru 1275	2	
	267-611	\$34.99	CHECK STRAP PAIR, nylon		Midget 1500	1
	267-615	\$5.99	CHECK STRAP, stock type			2
	267-616	\$34.99	CHECK STRAP PAIR, nylon		1	
21	265-430	\$178.69	SHOCK ABSORBER, new L/H	} Midget from MkII on } Sprite from MkIII on	1	
	265-440	\$178.69	SHOCK ABSORBER, new R/H		1	
	265-435	\$109.99	SHOCK ABSORBER, rebuilt L/H		1	
		\$175.00	CORE CHARGE FOR 265-435			1
	265-445	\$109.99	SHOCK ABSORBER, rebuilt R/H		1	
		\$175.00	CORE CHARGE FOR 265-445		1	
22	265-450	\$15.89	LINK, shock absorber		2	
23	265-455	\$7.69	SHACKLE PLATE, with pins		2	
24	265-465	\$5.49	SHACKLE PLATE		2	

## Lowered Rear Leaf Springs

Lowered springs are preferred to blocks and long U-bolts because they provide better location of the rear axle. Our 1" lowered springs are perfectly suited to fast road use. The 2" springs are appropriate for the track. Fit chrome-bumpered cars only from 1964-'74.

1964-'74	Rear Leaf Spring, 1" Lowered	264-685	\$199.99
1964-'74	Rear Leaf Spring, 2" Lowered	264-705	\$209.99

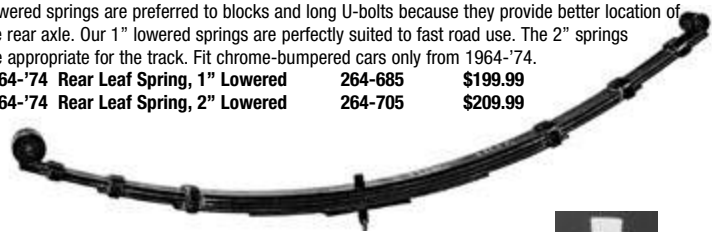

## Shock Absorber Fluid

Don't risk damaging your shocks with the wrong type of hydraulic oil! This is the factory-recommended Armstrong fluid for all Sprite & Midget lever type shock absorbers. Available in 16 oz. plastic bottle.

220-304	\$17.99
---------	---------



## Rear Tube Shock Conversion Kit

Fits 1964 to 1974 chrome bumper models. These kits contain the Spax adjustable gas filled shocks (adjustable from the outside), with new lower spring plates that incorporate an angled mounting flange. Installation is easy, and instructions are included.

264-675	\$499.99
---------	----------

**MOSS** MOSS MOTORS, LTD. TOLL-FREE ORDERS **1-800-667-7872**



### Bright Trim Ring Set

Deluxe, polished stainless steel trim rings. Our trim rings install in seconds and provide an attractive accent to your Rostyle disc wheels. Sold as a set of 4.  
**453-048 \$113.99**

### Inner Tubes and Rim Bands

Top quality heavy-duty tube designed for use with radial tires and have rubber covered valve stems. (Can be used with bias-ply tires.)  
**145/155/165 x 13" Inner Tube 452-736 \$19.99 ea.**



We offer high quality vulcanized rubber rim bands to prevent spoke and nipple ends from chafing your inner tubes.  
**13" Rim Band 452-730 \$9.69 ea.**



### Bolt-On Sport Wheels

Exact replica of the original Mini-lite wheel is an alternative to steel wheels. Give your British sports car a modern, aggressive look. Wheels bolt on using lug nuts listed below.  
**13" x 5" Wheel 453-065 \$159.99**  
 Lugnut, chrome 264-155 \$2.79 ea.  
 Lugnut, stainless 264-156 \$8.99 ea.  
 Lugnut, "MG" 264-465 \$3.79 ea.



### Silver Wheel Paint

The correct shade of silver-grey for your disc or wire wheels.  
**220-560 \$21.69**

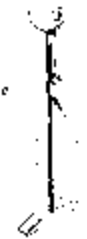

### 1500 Jack

Original style jack for use or to complete your show car. (May be used on earlier Sprites & Midgets.)  
**386-920 \$179.99**



### Early Type Jack Bag

Styled like the original factory-supplied jack bag made from heavy duty jute-backed vinyl. Complete with straps and buckles. Keeps the jack from banging around, a must for the restored car.  
**386-930 \$49.99**

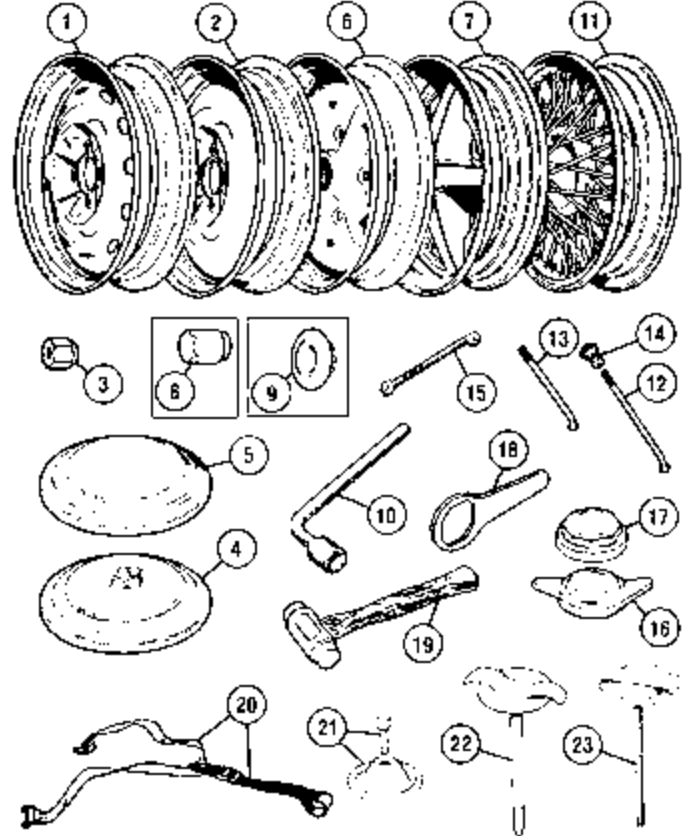

No.	Part No.	Price (each)	Description	Application	Qty. Req.
1		NA	WHEEL, steel, vented	948	5
2	455-450	NA	WHEEL, steel, non-vented	1098	5
3	264-215	\$1.19	LUG NUT, plain, disc wheels		16
4	200-340	\$68.99	HUBCAP, "AH"	} 948 & 1098	4
5	200-350	\$61.99	HUBCAP, plain, for Midget		4
6	455-455	NA	WHEEL, Rostyle	1275	5
7	455-460	NA	WHEEL, Rostyle	1500	5
8	264-155	\$2.79	NUT, chrome	} 1275 & 1500	16
	264-156	\$8.99	NUT, stainless steel		16
9	462-765	\$8.79	HUBCAP	} Rostyle wheels	4
	462-745	\$2.59	MG EMBLEM, hubcap		4
10	386-035	\$19.99	LUG WRENCH	disc wheels	1
11	454-675	\$259.99	WIRE WHEEL, painted	} 13 x 4", 60 spoke Quantities are per wheel	5
12	200-370	\$5.89	SPOKE, long, plain		20
13	200-380	\$5.89	SPOKE, short, plain		40
14	200-050	\$0.89	NIPPLE, plain		60
	454-685	\$355.99	WIRE WHEEL, chromed	} 13 x 4", 60 spoke Quantities are per wheel	5
	200-390	NA	SPOKE, long, chromed		20
	200-400	\$8.99	SPOKE, short, chromed		40
	200-052	\$1.89	NIPPLE, chromed		60
15	385-800	\$10.29	SPOKE WRENCH	wire wheels	1
16	200-290	\$47.99	KNOCK-OFF, R/H, eared	} Sprite MkII Midget MkI (12 t.p.i.)	2
	200-280	\$47.99	KNOCK-OFF, L/H, eared		2
	674-670	\$47.99	KNOCK-OFF, R/H, eared	} from Sprite MkIII Midget MkII (8 t.p.i.)	2
	674-680	\$47.99	KNOCK-OFF, L/H, eared		2
17	200-320	\$46.99	KNOCK-OFF, R/H, octagonal	} 12 t.p.i.	2
	200-310	\$46.99	KNOCK-OFF, L/H, octagonal		2
	310-315	NA	KNOCK-OFF, R/H, octagonal	} "MG" crested 12 t.p.i.	2
	310-305	NA	KNOCK-OFF, L/H, octagonal		2
	462-740	\$46.99	KNOCK-OFF, R/H, octagonal	} 8 t.p.i.	2
	462-730	\$46.99	KNOCK-OFF, L/H, octagonal		2
18	386-030	\$7.49	SPANNER, octagonal knock-offs		1
19	386-000	\$46.99	HAMMER, copper/copper faces, 1 lb.		1
	386-110	\$57.99	HAMMER, copper/rawhide faces, 2 lbs.		1
20	385-950	\$47.99	STRAP SET, spare tire	Bugeye	1
21	386-135	NA	CLAMP, spare wheel	std. steel wheels 1961-'67	1
22	386-145	NA	CLAMP, spare wheel	Rostyle wheels 1970-'80	1
23	386-155	NA	CLAMP, spare wheel	wire wheels 1961-'80	1

**LOCAL & OVERSEAS: 805-681-3400**

**FAX: 805-692-2525 www.mossmotors.com**



# Brake Hydraulics

Brake fluid and brake service tools are listed in the color section at the front of this catalog.

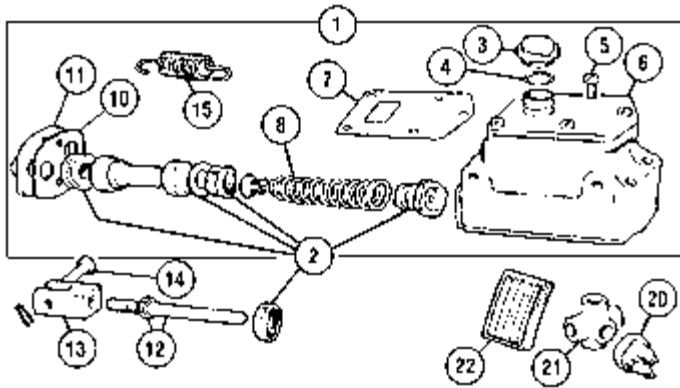

No.	Part No.	Price (each)	Description	Application	Qty. Req.
-----	----------	--------------	-------------	-------------	-----------

## Brake Hydraulics - 948 & 1098

1	180-672	\$239.99	MASTER CYLINDER, 7/8", AP Braking	948 drum brakes	1
	180-670	\$104.99	MASTER CYLINDER, 7/8", TRW		1
	180-673	\$69.99	MASTER CYLINDER, 7/8", Classic Gold		1
	180-555	\$163.99	MASTER CYLINDER, 3/4", TRW	1098 front disc brakes	1
2	180-971*	\$44.99	REPAIR KIT, 7/8", AP Braking	948	1
	180-970*	\$9.99	REPAIR KIT, 7/8", aftermarket		1
	180-565*	\$11.79	REPAIR KIT, 3/4", aftermarket		1098

\* These repair kits may include either a replacement type brake cylinder check valve, or the original type rubber cup for the original check valve.

3	180-210	\$4.49	CAP, plastic replacement	948 & 1098	1
	180-211	\$14.79	CAP, metal (as original)		1
4	180-451	\$2.99	WASHER, cap (metal cap)		9/7
5	323-500	\$0.99	SCREW, front & top covers		1
6	180-275	\$12.99	COVER		1
7	180-270	\$1.49	GASKET		1

8	180-030	\$4.79	SPRING	948	2
	181-710	NA	SPRING	1098	2

10	180-020	\$1.39	GASKET	948 & 1098	1
11	180-010	NA	PLATE		1
12	180-305	\$11.89	PUSH ROD, drum brakes, 4-1/8"		2
		NA	PUSH ROD, disc brakes, 3-11/16"		2
13	180-315	\$6.99	FORK		2
14	180-325	\$4.49	CLEVIS PIN		2
15	180-335	\$3.29	SPRING, pedal return	2	

20	141-700	\$7.99	SWITCH, brake light, screw conn.	Bugeye	1
	542-110	\$6.59	SWITCH, brake light, spade conn.	948, 1098	1
21	180-230	\$31.89	UNION, 4-way plus switch		1
	180-090	\$8.49	UNION, 3-way, rear		1
	322-247	\$0.49	BOLT, union to frame		1
	324-020	\$0.20	LOCKWASHER for bolt		1
22	280-930	\$1.49	PEDAL PAD, brake & clutch		2

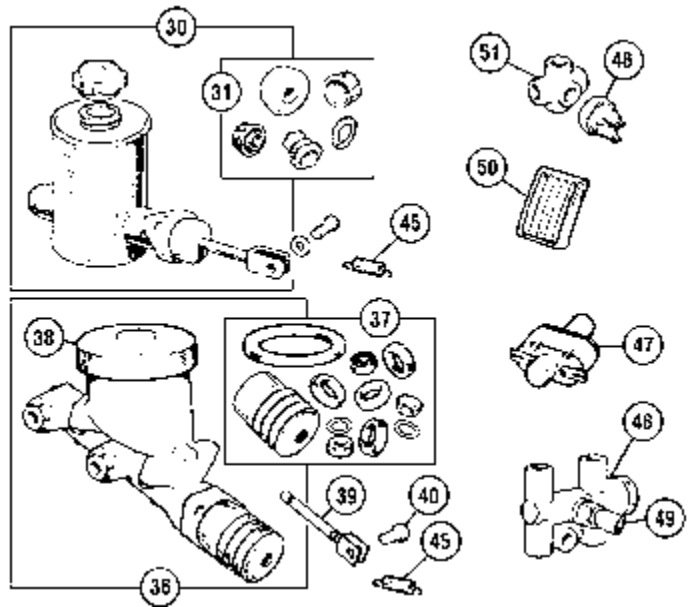

No.	Part No.	Price (each)	Description	Application	Qty. Req.
-----	----------	--------------	-------------	-------------	-----------

## Brake Hydraulics - 1275 & 1500

30	180-584	\$149.99	MASTER CYLINDER, Lockheed	(metal reservoir as orig.)	1
	180-585	NA	MASTER CYLINDER, AP Braking		(plastic reservoir)
	180-586	\$59.99	MASTER CYLINDER, aftermarket	some 1967 cars	1
31	180-875*	\$5.29	REPAIR KIT, cyls. not marked*		single line system
	180-985*	\$6.29	REPAIR KIT, marked cyls.*		1

\*See illustration below. Repair kits fit orig. cyls. only.

32	180-210	\$4.49	CAP, plastic (orig. cylinders only)		1
36	180-345	\$109.99	MASTER CYLINDER, TRW/Lucas	1275 & 1500 dual line system	1
	180-347	\$48.99	MASTER CYLINDER, aftermarket		1
37	180-205*	\$16.99	REPAIR KIT *		1

\*Repair Kit fits Lockheed, AP, TRW & Lucas master cylinders only. Disassembly of this master cylinder is very difficult without damage to some internal parts which are not available. We suggest no attempt be made to rebuild these.

38	180-215	\$15.99	CAP		1
39	181-695	NA	PUSH ROD		1
40	325-135	\$0.99	CLEVIS PIN		1

45	329-350	\$1.99	SPRING, pedal return	1275 & 1500	2
46	542-110	\$6.59	SWITCH, brake light, spade conn.	1275 (1967)	1
47	181-980	\$7.99	SWITCH, brake light	1275 from 1968, 1500	1
	310-070	\$0.39	JAM NUT for switch		1
48	141-710	NA	P.D.W.A. ASS'Y., brass	1275 & 1500 thru 1975	1
	141-720	NA	P.D.W.A. ASS'Y., cast iron	1500 from 1976-on	1
49	542-115	\$57.99	SWITCH for cast iron ass'y.		1
	141-725	\$54.99	SWITCH for brass ass'y.		1
	181-995	\$13.99	REPAIR KIT for original ass'y's. with "O"-ring seals		1
	181-985	\$34.99	REPAIR KIT for original ass'y's. with lip type seals (has new shuttle and replacement o-rings to replace orig. parts)		1
50	280-930	\$1.49	PEDAL PAD, brake & clutch		2
51	180-230	\$31.89	UNION, 4-way plus switch	1275 single line system	1
	180-090	\$8.49	UNION, 3-way, rear		1

Note: 1967 single line systems used either one of two master cylinders. The earlier has no identifying marking. The later has either of the markings shown below. The master cylinder assemblies are interchangeable, but the internal parts are not.

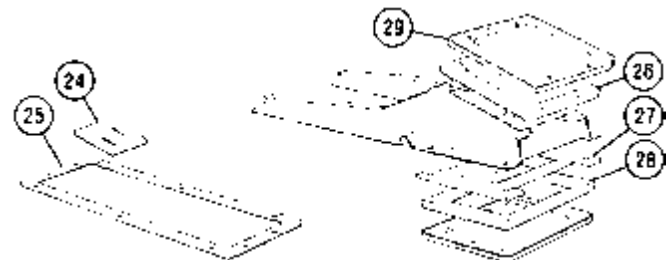
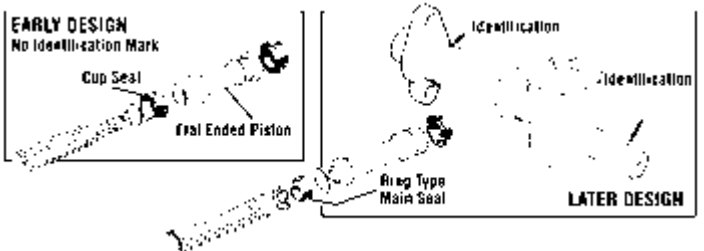

## Pedal Box Seals

24	280-085	\$1.39	EXCLUDER, fume & dust	948 & 1098	1
25	280-125	\$2.69	SEAL, pedal box to firewall		1
	280-125	\$2.69	SEAL, pass. side blanking plate		all
26	280-127	\$2.39	SEAL, top cover	1275 & 1500	1
27	280-126	\$2.69	SEAL, pedal box to firewall		1
28	280-128	\$3.39	SEAL, bottom blanking plate		1
29	280-129	\$22.89	TOP COVER		1





### Brake Pipe Sets

Moss brake pipe sets are made in England of high-strength corrosion resistant copper-nickel alloy tubing. Pipes are supplied coiled, but are much easier to bend smoothly and correctly than steel. All pipes come with end fittings and flares, and are individually coded to the instruction sheet so there is no doubt as to where they fit on your car. Note: These pipes have modern universal standard flares which are totally compatible with the original fittings.

184-008	\$139.99	BRAKE PIPE SET	Bugeye	1
184-018	\$149.99	BRAKE PIPE SET	Sprite MkII, Midget MkI (drum brakes)	1
184-028	\$139.99	BRAKE PIPE SET	1963-'67 (disc brakes)	1
184-038	\$149.99	BRAKE PIPE SET	1968-1974	1
184-048	\$149.99	BRAKE PIPE SET	Midget 1500	1

### Brake Pipe Bending Tool

Smooth bends on small diameter tubing such as brake lines are an important hallmark of quality craftsmanship. Give yourself an edge with our specially tubing bender which will give you smooth bends in 3/16, 1/4, 5/16, and 3/8 inch tubing. **385-905 \$20.99**



### Braided Stainless Steel/Teflon Brake Hose Sets

These competition-inspired brake hose sets meet all DOT safety standards and are street legal in all 50 states. Each set includes all brake hoses used on your car, with any required retaining nuts and/or copper sealing washers.

#### Goodridge brand (England)

Sprite-Midget (with front drum brakes)	182-198	\$78.99
Sprite-Midget (with front disc brakes)	182-248	\$78.99

#### Cobalt brand (USA)

Sprite-Midget (with front drum brakes)	180-358	\$74.99
Sprite-Midget (with front disc brakes)	180-378	\$74.99



### Brake Fluids

Choose the brake fluid your car needs. Genuine Lockheed Brake Fluid is compatible with all British brake systems. Silicone fluid won't harm paint, and doesn't absorb moisture, as do conventional fluids. (If changing from one type to the other, flush your brake system thoroughly with the "new" type of brake fluid.)

**Lockheed Brake Fluid 500 ml.**  
220-400 \$6.99

**Silicone Brake Fluid 1 liter**  
220-412 \$24.99

**Castrol Brake Fluid, 12 oz.**  
220-455 \$6.59

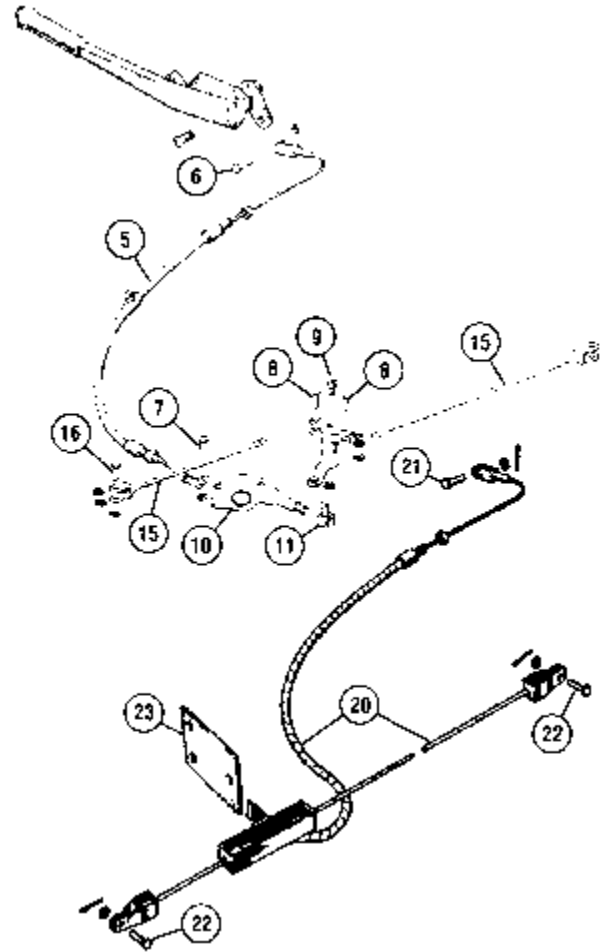

No.	Part No.	Price (each)	Description	Application	Qty. Req.
<b>Handbrake</b>					
5	331-660	\$20.59	HANDBRAKE CABLE	948 thru 1500 (c)182000	1
6	325-140	\$0.89	CLEVIS PIN, cable to handle		1
7	325-130	\$0.79	CLEVIS PIN, cable to lever		1
8	325-455	\$0.89	CLEVIS PIN, cross-rods to lever		2
9	328-500	\$0.89	GREASE NIPPLE		1
10	331-666	\$87.49	BRACKET, lever support		1
11	182-720	\$10.99	TRUNNION		1
15	NA		LINK ROD PAIR	Sprite thru HAN6-20792 Midget thru (c)13554	1
	331-668	\$44.99	LINK ROD PAIR (adjustable) (for disc or wire wheels)	Sprite from HAN6-20793 Midget (c)13555 thru 182000	1
16	325-135	\$0.99	CLEVIS PIN, outer ends of rods	(all except 1500)	2
20	331-670	\$19.79	HANDBRAKE CABLE ASSEMBLY disc wheels	1500 from (c)182001 on	1
	331-680	\$39.89	HANDBRAKE CABLE ASSEMBLY wire wheels		1
21	325-135	\$0.99	CLEVIS PIN, cable to handle		1
22	325-255	\$0.89	CLEVIS PIN, cable to wheel		2
23	182-345	\$1.89	STRAP, handbrake cable to axle		1



# Front Brakes

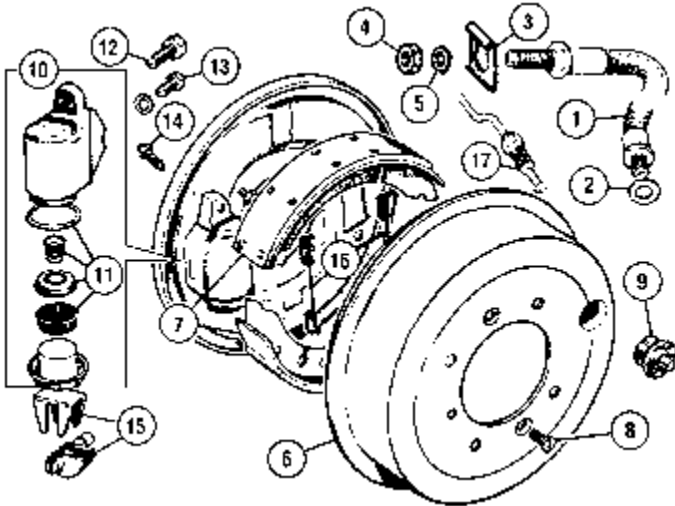

No.	Part No.	Price (each)	Description	Application	Qty. Req.
-----	----------	--------------	-------------	-------------	-----------

## 948 Front Brakes

1	180-355	\$26.99	HOSE, front, Delphi-Lockheed		2
	180-356	\$13.89	HOSE, front, aftermarket		2
2	324-730	\$0.39	WASHER, copper		2
3	181-660	\$2.39	LOCKING PLATE		2
4	310-070	\$0.39	JAM NUT		2
5	324-045	\$0.24	LOCKWASHER		2
6	181-885	\$29.99	BRAKE DRUM, front, premium repro.		2
	181-887	\$18.69	BRAKE DRUM, front, Classic Gold		2
7	182-120	\$17.49	BRAKE SHOE SET, front		1
8	323-250	\$0.39	SCREW, front drum to hub		4
9	181-975	\$1.19	PLUG, front & rear drums		4
10	180-640†	\$26.99	WHEEL CYLINDER, R/H front, Delphi-Lockheed		2
	180-641†	\$15.69	WHEEL CYLINDER, R/H front, aftermarket		2
	180-650†	\$26.99	WHEEL CYLINDER, L/H front, Delphi-Lockheed		2
	180-656†	\$15.69	WHEEL CYLINDER, L/H front, aftermarket		2
† All current cylinders use lip type seals. Rebuild kits are not available for these.					
11	180-458	\$56.99	REBUILD KIT, 4 cylinders (orig. cyls. w/cup seals)		1
	180-459	\$14.99	REBUILD KIT, 1 cylinder (orig. cyls. w/cup seals)		4
	180-180	\$1.19	SPRING		4
	180-170	\$2.79	EXPANDER		4
	180-940	\$12.99	CUP & RING		4
12	322-880	\$0.49	BOLT, large		4
13	322-400	\$3.19	BOLT, small		4
14	180-100	\$1.39	BLEEDER, front & rear		4
15	180-105	NA	ADJUSTER & MASK		6
16	182-680	\$4.89	SPRING, shoe return, front		4
17	181-125	NA	PIPE, between ft. wheel cylinders		2

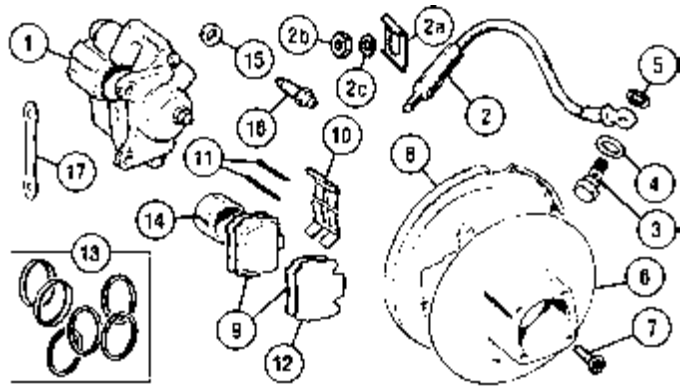

No.	Part No.	Price (each)	Description	Application	Qty. Req.
-----	----------	--------------	-------------	-------------	-----------

## Front Disc Brakes

1	182-718	\$139.99	CALIPER PAIR, new		1
	182-703	\$73.99	CALIPER ASS'Y., new, R/H		1
	182-713	\$73.99	CALIPER ASS'Y., new, L/H		1
2	180-375	NA	HOSE, front disc brake, OE		2
	180-376	\$9.69	HOSE, front disc brake, aftermarket		2
2a	181-660	\$2.39	LOCKING PLATE		2
2b	310-070	\$0.39	JAM NUT		2
2c	324-045	\$0.24	LOCKWASHER		2
3	180-430	\$5.99	BANJO BOLT		2
4	324-720	\$0.79	WASHER, copper, large		2
5	324-730	\$0.39	WASHER, copper, small		2
6	182-155	\$66.99	BRAKE ROTOR, "Brembo" brand	} disc wheels	2
	182-156	\$17.49	BRAKE ROTOR, aftermarket		2
	182-145	NA	BRAKE ROTOR, "Brembo" brand	} wire wheels	2
	182-146	\$15.99	BRAKE ROTOR, aftermarket		2
	586-600	\$199.99	BRAKE ROTOR PAIR, cross-drilled/slotted	disc wheels	1
7	322-435	\$2.69	BOLT, brake rotor		8
8	182-265	\$23.99	DUST COVER, R/H		1
	182-275	\$23.99	DUST COVER, L/H		1
9	071-539	\$21.69	PAD SET, Classic Gold, semi-metallic	} see color section at front of this catalog for details	1
	071-533	\$35.99	PAD SET, Classic Gold, ceramic		1
	585-605	\$109.99	PAD SET, "Hawk"		1
	585-625	\$76.99	PAD SET, "Greenstuff"		1
10	181-965	\$1.89	RETAINER		2
11	325-430	\$0.39	COTTER PIN		4
12	181-935	\$1.69	SHIM, anti-squeal		4
	182-890	\$28.99	PISTON & SEAL KIT, for 2 calipers		1
13	182-840	\$9.99	REPAIR KIT, for two calipers		1
14	182-810	\$9.99	CALIPER PISTON, stock type		4
	181-926	\$17.99	CALIPER PISTON, stainless steel		4
15	180-285*	\$0.79	SEAL, fluid channel, between caliper halves		2
16	180-100	\$1.39	BLEEDER SCREW		2
17	181-670	\$0.59	TAB WASHER		2

\*This seal is included in the repair kit, but caliper halves should never be separated. If, for some reason, you have ignored warnings not to do this, this seal is available.



## Disc Brake Kits

When your Sprite or Midget needs a brake job, ordering one part number and getting everything you need at once makes the job so much easier.

### Stock type

Disc wheels	182-157	\$51.99
Wire wheels	182-161	\$54.99

### Stage 1 (slotted/drilled rotors, ceramic pads)

Disc wheels	182-690	\$159.99
Wire wheels	182-695	\$159.99



## Cross-Drilled & Slotted Brake Rotors

Stop! Cross drilled rotors cool better for reduced brake fade and scrub off water faster in the wet. Special rotational hole pattern. For disc wheel cars. Sold as pairs only.

586-600 \$199.99

MOSS

MOSS MOTORS, LTD.  
TOLL-FREE ORDERS

1-800-667-7872

# Rear Brakes

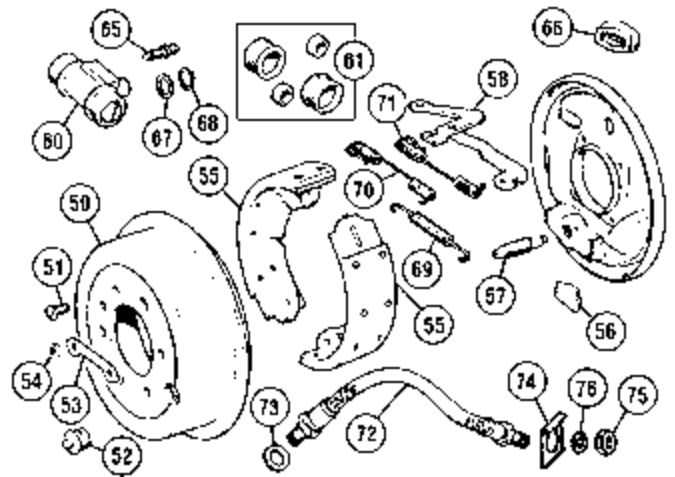
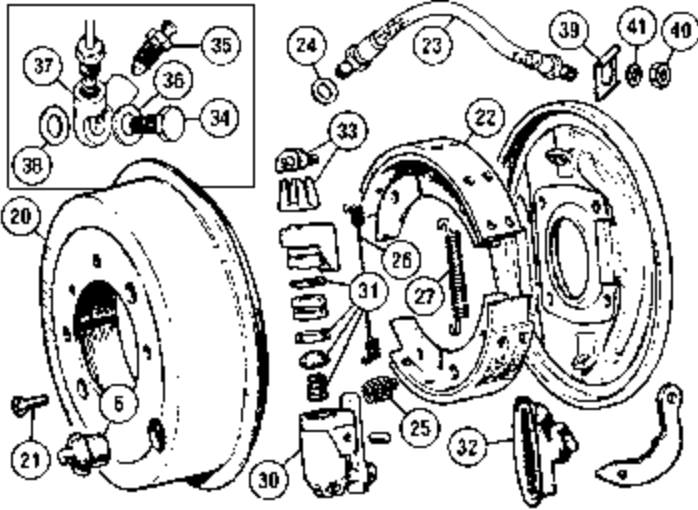

No.	Part No.	Price (each)	Description	Application	Qty. Req.
-----	----------	--------------	-------------	-------------	-----------

### Early 948 Rear Brakes

to G-AN1-13554 and H-AN6-20544 (approx.).

20	181-885	\$29.99	BRAKE DRUM, rear, premium repro.	Sprite to HAN6-20544 Midget to GAN1-13554 for orig. cyls. only	2
	181-887	\$18.69	BRAKE DRUM, front, Classic Gold		2
21	323-255	\$0.69	SCREW, rear drum to hub		4
22	182-140	\$15.99	BRAKE SHOE SET, rear		1
23	180-895	\$20.99	HOSE, rear		1
	180-896	\$12.99	HOSE, rear, aftermarket		1
24	324-730	\$0.39	WASHER, rear		1
25	181-340	\$1.49	SPRING, shoe steadying		4
26	182-655	\$5.49	SPRING, cylinder end		2
27	182-660	\$4.99	SPRING, abutment end		2
30	181-285*	\$22.99	WHEEL CYLINDER*, rear, w/lever		2
31	180-470	\$24.99	REPAIR KIT, for 2 cylinders		1
32	180-950	\$9.79	BOOT (not incl. w/cylinders)		2
33	180-105	NA	ADJUSTER & MASK		6
34	180-130	\$7.89	BANJO BOLT		2
35	180-100	\$1.39	BLEEDER, front & rear		4
36	324-720	\$0.79	WASHER, large copper		2
37	180-460	NA	BANJO FITTING		2
38	324-730	\$0.39	WASHER, small copper		2
39	181-660	\$2.39	LOCKING PLATE		1
40	310-070	\$0.39	JAM NUT		1
41	324-045	\$0.24	LOCKWASHER		1

\* Wheel Cylinder 181-285 is Classic Gold brand, and uses a modern lipped ring type seal instead of the original cup seal. Rebuild kits are not available for these wheel cylinders.

No.	Part No.	Price (each)	Description	Application	Qty. Req.
-----	----------	--------------	-------------	-------------	-----------

### Late 948 thru 1500 Rear Brakes

from G-AN1-13555 and H-AN6-20545 (approx.).

50	181-885	\$29.99	BRAKE DRUM, rear, premium repro.	wire wheels	2
	181-887	\$18.69	BRAKE DRUM, front, Classic Gold		2
51	323-255	\$0.69	SCREW, drum to hub		4
52	181-975	\$1.19	PLUG		2
53	181-915	\$0.89	TAB WASHER		4
54	310-075	\$0.39	NUT		8
	115-139	NA	BRAKE SHOE SET, Mintex		1
	182-175	\$15.99	BRAKE SHOE SET, Classic Gold		1
	181-906	\$9.99	ADJUSTER KIT (for one side)		2
56	181-895	NA	ADJUSTER TAPPET		4
57	181-905	NA	ADJUSTER WEDGE		2
	182-676	\$9.99	LEVER ASS'Y., R/H	1	
	182-677	\$9.99	LEVER ASS'Y., L/H	1	
60	180-445	NA	WHEEL CYLINDER, Lockheed	7/8" bore	2
	180-446	\$19.89	WHL. CYLINDER, aftermarket *		2
61	180-480	\$4.29	REPAIR KIT, aftermarket **	Sprite (c)20545 to 24731 Midget (c)13555 to 16183	2
	180-385	\$29.99	WHEEL CYLINDER, 3/4", Lockheed		2
	180-386	\$11.99	WHEEL CYLINDER, 3/4", aftermarket *	1098 & 1275	2
	180-406	\$8.99	REPAIR KIT, AP Braking brand **		2
	180-405	\$5.99	REPAIR KIT, aftermarket **		2
	180-395	\$31.99	WHEEL CYLINDER, rear, Lockheed	1500	2
	180-396	\$11.49	WHEEL CYLINDER, rear, aftermarket *		2
	071-526	\$5.29	REPAIR KIT, aftermarket **		2
65	323-145	\$1.49	BLEED NIPPLE (incl. with wheel cylinders)	all original fitment replaces #67 & 68	2
66	181-760	\$1.39	BOOT		2
67	180-575	\$5.99	WASHER, cylinder retaining		2
68	326-945	\$1.19	CIRCLIP		2
	326-720	\$1.39	"C" CLIP, cylinder retaining		2
69	182-665	\$4.29	SPRING, abutment end		2
70	182-670	\$4.99	SPRING, R/H, cylinder end		1
71	182-675	\$4.99	SPRING, L/H, cylinder end		1
72	180-895	\$20.99	HOSE, rear brake		1
	180-896	\$12.99	HOSE, rear brake, aftermarket		1
73	324-730	\$0.39	WASHER, copper		1
74	181-660	\$2.39	LOCKING PLATE	1	
75	310-070	\$0.39	JAM NUT	1	
76	324-045	\$0.24	LOCKWASHER	1	

\* No rebuild kits are available for these aftermarket wheel cylinders.

\*\* Rebuild kits fit only original wheel cylinders.



### Brake Adjuster Wrench

Get a better grip on your brake adjusters with our specially designed wrench. It has 1/4" and 5/16" square box ends, and a long handle for good leverage.

386-160 \$9.89

LOCAL & OVERSEAS: 805-681-3400  
 FAX: 805-692-2525 www.mossmotors.com



# Body Panels, Bugeye

Most of our body panels are shipped from overseas, and consequently invariably have some scratches and often minor dents. Panels will likely require alterations to fit your particular car accurately. Please anticipate some clean-up and/or modifications. Test fit body panels before modifying or painting - once altered or painted, they are not returnable.

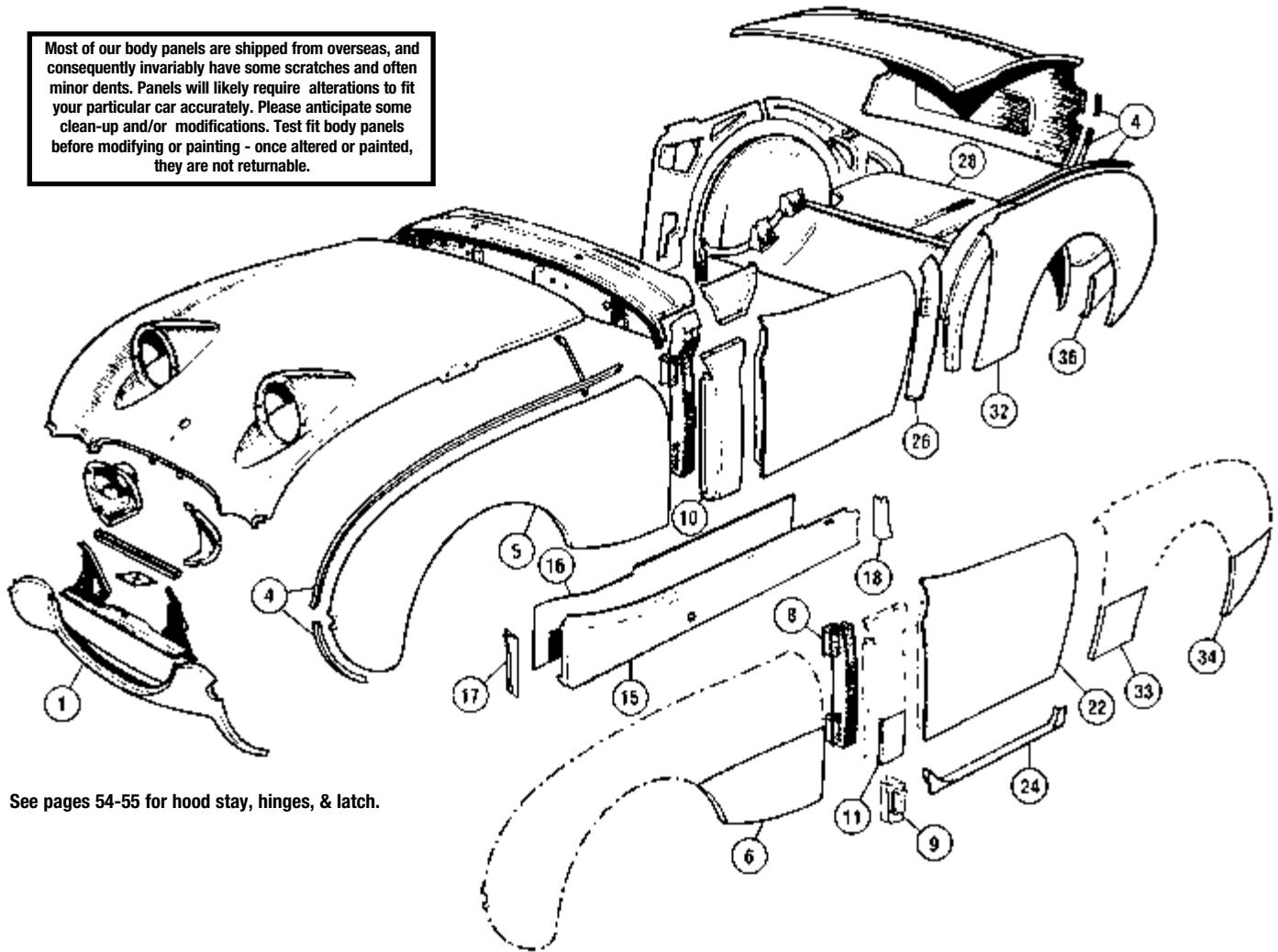

See pages 54-55 for hood stay, hinges, & latch.

No.	Part No.	Price (each)	Description	Application	Qty. Req.
-----	----------	--------------	-------------	-------------	-----------

## Bugeye Body Panels

Underlined part numbers indicate an Oversize Parts Fee will be charged. See [mossmotors.com](http://mossmotors.com) or call for details.

1	452-110	NA	VALANCE, lower front		1
4	<u>457-990</u>	\$33.99	FENDER BEADING	66" length	A/R
5	455-680	NA	FRONT FENDER, L/H		1
	455-670	NA	FRONT FENDER, R/H		1
6	452-120	\$35.99	REPAIR PANEL, L/H		1
	452-125	\$35.99	REPAIR PANEL, R/H		1
8	452-130	\$45.99	"A" POST, inner, L/H, lower 16"		1
	452-135	\$45.99	"A" POST, inner, R/H, lower 16"		1
9	455-065	\$14.99	HINGE MOUNT, lower, L/H		1
	455-055	\$14.99	HINGE MOUNT, lower, R/H		1
10	452-645	\$46.99	"A" POST, outer skin, L/H	} as illus. w/flange	1
	452-655	\$46.99	"A" POST, outer skin, R/H		1
11	455-280	\$4.39	REPAIR PIECE, lower 7 1/2"		2
15	<u>455-495</u>	\$99.99	OUTER SILL, L/H		1
	455-490	\$99.99	OUTER SILL, R/H		1
16	<u>455-445</u>	\$24.49	INNER SILL, L/H	} late type with 2 holes	1
	455-440	\$24.49	INNER SILL, R/H		1
17	452-150	\$28.99	END CAP, front, L/H	British Motor Heritage	1
	452-310	\$7.49	END CAP, front, L/H	aftermarket	1
	452-155	\$28.99	END CAP, front, R/H	British Motor Heritage	1
	452-300	\$7.49	END CAP, front, R/H	aftermarket	1
18	452-160	\$28.99	END CAP, rear, L/H	British Motor Heritage	1
	452-315	\$7.49	END CAP, rear, L/H	aftermarket	1
	452-165	\$28.99	END CAP, rear, R/H	British Motor Heritage	1
	452-305	\$7.49	END CAP, rear, R/H	aftermarket	1
22	<u>452-170</u>	\$209.99	DOOR SKIN, L/H		1
	<u>452-175</u>	\$209.99	DOOR SKIN, R/H		1
24	452-180	\$47.99	REPAIR PIECE, inner door bottom, L/H		1
	452-185	\$47.99	REPAIR PIECE, inner door bottom, R/H		1
26	455-650	\$74.99	"B" POST FACE, L/H		1
	455-640	\$74.99	"B" POST FACE, R/H		1
28	452-190	\$164.99	TRUNK FLOOR		1

No.	Part No.	Price (each)	Description	Application	Qty. Req.
-----	----------	--------------	-------------	-------------	-----------

32	455-700	NA	REAR FENDER, L/H		1
	455-690	NA	REAR FENDER, R/H		1
33	452-200	\$19.89	REPAIR PANEL, front, L/H		1
	452-205	\$19.89	REPAIR PANEL, front, R/H		1
34	452-210	\$179.99	REPAIR PANEL, rear, L/H		1
	452-215	\$179.99	REPAIR PANEL, rear, R/H		1
36	452-220	\$32.99	CLOSING PANEL, trunk to fender, L/H		1
	452-225	\$32.99	CLOSING PANEL, trunk to fender, R/H		1

## Common Areas of Corrosion

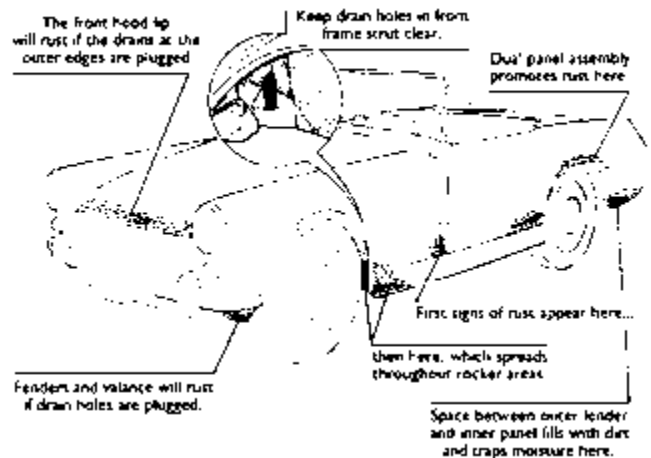

MOSS

MOSS MOTORS, LTD.  
TOLL-FREE ORDERS

1-800-667-7872

Most of our body panels are shipped from overseas, and consequently invariably have some scratches and often minor dents. Panels will likely require alterations to fit your particular car accurately. Please anticipate some clean-up and/or modifications. Test fit body panels before modifying or painting - once altered or painted, they are not returnable.

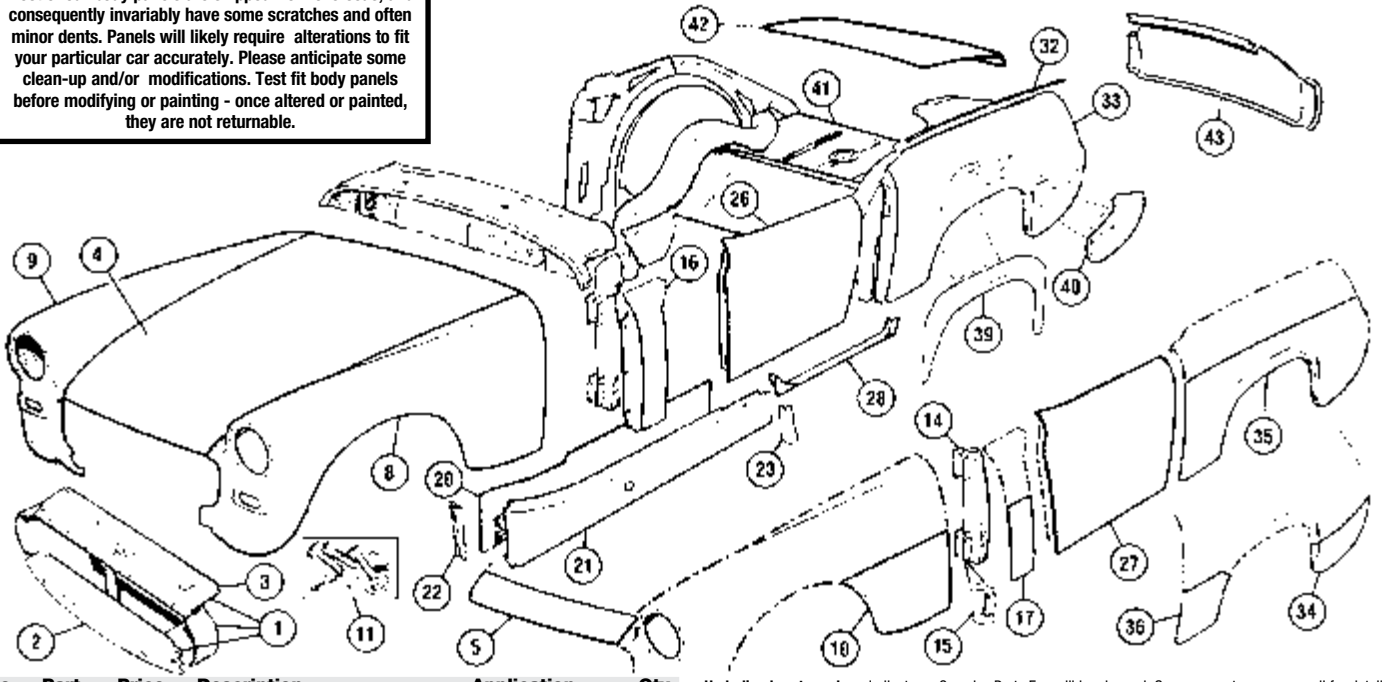

No.	Part No.	Price (each)	Description	Application	Qty. Req.		
<b>Body Panels (except Bugeye Sprite)</b>							
1	455-145	\$469.99	FRONT PANEL ASSEMBLY, BMH*	except 1500	1		
	455-155	\$449.99	FRONT PANEL ASSEMBLY, BMH*	1500	1		
2	455-190	\$234.99	VALANCE PANEL, front, BMH*	except 1500	1		
	452-430	\$194.89	VALANCE PANEL, front	1500	1		
3	455-165	\$84.79	HOOD LATCH PANEL	except 1500	1		
	455-345	NA	HOOD LATCH PANEL	1500	1		
4	455-290	\$929.99	HOOD, BMH*	Midget to (c)183739 (Has provision for all hood stay configurations) all Sprite	1		
	455-790	\$829.99	HOOD, BMH*			Midget from (c)183740	
5	455-200	NA	REPAIR PANEL, hood "skin"	} all	1		
	452-240	NA	REPAIR PANEL, inner hood				
8	455-710	\$899.99	FRONT FENDER, L/H, BMH*	} AH MkII thru 1968	1		
9	455-715	\$899.99	FRONT FENDER, R/H, BMH*				
	455-720	\$899.99	FRONT FENDER, L/H, BMH*	} 1275 from '69-'74	1		
	455-725	\$899.99	FRONT FENDER, R/H, BMH*				
	455-730	\$799.99	FRONT FENDER, L/H, BMH*	} 1500	1		
	455-735	\$799.99	FRONT FENDER, R/H, BMH*				
10	455-265	\$33.79	REPAIR PANEL, L/H	} except 1500	1		
	455-260	\$33.79	REPAIR PANEL, R/H				
	455-275	\$33.79	REPAIR PANEL, L/H	} 1500	1		
	455-270	\$33.79	REPAIR PANEL, R/H				
11	322-995	\$7.89	HARDWARE KIT, ft. fender mounting		2		
14	452-130	\$45.99	"A" POST ASSEMBLY, L/H	} thru 1968 (lower 16")	1		
	452-135	\$45.99	"A" POST ASSEMBLY, R/H				
	455-185	\$42.99	"A" POST ASSEMBLY, L/H	} from 1969 on (lower 16")	1		
	455-195	\$42.99	"A" POST ASSEMBLY, R/H				
15	455-065	\$14.99	TAPPING PLATE ASS'Y., lower, L/H	}	1		
	455-055	\$14.99	TAPPING PLATE ASS'Y., lower, R/H				
16	452-645	\$46.99	OUTER SKIN, "A" post, L/H	} side curtain cars	1		
	452-655	\$46.99	OUTER SKIN, "A" post, R/H				
	455-665	\$58.99	OUTER SKIN, "A" post, L/H, BMH*	} wind-up window cars	1		
	455-675	\$58.99	OUTER SKIN, "A" post, R/H, BMH*				
17	455-280	\$4.39	REPAIR PANEL, lower 7 1/2"		2		
20	455-445	\$24.49	INNER SILL, L/H	} late type with 2 holes	1		
	455-440	\$24.49	INNER SILL, R/H				
21	455-495	\$99.99	OUTER SILL, L/H, 1 jack point			} except 1500	1
	455-490	\$99.99	OUTER SILL, R/H, 1 jack point				
	455-025	\$104.99	OUTER SILL, L/H, 2 jack points	} 1500	1		
	455-015	\$104.99	OUTER SILL, R/H, 2 jack points				

Underlined part numbers indicate an Oversize Parts Fee will be charged. See [mossmotors.com](http://mossmotors.com) or call for details.

22	452-150	\$28.99	END CAP, front, L/H, BMH*		1
	452-310	\$7.49	END CAP, front, L/H, aftermarket		1
	452-155	\$28.99	END CAP, front, R/H, BMH*		1
	452-300	\$7.49	END CAP, front, R/H, aftermarket		1
23	452-160	\$28.99	END CAP, rear, L/H, BMH*		1
	452-315	\$7.49	END CAP, rear, L/H, aftermarket		1
	452-165	\$28.99	END CAP, rear, R/H, BMH*		1
	452-305	\$7.49	END CAP, rear, R/H, aftermarket		1
26	452-260	NA	DOOR ASSEMBLY, L/H, BMH*	} wind-up window cars	1
	452-270	NA	DOOR ASSEMBLY, R/H, BMH*		
27	<u>452-170</u>	\$209.99	DOOR SKIN, L/H	} side curtain cars	1
	<u>452-175</u>	\$209.99	DOOR SKIN, R/H		
	452-250	\$109.99	DOOR SKIN, L/H, BMH*	} wind-up window cars	1
	455-035	\$109.99	DOOR SKIN, R/H, BMH*		
28	452-180	\$47.99	REPAIR PIECE, inner door bottom, L/H	} all	1
	452-185	\$47.99	REPAIR PIECE, inner door bottom, R/H		
32	<u>457-990</u>	\$33.99	FENDER BEADING, 66" length		A/R
33	455-915	\$879.99	REAR FENDER, L/H	} Sprite MkII & Midget MkI	1
	455-925	\$879.99	REAR FENDER, R/H		
	455-945	NA	REAR FENDER, L/H	} Sprite MkIII & Midget MkII	1
	455-955	NA	REAR FENDER, R/H		
	455-795	\$519.99	REAR FENDER, L/H, BMH*	} 1275 square arch to January 1972	1
	455-750	\$519.99	REAR FENDER, R/H, BMH*		
	455-765	\$479.99	REAR FENDER, L/H, BMH*	} 1275 round arch GAN5-105501 to 123730	1
	455-760	\$479.99	REAR FENDER, R/H, BMH*		
	455-775	NA	REAR FENDER, L/H	} 1275 square arch GAN5-123730 to 153290	4
	455-770	NA	REAR FENDER, R/H		
	455-785	\$519.99	REAR FENDER, L/H	} 1500	1
	455-780	NA	REAR FENDER, R/H		
34	455-705**	\$54.99	REPAIR PANEL, rear of L/H fender	} chrome bumper cars	1
	455-695**	\$54.99	REPAIR PANEL, rear of R/H fender		
35	<u>455-115</u>	\$299.99	REPAIR PANEL, L/H rear wheel arch	} (square arch only)	1
	<u>455-105</u>	\$299.99	REPAIR PANEL, R/H rear wheel arch		
36	455-135	\$32.99	REPAIR PANEL, L/H		1
	455-125	\$32.99	REPAIR PANEL, R/H		1
39	455-095	\$98.89	REPAIR PANEL, L/H inner wheel arch	} (square arch only)	1
	455-085	\$98.89	REPAIR PANEL, R/H inner wheel arch		
40	455-805**	\$54.99	CLOSING PANEL, trunk to fender, L/H, BMH*		1
	455-815**	\$54.99	CLOSING PANEL, trunk to fender, R/H, BMH*		1
41	452-195	\$274.99	TRUNK FLOOR, BMH*		1
42	455-895	\$389.99	TRUNK LID, BMH*		1
43	<u>455-995</u>	\$189.99	REAR APRON PANEL, BMH*	1961-'69	1
	456-505	\$179.99	REAR APRON PANEL, BMH*	1970-'74	1
	455-395	NA	REAR APRON PANEL, BMH*	1500	1

\* Parts marked "BMH" are produced by British Motor Heritage.  
\*\* Fits thru 1974, but may be modified for rubber bumper cars

**LOCAL & OVERSEAS: 805-681-3400**  
**FAX: 805-692-2525** [www.mossmotors.com](http://www.mossmotors.com)



# Inner Body Panels

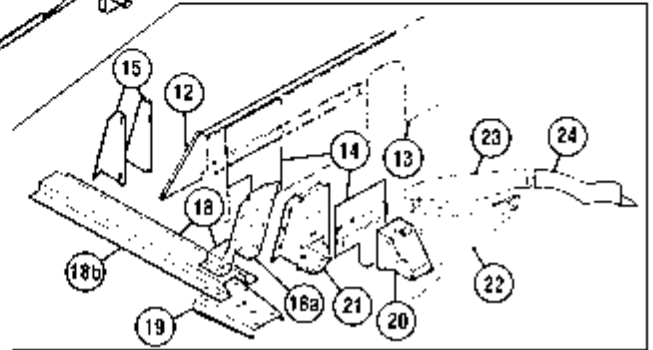
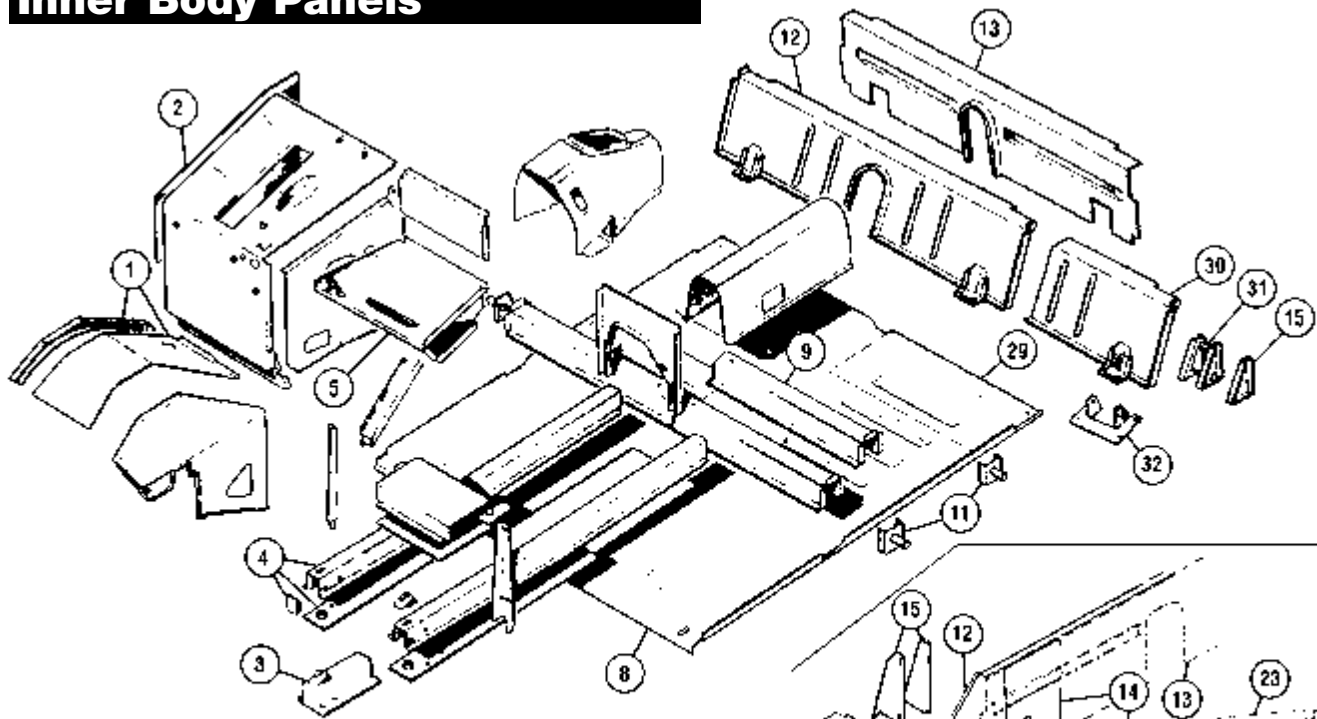

No.	Part No.	Price (each)	Description	Application	Qty. Req.
-----	----------	--------------	-------------	-------------	-----------

## Internal Body Panels

1	455-225	\$49.99	WHEEL ARCH, front, R/H (as illus.)	} Bugeye	1
	455-235	\$49.99	WHEEL ARCH, front, L/H (as illus.)		1
	455-245	NA	WHEEL ARCH, front, R/H (as illus.)	} except Bugeye	1
	455-255	\$54.99	WHEEL ARCH, front, L/H (as illus.)		1
2	455-210	\$52.99	PANEL, outer side of footwell, R/H, BMH**		1
	455-215	\$52.99	PANEL, outer side of footwell, L/H, BMH**		1
3	455-505	\$53.99	FRAME SECTION, front, R/H	} Bugeye	1
	455-515	\$53.99	FRAME SECTION, front, L/H		1
4	455-525	\$104.99	FRAME RAIL, complete, R/H, BMH**	} all except Bugeye	1
	455-535	\$104.99	FRAME RAIL, complete, L/H, BMH**		1
5	455-236	\$109.99	SHELF, battery & heater, BMH**	1967-'70	1
	455-237	\$109.99	SHELF, battery & heater, BMH**	1971-'80	1
8	455-408	\$419.99	FLOOR PAN, BMH**	1500, but fits all (Complete floor, has hole at rear of gearbox for U-joint access.)	1
	455-625	\$169.99	FLOOR PAN REPAIR, R/H*	} Sprite Mkl - MkII	1
455-635	\$169.99	FLOOR PAN REPAIR, L/H*	} Midget Mkl		1
	455-410	\$149.99	FLOOR PAN REPAIR, R/H*	} Sprite Mk III on	1
	455-415	\$149.99	FLOOR PAN REPAIR, L/H*		} Midget MkII on
* Aftermarket parts supplied.					

9	455-005	\$66.99	OUTER CROSS MEMBER SECTION, with jacking point, BMH**2 (approx. 2/5 of total crossmember length)		
11	455-555	NA	JACKING POINT, rear L/H	} 1500 from (c)157672	2
	455-845	\$24.99	JACKING POINT, rear R/H		2
12	455-590	\$174.99	BULKHEAD, rear cockpit	Sprite Mkl & Midget Mkl, II	1
	455-645	\$94.99	BULKHEAD, rear cockpit, BMH**	Sprite MkII, Midget MkIII on 1	1
13	455-565	\$109.99	SHUT PANEL, BMH**		1
14	455-530	\$49.99	REPAIR PIECE, shut panel end		2
15	455-660	\$19.89	REINFORCEMENT PAIR, between # 12 & 13.		A/R
18	455-520†	\$118.99	REINFORCEMENT SET, bulkhead/floor	} Sprite Mkl, II	2
	455-975	\$89.99	BRACE		} Midget I
18b	455-985	\$42.99	REINFORCEMENT, floor	} 1/4 elliptic springs	2
19	455-580	\$48.89	BASE PLATE, spring mount		2
20	455-540	\$56.99	BRACKET, radius arm, R/H	}	1
	455-550	\$56.99	BRACKET, radius arm, L/H		1
21	455-500†	\$98.99	SPRING HANGER BOX	Bugeye	2
	455-510	\$92.99	SPRING HANGER BOX	Sprite MkII, Midget Mkl	2

No.	Part No.	Price (each)	Description	Application	Qty. Req.
22	455-560	\$44.99	SHOCK MOUNTING BRACKET, R/H	} Sprite Mkl, II	1
	455-566	\$44.99	SHOCK MOUNTING BRACKET, L/H		} Midget I
	455-576	\$49.99	SHOCK MOUNTING BRACKET, R/H, BMH**	} Sprite Mk III on 1	1
	455-570	\$49.99	SHOCK MOUNTING BRACKET, L/H, BMH**		} Midget MkII on 1
23	455-600	\$53.99	REPAIR PANEL, wheel well, R/H		1
	455-610	\$53.99	REPAIR PANEL, wheel well, L/H		1
24	455-620	NA	REPAIR PANEL, wheel well, R/H		1
	455-630	NA	REPAIR PANEL, wheel well, L/H		1
29	455-465	NA	REPAIR PANEL, rear floor, L/H	} Sprite Mkl - MkII	1
	455-475	NA	REPAIR PANEL, rear floor, R/H		} Midget Mkl
	455-425	\$24.79	REPAIR PANEL, rear floor, L/H	} Sprite MkIII - on	1
	455-420	\$24.79	REPAIR PANEL, rear floor, R/H		} Midget MkII - on
30	455-435	\$32.79	BULKHEAD REPAIR PANEL, L/H	}	1
	455-205	\$32.79	BULKHEAD REPAIR PANEL, R/H		1/2 elliptic springs
31	455-605	\$94.99	SPRING HANGER BOX, BMH**		2
32	455-615	\$23.99	SPRING MOUNTING PLATE		2

\*\* Parts marked "BMH" are produced by British Motor Heritage.

† These parts are designed to be bolted together as sets prior to welding, making proper alignment easier. However, they are not meant to be bolted without being welded.

# Windshields

## Sprite Mkl & MkII, Midget Mkl

Underlined part numbers indicate an Oversize Parts Fee will be charged. See mossmotors.com or call for details.

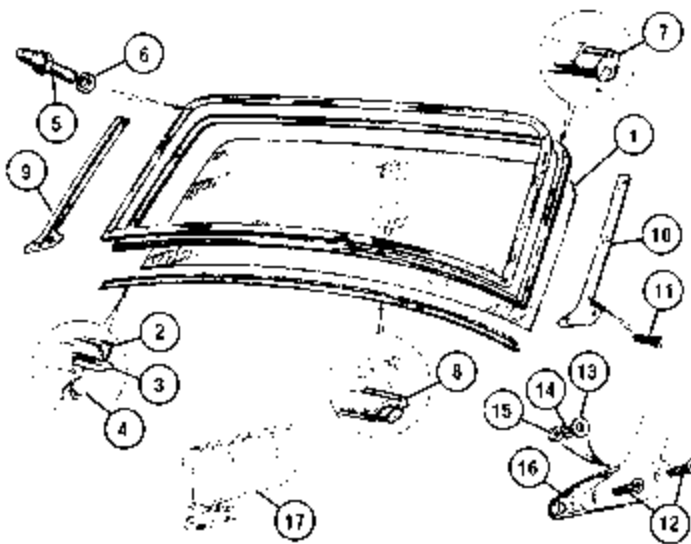

Early Bugeye windshield frames to (c)5476 had 9 Lift-the-Dot studs across the top rail. Later frames had two, one at each corner. The threaded shanks on the later studs were shorter than on the early ones, and care must be used with replacement studs lest they crack the glass. Test fit before installing the glass, and shorten them if need be. Early windshield glass measured 295mm high by 1205mm wide, while the later one measures 287mm high by 1180mm wide.

1	<u>459-905</u>	\$199.99	WINDSHIELD GLASS		Bugeye to (c)5476	1
	<u>459-900</u>	\$159.99	WINDSHIELD GLASS		Sprite from (c)5477 Midget Mkl	1
2	282-005	\$28.99	GLAZING RUBBER		} Bugeye to (c)5476	1
3	282-000	NA	PACKING RUBBER			1
4	680-875	\$15.99	SEAL, windshield to body			1
5	226-600	\$1.99	STUD			9
	226-600	\$1.99	STUD			2
6	310-040	\$0.19	NUT		} Sprite from (c)5477 Midget Mkl	2
7	281-990	\$51.49	GLAZING RUBBER, with filler strip			1
	282-445	\$12.99	FILLER STRIP, glazing rubber			1
8	680-870	\$9.79	SEAL, windshield to body			1
9	453-935	\$92.99	PILLAR, R/H			1
10	453-940	\$92.99	PILLAR, L/H		1	
11	314-270	\$0.69	SCREW, pillar to frame		6	
12	323-125	\$2.69	SCREW, pillar to body, zinc plated	(original type)	4	
	323-135	\$3.79	SCREW, pillar to body, chromed	(optional)	4	
13	324-155	\$0.39	WASHER, flat		} rear position only	2
14	365-730	\$0.25	SPRING WASHER			2
15	310-140	\$0.24	NUT			2
16	680-880	\$7.89	PAD SET, pillar to body (pair)			1
17	165-280	\$53.99	MIRROR, interior			1
	472-507	\$0.89	SCREW, mirror		2	

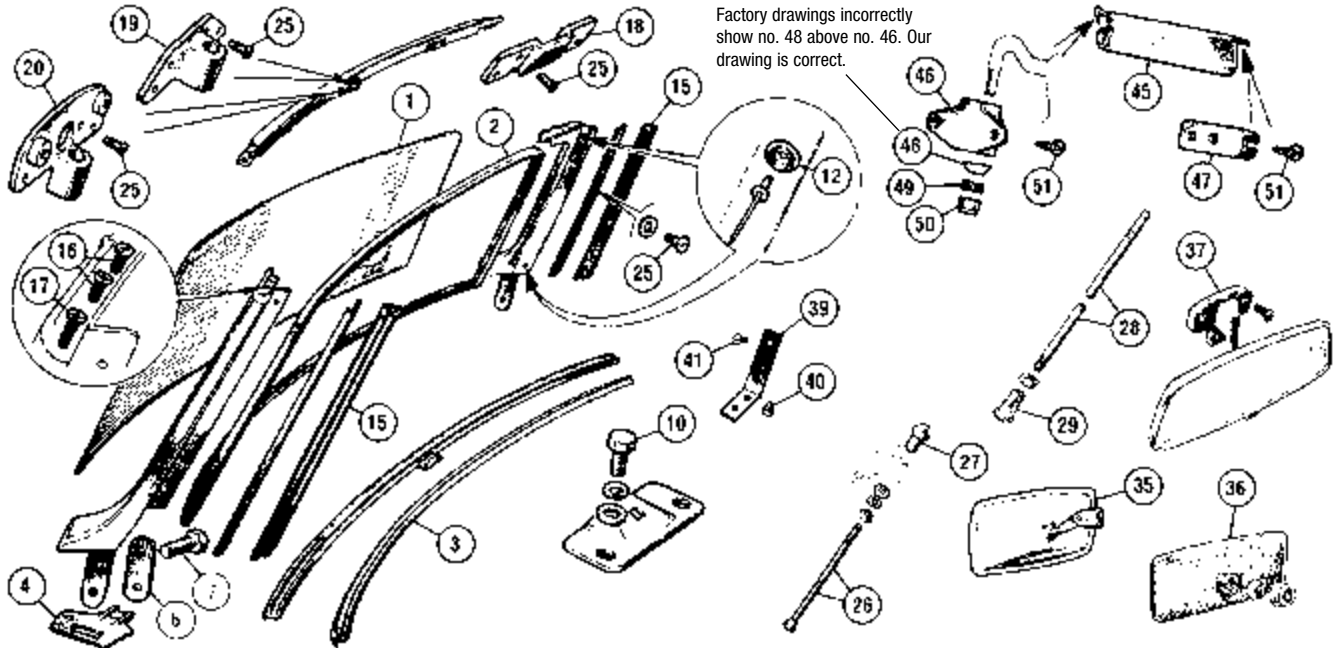

No.	Part No.	Price (each)	Description	Application	Qty. Req.
1	<u>459-915</u>	\$499.99	WINDSHIELD GLASS, Triplex		1
	<u>459-910</u>	\$123.99	WINDSHIELD GLASS		1
2	281-995	\$19.99	GLAZING SEAL		1
3	282-025	\$16.69	SEAL, windshield to body		1
4	282-055	\$4.99	SEAL, windshield pillar to body, LH		1
	282-045	\$4.99	SEAL, windshield pillar to body, RH		1
6		NA	SHIM, pillar leg to 'A' post		A/R
7	116-162	\$1.69	BOLT, upper		2
	322-615	\$2.69	BOLT, lower		2
10	314-275	\$1.89	BOLT, center rod bracket to body		2
12	226-720	\$0.29	STUD, top & tonneau attachment		4
15	282-210	\$5.59	SEAL, pillar to quarter light	1967-1977	2
	282-265	\$5.99	SEAL, pillar to quarter light	1978-on	2
16	408-056	\$0.49	SCREW, top rail to pillar (inner positions)		4
17	408-057	\$0.39	SCREW, top rail to pillar (outer position)		2
18	472-620	NA	BRACKET, top fastening, satin finish		2
19		NA	BRACKET, center rod, upper	1967-1969	1

### from Sprite MkIII, Midget MkII on

Underlined part numbers indicate an Oversize Parts Fee will be charged. See mossmotors.com or call for details.

20	472-415	NA	BRACKET, center rod and mirror, upper	1970-on	1
25	325-277	NA	RIVET, brackets & seal retainer		34
26	472-435	\$8.99	CENTER ROD, chrome	} 1967-1969	1
27	472-635	\$3.39	NUT, domed		1
28	472-445	\$2.89	CENTER ROD, silver painted	} 1970-on	1
29	472-640	\$1.19	NIPPLE, lower		1
35	165-110	\$23.99	INTERIOR MIRROR, metal	Sprite to (c)63074 Sprite to (c)74461	1
36		NA	INTERIOR MIRROR, plastic	Midget (c) 63075-75885 Sprite (c)74462-on Midget (c)75886-on	1
37	165-115	\$38.99	INTERIOR MIRROR		1
39	400-620	NA	BRACKET SET, frame corners		1
40	408-056	\$0.49	SCREW, bottom rail to bracket		4
41	408-055	\$0.49	SCREW, pillar to bracket		4
45	233-340	\$29.99	SUN VISOR, R/H	} thru 1976	1
	233-350	\$29.99	SUN VISOR, L/H		1
	233-341	\$29.99	SUN VISOR, RH		} 1977-'80
	233-351	\$23.99	SUN VISOR, LH	1	
46	233-921	\$19.99	PIVOT BRACKET, sun visor	thru 1976	2
	233-920	\$18.49	PIVOT BRACKET, sun visor	1977-'80	2
47	233-930	\$1.19	STAY BRACKET, sun visor		2
48	324-175	\$0.39	WASHER, spherical		2
49	324-185	\$0.29	WASHER, Thackery		2
50	310-830	\$0.24	NUT, nyloc		2
51	314-280	\$0.49	SCREW, alternative to orig. rivet		8

**LOCAL & OVERSEAS: 805-681-3400**

**FAX: 805-692-2525 www.mossmotors.com**

**MOSS**

# Body Fittings, Bugeye

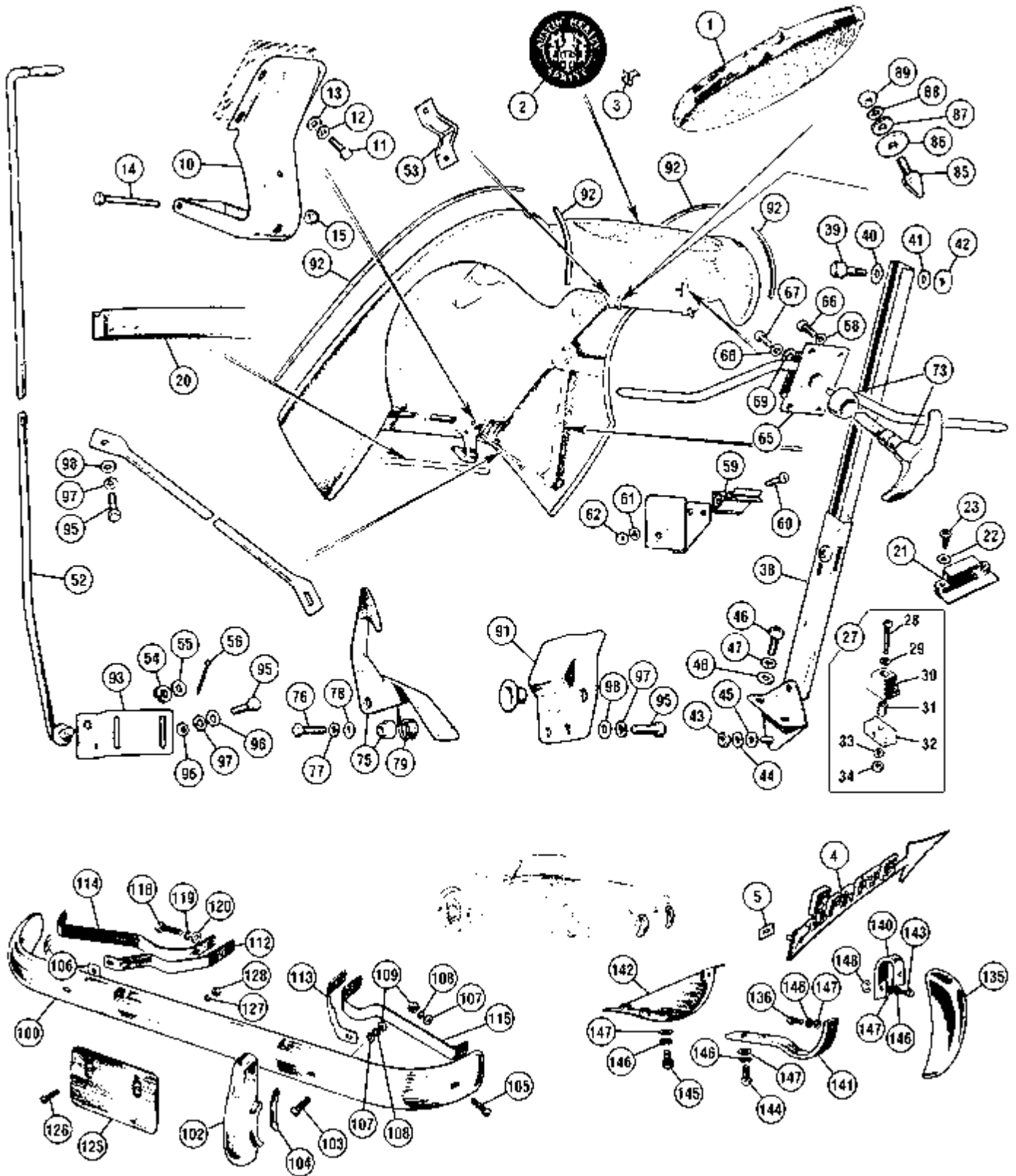

**MOSS**

MOSS MOTORS, LTD.  
TOLL-FREE ORDERS

**1-800-667-7872**





No.	Part No.	Price (each)	Description	Application	Qty. Req.
<b>Grille &amp; Badges</b>					
1	459-770	\$368.99	GRILLE (includes mounting clips)		1
	326-510	\$0.24	CLIP, grille mounting		13
2	031-590	\$39.99	MEDALLION, hood		1
3	326-535	\$0.69	CLIP for medallion		3
4	031-585	\$18.99	BADGE, rear deck, gold color (as original)		1
	031-580	NA	BADGE, rear deck, chromed (alternative)		1
5	326-665	\$0.29	CLIP for badge		2
<b>Hood Fittings</b>					
10	455-835	\$69.99	HINGE, BMH*		2
11	322-645	\$0.49	BOLT		8
12	324-020	\$0.20	LOCKWASHER		8
13	324-590	\$0.19	WASHER		8
14	320-225	\$0.89	BOLT, hinge pin		2
15	311-005	\$0.89	NUT, standard	} alternatives	2
	310-290	\$0.69	NUT, nylon		2
20	282-105	\$20.79	SEAL, hood rear		1
21	282-110	\$3.99	BUFFER, hood		4
22	315-075	\$0.19	WASHER		8
23	372-950	\$0.39	SCREW		8
27	282-098	\$23.99	BUFFER ASSEMBLY		2
28	314-005	\$1.19	SCREW		2
29	324-990	\$0.29	WASHER		2
30	282-125	\$2.39	BUFFER, wheel arch		2
31	282-126	\$5.49	DISTANCE TUBE		2
32	282-215	\$15.99	SPACER		2
33	324-010	\$0.19	LOCKWASHER		2
34	310-040	\$0.19	NUT		2
38	406-980	\$74.79	STAY, hood		2
39	313-010	\$5.89	BOLT, stay to hood		2
40	365-735	\$0.29	WASHER, anti-rattle		2
41	365-720	\$0.29	WASHER, small		2
42	315-110	\$0.49	WASHER, large		2
43	310-040	\$0.19	NUT		2
44	324-010	\$0.19	LOCKWASHER		2
45	315-085	\$0.14	WASHER		2
46	322-495	\$0.49	SCREW		4
47	324-020	\$0.20	LOCKWASHER		4
48	324-590	\$0.19	WASHER		4
52	406-990	\$31.99	STAY, auxilliary		1
53	NA		CLIP		1
54	315-180	\$0.39	LOCKWASHER		1
55	365-720	\$0.29	WASHER		1
56	325-330	\$0.19	COTTER PIN		1
59	471-130	\$5.79	CLIP		1
60	314-010	\$0.24	SCREW		2
61	324-010	\$0.19	LOCKWASHER		2
62	310-040	\$0.19	NUT		2
65	401-890	\$109.99	LOCK ROD ASS'Y.		1
66	323-005	\$0.39	SCREW		4
67	NA		SCREW		4
68	324-010	\$0.19	LOCKWASHER		5
69	315-085	\$0.14	WASHER		5
73	401-870	\$73.99	HANDLE & ESCUTCHEON		1
75	401-880	\$27.99	SAFETY CATCH & BUSH		1
76	322-247	\$0.49	BOLT		1
77	324-020	\$0.20	LOCKWASHER		1
78	324-590	\$0.19	WASHER		1
79	329-880	\$4.89	SPRING		1
85	282-120	\$9.99	PEG, locating		2
86	NA		WASHER, rubber		2
87	315-095	\$0.39	WASHER		2
88	365-730	\$0.25	LOCKWASHER		2
89	310-140	\$0.24	NUT		2
91	400-650	\$22.99	BRACKET, hood lock, R/H		1
	400-660	\$22.99	BRACKET, hood lock, L/H		1
92	457-990	\$33.99	FENDER BEADING (supplied in straight 66" length)	A/R	
93	400-665	\$10.99	BRACKET, prop rod		1
95	322-645	\$0.49	BOLT	A/R	
96	310-760	\$0.39	NUT	A/R	
97	324-020	\$0.20	LOCKWASHER	A/R	
98	324-590	\$0.19	WASHER	A/R	

\* Parts market "BMH" are produced by British Motor Heritage.

**LOCAL & OVERSEAS: 805-681-3400**  
**FAX: 805-692-2525** [www.mossmotors.com](http://www.mossmotors.com)

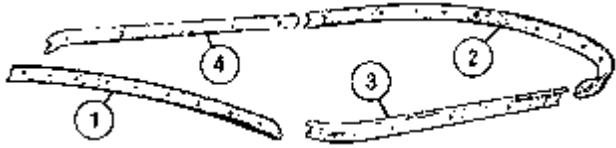

# Body Fittings, Bugeye

No.	Part No.	Price (each)	Description	Application	Qty. Req.
<b>Front Bumper</b>					
100	400-170	\$469.99	BUMPER BAR, front		1
102	454-010	\$68.99	OVERRIDER		2
103	NA		BOLT, overrider (for repl. overriders)		2
	322-900	\$1.89	BOLT, overrider (for orig. overriders)		2
104	400-404	\$0.79	PACKING, overrider		4
105	322-900	\$1.89	BUMPER BOLT		2
106	400-300	\$1.89	PACKING PIECE		4
107	324-860	\$0.19	WASHER		4
108	324-040	\$0.29	LOCKWASHER		4
109	310-050	\$0.59	NUT		4
112	400-175	\$31.49	BUMPER BRACKET	RH Inner	1
113	400-180	\$31.49	BUMPER BRACKET	LH Inner	1
114	400-185	\$34.79	BUMPER BRACKET	RH Outer	1
115	400-190	\$34.79	BUMPER BRACKET	LH Outer	1
118	322-075	\$0.89	BOLT		4
119	324-040	\$0.29	LOCKWASHER		4
120	324-860	\$0.19	WASHER		4
125	451-285	\$9.89	LICENSE PLATE BACKING		1
126	322-645	\$0.49	SCREW		2
127	324-020	\$0.20	LOCKWASHER		2
128	310-760	\$0.39	NUT		2
<b>Rear Overriders</b>					
135	400-210	\$78.99	OVERRIDER		2
136	322-040	\$0.49	BOLT, overrider to bracket		2
140	400-220	\$7.99	BRACKET, upper		4
141	400-230	\$9.99	BRACKET, lower		2
142	455-935	\$20.99	BRACKET, inner		2
143	322-540	\$0.69	SCREW, upper		2
144	322-040	\$0.49	SCREW, lower		4
145	313-000	\$0.24	SCREW, locating		2
146	365-730	\$0.25	LOCKWASHER		12
147	365-720	\$0.29	WASHER		12
148	681-300	\$0.79	PAD, rubber		2
					
1	459-940	\$99.99	CAPPING, dash		1
2	459-941	\$199.99	CAPPING, rear cockpit		1
3	459-942	\$74.99	CAPPING, L/H door top		1
4	459-943	\$74.99	CAPPING, R/H door top		1
	459-944	\$7.99	SCREW KIT, cockpit cappings		1
					
<b>Bugeye Luggage Rack</b>					
Increase your cargo carrying capacity with this traditionally styled luggage rack. This rack mounts permanently with the included hardware and rubber mounting strips. Approx. 39" x 18".					
<b>244-720 \$409.99</b>					
					
<b>License Plate Plinth</b>					
For Bugeyes without front bumpers, this is the official factory means of mounting your number plate. (Home market cars had front bumpers as an optional accessory, so this was an important item for those cars.)					
<b>400-625 \$84.99</b>					

# Front Body Fittings 1961-'80

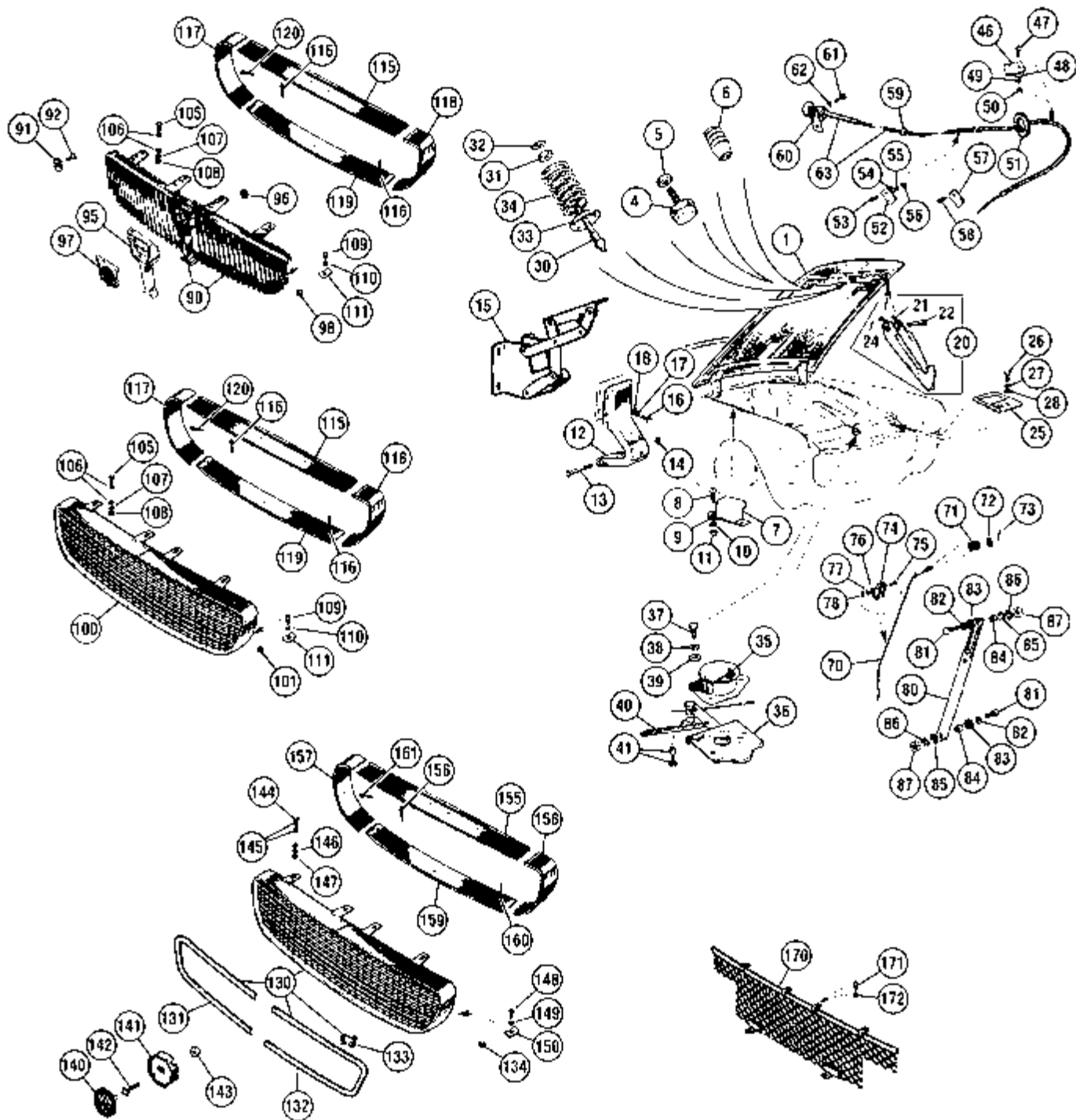

No.	Part No.	Price (each)	Description	Application	Qty. Req.
<b>Hood</b>					
1			HOOD ASSEMBLY	See page 53	1
4	282-130	\$2.89	BUFFER, front corner	} Midget to (c)183739 } all Sprite	2
5	848-540	\$0.19	NUT, locking		2
6	282-190	\$2.79	BUFFER, front corner	Midget from (c)183740	2
7	282-115	\$2.89	BUFFER, side		2
8	323-005	\$0.39	SCREW, buffer to fender drainage channel		4
9	315-085	\$0.14	WASHER, plain		4
10	324-010	\$0.19	WASHER, locking		4
11	310-040	\$0.19	NUT		4

No.	Part No.	Price (each)	Description	Application	Qty. Req.
12	455-835	\$69.99	HINGE, hood, BMH*	} Sprite to (c)77590 } Midget to (c) 66225	2
13	320-225	\$0.89	BOLT, hinge to bulkhead		2
14	310-105	\$0.39	NUT, nyloc		2
15	455-875	NA	HINGE, hood, R/H	} from Sprite MkIV(c)77591 on } from Midget MkIII (c)66226 on	1
	455-885	NA	HINGE, hood, L/H		1
16	322-645	\$0.49	BOLT, hinge to hood		8/4
17	324-020	\$0.20	WASHER, locking		8/4
18	324-590	\$0.19	WASHER, plain		8/4

\* Parts marked "BMH" are produced by British Motor Heritage.

**MOSS**

**MOSS MOTORS, LTD.**  
TOLL-FREE ORDERS

**1-800-667-7872**

# Front Body Fittings 1961-'80

No.	Part No.	Price (each)	Description	Application	Qty. Req.
20	470-640	\$17.99	HOOK ASS'Y, safety catch		1
21	329-325	\$4.29	SPRING, hook return		1
22		NA	CLEVIS PIN		1
24	325-005	\$0.10	SPLIT PIN		1
25	406-020	\$4.49	BRACKET, safety catch		1
26	466-385	\$0.39	SCREW, bracket to landing panel		2
27	324-010	\$0.19	WASHER, locking		2
28	315-085	\$0.14	WASHER, plain		2
30	406-000	\$6.79	PIN		1
31	310-070	\$0.39	NUT, locking pin		1
32	324-040	\$0.29	WASHER, locking		1
33	406-055	\$6.79	THIMBLE, pin (British Motor Heritage part)		1
34	406-060	\$1.89	SPRING, bonnet lock		1
35	406-065	\$12.79	CUP, locating		1
36	406-015	\$99.99	CATCH PLATE		1
37	322-645	\$0.49	SCREW, cup and plate to landing panel		3
38	324-020	\$0.20	WASHER, locking		3
39	324-590	\$0.19	WASHER, plain		3
40	406-035	\$2.49	SPRING, catch return		1
41	406-040	\$2.89	TRUNNION & SCREW, hood release cable		1
46	182-600	\$0.89	CLIP, landing panel		1
47	323-005	\$0.39	SCREW, clip		1
48	315-085	\$0.14	WASHER, plain		1
49	324-010	\$0.19	WASHER, locking		1
50	310-040	\$0.19	NUT		1
51	680-630	\$0.89	GROMMET, mud shield		1
52	182-600	\$0.89	CLIP, LH inner wheel arch	} Midget to (c)154100 (1961-'74) all Sprite	1
53	323-005	\$0.39	SCREW, clip to wheel arch		1
54	315-085	\$0.14	WASHER, plain		1
55	324-010	\$0.19	WASHER, locking		1
56	310-040	\$0.19	NUT	1	
57	182-600	\$0.89	CLIP, bumper beam	} Midget 1500	1
58	323-705	\$0.29	SCREW, clip to bumper beam		1
59	281-050	\$5.49	GROMMET, in LH toe board	} Midget to (c)212000 (1961-'78) all Sprite	1
60		NA	BRACKET, footwell side		1
61	314-010	\$0.24	SCREW, footwell side bracket		2
62	324-010	\$0.19	WASHER, locking		2
63	331-700	\$21.49	HOOD RELEASE CABLE, round knob	thru 1977	1
	406-005	\$14.99	HOOD RELEASE CABLE, 'T' handle	1978-on	1
70	406-995	NA	STAY ROD, hood	} Midget to (c)89500 (1961-'70) all Sprite	1
71	329-165	NA	SPRING, anti rattle		1
72	365-720	\$0.29	WASHER, plain		1
73	325-330	\$0.19	COTTER PIN		1
74	471-130	\$5.79	CLIP, stay rod stowage		1
75	314-010	\$0.24	SCREW, clip to hood		2
76	315-085	\$0.14	WASHER, plain		2
77	324-010	\$0.19	WASHER, locking		2
78	310-040	\$0.19	NUT		2
80	457-445	\$28.99	TELESCOPIC STAY, hood		} Midget from (c)89501 (from 1971)
81	314-265	\$0.49	BOLT	2	
82	324-590	\$0.19	WASHER, plain	2	
83	315-060	\$2.79	WASHER, thackery	2	
84	434-370	\$0.89	SPACER	2	
85	324-860	\$0.19	WASHER, plain	2	
86	324-020	\$0.20	WASHER, locking	2	
87	310-760	\$0.39	NUT	2	

No.	Part No.	Price (each)	Description	Application	Qty. Req.
<b>Grilles</b>					
90	459-790	NA	GRILLE ASSEMBLY	} Midget 1961-'69	1
91	326-615	\$1.29	CLIP, slat to frames		76
92	314-280	\$0.49	SCREW, slat to frames		76
95	470-635	NA	PLINTH		1
96	326-530	\$0.24	CLIP, plinth to frames		2
97	201-050	\$15.49	BADGE, 'MG'		1
98		NA	GROMMET		4
100	459-780	\$329.99	GRILLE ASSEMBLY	} Sprite 1961-'69	1
101	472-735	\$0.49	GROMMET		4
105	322-495	\$0.49	SCREW, grille to landing panel	} Sprite & Midget 1961-'69	4
106	324-590	\$0.19	WASHER, plain		8
107	324-020	\$0.20	WASHER, locking		4
108	310-760	\$0.39	NUT		4
109	323-705	\$0.29	SCREW, grille to front valance		2
110	315-295	\$0.49	WASHER, plain		2
111	310-355	\$0.39	SPIRE NUT		2
115	459-620	\$31.29	FINISHER, hood edge		1
116	326-285	\$1.29	RIVET, hood & lower finishers		10
117	459-825	\$25.99	FINISHER, grille aperture, RH side		1
118	459-830	\$25.99	FINISHER, grille aperture, LH side		1
119	459-835	\$34.99	FINISHER, grille aperture, lower		1
120	326-285	\$1.29	RIVET, side finishers to fenders	6	
130	459-800	\$399.99	GRILLE ASSEMBLY	} Midget 1970-74	1
131		NA	MOULDING, grille, RH		1
132		NA	MOULDING, grille, LH		1
133	455-330	\$0.89	CLIP, moulding to grille		8
134	472-235	NA	GROMMET		4
140	201-060	\$11.49	BADGE, 'MG'		1
141	470-675	\$37.99	PLINTH, badge		1
142		NA	STUD PLATE, plinth to grille		1
143	310-625	\$0.29	NUT		1
144	322-495	\$0.49	SCREW, grille to landing panel		4
145	324-590	\$0.19	WASHER, plain		8
146	324-020	\$0.20	WASHER, locking		4
147	310-760	\$0.39	NUT		4
148	323-705	\$0.29	SCREW, grille to valance		2
149		NA	WASHER, plain		2
150	310-355	\$0.39	SPIRE NUT		2
155	459-620	\$31.29	FINISHER, hood edge		1
156	326-285	\$1.29	RIVET, finisher to hood	6	
157	459-840	\$27.99	FINISHER, grille aperture, RH side	1	
158	459-845	\$27.99	FINISHER, grille aperture, LH side	1	
159	459-850	\$33.89	FINISHER, grille aperture, lower	1	
160	326-285	\$1.29	RIVET, lower finisher to valance	4	
161	326-285	\$1.29	RIVET, side finishers to fenders	6	
170	459-810	\$34.79	GRILLE ASSEMBLY	} Midget 1500	1
171	314-070	\$0.29	SCREW, grille mounting		6
172	324-990	\$0.29	WASHER, plain		6



# Rear Body Fittings, 1961-'80

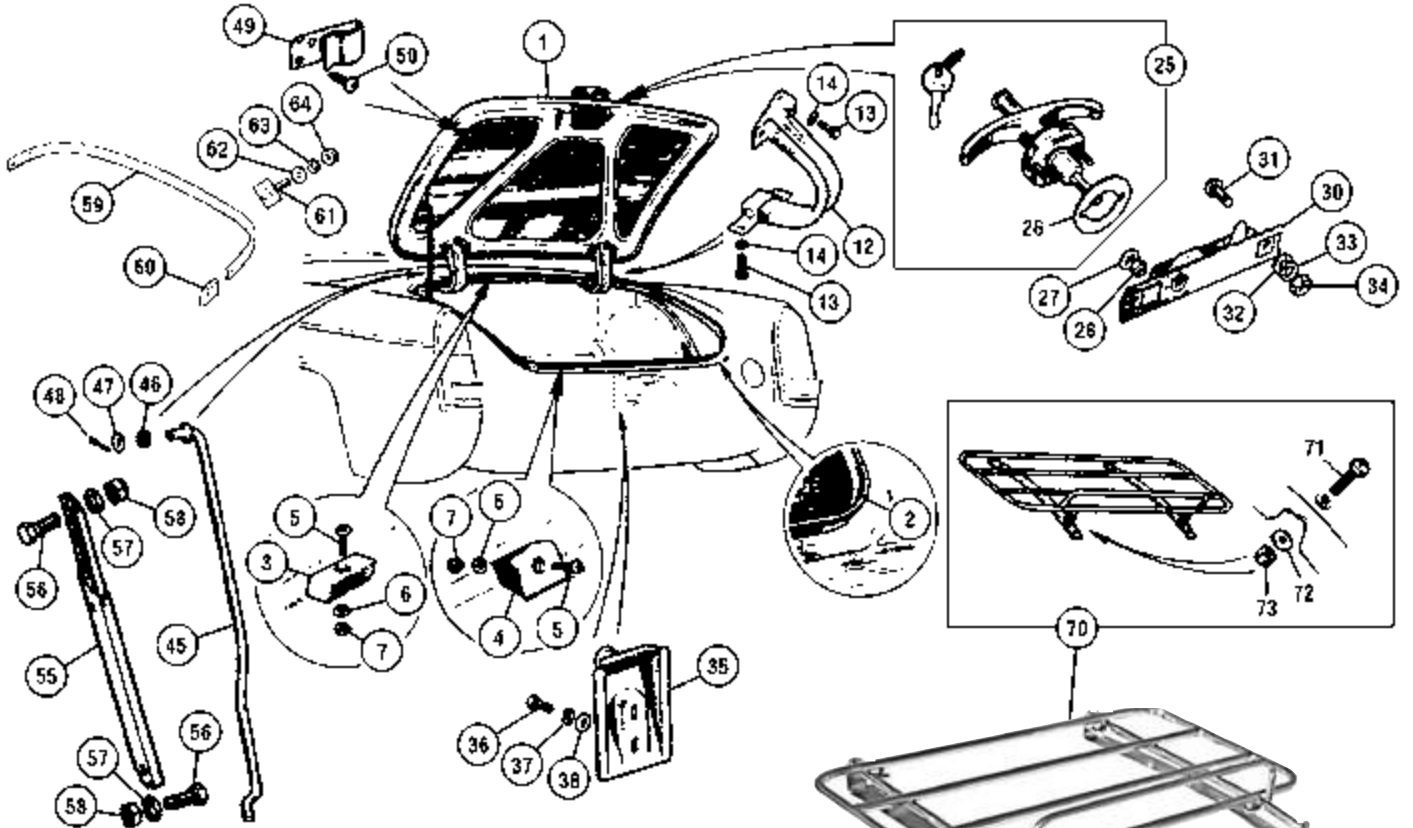

No.	Part No.	Price (each)	Description	Application	Qty. Req.
-----	----------	--------------	-------------	-------------	-----------

## Trunk Fittings

1	455-895	\$389.99	TRUNK LID ASSEMBLY, BMH*		1
2	282-155	\$11.89	SEAL, trunk lid		1
3	380-335	\$2.79	BUFFER, trunk lid, front		2
4	282-160	\$2.99	BUFFER, trunk lid, rear		2
5	314-290	\$0.49	SCREW, buffer to drainage channel		4
6	315-070	\$0.24	WASHER, locking		4
7	310-625	\$0.29	NUT		4
12	405-425	\$74.99	HINGE, trunk lid, RH, BMH*		1
	405-430	\$74.99	HINGE, trunk lid, LH, BMH*		1
13	322-645	\$0.49	BOLT, hinge to trunk lid and rear deck		10
14	324-020	\$0.20	WASHER, locking		10
25	470-445	\$61.79	HANDLE AND LOCK, trunk (with two keys)		1
26	402-525	\$0.89	GASKET, fiber		1
27	315-085	\$0.14	WASHER, plain		2
28	159-340	\$0.49	NUT, securing handle to trunk lid		2
30	470-455	\$19.99	LATCH, trunk lid		1
31	322-880	\$0.49	SCREW, latch to trunk lid		2
32	324-590	\$0.19	WASHER, plain		2
33	324-020	\$0.20	WASHER, locking		2
34	310-760	\$0.39	NUT		2
35	407-005	\$25.99	STRIKER PLATE		1
36	323-005	\$0.39	SCREW, striker plate		2
37	324-010	\$0.19	WASHER, locking		2
38	315-085	\$0.14	WASHER, plain		2
45	407-000	NA	STAY ROD, trunk lid	} Midget thru (c)89500 (to approx. '70) all Sprite (not Bugeye)	1
46	370-460	\$0.59	WASHER, thackery		1
47	324-590	\$0.19	WASHER, plain		1
48	325-330	\$0.19	SPLIT PIN		1
49	457-475	\$6.49	CLIP, stay rod stowage		1
50	323-430	\$0.29	SCREW, clip to trunk lid		2
55	407-010	\$38.99	STAY, trunk lid, stock type	} Midget from (c)89501 (from approx. 1971)	1
56	322-645	\$0.49	BOLT, stay		2
57	324-590	\$0.19	WASHER, plain		4
58	312-000	\$0.24	NUT, nyloc		2
59	459-855	\$18.79	MOULDING, cockpit	} 1275, 1500	1
60	240-560	\$10.79	FINISHER, R/H		1
	240-565	\$10.79	FINISHER, L/H		1
61	226-660	\$1.39	STUD PLATE, moulding		9

62	324-990	\$0.29	WASHER, plain	} 1275, 1500	9
63	324-010	\$0.19	LOCKWASHER		9
64	310-040	\$0.19	NUT		9
70	244-730	\$349.99	LUGGAGE RACK, stainless steel, optional		1
71	314-295	\$2.99	SCREW, rack mounting		4
72	365-720	\$0.29	WASHER, plain		4
73	310-290	\$0.69	NUT, nyloc		4

## Master Lock Set

470-458	\$99.99	MASTER LOCK SET, 3 pieces (pictured at right)
470-448	\$66.99	LOCK SET, door (2 door locks with 2 keys)
470-435	\$34.99	LOCK, R/H door with 2 keys
470-440	\$34.99	LOCK, L/H door with 2 keys



## Door Lock Fitting Kit

Fits 1964-'80. Fit door locks without using the factory style securing clips, which are not easy to fit and very difficult to remove. These new clips are also designed to prevent the lock from rotating in the door skin.

402-195 \$13.29



\* Note: Parts marked "BMH" are produced by British Motor Heritage.

# Body Mouldings - Midget

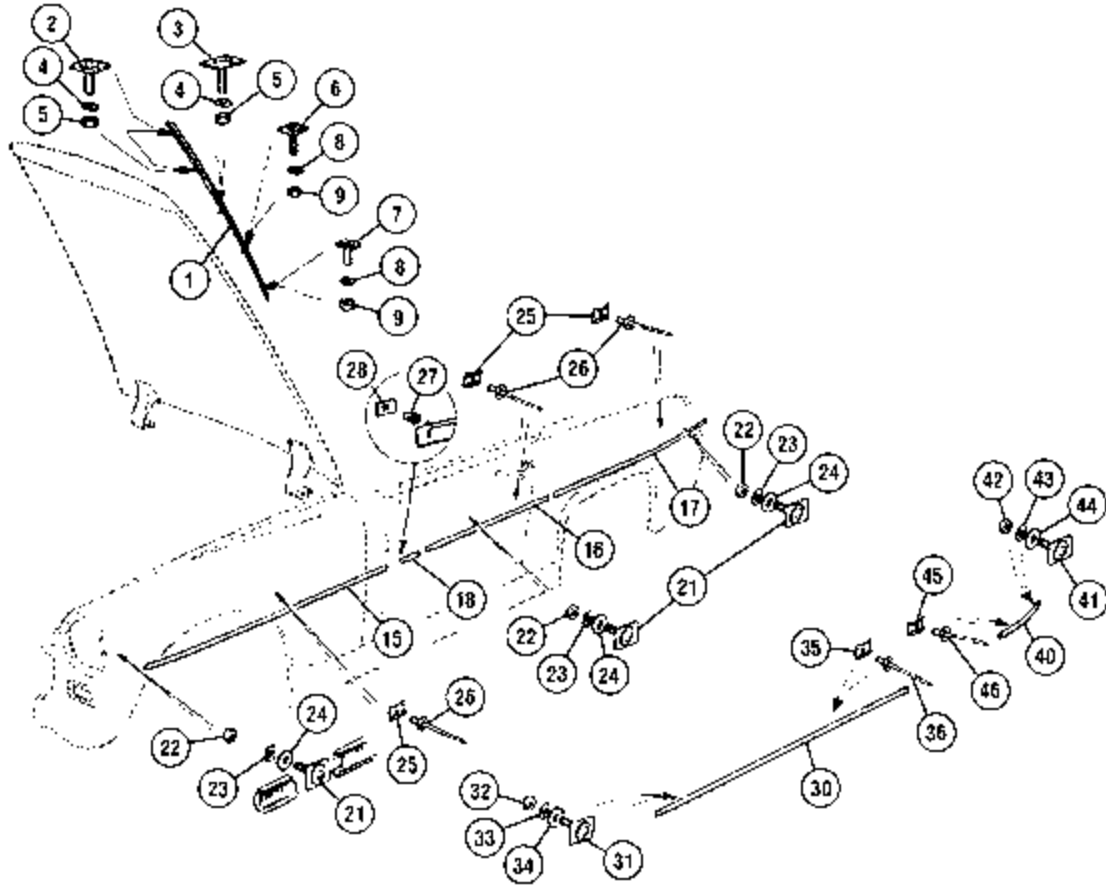

No.	Part No.	Price (each)	Description	Application	Qty. Req.	No.	Part No.	Price (each)	Description	Application	Qty. Req.
<b>Mouldings</b>											
1	459-610	\$147.89	MOULDING, hood	Midget to (c)66225 (‘61-approx. ‘68)	1	30	459-895	\$21.49	MOULDING, sill	Midget from (c)74886 (1970-on)	2
2	326-705	\$3.89	STUD PLATE, front two positions		2	31	326-618	\$18.99	FITTING KIT, sill mouldings		1
3	326-075	\$0.69	STUD PLATE, center position		1	32	326-077	\$1.89	STUD PLATE (front end of sill)		2
4	324-010	\$0.19	WASHER, locking, front three positions		3	32	310-040	\$0.19	NUT, stud plate to sill		2
5	310-040	\$0.19	NUT, front three positions		3	33	324-010	\$0.19	WASHER, locking		2
6	326-725	\$3.89	STUD PLATE, second rearmost position		1	34	315-085	\$0.14	WASHER, plain		2
7	326-735	\$3.39	STUD PLATE, rear position		1	35	326-610	\$0.59	CLIP, moulding to sill	14	
8	315-070	\$0.24	WASHER, locking, rear two positions		2	36	326-295	\$0.59	RIVET, clip to sill	14	
9	310-625	\$0.29	NUT, rear two positions		2						
15	459-868	NA	UPPER SIDE MOULDING SET	Midget to (c)74885 (1961-‘69)	1	40	459-890	\$17.49	MOULDING, rear wing, LH	Midget 1500	1
16	459-860	\$34.89	MOULDING, fender		2	41	459-885	\$17.49	MOULDING, rear wing, RH		1
17	459-875	\$31.99	MOULDING, door, LH		1	42	326-077	\$1.89	STUD PLATE (rear of fender)		2
18	459-870	\$31.99	MOULDING, door, RH		1	43	310-040	\$0.19	NUT, stud plate to fender		2
21	459-880	\$33.99	MOULDING, rear wing		2	44	324-010	\$0.19	WASHER, locking		2
22	459-865	\$18.89	MOULDING, ‘A’ post		2	45	315-085	\$0.14	WASHER, plain		2
23	326-608	\$49.99	FITTING KIT, upper side mouldings		1	46	326-610	\$0.59	CLIP, moulding to fender	6	
24	326-077	\$1.89	STUD PLATE		6	46	326-295	\$0.59	RIVET, clip to fender	6	
25	310-115	\$0.24	NUT, stud plate to fender & door		6						
26	324-010	\$0.19	WASHER, locking		6						
27	315-085	\$0.14	WASHER, plain	6							
28	326-610	\$0.59	CLIP	40							
29	326-295	\$0.59	RIVET, clip to fender & door	40							
30	326-665	\$0.29	CLIP, front moulding lug to ‘A’ post	2							
31	326-510	\$0.24	SPIRE NUT, rear lug to ‘A’ post	2							

# Plugs & Grommets

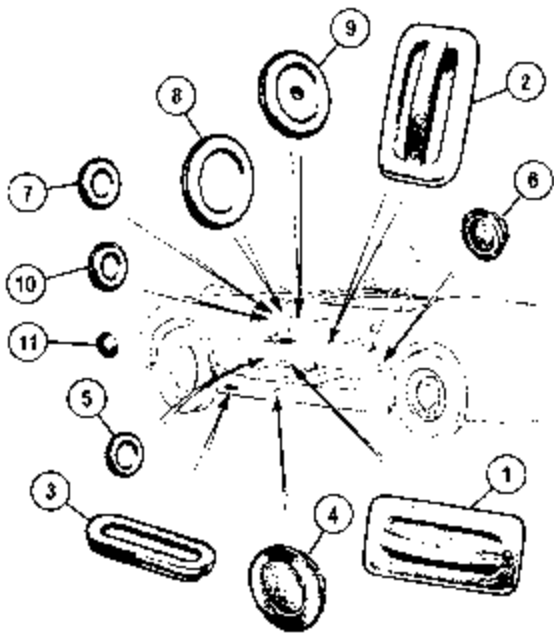

No.	Part No.	Price (each)	Description	Application	Qty. Req.
<b>Bugeye</b>					
1	680-940	\$1.89	PLUG, RH Toe Box Side	} Bugeye	1
2	680-940	\$1.89	PLUG, gearbox filler		1
3	282-235	\$1.99	PLUG, sill & sling point		A/R
4	282-135	\$1.89	PLUG, jack hole		2
5	282-960	\$1.39	PLUG, steering column blanking		1
6	282-150	\$2.19	PLUG, driveshaft inspection		1
7	682-075	\$0.89	PLUG, LH footwell		1
8	NA		PLUG, blanking		1
9	682-205	\$3.79	GROMMET, main wiring harness		1
10	240-515	\$1.39	GROMMET, wiper rack		1
11	282-140	\$1.29	PLUG, hinge holes (in door)		8

No.	Part No.	Price (each)	Description	Application	Qty. Req.
<b>Non-Bugeye</b>					
20	280-690	\$1.19	GROMMET, bumper bracket		2
21	282-135	\$1.89	PLUG, jacking point	qty. increased in 1975	2/4
22	280-105	\$3.99	GROMMET, fuel filler tube		1
23	282-385	\$1.19	GROMMET, no. plate lamp harnesses		2
24	282-960	\$1.39	PLUG, steering column hole	passenger's side	1
25	282-395	\$2.89	GROMMET, washer tube		1
	682-480	\$0.99	GROMMET, speedometer cable		1
	282-385	\$1.19	GROMMET, oil pressure pipe	} 1961-'77	1
	240-515	\$1.39	GROMMET, temp. gauge tube		1
26	282-385	\$1.19	GROMMET, heater/air cable	if heater is fitted	1
	282-925	\$0.69	PLUG, heater cable hole (5/8")	if heater not fitted	1
	282-385	\$1.19	GROMMET, choke cable through bulkhead		1
	240-515	\$1.39	GROMMET, wiper rack through bulkhead		1
	682-205	\$3.79	GROMMET, main harness in bulkhead		1
	682-480	\$0.99	GROMMET, wiper harness in bulkhead		1
	682-480	\$0.99	GROMMET, dip switch harness in footwell	1961-'69	1
27	282-975	\$0.99	GROMMET, oil cooler hole in mudshield		2
28	NA		PLUG, wheel arch panel		2
29	280-200	\$1.39	GROMMET, front lamp wires		3
	680-630	\$0.89	GROMMET, hood cable in ft. panel		1
	281-050	\$5.49	GROMMET, hood cable, toe board	1961-'78	1
30	282-150	\$2.19	PLUG, propshaft lubricating hole		1
31	282-235	\$1.99	PLUG, front floor pan		2
32	682-075	\$0.89	PLUG, LH footwell side	(if fitted)	2
33	NA		PLUG, slave cyl. access hole (Not available. Use #34 as replacement.)	} 1961-'76	1
34	680-940	\$1.89	PLUG, gearbox filler hole		1
35	NA		PLUG, demister outlet, footwell side	if heater not fitted	2
36	282-495	\$0.49	PLUG, 'top hat', footwell side		2
37	281-050	\$5.49	GROMMET, fuel pump breather	} 1961-'74	1
	565-050	\$0.79	GROMMET, fuel pump breather		1
	282-385	\$1.19	GROMMET, fuel tank sender harness		1

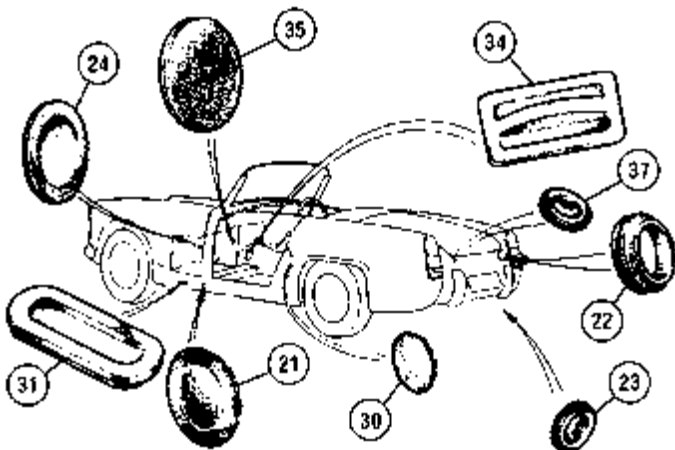
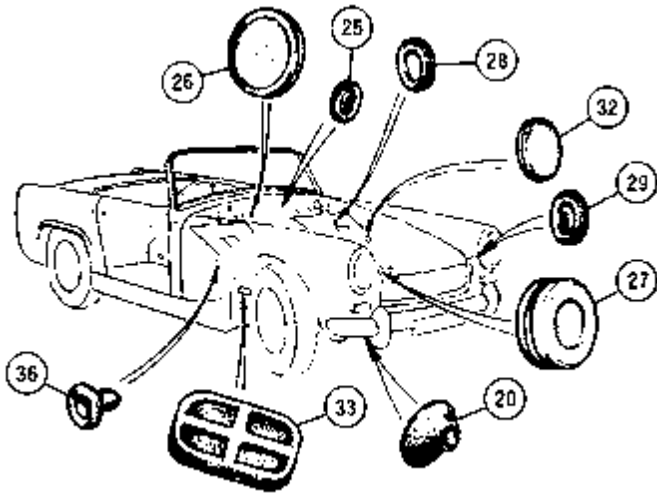

# Badges & Mirrors

For Bugeye badges, see pages 56-57

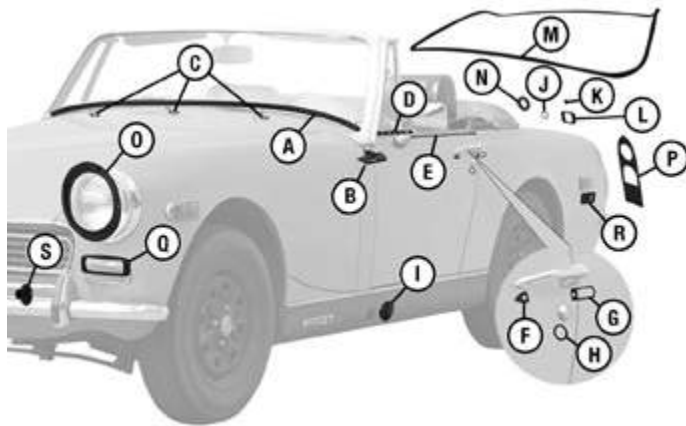
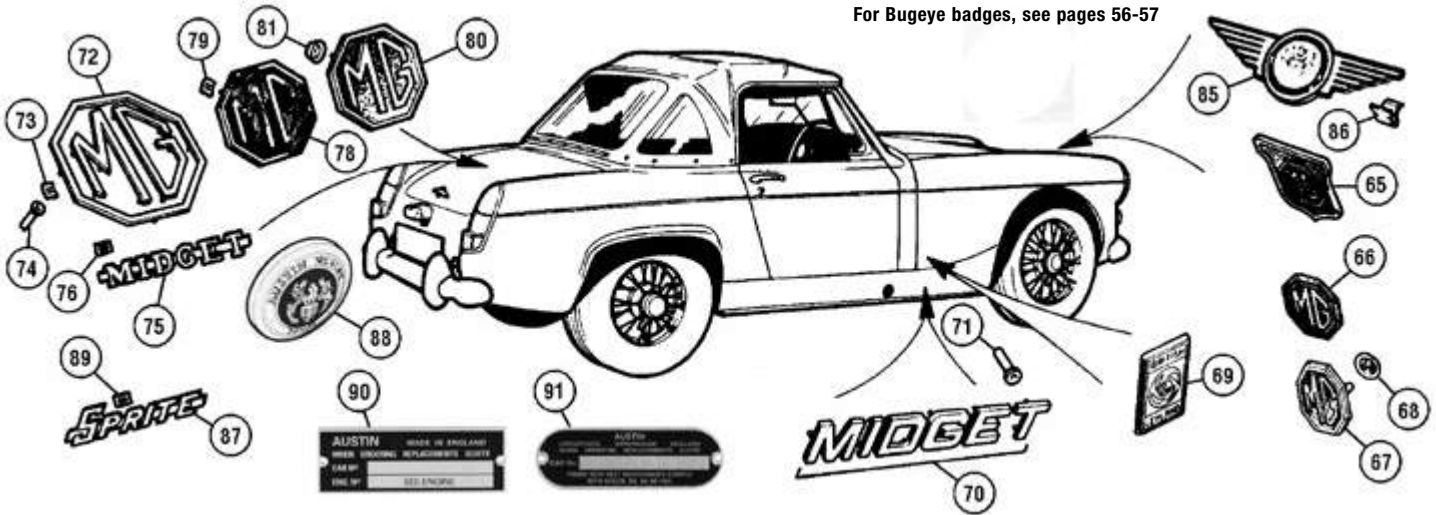

## Body Rubber Repaint Kits (not Bugeye)

It's no longer a chore to track down all the rubber bits and pieces commonly replaced during a repaint or moderate restoration. Start with the base kit, which contains the pieces common to all years, then add the supplemental kit specific to your year. That's all there is to it. See the accompanying tables for specific content.

### Base Rubber Kits:

Sidecurtain cars	282-834	\$36.99
Wind-up window cars	282-835	\$79.99
1961-69 Supplement	282-836	\$19.99
1970-74 Supplement	282-837	\$46.99
1975-80 Supplement	282-838	\$39.99

Illus.	Description	Qty.
A	Windshield Seal	1
B	Windshield Pillar Pad	2
C	Wiper Bezel Pad	2/3
D	Vent Window Seal	2
E	Door Top Seal	2
F	Door Handle Gasket, small	2
G	Door Handle Gasket, large	2
H	Door Lock Gasket	2
I	Jack Hole Plug	2
J	Trunk Lid Handle Gasket	1
K	License Plate Lamp Wire Grommet	2
L	Reverse Lamp Pad	2
M	Trunk Seal	1
N	Filler Neck Grommet	1
O	Headlamp Seals	2
P	Taillamp Gaskets	2
Q	Front Park Lamp Gaskets	2
R	Rear Sidelamp Base Rubber	2
S	Front Bumper Mount Grommets	2

### Body Rubber Kit Contents

Base Kit 282-834	A, B, C, I, J, K, M, N
Base Kit 282-835	A, B, C, D, E, F, G, H, I, J, K, L, M, N
1961-69 Supplement	O, P, Q, S
1970-74 Supplement	O, P, Q, R, S
1975-80 Supplement	I, O, P, R

LOCAL & OVERSEAS: 805-681-3400

FAX: 805-692-2525 www.mossmotors.com



No.	Part No.	Price (each)	Description	Application	Qty. Req.
-----	----------	--------------	-------------	-------------	-----------

### Midget Badges

65	201-050	\$15.49	GRILLE BADGE, 'MG'	1961-'69	1
66	201-060	\$11.49	GRILLE BADGE, 'MG'	1970-'74	1
67	475-165	\$19.99	BUMPER BADGE, 'MG'	1975-'80	1
68	326-530	\$0.24	CLIP, badge to bumper		2
69	470-687	\$5.89	BADGE, "British Leyland" (silver on blue, self-adhesive)	1970-'71	2
	470-686	\$9.99	BADGE, "British Leyland" (blue on silver, self-adhesive)	1972-on	2
70	470-605	\$16.79	SILL LETTER SET, 'Midget'	1970-on	2
71	326-650	\$0.49	CLIP		24
72	470-698	\$13.99	TRUNK BADGE SET, 'MG'	1961-'69	1
73	326-500	\$0.29	SPIRE NUT		13
74	326-650	\$0.49	CLIP, alternative		13
75	470-625	\$10.79	TRUNK BADGE, 'Midget'		1
76	326-510	\$0.24	SPIRE NUT		2
78	470-665	\$14.89	TRUNK BADGE, plastic, 'MG'	1970-1976 to (c)171430	1
79	326-530	\$0.24	SPIRE NUT		3
80	470-690	\$23.89	TRUNK BADGE, metal, 'MG'	1976 from 171431-on	1
81	326-530	\$0.24	CLIP		3

### Sprite Badges

85	031-600	\$25.99	HOOD BADGE, 'Austin Healey Sprite'		1
86	326-535	\$0.69	CLIP		4
87	470-615	\$24.89	TRUNK BADGE, 'Sprite'	Mk2	1
88	408-447	\$23.99	TRUNK BADGE, round	Mk3, 4	1
89	326-510	\$0.24	SPIRE NUT		2
90	408-920	\$5.89	CAR NUMBER PLATE	Sprite 948-1098	1
91	408-925	\$10.99	CAR NUMBER PLATE	Sprite 1275 thru 1969	1

### Fender Mirrors

165-400	\$19.49	FENDER MIRROR, R/H flat	1
165-500	\$19.49	FENDER MIRROR, L/H flat	1
165-210	\$22.99	FENDER MIRROR, R/H convex	1
165-300	\$22.99	FENDER MIRROR, L/H convex	1

### Door Mirrors

165-170*	\$49.99	DOOR MIRROR, R/H flat, stainless, TEX brand	1
165-135*	\$49.99	DOOR MIRROR, L/H flat, stainless, TEX brand	1
165-195*	\$46.99	DOOR MIRROR, R/H flat, black, TEX brand	1
165-190*	\$46.99	DOOR MIRROR, L/H flat, black, TEX brand	1
165-185**	\$74.99	DOOR MIRROR, R/H convex, stainless, TEX	1
165-180**	\$74.99	DOOR MIRROR, L/H convex, stainless, TEX	1
165-183	\$14.99	MIRROR GLASS only, flat	A/R
165-182	\$15.39	MIRROR GLASS only, convex	A/R
165-630	\$21.99	BASE KIT (chrome plinth), TEX brand	2
165-638	\$11.99	MOUNTING KIT (pad & screws), TEX brand	2

\* Base kit 165-630 must be used with these mirrors.

\*\* These mirrors include chrome base kit.

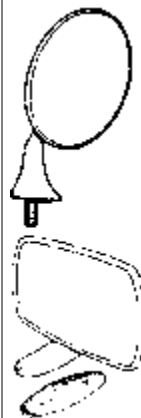

# Door Windows

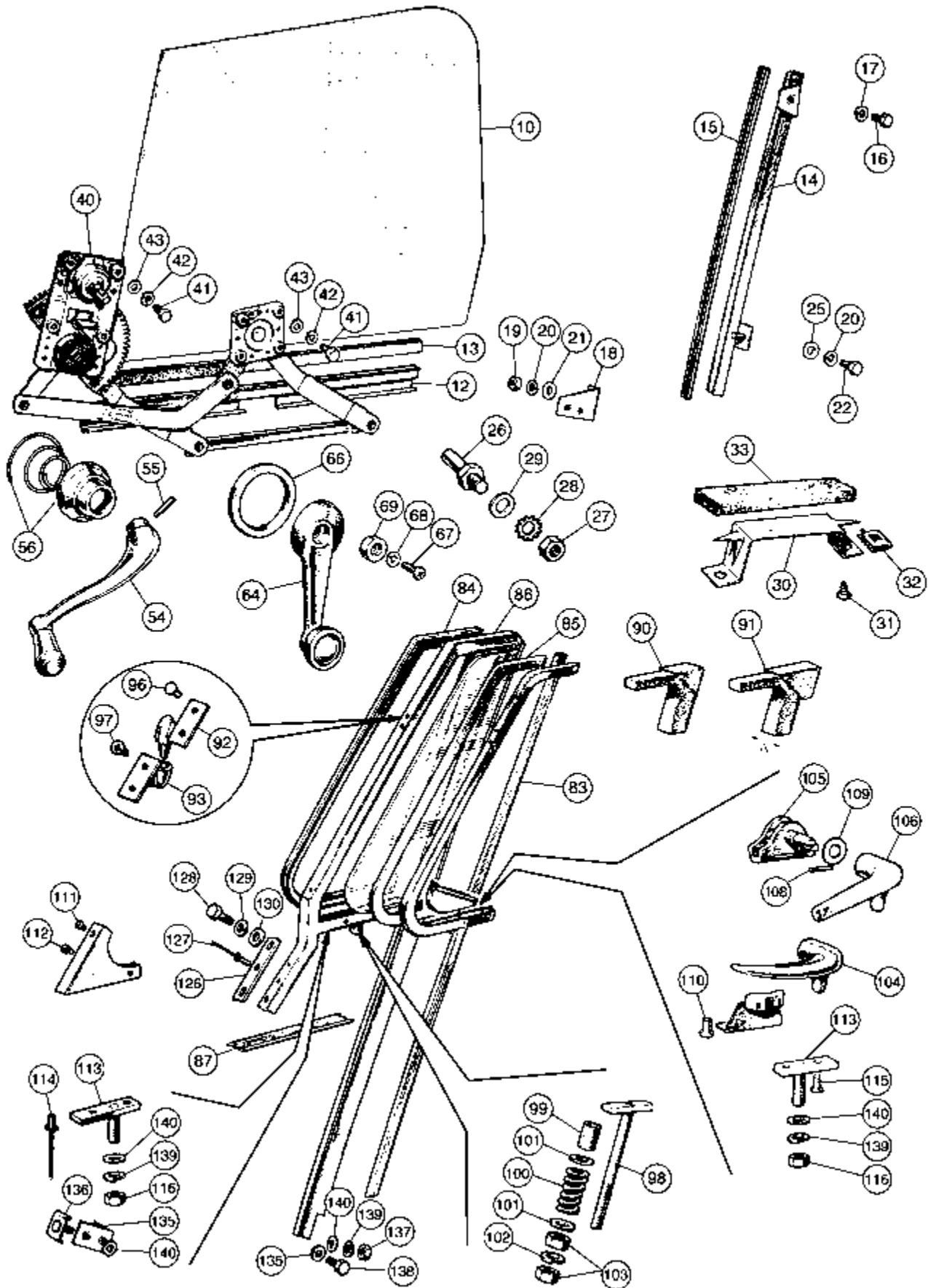

MOSS

MOSS MOTORS, LTD.  
TOLL-FREE ORDERS

1-800-667-7872



# Door Windows

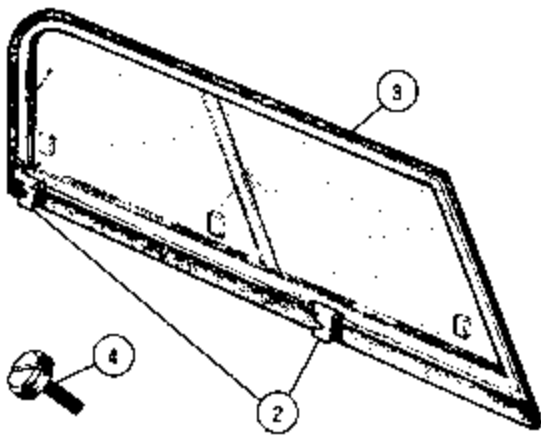

No.	Part No.	Price (each)	Description	Application	Qty. Req.
-----	----------	--------------	-------------	-------------	-----------

## Sidecurtains

	259-678	\$559.99	SIDECURTAIN SET, complete		1
2	259-675	\$34.99	BRACKET SET, with nuts & bolts		1
3	282-455	\$18.89	SEAL, L/H		1
	282-465	\$18.89	SEAL, R/H		1
4		NA	SCREW, sidecurtain retaining	Bugeye thru HAN5-1605	4
	401-690	\$5.79	SCREW, sidecurtain mounting	Bugeye from HAN5-1606 Sprite HAN6-101 thru 24731	4
	401-700	\$15.99	SCREW, sidecurtain mounting	Midget thru GAN1-16183 Sprite from HAN7-24732 Midget from GAN2-16184	4

Our U.K.- made aluminum sidecurtains are close reproductions of the original units fitted to all except the earliest Bugeyes, which used a primitive fabric covered design. Our sidecurtains fit all.

No.	Part No.	Price (each)	Description	Application	Qty. Req.
-----	----------	--------------	-------------	-------------	-----------

## Door Windows

10	459-920	\$99.99	DOOR GLASS, RH		1
	459-925	\$99.99	DOOR GLASS, LH		1
12	407-025	NA	CHANNEL, lower		2
13	680-667	\$2.99	GLAZING STRIP, sold per foot	Cut to 18 3/8" long.	A/R
14	407-014	\$34.99	CHANNEL, rear, RH		1
	407-019	\$34.99	CHANNEL, rear, LH		1
15	458-610	\$3.19	GLAZING STRIP, felt and rubber		2
16	322-170	\$0.49	SCREW, channel top to door		2
17	324-020	\$0.20	LOCKWASHER		2
18		NA	BRACKET, channel bottom to door, RH		1
		NA	BRACKET, channel bottom to door, LH		1
19	310-760	\$0.39	NUT, bracket to channel bottom		2
20	324-020	\$0.20	LOCKWASHER		6
21	324-590	\$0.19	WASHER, plain		2
22	322-170	\$0.49	SCREW, bracket to door		4
25	324-590	\$0.19	WASHER, plain		4
26		NA	STOP, regulator		2
27	310-140	\$0.24	NUT, stop to door		2
28	315-300	\$0.49	WASHER, shakeproof		2
29	365-720	\$0.29	WASHER, plain		2
30		NA	STOP, lower		2
31	323-705	\$0.29	SCREW, lower stop to door bottom		4
32		NA	SPIRE NUT		4
33	402-230	\$1.99	FELT PAD, lower stop		2
40	402-295	NA	REGULATOR, window, RH	Midget to (c)60459	1
	402-290	NA	REGULATOR, window, LH	Sprite to (c)72040	1
	405-535	NA	REGULATOR, window, RH	Midget (c)60460-on	1
	405-530	NA	REGULATOR, window, LH	Sprite (c)72041-on	1
41	322-170	\$0.49	SCREW, regulator to door		16
42	324-020	\$0.20	WASHER, locking		16
43	324-115	\$0.24	WASHER, plain		16
54	472-110	\$45.99	HANDLE, window regulator	Midget to (c)60459	2
55	803-230	\$1.49	PIN, handle to regulator	Sprite to (c)72040	2
56	470-600	\$14.49	ESCUTCHEON AND SPRING		2
64	472-520	\$2.29	HANDLE, window, black plastic	Midget (c)60460-on	2
	472-540	\$19.99	HANDLE, window, chrome (repl.)	Sprite (c)72041-on	2
66	472-515	\$2.89	ESCUTCHEON, handle		2

No.	Part No.	Price (each)	Description	Application	Qty. Req.
67	472-535	\$0.59	SCREW, chrome	} to 1974 approx.	2
68	324-010	\$0.19	LOCKWASHER		2
69	472-530	\$3.79	ESCUTCHEON, chrome		2
70	472-495	\$1.89	SCREW, flanged, handle to regulator	1974 on approx.	2
80	*	NA	QUARTER LIGHT ASS'Y, RH, chrome (with hooked handle)	} to G-AN4-64474; to H-AN9-75702.	1
	*	NA	QUARTER LIGHT ASS'Y, LH, chrome (with hooked handle)		1
	*	NA	QUARTER LIGHT ASS'Y, RH, chrome (with straight handle)	} G-AN4-64475 on; to G-AN5-121649; H-AN9-75703 on;	1
	*	NA	QUARTER LIGHT ASS'Y, LH, chrome (with straight handle)		1
*These early assemblies are no longer available. The later type below may be used.					
82	407-030	\$449.99	QUARTER LIGHT ASS'Y, RH, stainless steel (w/straight handle)	} Midget from (c)121650 (1973-'80)	1
	407-040	\$449.99	QUARTER LIGHT ASS'Y, LH, stainless steel (w/straight handle)		1
83	458-610	\$3.19	GLAZING STRIP, felt and rubber		2
84	282-075	\$11.99	SEAL, quarter light, RH		1
	282-085	\$11.99	SEAL, quarter light, LH		1
85	282-550	\$4.29	GLAZING RUBBER	Cut to 19" long.	2
86	459-930	\$99.99	GLASS, RH		1
	459-935	\$99.99	GLASS, LH		1
87	282-200	\$2.49	SEAL, quarter light to door, RH		1
	282-205	\$2.49	SEAL, quarter light to door, LH		1
90	282-575†	\$4.99	CORNER BLOCK	chrome ass'y. (1962-68)	2
91	282-595†	\$3.19	CORNER BLOCK A=7/16"	chrome ass'y. (1969-'72)	2
	282-065	\$1.99	CORNER BLOCK A=1/2"	stainless ass'y. (1973-'80)	2
†These two corner blocks may be interchanged.					
92		NA	TOP PIVOT, upper half, RH	} chrome ass'y.	1
93		NA	TOP PIVOT, lower half, RH		1
		NA	TOP PIVOT, upper half, LH		1
		NA	TOP PIVOT, lower half, LH		1
	407-045	\$5.99	TOP PIVOT, upper half, RH	} stainless ass'y.	1
	407-050	\$5.99	TOP PIVOT, lower half, RH		1
	407-055	\$5.99	TOP PIVOT, upper half, LH		1
	407-060	\$5.99	TOP PIVOT, lower half, LH		1
96	325-085	\$1.79	RIVET, upper pivot half to frame		4
97	314-305	\$1.09	SCREW, lower pivot half to frame		4
98	407-130	NA	BOTTOM PIVOT	chrome ass'y. (use 407-140)	2
	407-140	\$18.79	BOTTOM PIVOT	stainless ass'y.	2
99		NA	DISTANCE TUBE, bottom pivot		2
100	329-850	\$1.49	SPRING, bottom pivot		2
101	324-590	\$0.19	WASHER, plain		4
102	324-020	\$0.20	WASHER, locking		2
103	310-760	\$0.39	NUT		4
104	470-505	NA	LOCKING HANDLE, hooked, RH	} Midget to (c)64474 Sprite to (c)75702	1
	470-515	NA	LOCKING HANDLE, hooked, LH		1
105	470-425	NA	BRACKET AND PIVOT		2
	470-430	NA	BRACKET AND PIVOT	} G-AN4-64475 on H-AN9-75703 on	2
106	470-585	\$26.99	LOCKING HANDLE, straight, RH		1
	470-595	\$26.99	LOCKING HANDLE, straight, LH		1
108	325-470	\$2.79	PIN, handle to pivot		2
109	324-295	\$0.29	WASHER, waded		2
110	325-085	\$1.79	RIVET, bracket to inner frame		4
111	314-300	\$0.59	SCREW, corner finisher to frame, upper		2
112	458-550	\$0.79	SCREW, corner finisher to frame, lower		4
113	407-065	NA	STUD PLATE, quarter light to door		4
114		NA	RIVET, front stud plate to frame		4
115		NA	RIVET, rear stud plate and latch to frame		4
116	312-010	\$2.49	NUT, stud plate to door		4
126		NA	SHIM, front frame foot to door, 1/16" thick		A/R
127		NA	RIVET, shim to front frame foot		2
128	322-540	\$0.69	SCREW, front frame foot to door		4
129	365-730	\$0.25	WASHER, locking		4
130		NA	WASHER, plain		4
135		NA	BRACKET, drop glass channel to door		2
136	407-075	\$0.99	STUD PLATE, bracket to drop glass channel		2
137	310-760	\$0.39	NUT, bracket to drop glass channel		2
138	322-170	\$0.49	BOLT, bracket to door		4
139	324-020	\$0.20	WASHER, locking		10
140	324-590	\$0.19	WASHER, plain		10

**LOCAL & OVERSEAS: 805-681-3400**  
**FAX: 805-692-2525** [www.mossmotors.com](http://www.mossmotors.com)



# Bumpers

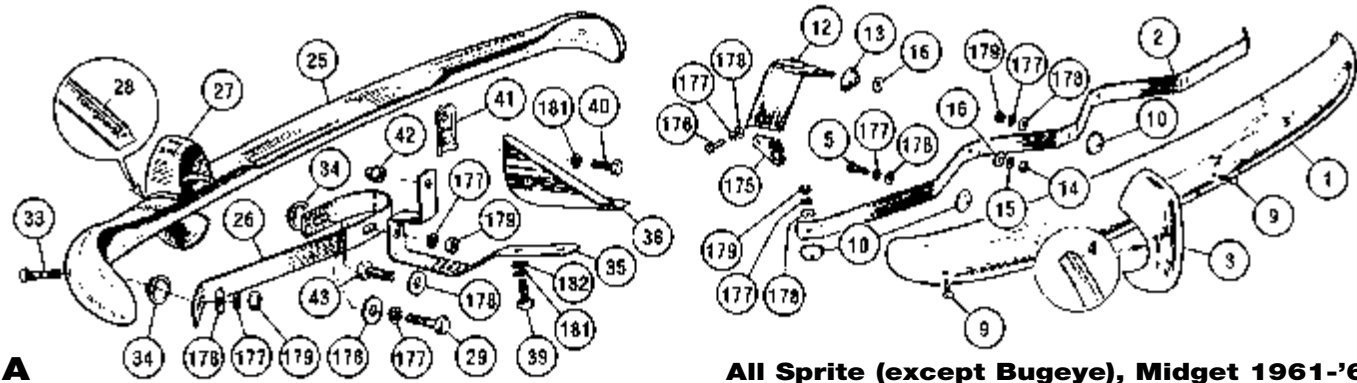

**A**

**All Sprite (except Bugeye), Midget 1961-'69**

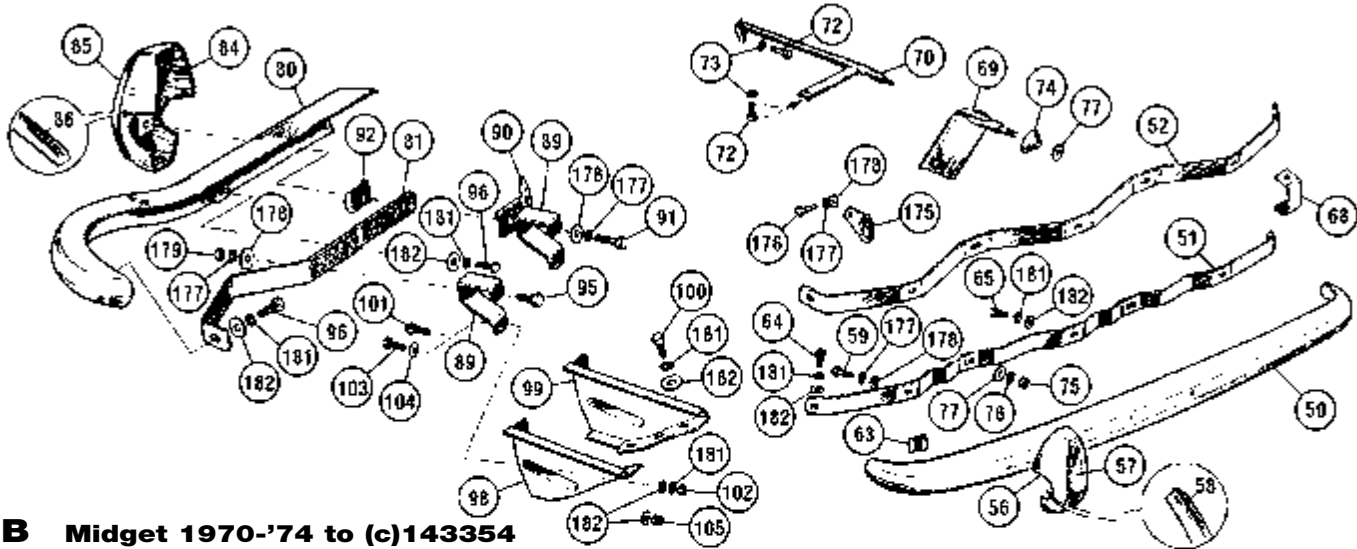

**B Midget 1970-'74 to (c)143354**

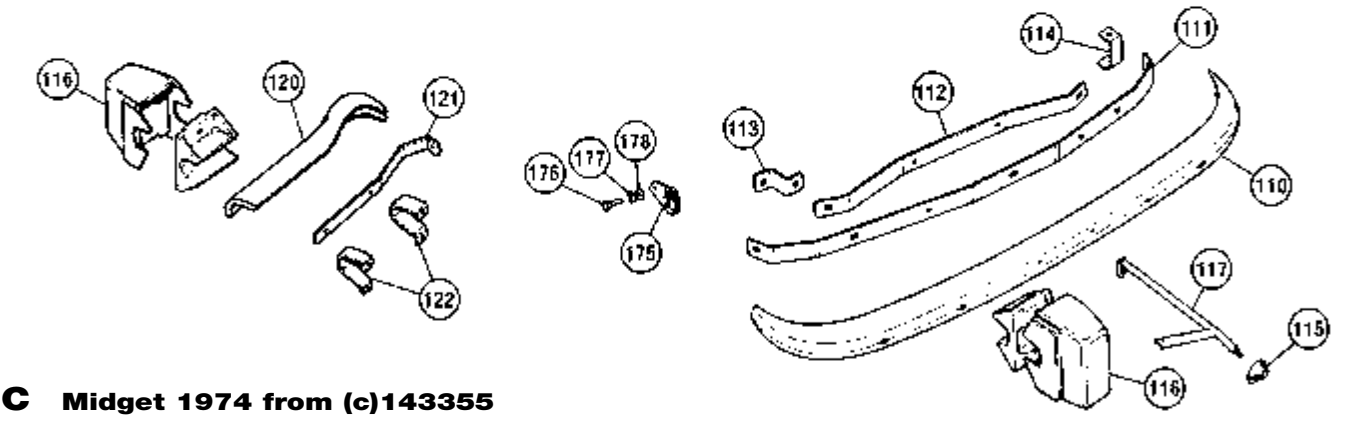

**C Midget 1974 from (c)143355**

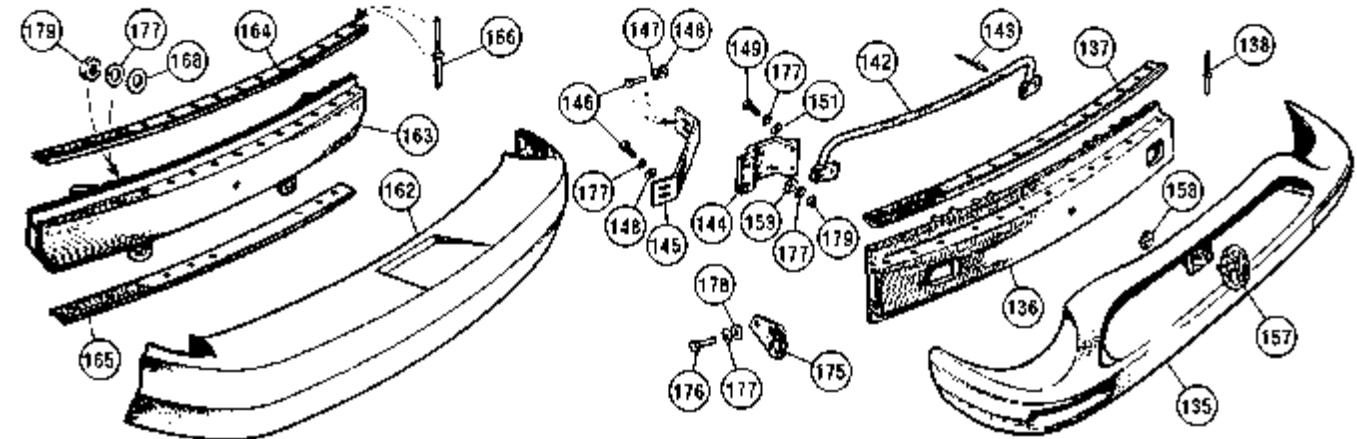

**D Midget 1500 1975-'80**

**MOSS** MOSS MOTORS, LTD. TOLL-FREE ORDERS **1-800-667-7872**

No.	Part No.	Price (each)	Description	Application	Qty. Req.
-----	----------	--------------	-------------	-------------	-----------

**A - 948 (except Bugeye), 1098, 1275 to Sprite (c)85286, Midget (c)74885 (1961-'69)**

1	400-240	\$234.99	BUMPER BLADE, front		1
2	400-250	\$69.99	SPRING BAR		1
3	853-110	\$58.99	OVER RIDER		2
4	400-418	\$3.69	PACKING STRIP SET, for 4 over riders		1
5	322-615	\$2.69	BOLT, over rider and blade to spring bar		2
9	322-900	\$1.89	BOLT & NUT, bumper mounting, chrome		3
10	400-315	\$0.89	PACKING PIECE, spring bar to blade		5
12	455-905	\$29.99	BRACKET, bumper to chassis, RH		1
	455-855	\$29.99	BRACKET, bumper to chassis, LH		1
13	280-690	\$1.19	GROMMET, front valance		2
14	472-347	\$0.24	NUT, spring bar to bracket		2
15	322-835	\$0.39	WASHER, locking		2
16	315-120	\$0.89	WASHER, plain		4
25	853-100	\$309.99	BUMPER BAR, rear		1
26	400-260	\$10.79	SPRING BAR		2
27	853-110	\$58.99	OVER RIDER		2
28	400-418	\$3.69	PACKING STRIP SET, for 4 over riders		1
29	322-615	\$2.69	BOLT, over rider and blade to spring bar		2
33	322-900	\$1.89	BOLT & NUT, bumper mounting, chrome		2
34	400-315	\$0.89	PACKING PIECE, spring bar to blade		4
35	400-505	\$17.69	BRACKET, bumper mounting, RH		1
	400-515	\$17.69	BRACKET, bumper mounting, LH		1
38	400-545	\$26.99	SUPPORT, mounting bracket (BMH*)		2
39	322-040	\$0.49	BOLT, bracket/support to boot floor		4
40	322-040	\$0.49	BOLT, bracket/support to rear valance		2
41	400-525	\$21.79	FINISHER, chrome, mounting bracket		2
42	402-550	\$3.09	DOME NUT, chrome		2
43	320-285	\$0.69	BOLT, spring bar to bracket		2

**B - 1275 Midget from (c)74886 to 143354 (1970-mid'74)**

50	400-270	\$289.99	BUMPER BLADE, front		1
51	NA		SPRING BAR (Not avail.-use #52) thru 1972		1
52	400-290	\$69.99	SPRING BAR	1973-'74 to (c)143354	1
56	400-310	\$52.99	OVER RIDER		2
57	400-550	\$8.99	RUBBER FACING, over rider		2
58	400-418	\$3.69	PACKING STRIP SET, for 4 over riders		1
59	320-345	\$0.79	BOLT, over rider and blade to spring bar		2
63	400-585	\$1.79	SPACER, bumper blade to spring bar		2
64	322-040	\$0.49	BOLT, outer ends of spring bar to blade		2
65	322-540	\$0.69	BOLT center of spring bar to blade		1
68	400-535	NA	REINFORCEMENT	from (c)123731 (1973+)	2
69	455-905	\$29.99	BRACKET, bumper to chassis, RH	} to (c)138000 (1970-'73)	1
	455-855	\$29.99	BRACKET, bumper to chassis, LH		1
70	400-580	NA	BRACKET, bumper to chassis, RH	} from (c)138801 (1974)	1
	400-590	NA	BRACKET, bumper to chassis, LH		1
72	322-645	\$0.49	BOLT, bracket		4
73	324-020	\$0.20	WASHER, locking		4
74	280-690	\$1.19	GROMMET, front valance		2
75	472-347	\$0.24	NUT, spring bar to bracket		2
76	322-835	\$0.39	WASHER, locking		2
77	315-120	\$0.89	WASHER, plain		4
80	400-320	\$124.99	BUMPER BAR, rear, RH		1
	400-330	\$124.99	BUMPER BAR, rear, LH		1
81	400-340	\$9.79	SPRING BAR		2
84	400-310	\$52.99	OVER RIDER		2
85	400-550	\$8.99	RUBBER FACING, over rider		2
86	400-418	\$3.69	PACKING STRIP SET, for 4 over riders		1
89	400-350	\$9.99	BRACKET, bumper mounting		4
90	400-555	\$59.79	BRACKET, number plate lamp mounting, RH		1
	400-565	\$59.79	BRACKET, number plate lamp mounting, LH		1
91	320-345	\$0.79	BOLT, over rider to mounting bracket		2
92	400-585	\$1.79	SPACER, bumper blade to spring bar		2
95	322-050	\$0.49	BOLT, spring bar to mounting bracket		2
96	322-040	\$0.49	BOLT, bumper blade to spring bar		4
98	400-600	\$13.99	SUPPORT, mounting bracket, outer RH (BMH*)		1
99	400-605	\$21.99	SUPPORT, mounting bracket, inner RH (BMH*)		1
	400-610	\$13.99	SUPPORT, mounting bracket, outer LH (BMH*)		1
	400-615	\$21.99	SUPPORT, mounting bracket, inner LH (BMH*)		1
100	322-040	\$0.49	BOLT, support to trunk floor		12
101	321-708	\$4.99	BOLT & NUT, mounting bracket	} to (c)138800 (1970-'73)	8
102	310-140	\$0.24	NUT		8

\* Parts market "BMH" are produced by British Motor Heritage.

**LOCAL & OVERSEAS: 805-681-3400**  
**FAX: 805-692-2525** [www.mossmotors.com](http://www.mossmotors.com)



# Bumpers

No.	Part No.	Price (each)	Description	Application	Qty. Req.
-----	----------	--------------	-------------	-------------	-----------

103	322-290	\$0.89	BOLT, mounting bracket	from (c)138800	8
104	365-720	\$0.29	WASHER, plain	(1974)	16
105	310-290	\$0.69	NUT, nyloc		8

**C - 1275 Midget from (c)143355 to 154100 (mid 1974)**

NOTE: Hardware for this application is the same as under illustration B.

110	400-370	NA	FACE BAR, front bumper (may use earlier bumper 400-270)		1
111	400-380	NA	SPRING BRACKET		1
112	400-390	NA	SUPPORT		1
113	400-400	NA	BRACKET		2
114	400-535	NA	REINFORCEMENT		2
115	280-690	\$1.19	GROMMET, front bumper		2
116	400-410	NA	OVERRIDER, R/H, front & rear		2
	400-420	NA	OVERRIDER, L/H, front & rear		2
117	400-580	NA	BRACKET, bumper to chassis, R/H		1
	400-590	NA	BRACKET, bumper to chassis, L/H		1
120	400-430	NA	BUMPER, L/H rear		1
	400-440	NA	BUMPER, R/H rear		1
121	400-450	NA	SPRING BRACKET		2
122	400-460	NA	BRACKET		2

**D - Midget 1500 (1975-'80)**

135	400-470	NA	BUMPER MOULDING, front		1
136	400-480	NA	ARMATURE, bumper		1
137	400-500	NA	RETAINER, moulding to armature		2
138	326-195	NA	RIVET		26
142	400-490	\$39.99	SUPPORT, upper moulding		1
143	NA		RIVET		4
144	NA		SPRING BRACKET, inner, RH		1
	NA		SPRING BRACKET, inner, LH		1
145	400-570	\$15.49	SPRING BRACKET, outer		2
146	NA		SCREW, outer bracket to body and armature		8
147	324-040	\$0.29	WASHER, locking		8
148	475-155	NA	WASHER, plain		8
149	NA		SCREW, inner spring bracket to armature		8
150	324-040	\$0.29	WASHER, locking		8
151	475-155	NA	WASHER, plain		8
152	324-040	\$0.29	WASHER, locking		4
153	475-155	NA	WASHER, plain		4
157	475-170	\$27.99	BADGE, 'MG', gold on black	some 1975 cars.	1
	475-165	\$19.99	BADGE, 'MG', silver on black	from (c)171431	1
	475-175	\$39.99	BADGE, 'MG', silver on bright red	alternative.	1
158	326-530	\$0.24	CLIP, push fix, badge to bumper		2
162	400-510	NA	BUMPER MOULDING, rear		1
163	400-520	\$97.00	ARMATURE, bumper		1
164	400-530	NA	RETAINER, moulding to armature, upper		1
165	400-540	NA	RETAINER, moulding to armature, lower		1
166	326-195	NA	RIVET		28
167	324-040	\$0.29	WASHER, locking		4
168	475-155	NA	WASHER, plain		4

**Towing Eye / Common Hardware**

175	400-575	\$17.89	TOWING EYE	all	2
176	320-285	\$0.69	BOLT, towing eye		4
177	324-040	\$0.29	LOCKWASHER		A/R
178	324-860	\$0.19	WASHER, plain		A/R
179	310-050	\$0.59	NUT		A/R
181	365-730	\$0.25	LOCKWASHER		A/R
182	365-720	\$0.29	WASHER, plain		A/R

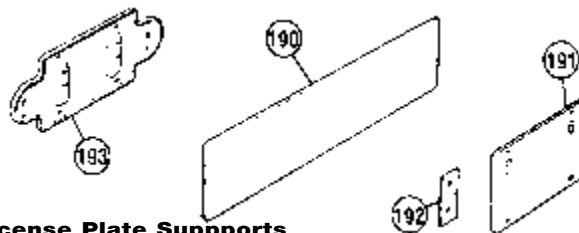

**License Plate Supports**

190	451-720	\$11.29	SUPPORT, license plate, British style		2
191	451-285	\$9.89	SUPPORT, license plate, for U.S. plates	} 948-1275 ft. & rear 1500 front	2
					1
192	402-560	\$3.69	BRACKET for front support	(all)	2
193	451-295	\$33.99	SUPPORT, license plate, rear, stock	} 1500	1
	451-296	\$43.99	SUPPORT, license plate, rear, stainless steel		1

# Door Fittings

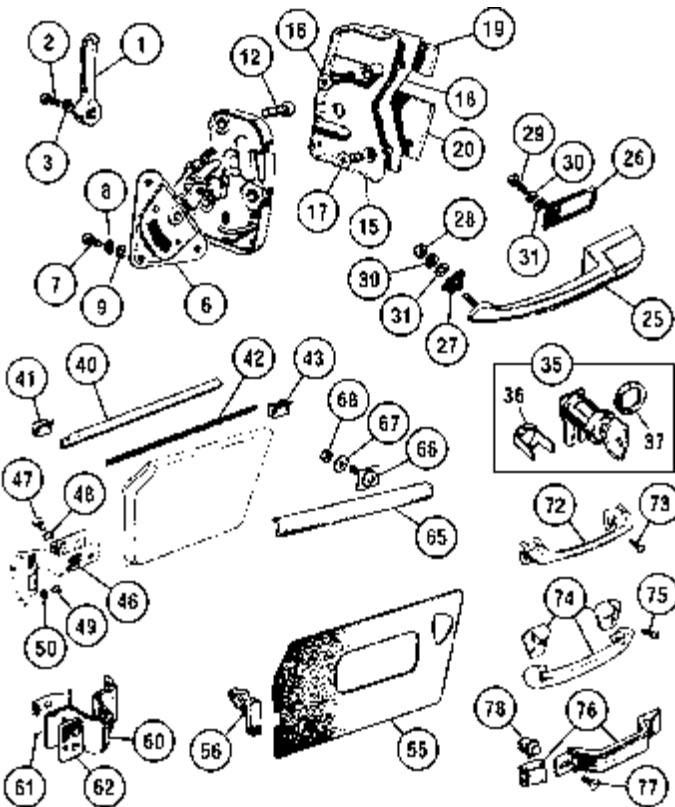
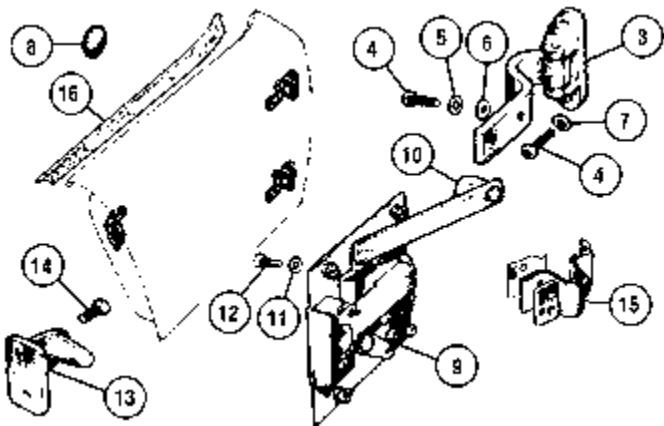

No.	Part No.	Price (each)	Description	Application	Qty. Req.
-----	----------	--------------	-------------	-------------	-----------

## Early Doors, 1958-'63

3	471-135	\$139.99	HINGE (British Motor Heritage part)		4
4	322-495	\$0.49	SCREW		20
5	315-300	\$0.49	WASHER, shakeproof		8
6	324-590	\$0.19	FLAT WASHER		8
7	462-385	\$0.19	LOCK WASHER		12
8	282-140	\$1.29	PLUG, rubber	948cc cars only	8
9	402-640	\$36.99	LATCH, R/H		1
9A	402-650	\$36.99	LATCH, L/H		1
10	402-670	\$12.89	KNOB		2
11	324-110	\$0.29	SPRING WASHER		8
12	323-005	\$0.39	SCREW		8
13	470-540	\$8.69	STRIKER		2
14	323-255	\$0.69	SCREW		4
15			CHECK STRAP	(see #60-62 below)	2
16	459-943	\$74.99	DOOR CAPPING, R/H		1
	459-942	\$74.99	DOOR CAPPING, L/H		1

19	402-340	\$3.89	TAPPED PLATE, upper (in 'B' post)		2
20	402-420	\$4.79	TAPPED PLATE, lower (in 'B' post)		2
25		NA	EXTERIOR HANDLE ASS'Y	1964-'67	2
	402-660	\$82.99	EXTERIOR HANDLE ASS'Y	1968-on	2
26	401-550	\$0.49	GASKET, handle to door, rear		2
27	401-540	\$0.39	GASKET, handle to door, front		2
28	310-040	\$0.19	NUT, handle to door		2
29	466-385	\$0.39	SCREW, handle to door		2
30	324-010	\$0.19	WASHER, locking		4
31	324-990	\$0.29	WASHER, plain		4
	470-458	\$99.99	MASTER LOCK SET., 3 pieces		1
			Includes 2 door locks, trunk handle & lock; keyed alike, with 2 keys		
	470-448	\$66.99	LOCK SET, door		1
			Includes 2 door locks; keyed alike, with 2 keys		
35	470-435	\$34.99	LOCK, R/H door with 2 keys		1
	470-440	\$34.99	LOCK, L/H door with 2 keys		1
36	401-590	NA	CLIP, lock retaining		2
37	402-170	\$0.69	GASKET, lock to door		2
40	282-175	\$8.89	WEATHER STRIP, door, outer, LH		1
	282-170	\$8.89	WEATHER STRIP, door, outer, RH		1
41	803-400	\$0.17	CLIP, outer weather strip to door		12
42	282-185	\$7.39	WEATHER STRIP, door, inner, LH		1
	282-180	\$7.39	WEATHER STRIP, door, inner, RH		1
43	317-065	\$0.99	CLIP, inner weather strip to door		12
46	471-140	\$129.99	HINGE, door (British Motor Heritage part)		4
47	322-880	\$0.49	SCREW, hinge to door		8
48	315-300	\$0.49	WASHER, shakeproof		8
49	322-495	\$0.49	SCREW, hinge to 'A' post		12
50	462-385	\$0.19	WASHER, shakeproof		12
55			DOOR PANEL, see page 78.		
56	803-420	\$0.79	CLIP, door panel (replacement)		18
60	240-670	\$22.99	CHECK STRAP, red	} all, including Bugeye	2
	240-675	\$22.99	CHECK STRAP, black		2
	240-680	\$22.99	CHECK STRAP, blue		2
	240-672	\$22.99	CHECK STRAP, green		2
	240-685	\$22.99	CHECK STRAP, navy		2
	240-690	\$22.99	CHECK STRAP, autumn leaf		2
	240-805	\$3.99	BRACKET, check strap		2
62	240-815	\$1.99	RETAINER, check strap	2	
65	402-700	NA	MOULDING, door top, untrimmed, RH		1
	402-705	NA	MOULDING, door top, untrimmed, LH		1
66	326-075	\$0.69	STUD PLATE, moulding to door top		4
67	315-085	\$0.14	WASHER, plain		4
68	159-340	\$0.49	NUT		4

No.	Part No.	Price (each)	Description	Application	Qty. Req.
-----	----------	--------------	-------------	-------------	-----------

## Late Doors, 1964-'80

1	402-685	\$19.99	HANDLE, remote control	} Midget to (c)60459*	2
2	323-205	\$1.49	SCREW, handle to remote control		} Sprite to (c)72040*
	402-690	NA	HANDLE, remote control (Use early handle & screw)	} Midget from (c)60460†	2
	323-005	\$0.39	SCREW, handle to remote control		} Sprite from (c)72041†
3	324-010	\$0.19	LOCKWASHER		2
6	402-675	NA	REMOTE CONTROL, latch, LH		1
	402-680	NA	REMOTE CONTROL, latch, RH		1
7	323-005	\$0.39	SCREW, remote control to door		6
8	324-010	\$0.19	WASHER, locking		6
9	315-085	\$0.14	WASHER, plain		6
12	323-585	\$0.49	SCREW, latch to door		6
15	401-340	NA	STRIKER PLATE, RH	} Midget to (c)60459*	1
	401-320	NA	STRIKER PLATE, LH		} Sprite to (c)72040*
	401-370	\$29.29	STRIKER PLATE, RH	} Midget from (c)60460†	1
	401-360	\$29.29	STRIKER PLATE, LH	} Sprite from (c)72041†	1

16	323-195	\$0.99	SCREW, long, striker plate to 'B' post		2
17	323-280	\$0.49	SCREW, short, striker plate to 'B' post		4
18	402-410	\$1.19	SHIM, striker plate to 'B' post, 0.064"	A/R	
	402-415	\$1.19	SHIM, striker plate to 'B' post, 0.032"	A/R	

\* thru 1967 † from 1968



**MOSS MOTORS, LTD.**  
TOLL-FREE ORDERS **1-800-667-7872**

# Wipers & Washers

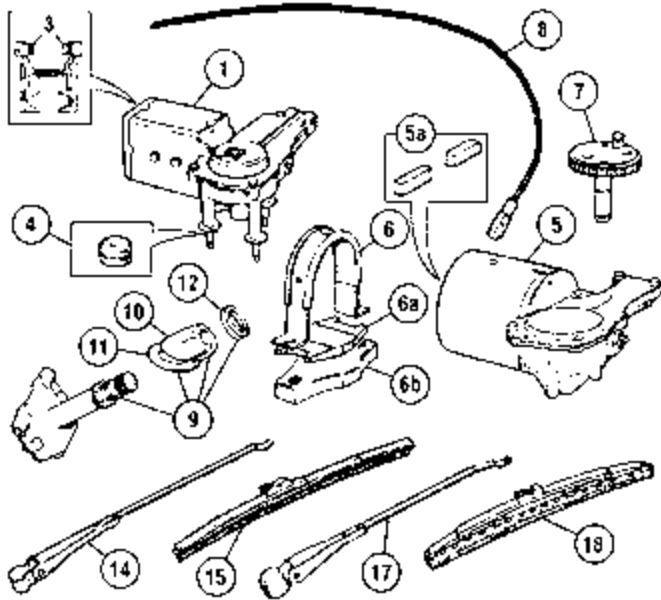

No.	Part No.	Price (each)	Description	Application	Qty. Req.
17	164-625	NA	WIPER ARM	1968	2
	164-610	\$27.99	WIPER ARM, TEX brand	1969 - '72	2/3
	164-615	\$32.49	WIPER ARM (stainless), TEX brand	1973-'76	3
	164-635	\$26.79	WIPER ARM (black), TEX brand	1977-'80	3
18	165-075	NA	WIPER BLADE	1968	2
	165-055	\$11.49	WIPER BLADE	1969 - '72	2/3
	165-046	\$11.49	WIPER BLADE (stainless)	1973-'76	3
	165-047	\$19.99	WIPER BLADE (black), TEX brand	1977-'80	3
	165-045	\$11.99	WIPER BLADE (black)		3

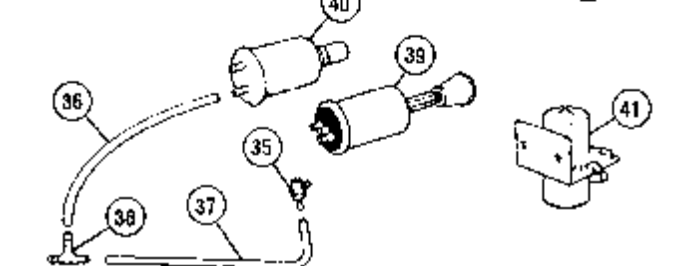
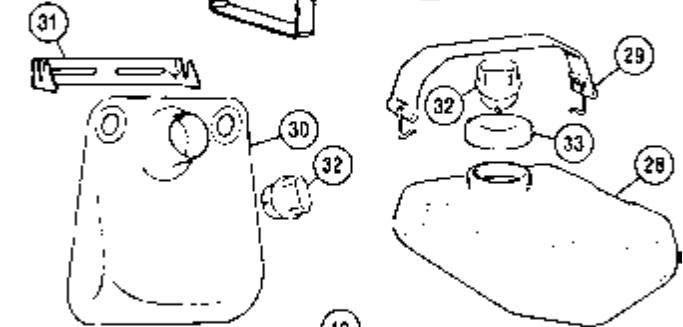
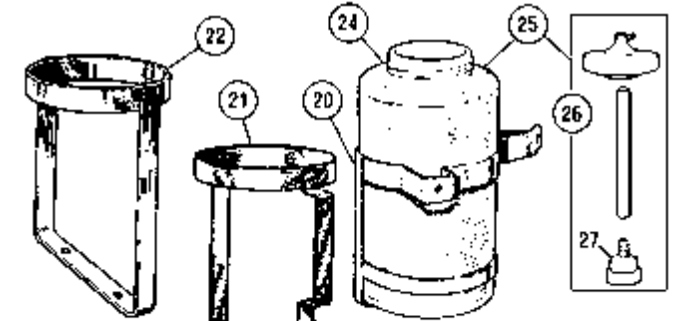

## Windshield Washer

20	361-215	\$44.99	BRACKET, washer bottle	Sprite Mkl,II, Midget Mkl	1	
21	361-245	\$11.29	BRACKET, washer bottle	from above thru 1967	1	
22	361-275	\$14.49	BRACKET, washer bottle	1968-'74	1	
24	361-125	\$47.99	CONTAINER (use with #20, 26, 27)	Sprite Mkl,II, Midget Mkl	1	
25	361-148	\$9.49	CONTAINER ASS'Y., complete	1098 from '64 & 1275	1	
26	361-140	\$7.49	CAP, with tube (included with #25)		1	
27	361-145	\$2.99	FOOT VALVE (included with #25 & 26)		1	
28	161-125	NA	CONTAINER	} 1500 to (c)166300	1	
29	361-135	NA	STRAP		1	
30	361-120	\$18.79	CONTAINER, bag	} 1500 from (c)166301	1	
31	361-270	\$12.89	BRACKET for bag		1	
32	361-190	\$1.19	FILLER PLUG	all 1500	1	
33	361-150	\$3.79	CAP	1500 to (c)166300	1	
35	361-240	\$4.79	JET, chromed	thru 1976	2	
	361-260	\$3.79	JET, black	from 1977	2	
36	361-210	\$0.89	TUBING, container to pump & pump to 3-way connector	} sold per foot	A/R	
37	361-210	\$0.89	TUBING, connector to jets		thru 1976	A/R
	361-220	\$0.89	TUBING, connector to jets		1977-on	A/R
38	361-235	NA	CONNECTOR, 3-way	thru 1976	1	
	115-372	\$1.19	CONNECTOR, 3-way	1977-on	1	
39	361-185	NA	PUMP, w/knob	948	1	
40	361-160	\$28.99	PUMP, manual (replacement)	1098	1	
			(Must use non-return valve 361-200 below in pump outlet line)			
	361-200	\$4.89	VALVE, in-line	use with pump 361-160	1	
41	361-180	\$8.89	PUMP, electric	1275 & 1500	1	

No.	Part No.	Price (each)	Description	Application	Qty. Req.
<b>Sprite Mkl-II, Midget Mkl</b>					
1	145-510	NA	WIPER MOTOR, less gear #7	{ replaces original units #75213 & 75387	1
3	554-035	\$19.99	BRUSH BLOCK PAIR (carbon blocks only)		1
4	145-640	\$8.29	MOUNTING KIT (3 grommets, studs, nuts & washers)		1
7	145-320	NA	GEAR & SHAFT		1
8	161-310	\$15.99	CABLE ASS'Y., must be cut to match original length		1
9	145-200	\$36.99	WHEELBOX		2
10	145-290	\$3.89	BEZEL, chrome		2
11	282-820	\$0.69	PAD, bezel		2
12	311-065	\$1.69	NUT		2
14	165-005	\$19.99	WIPER ARM (LHD)		2
15	161-100	\$19.99	WIPER BLADE, 8"		2

## Sprite MkIII-IV, Midget MkII-III thru 1967

1	145-510	NA	WIPER MOTOR, less gear #7	{ replaces units #75452, 75504 & 75801, 1963-'67	1
2	554-030	NA	BRUSH ASSEMBLY		1
3	554-035	\$19.99	BRUSH PAIR (carbon blocks only)		1
4	145-640	\$8.29	MOUNTING KIT (3 grommets, studs, nuts & washers)		1
7	145-535	NA	GEAR & SHAFT	{ original units #75452 & 75504	1
	560-360	\$104.99	GEAR & SHAFT	replacement unit #75801	1
8	161-310	\$15.99	CABLE ASS'Y., must be cut to match original		1
9	145-217	\$37.99	WHEELBOX		2
10	145-290	\$3.89	BEZEL, chrome		2
11	282-820	\$0.69	PAD, bezel		2
12	145-205	\$1.79	NUT		2
14	165-005	\$16.75	WIPER ARM (LHD)		2
15	161-100	\$18.95	WIPER BLADE, 8"		2

## All from 1968 on

5	145-490	\$89.99	WIPER MOTOR, less gear #7	} replaces units #75660, 75664 & 75705	1
	145-485	\$109.99	WIPER MOTOR, less gear, Lucas		1
5a	145-590	\$19.99	BRUSH SET		1
6	145-645	\$6.89	STRAP, wiper motor mounting		1
6a	145-660	\$3.79	PAD		1
6b	145-665	NA	PACKING		1
7	145-575	\$39.99	GEAR & SHAFT	twin wipers	1
	145-555	\$18.89	GEAR & SHAFT	triple wipers	1
8	161-310	\$15.99	CABLE ASS'Y., must be cut to match original	original	1
9	145-150	NA	WHEELBOX	1968 - '74 1/2	2/3
	145-140	NA	WHEELBOX	1974 1/2 on	3
10	145-290	\$3.89	BEZEL, chrome		2/3
11	282-820	\$0.69	PAD, bezel		2/3
12	145-205	\$1.79	NUT		2/3

LOCAL & OVERSEAS: 805-681-3400

FAX: 805-692-2525 www.mossmotors.com

MOSS

# Headlamps

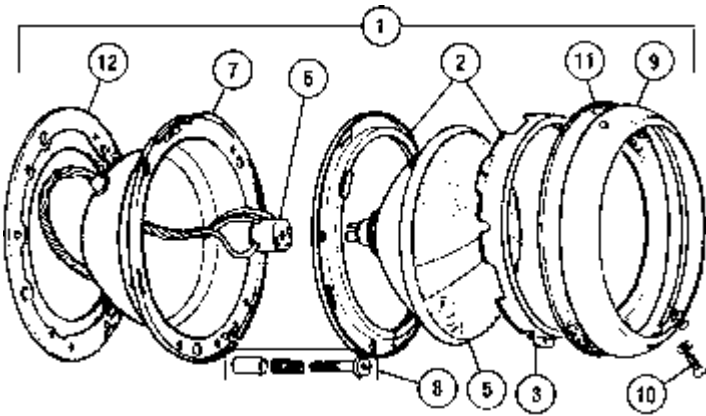

No.	Part No.	Price (each)	Description	Application	Qty. Req.
<b>Headlamps - Bugeye to (c)19014</b>					
1	168-708	\$94.99	HEADLAMP ASS'Y., sealed beam		2
2	157-300	\$18.79	RING ASS'Y., inner, 2 piece		2
3	156-700	\$6.49	RING, retaining		2
5	171-100	NA	LIGHT UNIT, sealed beam (not in ass'y.)		2
	171-105	\$13.99	LIGHT UNIT, sealed beam, halogen (in ass'y.)		2
6	171-400	\$5.89	PLUG, sealed beam, w/ grommet & pigtail		2
7	144-797	\$19.99	BUCKET (3 adjuster type) without adjusters		2
8	147-015	\$12.79	ADJUSTER SET, for 1 lamp		2
9	164-002	\$21.79	CHROME RIM, outer		2
10	147-000	\$0.99	SCREW		2
11	280-120	\$2.19	DUST SEAL		2
12	280-130	\$2.49	GASKET, lamp ass'y., to body		2

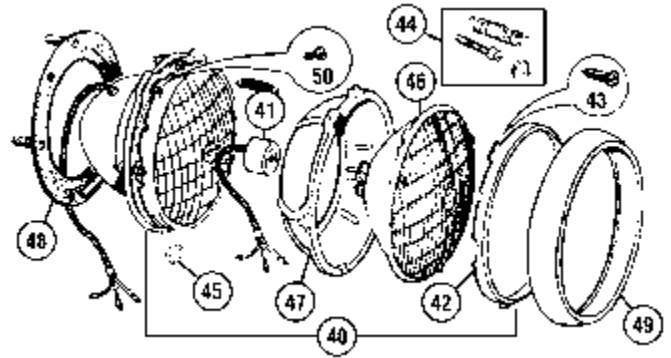

No.	Part No.	Price (each)	Description	Application	Qty. Req.
<b>Headlamps - Midget 1500</b>					
40	144-810	\$63.99	HEADLAMP ASSEMBLY		2
	169-130	NA	BUCKET ASSEMBLY		2
	144-807	\$20.99	BUCKET, bare		2
41	171-400	\$5.89	PLUG, w/grommet & pigtail		2
42	156-700	\$6.49	RING, retaining		2
43	158-045	\$0.34	SCREW		6
44	552-115	\$4.99	ADJUSTER SET		2
45	560-325	\$2.19	CLIP, rim securing		2
46	171-100*	NA	LIGHT UNIT, sealed beam (not in ass'y.)		2
	171-105	\$13.99	LIGHT UNIT, sealed beam, halogen (in ass'y.)		2
47	560-215	\$14.99	RIM, inner		2
48	164-060	\$3.99	GASKET, lamp ass'y., to body		2
49	164-020	\$19.99	RIM, outer (1975-'79)		2
	164-015	\$54.99	RIM, outer, with notch (1980)		2
50	373-960	\$0.20	SCREW, to body		8

\* Note: See the Accessories Section at the front of this catalog for alternative headlamps.

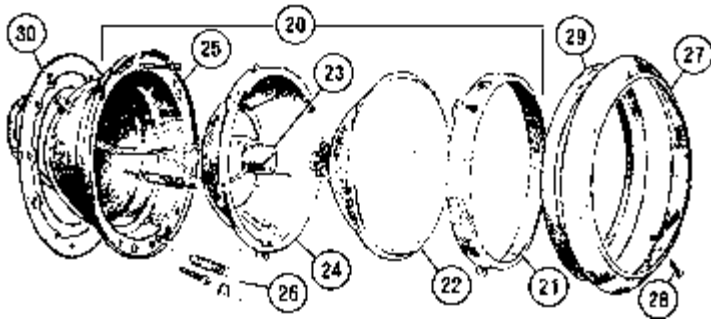

## Headlamps - from Bugeye (c)19015 thru 1275

20	144-800	\$89.99	HEADLAMP ASS'Y., sealed beam		2
21	156-700	\$6.49	RING, retaining		2
22	171-100	NA	LIGHT UNIT, sealed beam (not in ass'y.)		2
	171-105	\$13.99	LIGHT UNIT, sealed beam, halogen (in ass'y.)		2
23	171-400	\$5.89	PLUG, sealed beam, w/ grommet & pigtail		2
24	560-215	\$14.99	RIM, inner		2
25	144-807	\$20.99	BUCKET with 2 adjusters		2
26	552-115	\$4.99	ADJUSTER SET, for 1 lamp		2
27	164-000	NA	CHROME RIM, outer, orig. type	} Bugeye	2
	164-002	\$21.79	CHROME RIM, replacement		2
	560-180	\$18.79	CHROME RIM, outer		all except Bugeye
28	147-000	\$0.99	SCREW		2
29	280-120	\$2.19	DUST SEAL	} Bugeye	2
30	280-130	\$2.49	GASKET, lamp ass'y., to body		2
	164-050	\$4.39	GASKET, lamp ass'y., to body	all except Bugeye	2

Your headlamps won't light! Check the ground connector on the passenger side inner fender under the fresh air tube clamp on 948 - 1275 models.

Most lamp problems are caused by bad bulb contacts or corroded grounds. Don't assume major problems until the unit is completely inspected.



## Halogen Headlamps

A	162-726	\$46.99	HALOGEN HEADLAMP, Lucas	2
B	902-969	\$74.99	HALOGEN HEADLAMP, Hella	2
C	156-875	\$39.99	HALOGEN HEADLAMP, Crystal Clear	2
	902-998	\$5.99	BULB, H4 halogen	2

See "Exterior" color pages at the front of this catalog for details

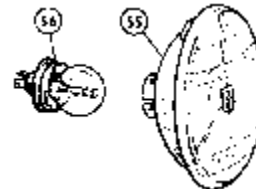

## PL Tripod Headlamps

	156-898	\$179.99	PL TRIPOD HEADLAMP SET* two light units with bulbs	} LHD	1
55	163-980	\$99.99	PL LIGHT UNIT*		2
56	170-450	\$3.49	BULB		2
	170-675	\$6.79	BULB, quartz halogen replacement		2

\*Note: These are reproductions with all of the correct Lucas markings. Tripod headlamps are semi-sealed units with replaceable bulbs, and are not legal for street use where D.O.T. approved headlamps are required.

MOSS

MOSS MOTORS, LTD.  
TOLL-FREE ORDERS

1-800-667-7872

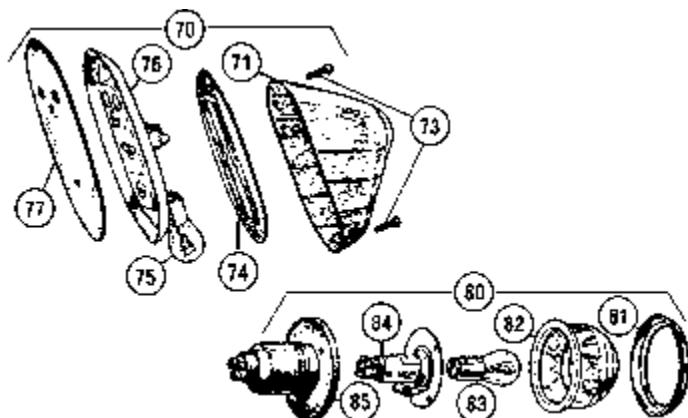
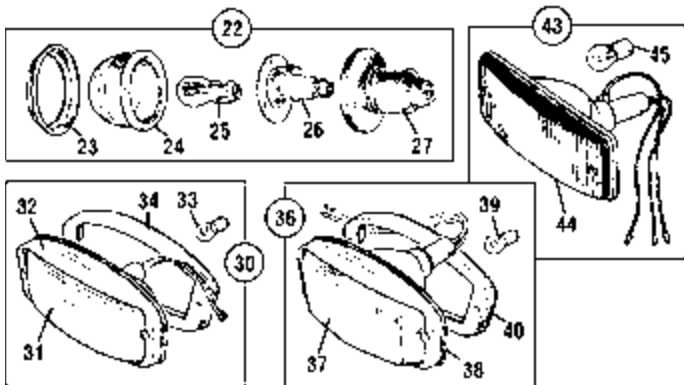

No.	Part No.	Price (each)	Description	Application	Qty. Req.
<b>Front Side/Flashers</b>					
22	544-050	\$21.89	LAMP ASSEMBLY, side/flasher	Bugeye	2
23	158-400	\$3.39	RIM, chrome		2
24	560-270	\$6.29	LENS, clear		2
25	170-700	\$0.59	BULB, original type		2
	170-931*	\$24.99	BULB, LED, white*		2
26	552-120	\$10.29	SOCKET		2
27	159-600	\$2.19	BODY, rubber		2
30	159-060	NA	LAMP ASSEMBLY, side/flasher clear lens (use #36 as repl.)	1961 - '67	2
	159-065	NA	LAMP ASSEMBLY, side/flasher amber lens (use #36 as repl.)	1968 - '69	2
31	159-048	\$36.99	LENS PAIR, clear (replacement - Euro-spec, glass)	1961 - '67	1
	159-075	NA	LENS, amber	1968 - '69	2
32	159-050	\$14.79	RIM	1961 - '69	2
33	170-700	\$0.59	BULB, original type		2
	170-931*	\$24.99	BULB, LED, white*		2
	170-936*	\$24.99	BULB, LED, amber*		2
34	159-085	\$3.39	GASKET, lens seating		2
36	159-090	\$59.99	LAMP ASSEMBLY, side/flasher		2
37	159-095	\$10.79	LENS, amber		2
38	159-050	\$14.79	RIM	Midget 1970-'74	2
39	170-700	\$0.59	BULB, original type		2
	170-937*	\$37.99	BULB KIT, LED, amber* (Bulb Kit includes 1 bulb and 1 ballast)		2
40	159-085	\$3.39	GASKET, lens seating		2
43	164-155	\$69.99	LAMP ASSEMBLY, side/flasher, Lucas	Midget 1500	2
	164-156	NA	LAMP ASSEMBLY, side/flasher, reproduction		2
44	164-815	\$7.89	LENS, amber, with screw & seal		2
	323-035	\$0.89	SCREW, lens to base		2
	164-120	\$1.69	SEAL, lens to base		2
45	170-700	\$0.59	BULB		2
	170-937*	\$37.99	BULB KIT, LED, amber* (Bulb Kit includes 1 bulb and 1 ballast)		2

No.	Part No.	Price (each)	Description	Application	Qty. Req.
<b>Taillight - Bugeye</b>					
70	143-800	\$32.99	TAIL LAMP ASSEMBLY	Bugeye	2
71	159-200	NA	LENS, Lucas		2
	159-210	\$9.99	LENS, aftermarket, marked "Lucas"		2
73	323-420	\$2.59	SCREW for lens		4
74	159-100	\$2.69	PAD, lens mounting		2
75	170-700	\$0.59	BULB, original type		2
	170-941*	\$24.99	BULB, LED, red*		2
76	159-300	\$19.99	BASE ASSEMBLY, chrome		2
77	159-400	\$2.39	PAD, lamp mounting		2
80	144-000	\$21.99	FLASHER LAMP ASSEMBLY		2
81	158-400	\$3.39	RIM, chrome		2
82	164-900	\$7.69	LENS, red		2
83	170-800	\$0.79	BULB, original type		2
	170-956*	\$25.99	BULB, LED, red*		2
84	159-900	\$10.29	SOCKET		2
85	159-600	\$2.19	BODY, rubber	2	

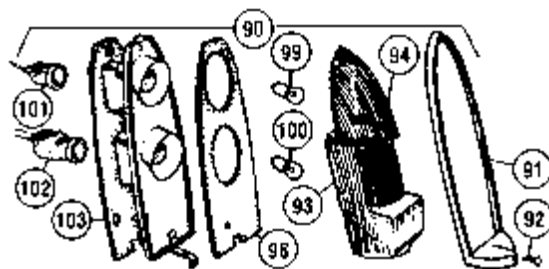
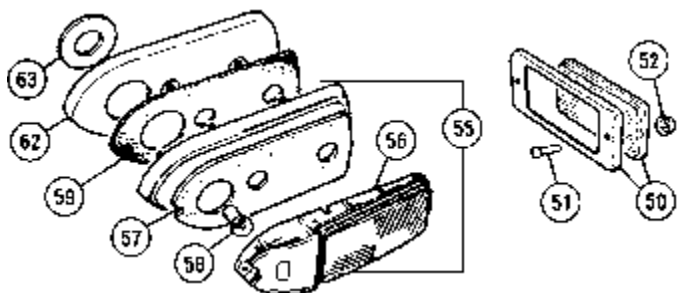

No.	Part No.	Price (each)	Description	Application	Qty. Req.
<b>Front Side Markers</b>					
50	570-180	\$16.89	REFLECTOR & RIM, front, amber	1275, 1968 - '69	2
51	158-230	NA	RIVET, reflector to body		4
52	158-235	NA	PUSH-ON FIX, rivet		4
55	164-845	\$58.99	SIDE MARKER, L/H front	Midget 1970 on	1
	164-855	\$58.99	SIDE MARKER, R/H front		1
56	164-885	\$21.79	LENS, L/H		1
	164-890	\$21.79	LENS, R/H		1
57	164-910	\$1.29	GASKET, lens seating		2
58	170-250	\$0.39	BULB, original type		2
	170-911*	\$19.99	BULB, LED, amber*		2
59	164-915	\$4.79	GASKET, lamp to plinth		2
62	NA	NA	PLINTH, L/H		1
	NA	NA	PLINTH, R/H		1
63	164-130	NA	WASHER, sealing		2

No.	Part No.	Price (each)	Description	Application	Qty. Req.
<b>Taillight - 1961-1969</b>					
90	144-390	\$72.99	TAIL LAMP ASS'Y., w/red/red lenses	from Sprite MkII & Midget MKI thru 1969	2
91	164-790	\$14.49	RIM		2
92	323-090	\$1.09	SCREW		2
93	164-820	\$13.39	LENS, stop/tail, original Lucas		2
94	164-830	\$6.99	LENS, flasher, original Lucas		2
	164-725	\$9.89	LENS, flasher, amber (Euro. spec.)		2
98	164-840	\$2.19	PAD, lens seating		2
99	170-800	\$0.79	BULB, original type, flasher		2
	170-951*	\$25.99	BULB, LED, flasher, amber*		2
	170-956*	\$25.99	BULB, LED, flasher, red*		2
100	170-700	\$0.59	BULB, original type, stop/tail		2
	170-941*	\$24.99	BULB, LED, stop/tail, red*		2
101	158-150	\$1.29	GROMMET, flasher wire		2
102	158-160	NA	GROMMET, stop/tail wire		2
103	164-870	\$1.19	PAD, lamp to car		2

\*Note: For Negative Ground vehicles only. You will want to match LED bulb color with the color of the specific lamp lens to avoid color distortion. Use White for Clear, Amber for Amber, and Red for Red. In some applications there were multiple options, so the appropriate selection must be made based on your vehicle. If you are replacing turn signal bulbs with LEDs you will need to upgrade to an electronic flasher. Flasher part numbers are 141-667 for 2-Prong, or 141-668 for 3-Prong.

# Lamps

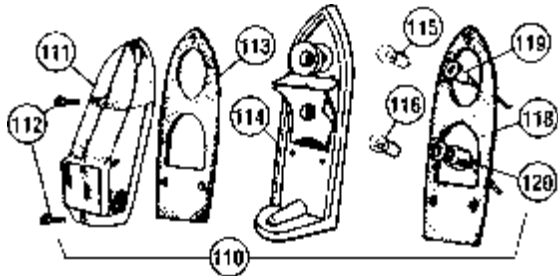

No.	Part No.	Price (each)	Description	Application	Qty. Req.
<b>Taillight - Midget 1970 on</b>					
110	144-395	\$113.99	TAIL LAMP ASSEMBLY, w/ 1 pc. lens	} Midget, 1970 on	2
111	164-835	\$32.99	LENS, Lucas		2
	164-735	NA	LENS, quality replacement		2
112	323-035	\$0.89	SCREW, lens to base		4
113	164-883	\$1.99	GASKET, lens seating		2
114	164-785	NA	LAMP BASE, chrome		2
115	170-700	\$0.59	BULB, original type, stop/tail		2
	170-941*	\$24.99	BULB, LED, stop/tail, red*		2
116	170-800	\$0.79	BULB, flasher		2
	170-952	\$37.99	BULB KIT, LED, flasher, amber* (Bulb Kit includes 1 bulb and 1 ballast)		2
118	164-880	\$1.49	GASKET, lamp to car		2
119	158-160	NA	GROMMET, stop/tail wires		2
120	158-150	\$1.29	GROMMET, flasher wire	2	

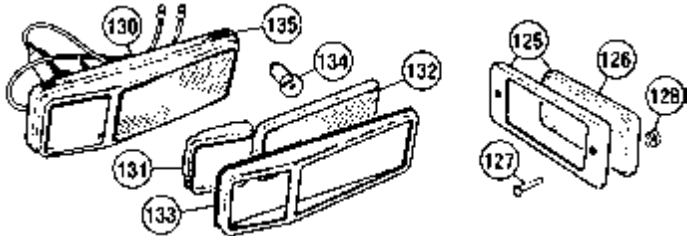

No.	Part No.	Price (each)	Description	Application	Qty. Req.
<b>Rear Side Markers</b>					
125	144-720	\$12.79	REFLECTOR & RIM, rear, red	} 1275, 1968 - '69	2
126	164-150	\$11.99	REFLECTOR, red		2
127	158-230	NA	RIVET, reflector to body		4
128	158-235	NA	PUSH-ON FIX, rivet		4
130	164-135	\$139.99	SIDE MARKER ASSEMBLY, rear	} Midget, 1970 on	2
131	164-140	NA	LENS, red		2
132	164-150	\$11.99	REFLECTOR, red		2
133	164-145	\$99.99	RIM		2
134	170-250	\$0.39	BULB, original type		2
	170-916*	\$19.99	BULB, LED, red*		2
135	282-260	\$14.99	BASE, rubber	2	

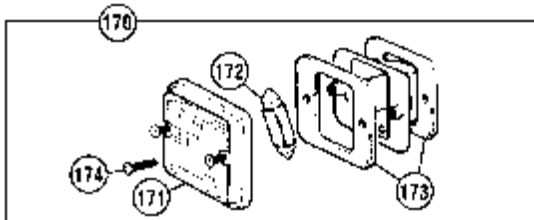

No.	Part No.	Price (each)	Description	Application	Qty. Req.
<b>Reverse Lamps</b>					
170	144-595*	\$22.99	REVERSE LAMP, Lucas*	} 1275 & 1500	2
	144-590*	\$11.39	REVERSE LAMP, aftermarket*		2
171	164-861	\$8.69	LENS w/gasket & screws, Lucas		2
	164-860	NA	LENS w/ gasket, aftermarket		2
172	170-140	\$0.69	BULB		2
173	159-110	\$1.19	PAD, lens & lamp seating		4
174	158-220	\$0.49	SCREW	4	

\*Screws supplied with lamps must be replaced with no.174 158-220.

### Chrome Reverse Lamp Rims

The original reverse lamp lenses have never been a thing of beauty, now that can be changed. These chrome plated brass rims fit over the original lens to brighten the rear of the car. Available individually or as a set of two with new lenses, and installation screws.

Chrome Rim (ea.) **164-862 \$19.89**  
 Chrome Rim & Lens Set **164-868 \$49.99**

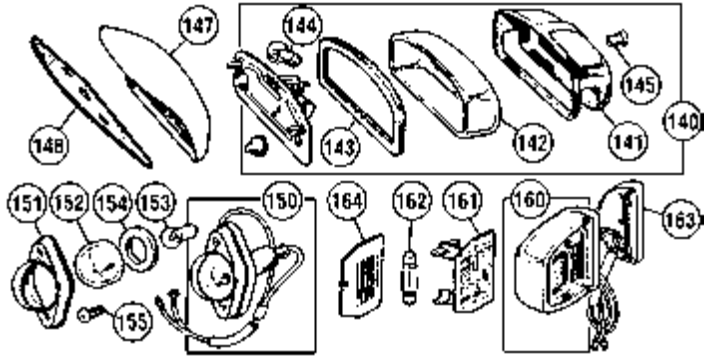

No.	Part No.	Price (each)	Description	Application	Qty. Req.	
<b>License Lamps</b>						
140	144-190	\$69.99	LICENSE PLATE LAMP, "England"	} all thru 1969	1	
	144-200	\$21.99	LICENSE PLATE LAMP, Classic Gold		1	
141	158-100	\$12.69	COVER, chrome		1	
142	164-100	\$6.49	LENS		1	
143	280-540	\$2.39	SEAL, lens to base		2	
144	170-250	\$0.39	BULB, original type		1	
	170-906*	\$18.99	BULB, LED, white*		2	
145	158-200	\$2.19	SCREW, cover		1	
147	144-240	\$84.99	PLINTH, lamp mounting		} Bugeye	1
148	159-020	\$7.99	GASKET, plinth to body			1
	159-025	\$2.89	GASKET, plinth to body	} Sprite MkII on Midget thru 1969	1	
150	144-180	\$72.89	LICENSE PLATE LAMP ASS'Y.		2	
151	158-510	\$12.49	COVER	} Midget 1970 - 74 split rear bumper	2	
152	158-500	\$6.39	LENS		2	
153	170-250	\$0.39	BULB, original type		2	
	170-906*	\$18.99	BULB, LED, white*		2	
154	158-520	\$2.39	PAD, lens seating		2	
155	159-330	\$0.89	SCREW, lamp mounting		4	
160	144-220	\$19.89	LICENSE LAMP ASS'Y., chrome	} Midget 1500 to (c)182000	2	
161	158-915	\$5.49	LENS & BULB HOLDER		2	
162	170-010	\$0.39	BULB, stock type	} Midget 1500 from (c)182001	2	
	170-996*	\$10.99	BULB, LED replacement*		2	
163	144-225	\$2.69	GROMMET, base	2		
	144-230	\$19.29	LICENSE LAMP ASS'Y., black	2		
164	158-910	\$4.49	LENS	} Midget 1500 from (c)182001	2	
	170-010	\$0.39	BULB, stock type		2	
	170-996*	\$10.99	BULB, LED replacement*		2	

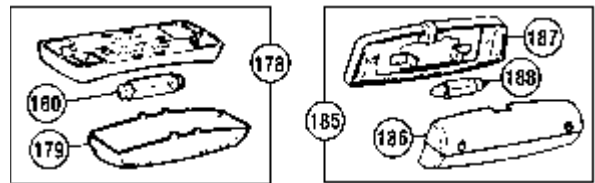

No.	Part No.	Price (each)	Description	Application	Qty. Req.
<b>Interior Lamps</b>					
178	158-940	\$16.29	TRUNK LAMP, interior	} Sprite MkIII on Midget MkII on	1
179	158-945	NA	LENS		1
180	170-010	\$0.39	BULB, stock type		1
	170-996*	\$10.99	BULB, LED replacement*		1
185	158-920	\$13.99	COURTESY LAMP, fixed		1
186	158-925	\$13.99	LENS & BEZEL		1
187	158-930	NA	PLATE & SWITCH		1
188	170-010	\$0.39	BULB, stock type		1
	170-996*	\$10.99	BULB, LED replacement*		1
	314-280	\$0.49	SCREW, courtesy lamp		2
	317-045	\$0.59	FIX NUT for screw	2	

\*Note: For Negative Ground vehicles only. You will want to match LED bulb color with the color of the specific lamp lens to avoid color distortion. Use White for Clear, Amber for Amber, and Red for Red. In some applications there were multiple options, so the appropriate selection must be made based on your vehicle. If you are replacing turn signal bulbs with LEDs you will need to upgrade to an electronic flasher. Flasher part numbers are 141-667 for 2-Prong, or 141-668 for 3-Prong.

**MOSS** **MOSS MOTORS, LTD.** **TOLL-FREE ORDERS** **1-800-667-7872**



# Wiring Harnesses

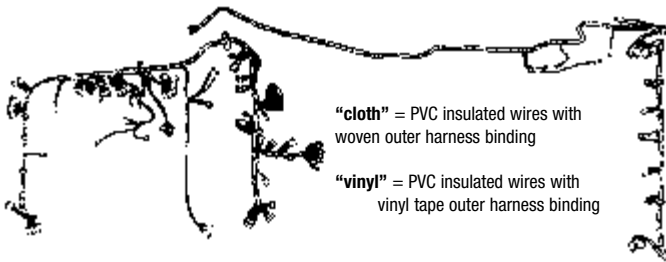

"cloth" = PVC insulated wires with woven outer harness binding

"vinyl" = PVC insulated wires with vinyl tape outer harness binding

New harnesses have some non-original dash lamp sockets replacing socket no. 14 in the illustration to the right. These use wedge-base bulbs below.

170-150	\$0.79	BULB, wedge base, 3 watt	new wiring harnesses	A/R
170-030	\$0.79	BULB, wedge base, 5 watt	new wiring harnesses	A/R
170-690	\$0.69	BULB, wedge base, 1.2 watt	new wiring harnesses	A/R

356-910	\$369.99	MAIN HARNESS, vinyl	} GAN6-159054 to 166300 (1500)
356-988	\$219.99	DASH HARNESS, vinyl	
356-917	NA	REAR HARNESS, vinyl	
356-920	\$369.99	MAIN HARNESS, vinyl	} GAN6-166301 to 188000 (Federal)
356-988	\$219.99	DASH HARNESS, vinyl	
356-917	NA	REAR HARNESS, vinyl	
356-920	\$369.99	MAIN HARNESS, vinyl	} GAN6-166301 to 200000 (California)
356-988	\$219.99	DASH HARNESS, vinyl	
356-917	NA	REAR HARNESS, vinyl	
356-947	NA	MAIN HARNESS, vinyl	} GAN6-188001 to 200000 (Federal)
356-988	\$219.99	DASH HARNESS, vinyl	
356-917	NA	REAR HARNESS, vinyl	
356-957	NA	MAIN HARNESS, vinyl	} GAN6-200001 on (Federal)
356-998	NA	DASH HARNESS, vinyl	
356-917	NA	REAR HARNESS, vinyl	
356-967	NA	MAIN HARNESS, vinyl	} GAN6-200001 to 212000 (California)
356-998	NA	DASH HARNESS, vinyl	
356-917	NA	REAR HARNESS, vinyl	
356-977	NA	MAIN HARNESS, vinyl	} GAN6-212001 on (California)
356-998	NA	DASH HARNESS, vinyl	
356-917	NA	REAR HARNESS, vinyl	

\*Note: These wiring harnesses include main and body-rear harness. All harnesses may not include minor sub-harnesses such as headlight to headlight, horn to horn, dimmer switch, and dash light wires.

## Sprite Wiring Harnesses

356-100*	\$349.99	WIRING HARNESS, cloth	{ HAN5-501 to 50116 1958 - '61 (Bugeye)
355-015*	\$379.99	WIRING HARNESS, cloth	{ HAN6-101 to 24731 1961 - '62 (MkII) 948
355-025*	\$389.99	WIRING HARNESS, cloth	{ HAN7-24732 to 38828 1962 - '64 (MkII) 1098
355-035*	\$459.99	WIRING HARNESS, cloth	{ HAN8-38829 to 64734 1964 - '67 (MkIII)
356-805*	\$439.99	WIRING HARNESS, cloth	{ HAN9-64735 to 70267 (MkIV)
356-815*	\$459.99	WIRING HARNESS, cloth	{ HAN9-70268 to 72033 (MkIV)
356-828*	NA	WIRING HARNESS, cloth	{ HAN9-72034 to 77590 (MkIV)
356-830*	\$309.99	MAIN HARNESS, vinyl	} HAN9-77591 to 85286 (MkIV)
356-807*	\$114.99	REAR HARNESS, vinyl	
356-840*	\$379.99	MAIN HARNESS, vinyl	} HAN10-85287 on (MkIV)
356-847*	\$104.99	REAR HARNESS, vinyl	

## Midget Wiring Harnesses

355-015*	\$379.99	WIRING HARNESS, cloth	{ GAN1-101 to 16183 1961 - '62 (MkI)
355-025*	\$389.99	WIRING HARNESS, cloth	{ GAN2-16184 to 25787 1962 - '64 (MkI)
355-035*	\$459.99	WIRING HARNESS, cloth	{ GAN3-25788 to 52389 1964 - '66 (MkII)
356-805*	\$439.99	WIRING HARNESS, cloth	{ GAN4-52390 to 58111 (MkIII)
356-815*	\$459.99	WIRING HARNESS, cloth	{ GAN4-58112 to 60440 (MkIII)
356-828*	NA	WIRING HARNESS, cloth	{ GAN4-60441 to 66225 (MkIII)
356-830	\$309.99	MAIN HARNESS, vinyl	} GAN4-66226 to 74885 (MkIII)
356-807	\$114.99	REAR HARNESS, vinyl	
356-840	\$379.99	MAIN HARNESS, vinyl	} GAN5-74886 to 89514 (MkIII)
356-847	\$104.99	REAR HARNESS, vinyl	
356-850	\$419.99	MAIN HARNESS, vinyl	} GAN5-89515 to 105500 (MkIII)
356-857	\$139.99	REAR HARNESS, vinyl	
356-860	\$239.99	MAIN HARNESS, vinyl	} GAN5-105501 to 112275 (MkIII)
356-867	\$119.99	REAR HARNESS, vinyl	
356-870	\$419.99	MAIN HARNESS, vinyl	} GAN5-112276 to 123730 (MkIII)
356-877	\$96.99	REAR HARNESS, vinyl	
356-880	\$399.99	MAIN HARNESS, vinyl	} GAN5-123731 to 138000 (MkIII)
356-877	\$96.99	REAR HARNESS, vinyl	
356-890	\$389.99	MAIN HARNESS, vinyl	} GAN5-138001 to 154100 (MkIII)
356-897	NA	REAR HARNESS, vinyl	
356-900	\$349.99	MAIN HARNESS, vinyl	} GAN6-154101 to 159053 (1500)
356-988	\$219.99	DASH HARNESS, vinyl	
356-907	NA	REAR HARNESS, vinyl	

## Sub-Harnesses

356-825	\$19.99	DIMMER SWITCH HARNESS	Sprite MkI,II, Midget MkI	1
356-835	\$28.99	DIMMER SWITCH HARNESS	Sprite MkIII,IV, Midget MkII,III	1

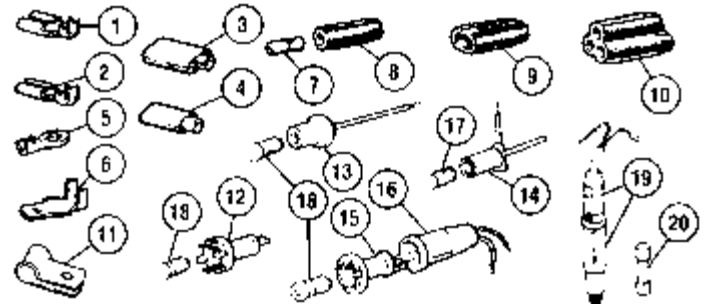

## Wiring Fittings

1	161-580	\$0.69	CLIP, 35 amp (3/8")	A/R
2	161-520	\$0.49	CLIP, 17.5 amp (1/4")	A/R
3	161-540	\$0.59	INSULATOR, 35 amp clip	A/R
4	161-570	\$0.19	INSULATOR, 17.5 amp clip	A/R
5	161-740	\$0.49	EYELET, 3/16"	A/R
	161-750	NA	EYELET, 1/4"	A/R
	161-760	\$0.49	EYELET, 5/16"	A/R
6	162-205	\$0.39	BLADE, 1/4"	A/R
7	162-200	\$0.39	WIRE NIPPLE	A/R
8	162-000	\$0.39	CONNECTOR, single	A/R
9	161-600	\$0.49	CONNECTOR, double	A/R
10	161-720	\$11.99	CONNECTOR, triple	A/R
11	470-830	\$0.89	CLIP, 1/4" cable dia. 7/32" hole	A/R
	162-210	\$1.19	CLIP, 1/4" cable dia. 9/32" hole	A/R
	162-250	\$0.89	CLIP, 3/8" cable dia. 7/32" hole	A/R
	162-310	\$1.19	CLIP, 5/8" cable dia. 9/32" hole	A/R
12	161-915	\$6.29	BULB HOLDER (orig. type)	A/R
13	158-330	NA	BULB HOLDER (orig. type)	A/R
	158-332	\$12.99	BULB HOLDER, replacement	uses bulb below
	170-150	\$0.79	BULB for 158-332	A/R
14	158-340	NA	BULB HOLDER (orig. type)	A/R
	158-345	\$8.99	BULB HOLDER, replacement	uses bulb below
	170-690	\$0.69	BULB for 158-345	A/R
15	158-320	\$6.39	BULB HOLDER (orig. type)	A/R
16	158-360	NA	SLEEVE, bulb holder	A/R
17	170-110	\$0.49	BULB, "eared" base	A/R
18	171-000	\$0.89	BULB, screw base	A/R
19	146-750	\$1.89	FUSE HOLDER, in-line	A/R
20	146-730	\$0.59	FUSE, 10 amp (for in-line holder)	A/R

## Wiring Harness Tape



This tape is not self-adhesive. Examine your old harness carefully to see how ends and branches are accomplished.

162-030 Blue Harness Tape \$13.99  
162-025 Black Harness Tape \$8.99

LOCAL & OVERSEAS: 805-681-3400  
FAX: 805-692-2525 www.mossmotors.com



# Distributors - 948-1275

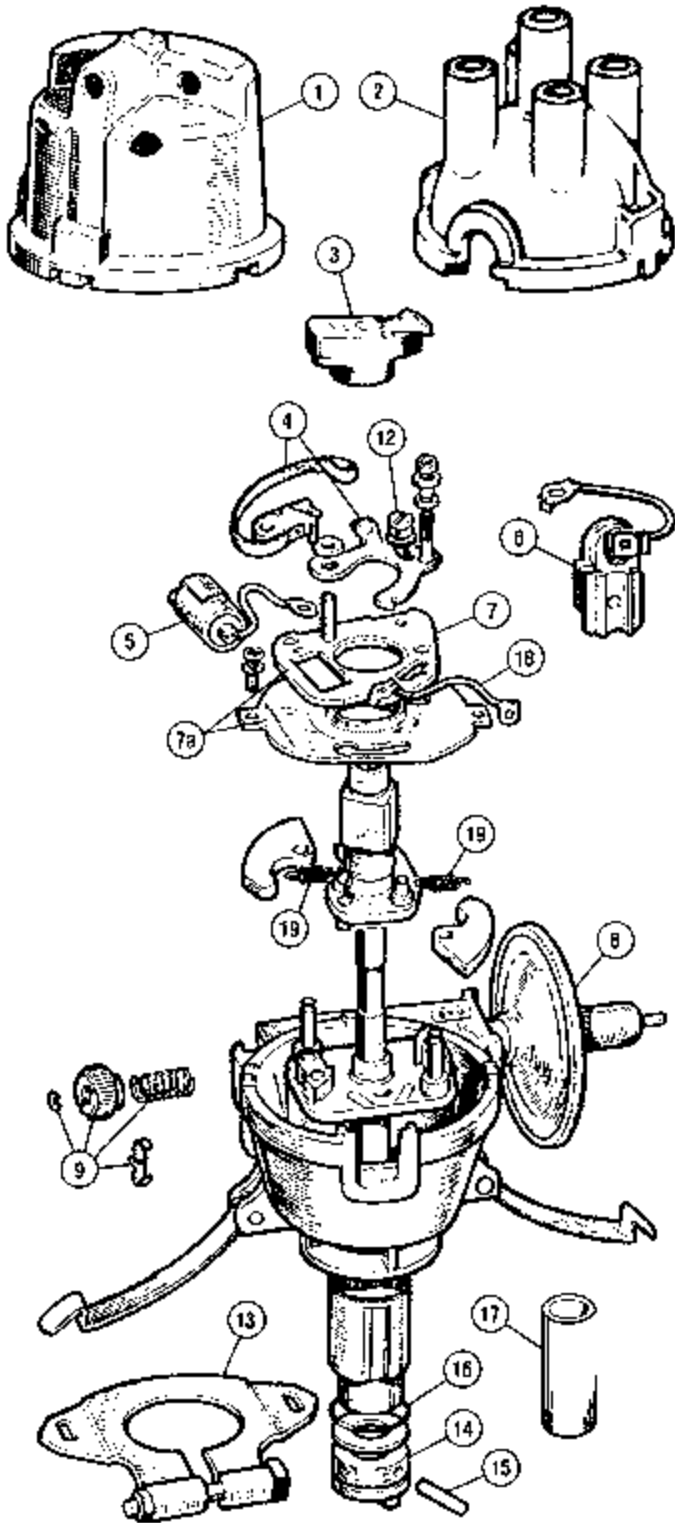

No.	Part No.	Price (each)	Description	Application	Qty. Req.
1	163-825	\$29.99	DISTRIBUTOR CAP, side entry, Intermotor brand		1
	163-800	\$13.89	DISTRIBUTOR CAP, side entry, aftermarket		1
2	163-815	NA	DISTRIBUTOR CAP, top entry, Lucas		1
	163-810	\$8.99	DISTRIBUTOR CAP, top entry, aftermarket		1
3	151-805	\$6.99	ROTOR, premium replacement		1
	151-710	\$2.39	ROTOR, Lucas		1
	151-805	\$6.99	ROTOR, Premium aftermarket		1
	151-800	\$4.39	ROTOR, aftermarket		1
	152-220	\$7.99	CONDENSER & POINT SET, Lucas		1
	152-221	\$9.99	CONDENSER & POINT SET, Intermotor brand		1
4	151-720	\$2.89	POINT SET, Lucas		1
	152-225	\$19.99	POINT SET, Premium aftermarket		1
	153-900	\$5.49	POINT SET, aftermarket		1
5	151-730	\$3.39	CONDENSER, Lucas		1
	154-001	\$8.99	CONDENSER, Premium aftermarket		1
6	153-600	\$11.99	TERMINAL & LEAD	DM2P4 models	1
	153-640	\$3.99	TERMINAL & LEAD	25D models	1
7	153-700	\$59.99	BREAKER PLATE (upper)	DM2P4 models	1
7a	551-055	\$36.99	BREAKER PLATE ASS'Y.	25D models	1
8	163-696	\$88.99	VACUUM UNIT	{ Bugeye	1
				{ distributor #40561	
	163-697	\$88.99	VACUUM UNIT	{ 948-1098 1961-'62	1
				{ distributor #40752	
	163-698	\$88.99	VACUUM UNIT	{ 1098 1963-'66	1
				{ distributor #40919	
	163-675	\$88.99	VACUUM UNIT	1275	1
9	163-738	\$12.99	ADJUSTER KIT	DM2P4 models	1
	163-739	\$12.99	ADJUSTER KIT	25D models	1
12	NA	NA	SCREW, points retaining	DM2P4 models	1
	323-245	\$0.79	SCREW, points retaining	25D models	1
13	153-400	\$8.19	CLAMPING PLATE with bolt & nut (replacement)		1
	153-401	\$32.59	CLAMPING PLATE without bolt & nut (OE type)		1
	153-402	\$7.49	BOLT & NUT for clamping plate		1
14	153-300	\$17.99	DRIVING DOG		1
15	539-020	\$0.49	PIN		1
16	163-750	\$0.19	"O" RING	as fitted	1
17	153-500	\$31.09	BUSHING		1
18	153-645	\$2.49	GROUND WIRE (replacement)		1
19	551-010	\$17.99	SPRING SET (universal replacement - set of 5)		1

**"Opus"**

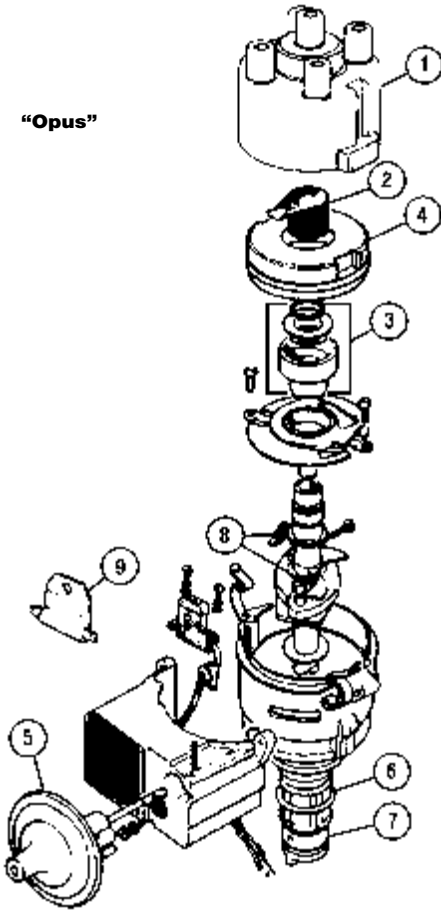

**C.E.I.**

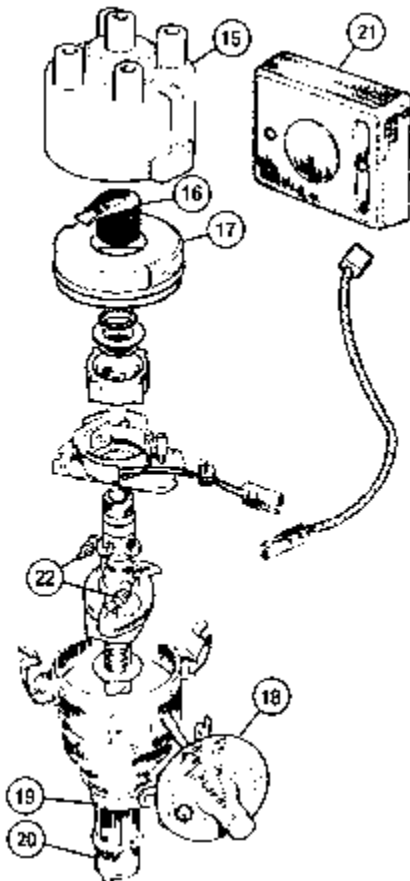

### Lucas Electronic Ignition

The original Lucas "Opus" electronic ignition system used through 1979 featured the amplifier module mounted on the distributor body. As this system proved notoriously troublesome and unreliable, all replacements made as of 1980 were of the C.E.I. (Constant Energy Ignition) type, with a remotely mounted amplifier. Needless to say, this has caused much confusion during the intervening years when replacement components have been required. Order parts based on your distributor number.

Model Year	Orig. Opus distributor#	Replacement C.E.I. distributor #
1975	41593	41804
1976 Fed.	41646	41805
1976 CA	41656	41804
1977-79 Fed.	41697	41807
1977-79 CA	41698	41808

No.	Part No.	Price (each)	Description	Application	Qty. Req.
<b>Opus System</b>					
1	151-875	\$6.59	CAP, Lucas		1
	151-870	\$8.49	CAP, aftermarket		1
2	151-865	\$6.99	ROTOR ARM, Premium		1
	151-855	\$2.39	ROTOR ARM, Lucas		1
	151-850	NA	ROTOR ARM, aftermarket		1
3	154-050	NA	TIMING ROTOR		1
4	154-030	NA	ANTI-FLASH COVER	{ Opus distr. #41593 & 41656	1
	154-040	NA	ANTI-FLASH COVER	{ Opus distr. #41646, 41697 & 41698	1
5	142-890	\$99.99	VACUUM UNIT	{ Opus distr. #41593 & 41656	1
	142-900	\$99.99	VACUUM UNIT	{ Opus distr. #41646, 41697 & 41698	1
6	163-750	\$0.19	O-RING		1
7	153-300	\$17.99	DRIVING DOG		1
	539-020	\$0.49	PIN for driving dog		1
8	551-010	\$17.99	SPRING SET (universal replacement - set of 5)		1
9	131-560	NA	DRIVE RESISTOR		1

### C.E.I. System

15	151-875	\$6.59	CAP, Lucas		1
	151-870	\$8.49	CAP, aftermarket		1
16	151-865	\$6.99	ROTOR ARM, Premium		1
	151-855	\$2.39	ROTOR ARM, Lucas		1
	151-850	NA	ROTOR ARM, aftermarket		1
17	154-040	NA	ANTI-FLASH COVER		1
18		NA	VACUUM UNIT	C.E.I. distr. #41804	1
	071-690	\$99.99	VACUUM UNIT	{ C.E.I. distr. #41805 & 41808	1
		NA	VACUUM UNIT	C.E.I. dist. #41807	1
19	163-750	\$0.19	O-RING		1
20	153-300	\$17.99	DRIVING DOG		1
	539-020	\$0.49	PIN for driving dog		1
21	142-975	NA	AMPLIFIER		1
22	551-010	\$17.99	SPRING SET (universal replacement - set of 5)		1

### Ignitor Electronic Ignition

- The solution to your Lucas distributor woes.
  - Completely self contained. Fits inside your original distributor
  - Simple installation. Only two wires to hook up. No permanent modifications involved.
  - No points to set or change.
  - Impervious to dust, moisture, or vibration and retains stock advance curve.
  - Much less affected by distributor shaft wear, firing accuracy to within 1/4°.
- (Distributor not included!)



Points-type distributor (positive ground)	222-555	\$124.99
Points-type distributor (negative ground)	222-405	\$112.99
1500 with Lucas electronic ignition	222-475	\$134.99

# Ignition

## Intermotor Sports Coils

40,000 volt output gives more reliable starting power, and greater performance at high rpm.

948-1275 (non-ballasted system) 143-201 \$42.99

1500 (ballasted system) 117-264 \$42.99

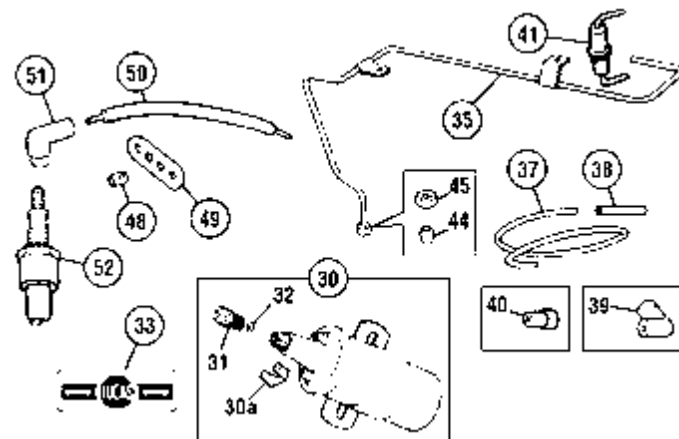

## FAST Electronic Ignition

This electronic conversion (formerly Crane) gives your ignition system a boost- in fact, a 35% increase in energy at the spark plugs. You retain your present distributor and coil, add the electronic module and sensor which replaces your points, condenser and rotor. Easy to install, this electronic conversion gives faster, cleaner running and better performance at all engine speeds. This unit works with both positive and negative ground systems.

222-680 \$179.99



## "Bumblebee" Ignition Wire

Its bright yellow and black coloring led to its descriptive nickname. This solid copper core wire is so good it was used for years by factory teams. Sold per foot.

571-020 \$5.29 per foot

No.	Part No.	Price (each)	Description	Application	Qty. Req.
30	543-020	\$32.99	COIL, w/screw connector (illus.)	thru 1967	1
	143-220	\$23.99	COIL, push-in connector, Lucas	} 1275 1968-'74	1
	143-221	\$18.59	COIL, push-in connector, aftermarket		1
	143-230	\$19.99	COIL		1500
	143-201	\$42.99	SPORTS COIL, Intermotor brand	not 1500	1
	117-264	\$42.99	SPORTS COIL, Intermotor brand	1500	1
30a	571-045	\$0.39	TERMINAL		A/R
31	152-400	\$1.29	NUT, wire securing	} used with and included 1 with coil #543-020	1
32	146-310	\$0.24	WASHER, brass		1
33	215-630	\$2.49	"LUCAS" COIL DECAL		1
35		NA	VACUUM LINE	948	1
		NA	VACUUM LINE	1098 & 1275	1
37	163-655	\$1.19	VACUUM LINE, plastic, per ft.	1275 & 1500	A/R
38	282-650	\$1.99	CONNECTOR, metal pipe to carb.	1098 & 1275	1
	153-830	\$1.19	CONNECTOR, plastic pipe to carb.	1275 & 1500	1
39	153-840	\$0.99	CONNECTOR		A/R
40		NA	CONNECTOR	} 1500	1
41	371-855	\$24.99	FUEL TRAP		2
44	163-635	\$0.89	COMPRESSION FITTING		1
45	153-810	\$4.19	NUT		1
48	171-630	\$4.29	WIRE LABEL SET, "1, 2, 3, 4"		1
49	171-550	\$2.89	IGNITION WIRE SEPARATOR		1
50	171-628	\$49.99	IGNITION WIRE SET, side entry cap	} 948, 1098, 1275	1
	171-660	\$28.99	IGNITION WIRE SET, top entry cap		1
	171-670	\$12.79	IGNITION WIRE SET, stock type	} 1500	1
	143-556	\$109.99	IGNITION WIRE SET, "Magnecore"		1
51	171-620	\$8.69	CLIP, suppressor	all	4
52	152-120	\$2.89	SPARK PLUG, Champion (std. type)	} 948-1098	4
	152-121	\$2.99	SPARK PLUG, Champion (resistor)		4
	175-080	\$3.39	SPARK PLUG, NGK (std. type)		4
	175-081	\$3.39	SPARK PLUG, NGK (resistor)		4
	152-130	\$2.89	SPARK PLUG, Champion	} 1275	4
	052-627	\$3.69	SPARK PLUG, NGK (std. type)		4
	115-332	\$3.39	SPARK PLUG, NGK (resistor)	} 1500	4
	860-051	\$2.89	SPARK PLUG, Champion (std. type)		4
	860-055	\$2.99	SPARK PLUG, Champion (resistor)		4



MOSS MOTORS, LTD.  
TOLL-FREE ORDERS

1-800-667-7872

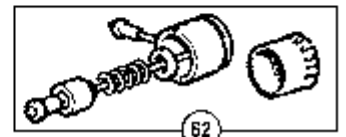
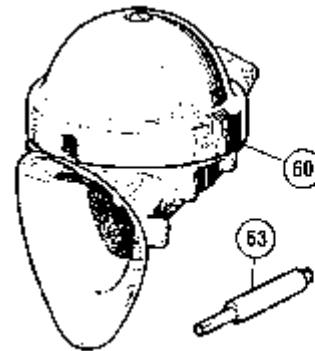
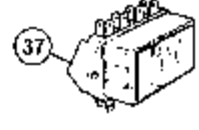
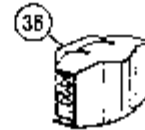
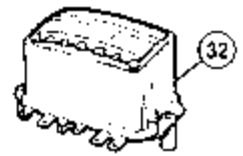
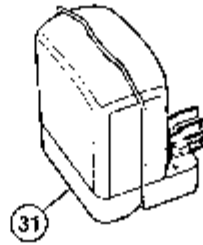
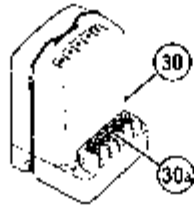
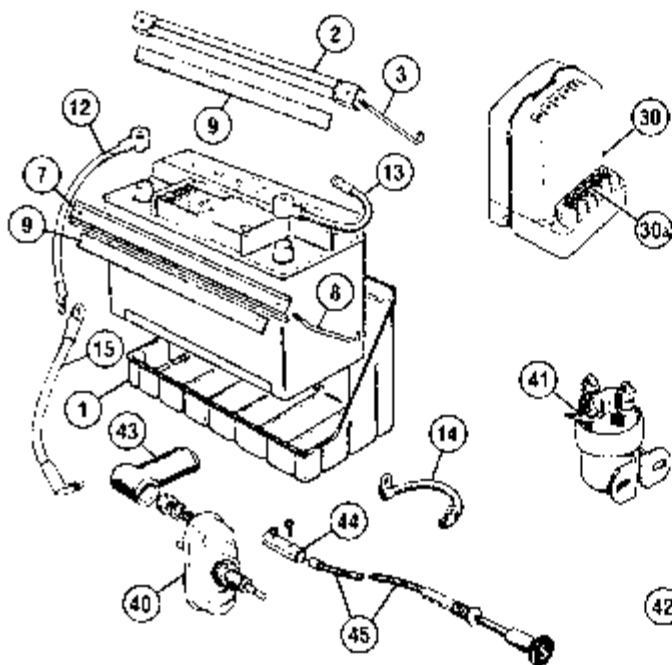

No.	Part No.	Price (each)	Description	Application	Qty. Req.
1	241-020	\$49.99	LINER, battery tray, 12"x7" battery	thru 1967	1
	241-060	\$19.99	BATTERY TRAY, OE flat type (for 10-1/4" x 5 1/2" battery)	1970-on	1
2	031-769	\$14.79	BRACKET, battery retaining	948, 1098 & 1275 (1967)	1
3	407-618	\$4.39	J-BOLT & NUT SET, 4 1/2"		1
7	473-185	\$6.99	BRACKET, battery retaining	1275 from 1968 & 1500	1
8	407-608	\$6.59	J-BOLT & NUT SET, 4"		1
9	473-115	\$1.49	PACKING		1
12	332-190	\$26.99	CABLE, battery to switch, repl.	pos. ground cars	1
		NA	CABLE, battery to switch, repl.	neg. ground cars	1
13	736-080	NA	CABLE, battery to body, orig. type	pos. ground cars	1
	736-085	\$31.99	CABLE, battery to body, replacement		1
	736-100	NA	CABLE, battery to body, orig. type	neg. ground cars	1
	736-105	\$31.99	CABLE, battery to body, replacement		1
14	736-220	\$18.59	GROUND STRAP, engine to body	948, 1098, 1275	1
	332-070	\$22.99	GROUND STRAP, engine to body	1500	1
15	332-170	\$21.99	CABLE, starter switch to starter	948, 1098 & 1275	1
	332-180	NA	CABLE, starter switch to starter	1500	1
30	142-003†	\$59.99	REGULATOR (tested & adjusted)	948 & 1098	1
30a	142-005	\$0.89	SCREW, wire retaining	screw terminals	5
31	542-101†	\$79.99	REGULATOR (tested & adjusted)	1098 & 1275 Lucar teminals	1
32	142-040†	NA	REGULATOR, Lucas	1275	1
	142-045†	\$36.99	REGULATOR, replacement		1
† These regulators are used with generator systems only. Original application change-points are complicated - replace like for like.					
35	162-500	\$9.99	FUSE BOX	Sprite Mkl-II, Midget Mkl	1
36	560-100	\$6.99	FUSE BOX	from above thru 1967	1
37	162-510	\$7.79	FUSE BOX	1968-'80	1
	560-115	\$2.89	COVER for 162-510		1
38	146-700	\$0.39	FUSE 35 amp		A/R
40	145-800	\$24.89	STARTER SWITCH	Sprite Mkl-II, Midget Mkl	1
41	546-020	\$19.79	SOLENOID	from above thru 1967	1
42	546-152	\$9.99	SOLENOID, reproduction	1968-'74	1
	131-506	\$27.99	SOLENOID, Lucas	1500	1
	131-505	\$10.49	SOLENOID, aftermarket		1
43	161-900	\$1.39	BOOT	all	2
44	161-500	\$8.89	COUPLING with screws	used with switch 145-800	1
45	331-630	\$19.79	CABLE, starter pull	Bugeye	1
	331-710	\$19.79	CABLE, starter pull, replacement	Sprite MklII, Midget Mkl	1
46	131-555	\$12.99	VOLTAGE STABILIZER, negative ground	1275, 1500	1
47	141-750	\$8.49	FLASHER, turn signal, screw terminals	948 - 1098	1
	171-300	\$7.89	FLASHER, turn signal, spade terminals	1275 thru '67	1
48	141-748	\$14.99	FLASHER, turn signal (replacement)	1275 1968 thru 1500	1
	141-655	\$4.49	FLASHER, hazard (replacement)	1275, 1968-'71	1
	141-747	\$13.99	FLASHER, hazard, electronic repl.		1
	141-650	\$4.89	FLASHER, hazard		1275 from '72, 1500

No.	Part No.	Price (each)	Description	Application	Qty. Req.
-----	----------	--------------	-------------	-------------	-----------

### Horns

60	165-700*	\$49.99	HORN, Windtone, high note	Bugeye, option	1
	165-800*	\$49.99	HORN, Windtone, low note		
61	545-030	\$36.99	HORN, high note	1098 thru 1500 (option for earlier cars)	1
	545-020	\$36.99	HORN, low note		
62	263-745	NA	SLIP RING & HORN CONTACT		1
63	560-430	\$6.49	CONTACT, horn push	948	1
	263-750	\$4.69	CONTACT, horn push	1275 as fitted	1

\* Sprite Mkl-MkII and Midget Mkl standard fitment was single horns of types no longer available. Bugeyes used #60 as options, while later 948cc cars used the 1098-1500 type as options.

Generators are suitable for either negative or positive ground systems providing they are polarized to suit the particular electrical system immediately after fitting. Bolt generator to engine, do not connect the cables to the "D" and "F" terminals, but proceed as follows:

1. Determine which battery terminal is ground.
2. Temporarily connect a length of wire to the battery positive terminal for negative ground systems, or to the negative terminal for positive ground systems.
3. Flick the other end of the wire several times against terminal "F". This serves to repolarize the generator.
4. Remove temporary connection and connect the cables to the "D" and "F" terminals.

# Generator & Alternator

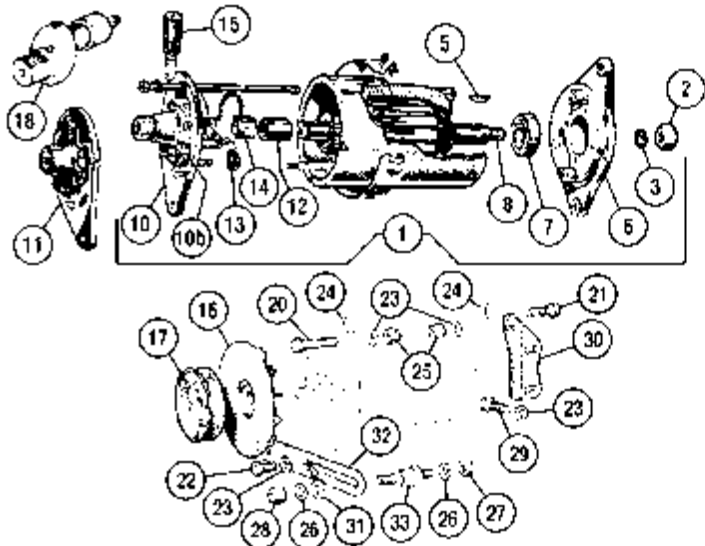

No.	Part No.	Price (each)	Description	Application	Qty. Req.
-----	----------	--------------	-------------	-------------	-----------

## Generator, 1958-'61 (948 cc engines)

1	140-300	\$239.99	GENERATOR, new		1
	140-310	\$199.99	GENERATOR, rebuilt		1
		\$300.00	CORE CHARGE for 140-310		
2	310-310	\$0.39	NUT, armature shaft		1
3	324-050	\$0.20	LOCKWASHER		1
5	327-030	\$0.39	KEY, armature shaft		1
6	147-300	NA	PLATE, drive end		1
7	125-100	\$8.79	BEARING, drive end		1
8	162-600	NA	ARMATURE		1
10	147-500	NA	PLATE, commutator end		1
10b	147-020	\$5.99	INSULATOR, terminal		1
12	147-600	\$6.89	BUSHING, rear		1
13	147-700	NA	SPRING SET, brushes		1
14	147-200	\$1.99	BRUSH SET		1
15	147-900	\$43.99	OILER		1
16	433-670	\$10.99	FAN		1
17	473-130	NA	PULLEY, stock type		1
	473-131	\$56.99	PULLEY, aluminum replacement		1
18	361-870	\$94.99	GEARBOX, tachometer drive		1

## Generator, 1962-'71

	140-200	\$119.99	GENERATOR, new, replacement	(no parts available)	1
	540-200	\$129.99	GENERATOR, Lucas, rebuilt		1
		\$250.00	CORE CHARGE for 540-200		
2	310-310	\$0.39	NUT		1
3	324-250	\$0.19	LOCKWASHER		1
5	327-030	\$0.39	WOODRUFF KEY, for pulley		1
6	147-310	NA	BRACKET, driving end		1
7	125-100	\$8.79	BEARING, driving end		1
8	162-900	\$79.99	ARMATURE		1
11	539-180	NA	BRACKET, commutator end		1
12	147-600	\$6.89	BUSH, commutator end		1
	697-020	\$0.69	OILER (internal, felt)		1
13	549-030	\$9.89	SPRING SET		1
14	147-250	\$1.99	BRUSH SET		1
16	433-670	\$10.99	FAN		1
17	473-130	NA	PULLEY, stock type		1
	473-131	\$56.99	PULLEY, aluminum replacement		1

## Generator Mountings

20	322-105	\$0.99	BOLT, front		1
21	191-915	\$1.39	BOLT, rear		1
22	322-510	\$0.29	BOLT		1
23	365-730	\$0.25	LOCKWASHER		5
24	365-720	\$0.29	WASHER, flat		2
25	310-290	\$0.69	NUT, nyloc		2
26	324-040	\$0.29	LOCKWASHER		2
27	310-050	\$0.59	NUT		1
28	310-240	\$0.39	NUT, nyloc		1
29	322-540	\$0.69	BOLT, bracket to block		2
30	460-310	\$28.99	BRACKET		1
31	324-860	\$0.19	WASHER, flat		1
32	460-330	\$8.79	LINK, adjusting (replacement)		1
33	460-320	\$6.89	PILLAR, adjusting link		1

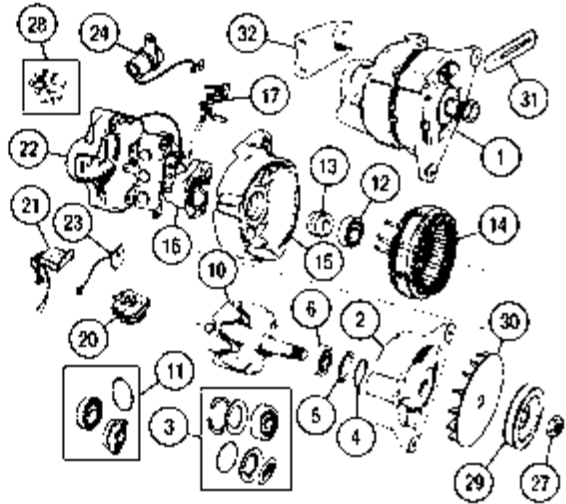

No.	Part No.	Price (each)	Description	Application	Qty. Req.
-----	----------	--------------	-------------	-------------	-----------

## Alternator, 1972-'80

1	130-102	\$97.99	ALTERNATOR, new		1
			Note: The alternator supplied is the replacement for all originally fitted alternators. Numbers listed in the application column are the Lucas numbers for the original units.		
2	NA		BRACKET, drive end		1
3	125-100	\$8.79	BEARING KIT, drive end		1
4	130-450	NA	O-RING		1
5	130-455	NA	CIRCLIP		1
6	125-100	\$8.79	BEARING, drive end		1
10	130-160	NA	ROTOR ASSEMBLY		1
11	130-180	NA	BEARING SET, slip ring end		1
12	NA		BEARING		1
13	130-215	\$3.39	SLIP RING		1
14	130-190	NA	STATOR		1
15	130-210	NA	BRACKET, slip ring end		1
16	130-230	NA	BRUSH HOUSING ASS'Y.		1
17	130-235	\$3.29	BRUSH SET		1
20	130-250	\$12.89	RECTIFIER	23716	1
	130-260	\$22.79	RECTIFIER	L23804, 23748	1
21	130-280	\$10.89	REGULATOR	23716	1
	130-290	\$29.99	REGULATOR	L23804, 23748	1
22	130-320	\$14.49	COVER		1
23	130-345	NA	SURGE PROTECTOR		1
24	130-350	NA	CAPACITOR		1
27	310-810	\$1.19	NUT		1
28	130-360	NA	SUNDRIES KIT		1
29	130-370	\$26.79	PULLEY	1275 engines	1
	539-090	\$17.99	PULLEY	1500 engines	1
30	130-400	\$24.99	FAN		1
31	460-330	\$8.79	LINK, adjusting	} 1275 engines	1
32	130-115	\$14.49	BRACKET, rear		1

MOSS

MOSS MOTORS, LTD.  
TOLL-FREE ORDERS

1-800-667-7872

# Starter / Gauges & Cables

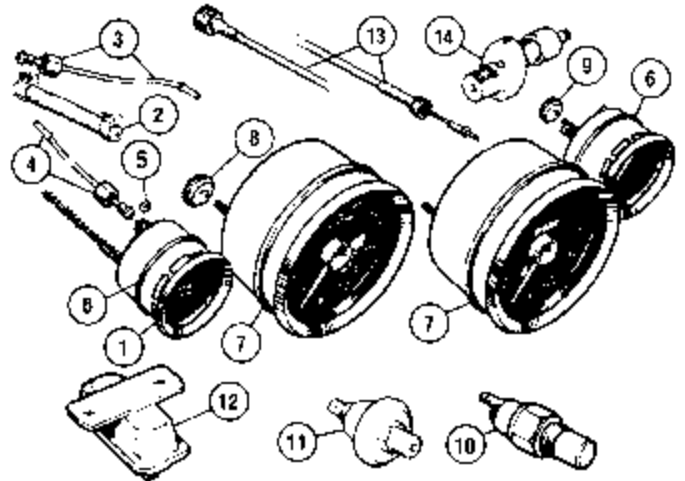
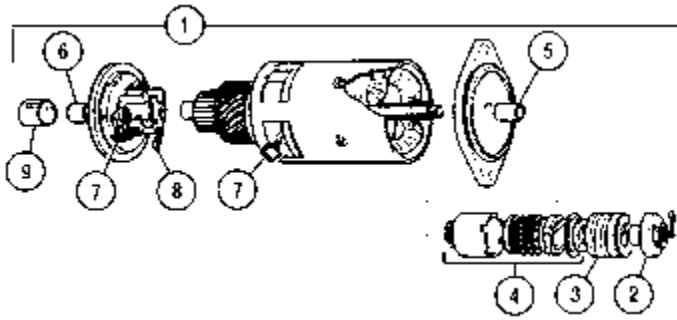

No.	Part No.	Price (each)	Description	Application	Qty. Req.
-----	----------	--------------	-------------	-------------	-----------

## Starter

1	140-400	\$96.99	STARTER, new reproduction		1
	541-540	\$139.99	STARTER, rebuilt, exchange		1
		\$250.00	CORE CHARGE FOR 541-540		
Note: Three different starters were originally fitted: Lucas #25022, 25079, and 25149. All are interchangeable with each other, but differ in some of their internal parts. The starter supplied replaces all three.					
2	150-500	\$25.99	NUT	25022	1
	549-625	NA	CLIP, used in place of nut	} 25079, 25149	1
		NA	CUP for clip		1
3	148-200	\$8.79	SPRING, main		1
4	148-800	\$36.99	PINION & BARREL* *inner sleeve not included		1
5	148-600	\$3.99	BUSH, driving end	25022	1
	148-610	\$1.99	BUSH, driving end	25079	1
	549-695	NA	BUSH SET (both bushes)	25149	1
6	148-500	\$1.39	BUSH, commutator end	25022	1
	131-325	\$0.79	BUSH, commutator end	25079	1
7	149-000	\$5.89	BRUSH SET (rectangular)	25022, 25079	1
	149-010	\$6.89	BRUSH SET (triangular)	25149	1
8	149-100	NA	SPRING SET, brushes	25022	1
	149-110	NA	SPRING SET, brushes	25079	1
9	149-800	NA	CAP, end shaft	25022	1

## Hi-Torque Starter

1958-74 (does not fit 1500)

Modern design and reliability make these starters ideal for the "daily driver". Even though they don't look like the originals, have integral solenoids, pre-engaged pinions, and gear reduction drive, they work very well indeed. We have tested these extensively on employee's cars, and heartily recommend them!  
(Does not fit Midget 1500)

**541-547 \$319.99**



Note: Moss does not stock gauges for Sprites and Midgets other than those listed and priced. Please inquire to:

MO-MA, 1321 2nd St. NW, Albuquerque, NM 87102 (505)766-6661, or

West Valley Instruments, 19314 Van Owen, Reseda, CA 91335 (818)758-9500

No.	Part No.	Price (each)	Description	Application	Qty. Req.
-----	----------	--------------	-------------	-------------	-----------

1	361-761	\$209.99	COMBINATION GAUGE (This replacement gauge is similar to all listed below, but not identical to any - a perfect gauge to use when the "correct" one is not available.)	replacement type	1	
	361-760	NA	COMBINATION GAUGE	AH Bugeye only	1	
	361-770	NA	COMBINATION GAUGE	AH MkII thru (c)24731	1	
	361-780	NA	COMBINATION GAUGE	{ MG MkI AH MkII from (c)24732	1	
	361-790	NA	COMBINATION GAUGE	{ MG MkII & III to (c)60440 AH MkIII & IV to (c)72033	1	
	361-800	NA	COMBINATION GAUGE	{ MG MkIII (c)60441 to 105500 AH MkIV (c)72034 on	1	
	361-810	\$189.99	COMBINATION GAUGE	MG MkIII (c)105501 to 154100	1	
	361-820	NA	COMBINATION GAUGE	{ MG 1500 thru 1977 (c)154101 to 200000	1	
2	361-765	\$16.99	HOSE, oil pressure, with clamps	} 948 through 1275	1	
3	435-445	\$15.79	PIPE ASS'Y., engine to hose		1	
4	435-446	\$28.99	PIPE ASS'Y., hose to gauge		1	
	435-475	\$22.99	PIPE ASS'Y. to gauge	1500	1	
5	435-516	\$0.24	WASHER, leather, oil pipe to gauge		1	
6	280-870	\$0.69	SEALING RING, 2" gauges		A/R	
7	280-890	\$1.19	SEALING RING, 4" gauges	USA thru 1967	2	
	280-895	\$0.89	SEALING RING, 3-1/2" gauges	USA from 1968 on	2	
8	361-035	\$2.99	NUT, speedo & tach retaining		4	
9	360-370	\$3.29	NUT, small gauge retaining		2	
10	071-241	\$7.29	TRANSMITTER, temp gauge	1500 from (c)200001-on	1	
11	131-585	\$6.29	SWITCH, oil pressure warn. light	1500 except CA	1	
	131-595	NA	SWITCH, oil pressure warn. light	1500 CA only	1	
12	131-555	\$12.99	VOLTAGE STABILIZER	1275 & 1500	1	
13	021-381	\$16.49	SPEEDOMETER CABLE, 54"	948, 1098, 1275 thru '671	1	
	331-300	\$14.79	SPEEDOMETER CABLE, 48"	1275 1968-on	1	
	331-590	\$15.99	CABLE, gearbox to interval counter	} (c)154101- 188000	1	
	115-405	\$14.29	CABLE, interval counter to speedo		1975 - '76 except CA	1
	331-600	NA	CABLE, gearbox to 1st interval counter	} (c)154101-180000	1	
	331-605	NA	CABLE, 1st to 2nd interval counter		1975 - '76 CA only	1
	115-405	\$14.29	CABLE, 2nd interval counter to speedo			1
	331-585	\$22.99	CABLE, gearbox to speedo	{ (c)1880001 - 200000 1977 except CA	1	
	331-590	\$15.99	CABLE, gearbox to interval counter	} (c)1880001 - 200000	1	
	115-405	\$14.29	CABLE, interval counter to speedo		1977 CA only	1
	331-590	\$15.99	CABLE, gearbox to interval counter	} (c)200001 - 212000	1	
	331-615	NA	CABLE, interval counter to speedo		1978 CA only	1
	331-595	\$23.89	CABLE, gearbox to speedo	{ (c)200001 on 1978 on except CA	1	
	331-595	\$23.89	CABLE, gearbox to speedo	{ (c)212001 on 1979 - '80 CA only	1	
14	732-000	\$13.89	TACHOMETER CABLE	} 948	1	
	361-870	\$94.99	GEARBOX, tach		1	

LOCAL & OVERSEAS: 805-681-3400

FAX: 805-692-2525 www.mossmotors.com

MOSS

# Dashboard

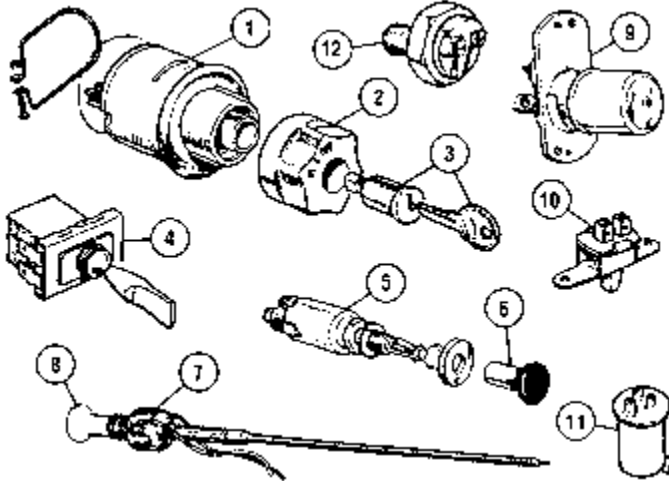
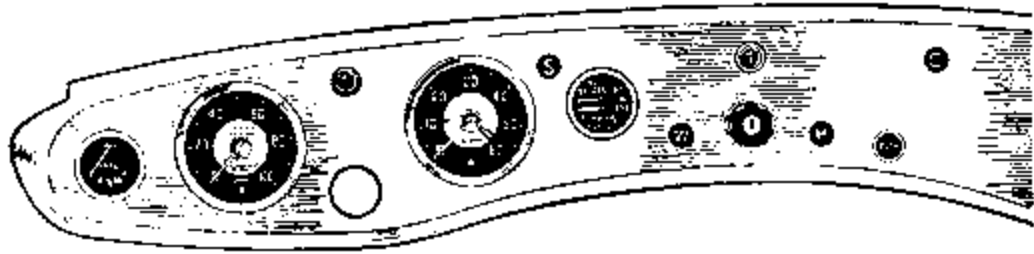

No.	Part No.	Price (each)	Description	Application	Qty. Req.
-----	----------	--------------	-------------	-------------	-----------

### Sprite MkI (Bugeye)

1	140-535	\$73.99	COMBINATION SWITCH. "Classic Gold" reproduction		1
2	140-515	\$13.49	KNOB, light & ignition switch		1
3	163-500	\$5.89	LOCK BARREL, with 2 keys		1
4	141-200	\$19.99	DIRECTIONAL SWITCH		1
5	162-100	\$11.89	WIPER SWITCH (supplied with plain knob)		1
6	331-075	\$10.89	KNOB, wiper switch		1
7	331-690	NA	HEATER CABLE & SWITCH (without knob)		1
8	331-085	\$11.59	KNOB, heater cable		1
9	140-900	\$29.89	SWITCH, high beam		1
10	140-520	\$44.89	SWITCH, panel lamp		1
11	141-750	\$8.49	FLASHER		1
12	141-700	\$7.99	SWITCH, brake light, screw connectors		1

Note: Starter switch and cable are listed on page 77.

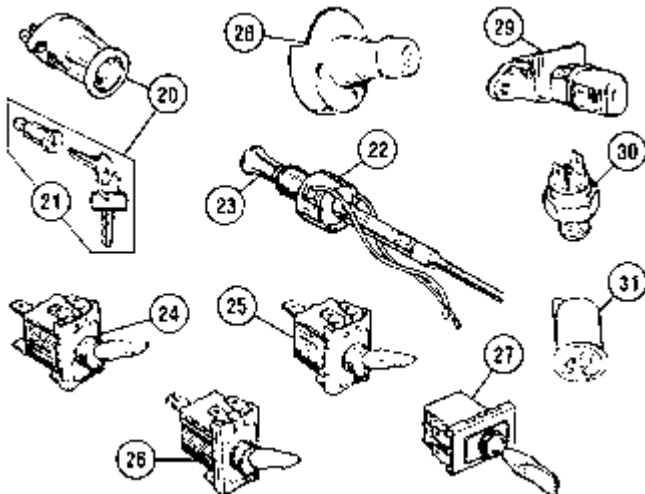
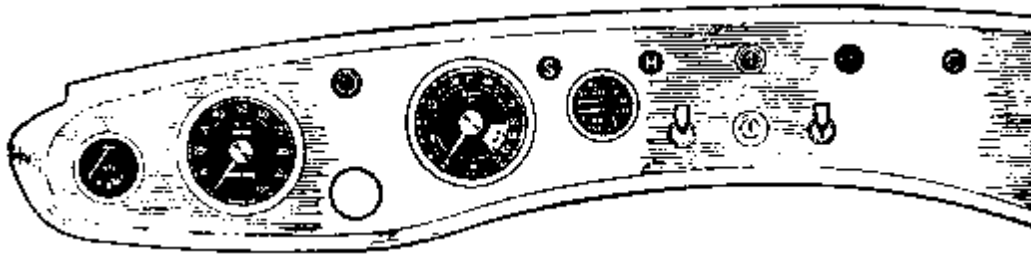

### Sprite MkII, Midget MkI

20	169-108	\$26.99	SWITCH, ignition		1
21	163-500	\$5.89	BARREL, with 2 keys		1
22	331-695	NA	HEATER SWITCH & CABLE (without knob)		1
23	331-085	\$11.59	KNOB, heater cable		1
24	141-530	\$15.99	SWITCH, panel lamps		1
25	141-530	\$15.99	WIPER SWITCH		1
26	NA		HEADLAMP SWITCH		1
27	141-200	\$19.99	SWITCH, turn signal		1
28	NA		SWITCH, high beam (Use #29, 542-130 as replacement)		1
29	542-130	\$12.49	SWITCH, high beam (replacement)		1
30	542-110	\$6.59	SWITCH, brake light		1
31	141-750	\$8.49	FLASHER UNIT screw connectors		1



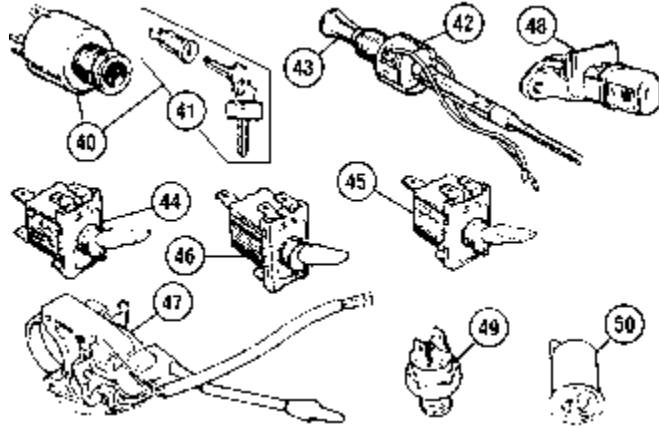
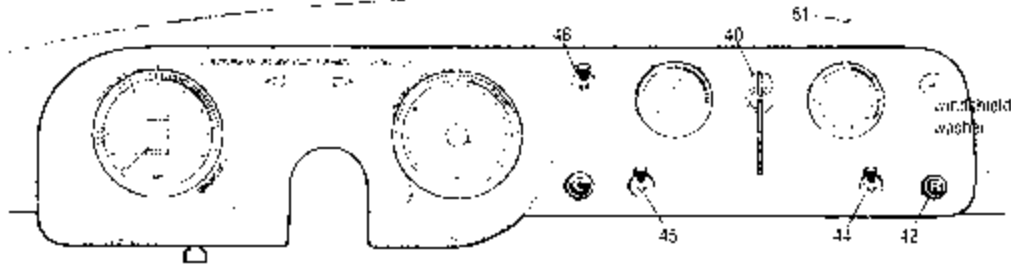

No.	Part No.	Price (each)	Description	Application	Qty. Req.
-----	----------	--------------	-------------	-------------	-----------

<b>Sprite MkIII-MkIV, Midget MkII-III thru 1967</b>					
40	542-070	\$14.99	SWITCH, ignition & starter	Sprite MkIII, Midget MkII	1
41	163-500	\$5.89	BARREL, with 2 keys		1
42	331-695	NA	HEATER SWITCH & CABLE (without knob)	thru 1965	1
	331-705	NA	HEATER SWITCH & CABLE (without knob)	1966 - '67	1
43	331-085	\$11.59	KNOB, heater cable		1
44	141-530	\$15.99	SWITCH, panel lamps		1
45	141-530	\$15.99	WIPER SWITCH		1
46	141-230	\$15.79	HEADLAMP SWITCH		1
47	141-770	\$34.99	SWITCH, turn signal		1
48	542-130	\$12.49	SWITCH, high beam		1
49	542-110	\$6.59	SWITCH, brake light		1
50	171-300	\$7.89	FLASHER UNIT	spade connectors	1
51	142-252	\$4.89	LAMP, oil filter warning (incl. bulb)	replacement type	1

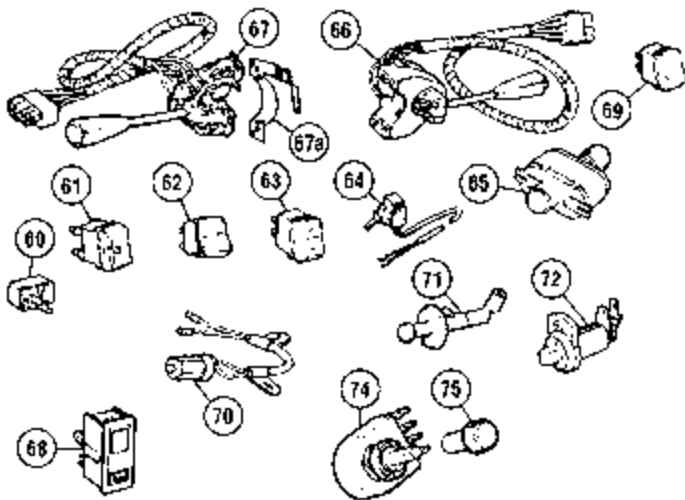
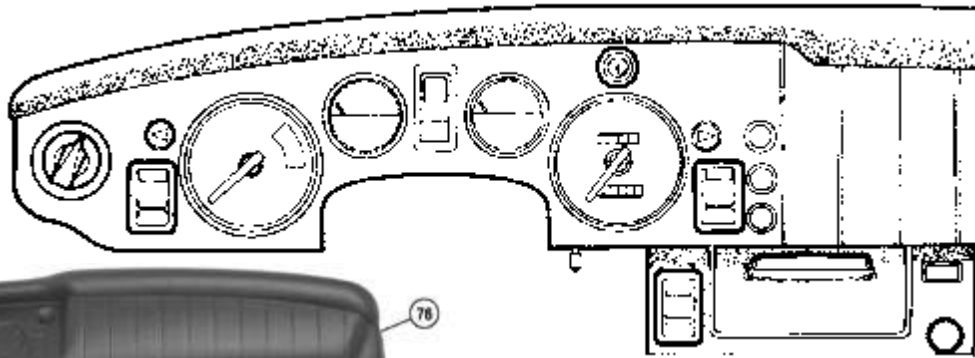

<b>1275 from 1968 &amp; 1500</b>					
60	141-748	\$14.99	FLASHER, turn signal	replacement, w/bracket	1
	141-655	\$4.49	FLASHER, hazard (replacement)	1275, 1968-'71	1
	141-650	\$4.89	FLASHER, hazard	1275 from '72, 1500	1
61	141-260	\$13.29	SWITCH, headlamp on/off	1275 to (c)123750	1
	141-275	\$11.99	SWITCH, headlamp on/off	1275 from (c)123751-1500	1
62	141-250	\$18.79	SWITCH, heater blower	1275	1
	141-270	\$13.79	SWITCH, heater blower	1500	1
63	140-540	\$29.99	SWITCH, hazard warning, replacement	1275, 1968-'72	1
	141-635	\$11.89	SWITCH, hazard warning	1275 from '73, all 1500	1
64	140-580	NA	SWITCH, panel lamp	1275	1
65	181-980	\$7.99	SWITCH, brake light	} 1275 & 1500	1
	310-070	\$0.39	JAM NUT for brake switch		1
66	141-825	\$67.79	SWITCH, wiper/washer	1275 thru '73	1
	141-845	\$53.49	SWITCH, wiper/washer	1275, 1500 '74-'77	1
	141-855	\$31.99	SWITCH, wiper/washer	1500 '78 - '79	1
67	141-810	\$54.99	SWITCH, directional, horn, dimmer	1275, 1968-'70	1
	141-830	\$53.49	SWITCH, directional, dimmer	1275, 1971 - '73	1
	141-840	\$31.99	SWITCH, directional, dimmer	1275, 1500, 1974-'77	1
	141-850	\$76.99	SWITCH, directional, horn, dimmer	1500, 1978 - '79	1
67a	141-804	\$26.99	CLAMP & HORN CONTACT	1275, 1500 1971-'77	1
68	141-280	\$17.99	LAMP, brake check & warning	} 1275	1
	170-160	\$0.99	BULB for brake check lamp no. 68		1
69	162-170	NA	SWITCH, fog, accessory		1
70	141-020	\$31.99	SWITCH, reverse lamp	1275	1
	542-410	\$10.99	SWITCH, reverse lamp	1500	1
71	131-620	\$13.79	SWITCH, trunk	1275	1
72	570-240	\$7.99	SWITCH, courtesy light	1971-on	1
	182-410	\$18.99	SWITCH, handbrake		1
74	146-000	\$35.99	RHEOSTAT, panel lamp (replacement)	} 1500	1
75	140-630	NA	KNOB		1
76	453-814	\$324.99	DASHBOARD COVER, padded	cars w/ manual choke	1
	453-817	\$324.99	DASHBOARD COVER, padded	cars w/ auto choke	1

Note: Steering column mounted ignition switches are listed on page 43.

**LOCAL & OVERSEAS: 805-681-3400**  
**FAX: 805-692-2525** [www.mossmotors.com](http://www.mossmotors.com)



# Interior Products

Restore your Sprite or MG Midget to original specifications with British made reproduction upholstery kits. With duplicated original patterns, vinyls, and even dielectrically welded seams where appropriate, your car will look factory new. Our seat and panel kits are complete and straightforward to install. (For seat kits see pages 80-81). The panel kits include sufficient vinyl to cover your dash panel and cockpit (except 1970-80 kits), new footwell boards, gearbox tunnel boards, inner sill boards, door pocket boards and rear quarter panels.

**Bugeye panel kits include plain vinyl for the inside of the doors instead of the original style ribbed rubber, which is not available. Also not available are the door pocket cardboards, metal brackets, and hardware.**

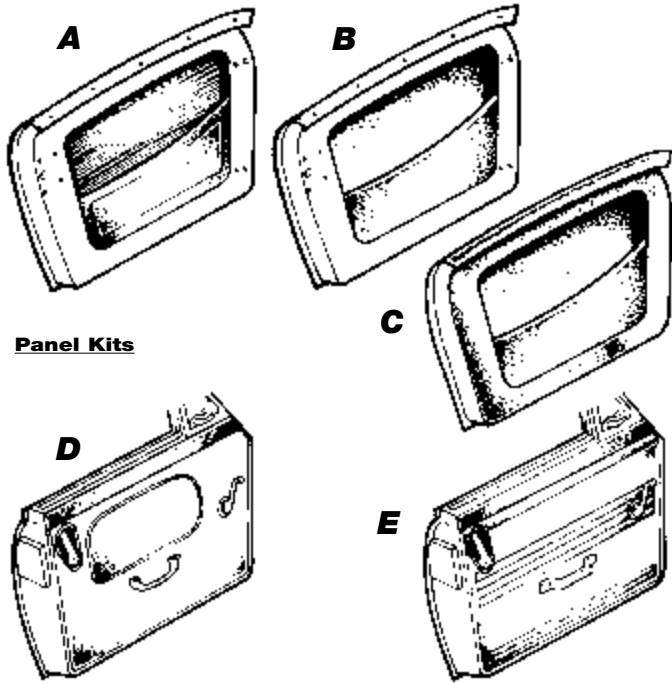

**Panel Kits**

Panel Kits	approx. model yr.	Black	Red	Blue	Navy	
Bugeye Sprite	1958-'60	645-500	645-510	645-520	645-530	\$329.99
948 Sprite MkII 948 Midget MkI	1961-'62	645-540	645-550	645-560	645-565	\$379.99
1098 Sprite HAN7 Midget GAN2	1963	645-620	645-630	-	-	\$419.99
1098 Sprite HAN8 Midget GAN3	1964-'66	645-570* * with white piping	645-580*	645-585* (Light Blue)	-	\$594.99

		Black with Black Piping	Black with White Piping	Red with White Piping	
1275 Sprite HAN9 1275 Midget GAN4	1967-'69	645-660	645-670	645-680	\$649.99
1275 Midget GAN5 1500 Midget GAN6	1970-'80	Black 645-700	Navy 645-710	Autumn Leaf 645-720	\$429.99

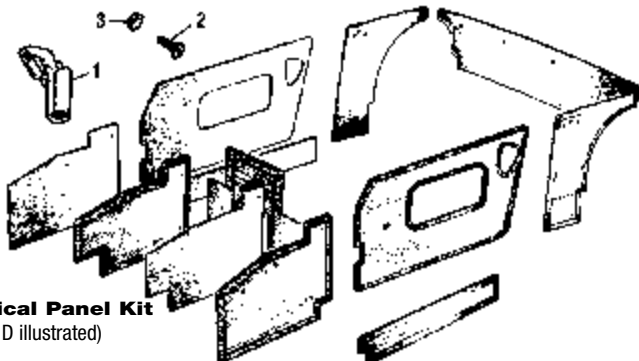

**Typical Panel Kit**  
(style D illustrated)

1	803-420	\$0.79	PANEL CLIP (replacement)	1966-'80	26
2	323-460	\$0.29	PANEL SCREW, chrome		A/R
	323-480	\$0.49	PANEL SCREW, black		A/R
	315-160	\$0.29	CUP WASHER, chrome		A/R
3	323-985	\$0.59	CUP WASHER, black		A/R



No.	Part No.	Price (each)	Description	Application	Qty. Req.
-----	----------	--------------	-------------	-------------	-----------

### Carpet Sets (cut pile)

Made in our very own upholstery shop (except for Autumn Leaf, which is English), these carpet kits are carefully patterned and cut for proper fit and easy installation. Each complete kit features the correct rubber heelmat, all necessary snaps and studs and bound edges where original. Note: Sprite MkI, MkII and Midget MkI had moulded rubber floor mats instead of floor carpet. These original type mats are not available. Our carpet sets include carpeting for these areas. For free samples of our carpet material, order sample card #878-915.

242-531	\$279.99	CARPET SET, black	} Sprite MKI (Bugeye) Floor and tunnel carpet only. May use Sprite MKII carpet for more complete coverage	1
242-532	\$279.99	CARPET SET, red		1
242-533	\$279.99	CARPET SET, blue		1
242-541	\$299.99	CARPET SET, black	} Sprite MKII, Midget MKI	1
242-542	\$299.99	CARPET SET, red		1
242-543	\$299.99	CARPET SET, blue		1
242-551	\$289.99	CARPET SET, black	} Sprite MKIII, Midget MKII	1
242-552	\$289.99	CARPET SET, red		1
242-553	\$274.95	CARPET SET, blue		1
242-560	\$319.99	CARPET SET, black	} Sprite MKIV, Midget MKIII	1
242-570	\$319.99	CARPET SET, red		1
242-580	\$319.99	CARPET SET, autumn leaf		1
242-563	NA	CARPET SET, blue		1
242-555	\$319.99	CARPET SET, navy		1
242-571	\$319.99	CARPET SET, black	} Midget 1500	1
242-572	\$319.99	CARPET SET, red		1
242-573	\$319.99	CARPET SET, autumn leaf		1

11	226-338	\$1.99	"VELTEX" CARPET RING ASS'Y.	A/R
12	226-800	\$0.89	SNAP & SCREW	A/R

### Rubber Floor Mat Sets

Protect your carpets from damage, while giving your interior added good looks with our heavy duty black ribbed rubber mats. Late mats are embossed with Midget or Sprite logo.



241-870	\$37.99	Sprite/Midget with side curtains (no logo) (Can be used with aluminum frame cover set #240-510)
241-880	\$37.99	Sprite, cars with roll-up windows
241-860	\$37.99	Midget, cars with roll-up windows

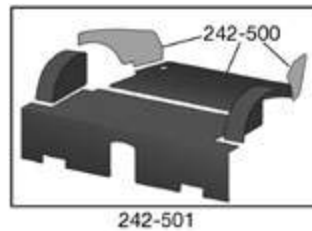

242-501

### Bugeye Rear Liner Sets

Dress up the dark chasm behind your seats with a liner set from Moss. "Original" set includes hardura trunk floor covering, two side panels, hardura wheel well covers, and hardura heelboard cover. Trunk kit includes trunk floor cover and side panels (use this when installing the Sprite MKII carpet set (which has also carpet heelboard & wheel well covers) in a Bugeye. Available in black only.

"Original" Set	242-501	\$199.99
Trunk Set	242-500	\$109.99

**MOSS** **MOSS MOTORS, LTD.** **TOLL-FREE ORDERS** **1-800-667-7872**

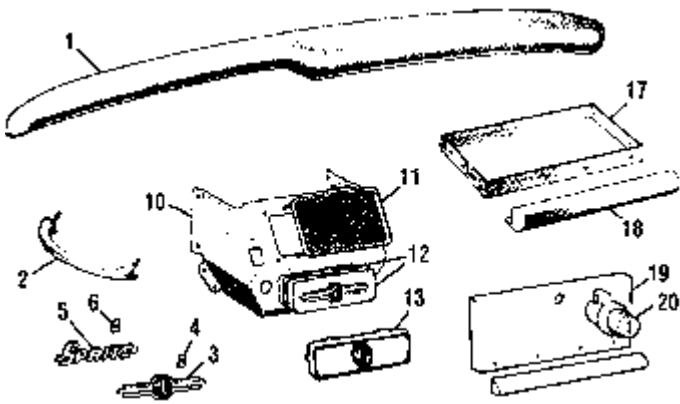

No.	Part No.	Price (each)	Description	Application	Qty. Req.
-----	----------	--------------	-------------	-------------	-----------

### Dashboard Fittings

1	453-950	\$62.99	DASH TOP COVER	1968-'80	1
Fully molded black ABS vinyl dash pad quickly and easily glues on the top of your existing dash, making even badly suncracked dashes look new again. Comes complete with adhesive and installation instructions.					
2	633-690	\$46.99	GRAB HANDLE, dashboard	Spite MKI, MKII	1
3	472-050	\$12.79	MG BADGE	} Midget (as fitted)	1
4	326-520	\$0.24	SPIRE NUT		2
5	470-615	\$24.89	SPRITE BADGE	} Sprite MKIII, MKIV	1
6	326-510	\$0.24	SPIRE NUT		2
10	453-810	\$229.99	RADIO CONSOLE	1968-80	1
11	233-835	\$109.99	SPEAKER SCREEN, chrome	1968-74	1
	233-855	NA	SPEAKER SCREEN, black	1975-80 (alt. to above)	1
12	472-078	\$22.89	RADIO BLANKING PLATE SET	1968-76 Midget	1
	472-079	\$38.99	RADIO BLANKING PLATE SET	1968-69 Sprite	1
13	472-035	\$9.79	RADIO BLANKING PLATE	1977-80 Midget	1
17	240-830	NA	PARCEL SHELF	1966-72	1
18	240-840	NA	PAD, parcel shelf		1
19		NA	GLOVE BOX DOOR	} 1972-80	1
20	234-400	\$74.99	GLOVE BOX LOCK with 2 keys		1

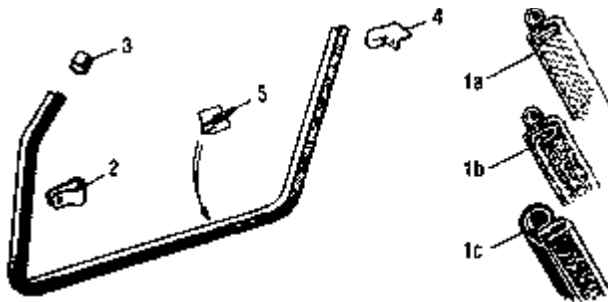

### Door Seal & Finishers

1a	249-800	\$21.99	DOOR SEAL, black woven fabric	} orig. type, 1958-'69	4	
	249-810	\$21.99	DOOR SEAL, red woven fabric		sold per yard	4
1b	249-609	\$16.99	DOOR SEAL, black velour	} alt. type, 1958-'69	4	
	249-695	\$21.99	DOOR SEAL, red velour		sold per yard	4
	249-857	\$21.99	DOOR SEAL, blue velour		4	
1c	259-907	\$5.99	DOOR SEAL, black vinyl	{ orig. type, 1970-'80	10	
				sold per foot		
2		NA	CLIP, door seal front	Sprite Mkl, II, Midget Mkl	2	
3	240-530	\$4.29	CLIP, door seal front end	} Sprite from MkIII (1275)	2	
4	240-545	\$10.79	FINISHER, L/H rear		} Midget from MkII (1275)-on	1
	240-540	\$10.79	FINISHER, R/H rear			1
5	249-795	\$0.59	CLIP, door seal to flange		20	

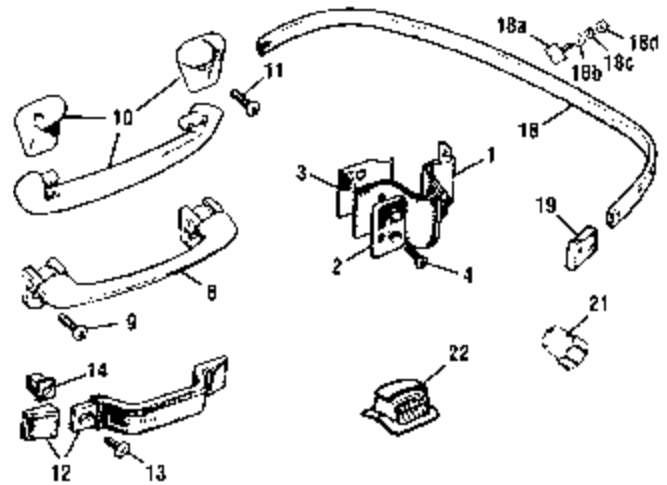

No.	Part No.	Price (each)	Description	Application	Qty. Req.
-----	----------	--------------	-------------	-------------	-----------

### Cockpit Fittings

1	240-675	\$22.99	CHECK STRAP, black		2	
	240-670	\$22.99	CHECK STRAP, red		2	
	240-680	\$22.99	CHECK STRAP, blue		2	
	240-685	\$22.99	CHECK STRAP, navy		2	
	240-690	\$22.99	CHECK STRAP, autumn leaf		2	
2	240-815	\$1.99	RETAINER, check strap		2	
3	240-805	\$3.99	BRACKET, check strap		2	
4	314-315	\$0.49	SCREW		4	
8	803-440	\$15.29	HANDLE, door pull	} Sprite to (c)72040	2	
9	402-485	\$0.59	SCREW, door pull		Midget to (c)60459	4
10	472-240	\$6.79	HANDLE, door pull	} Sprite from (c)72041	2	
11	402-485	\$0.59	SCREW, door pull		Midget (c)60460 to 105500	4
12	402-453	\$13.79	DOOR PULL, black	} Midget from (c)105501	2	
	402-450	NA	DOOR PULL, autumn leaf		2	
	402-455	\$14.79	DOOR PULL, yellow ochre		(1972-on)	2
	402-490	NA	DOOR PULL, navy		2	
13	314-285	\$0.39	SCREW, door pull		4	
14	402-710	NA	CAPTIVE NUT		4	
18	459-855	\$18.79	COCKPIT MOULDING, black vinyl	} 1967-'80	1	
18a	226-660	\$1.39	STUD PLATE, moulding		9	
18b	324-990	\$0.29	WASHER, plain		9	
18c	324-010	\$0.19	LOCKWASHER		9	
18d	310-040	\$0.19	NUT		9	
19	240-560	\$10.79	END CAP, chrome R/H		1	
	240-565	\$10.79	END CAP, chrome L/H		1	
21	402-550	\$3.09	DOME NUT, seat belt mounting as fitted		4	
22	241-015	NA	ASHTRAY ASSEMBLY		1	

# Seats

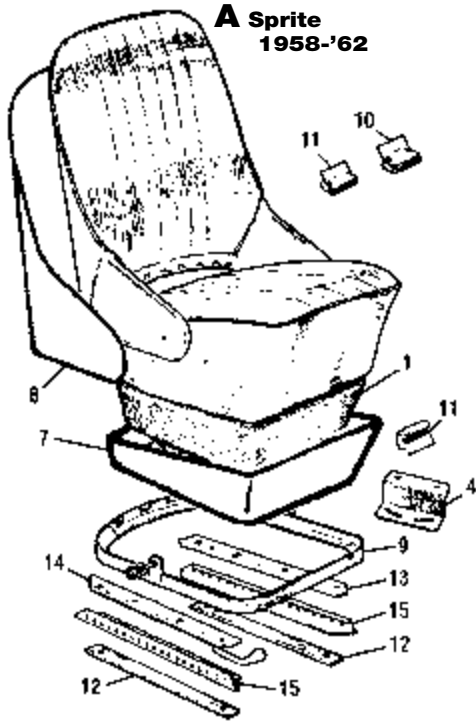

**A Sprite**  
1958-'62

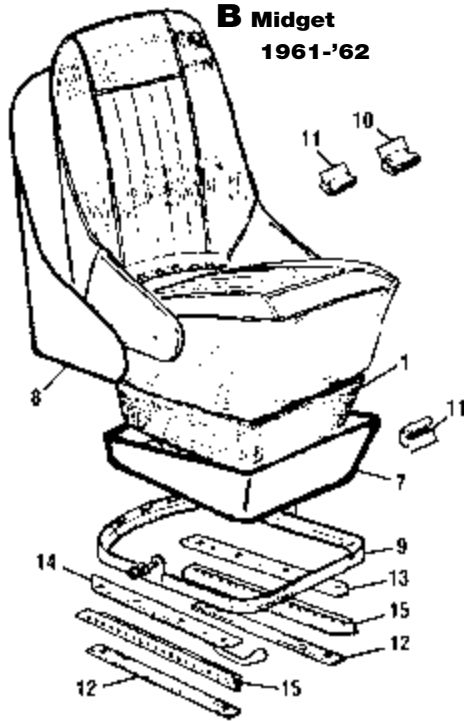

**B Midget**  
1961-'62

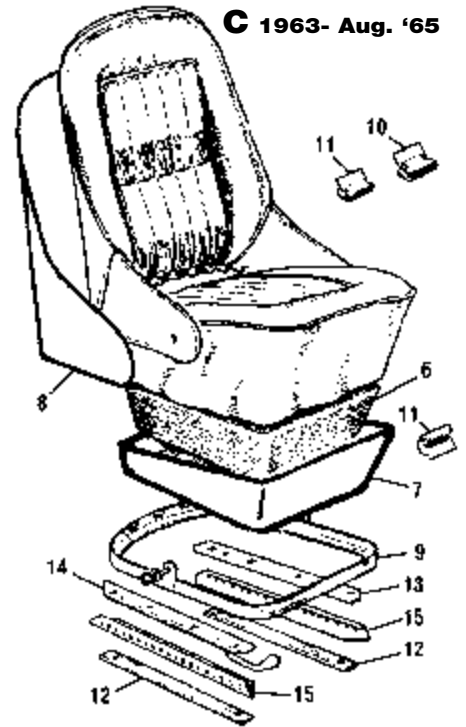

**C 1963- Aug. '65**

## Vinyl Seat Kits

	Black with White Piping	Red with White Piping	Blue with Lt.Blue Piping	
<b>A Bugeye Sprite, 948 Sprite Mk II</b> to HAN7-24731				
	640-777	640-778	640-779 (Blue)	\$429.99
			640-776 (Navy Blue)	\$429.99
<b>B 948 Midget Mk I</b> to GAN1-16183				
	640-700	640-702	640-706 (Blue)	\$429.99
<b>C 1098 Sprite Mk II &amp; Mk III</b> from HAN7-24732 to HAN8-55372 (approx.)				
<b>Midget Mk I &amp; Mk II</b> from GAN2-16184 to GAN3-42900 (approx.)				
	640-720	640-722	640-724 (Navy/Navy)	\$429.99
			640-725 (Blue/Wht)	\$429.99
<b>D 1098 Sprite Mk III &amp; 1275 Mk IV</b> from (approx.) HAN8-55373 to HAN9-77590				
<b>Midget Mk II</b> from approx. GAN3-42900, <b>Midget Mk III</b> to GAN4-66225				
	640-935	640-936	640-934 (Blue/White)	\$379.99
<b>E 1275 Sprite Mk IV*</b> from HAN9-77591 to HAN9-85286 (*Headrest covers not included)				
<b>1275 Midget Mk III*</b> from GAN4-66226 to GAN4-74885				
	<b>Black</b>			
	640-945* (fixed back - USA)			\$474.99
	640-950* (reclining back - not USA)			\$499.99
<b>F 1275 Sprite Mk IV*</b> from HAN10-85287 on (*Headrest covers not included)				
<b>1275 Midget Mk III &amp; Midget 1500*</b> from GAN5-74886 thru 1500				
	<b>Black</b>	<b>Autumn Leaf</b>	<b>Navy</b>	
	640-960	640-980	640-930	\$489.99
Headrest Cover ('70-'76)	640-200	640-225	640-210	\$51.99
Headrest Cover ('77-'80)	640-335	640-345	NA	\$58.99

## Leather Seat Kits

	Black / White	Red / White	
<b>A Bugeye Sprite, 948 Sprite Mk II</b> to HAN7-24731	640-781	640-782	\$699.99
<b>B 948 Midget Mk I</b> to GAN1-16183	640-710	640-712	\$699.99
<b>C 1098 Sprite Mk II &amp; Mk III</b> from HAN7-24732 to HAN8-55372 (approx.)			
<b>Midget Mk I &amp; Mk II</b> from GAN2-16184 to GAN3-42900 (approx.)	640-740	640-742	\$699.99
<b>D 1098 Sprite Mk III &amp; 1275 Mk IV</b> from (approx.) HAN8-55373 to HAN9-77590			
<b>Midget Mk II</b> from approx. GAN3-42900, <b>Midget Mk III</b> to GAN4-66225	640-965	640-966	\$599.99
<b>E 1275 Sprite Mk IV*</b> from HAN9-77591 to HAN9-85286 (*Headrest covers not included)			
<b>1275 Midget Mk III*</b> from GAN4-66226 to GAN4-74885			
	<b>Black</b>		
	640-800	(fixed back)	\$1049.00
<b>F 1275 Sprite Mk IV*</b> from HAN10-85287 on (*Headrest covers not included)			
<b>1275 Midget Mk III &amp; Midget 1500*</b> from GAN5-74886 thru 1500			
(not original pleat pattern - has vertical pleats)			
	<b>Black</b>	<b>Autumn Leaf</b>	
	640-805	640-810	\$1149.00



**Moss Seat Kits** All front seat kits include covers for both front seats. No matter what else you do to your car, one thing which everyone notices is the condition of the seats. Put your seats in tip top condition with a "just as it came from the factory" vinyl kit, or upgrade your car's interior with one of our luxurious leather kits. (Don't forget pads and cushions - we stock a complete selection to properly fill out your new covers, and make your "new" seats as comfortable as can be.) All of the Sprite & Midget seat kits we sell are made of the very best materials, patterned exactly like the originals. **As original from the factory, our leather seat kits have only the seating/wearing surfaces in leather, with the non-wearing surfaces in matching vinyl.**

MOSS

MOSS MOTORS, LTD.  
TOLL-FREE ORDERS

1-800-667-7872

## D Aug. 1965-'68

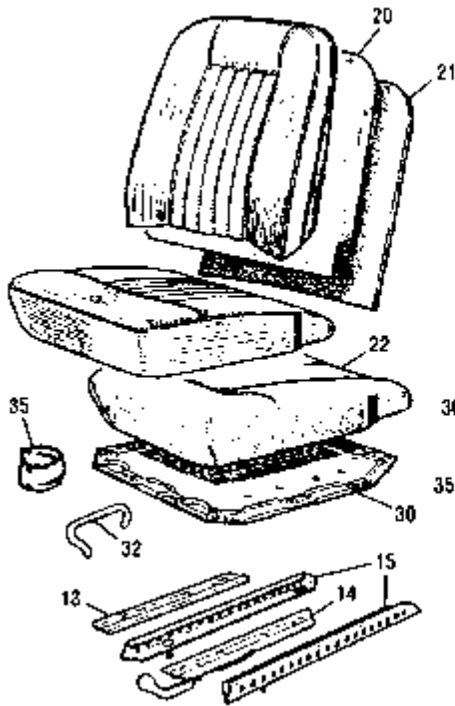

## E 1969

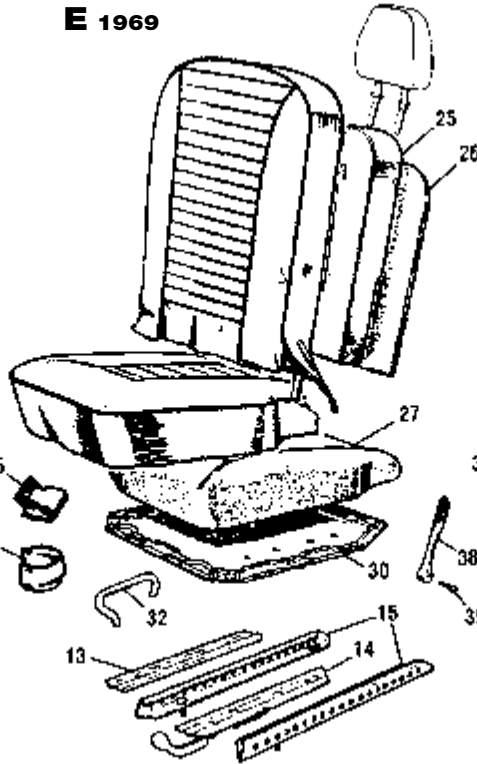

## F Midget 1970-'80

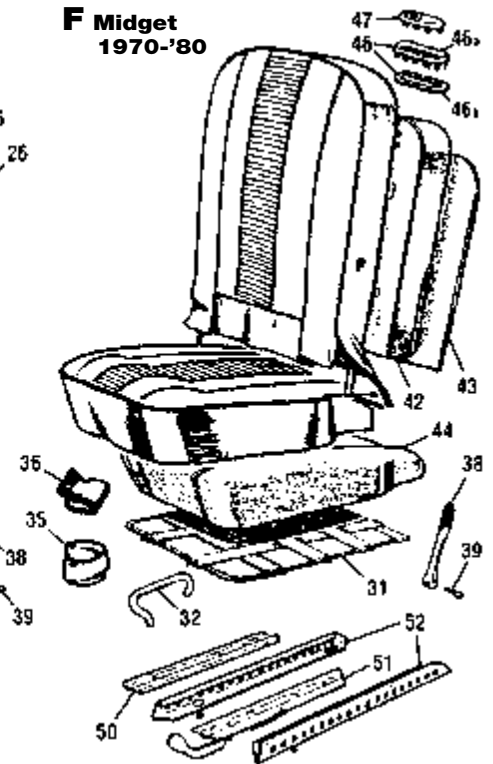

No.	Part No.	Price (each)	Description	Application	Qty. Req.
-----	----------	--------------	-------------	-------------	-----------

### Seat Components (see detailed car number applications on facing page)

1	640-468	\$194.99	CUSHION & PADDING KIT (foam cushion, plus padding for seat back)	} seats "A" & "B"	2
4	640-630	\$28.99	BRACKET, seat mounting *	seat "A"*	4
*These brackets were used instead of seat slides on Bugeye passenger's seat. 948cc Sprite MkII (H-AN6) could be had with the passenger's seat mounted on either these brackets or on slides.					
6	640-478	\$279.99	FOAM CUSHION & PADDING KIT (foam cushion, plus padding for seat back)	} seat "C"	2
7	640-570	\$239.99	BASE, steel	} seats "A", "B", "C"	2
8	640-575	\$279.99	BACK, steel		2
9	640-640	\$199.99	FRAME		2
10	326-185	\$0.69	CLIP, seat back (large)		20
11	326-155	\$0.24	CLIP, back & cushion covers (small)		56
12	640-605	\$13.99	PACKING STRIP, wood	} seats "A", "B", "C"	4
13	640-600	NA	RUNNER, upper, plain	} seats "A" thru "E"	2
14	640-585	NA	RUNNER w/lever, R/H		1
	640-595	NA	RUNNER w/lever, L/H		1
15	640-590	\$29.99	RAIL, lower		4
20	641-960	\$49.99	BACK FOAM	} seat "D"	2
21	640-545	\$20.49	BACK BOARD		2
22	640-530	\$104.99	CUSHION FOAM		2
25	640-550	\$99.99	BACK FOAM	} seat "E"	2
26	640-505	NA	BACK BOARD, adjustable seatback		2
	640-635	NA	BACK BOARD, non-adj. seatback		2
27	640-560	\$99.99	CUSHION FOAM		2
30	281-827	\$21.99	DIAPHRAGM, rubber	seats "D", "E"	2
31	281-858	\$29.99	DIAPHRAGM, web	seat "F"	2
32	325-185	\$0.59	HOOK, diaphragm	} seats "D", "E", "F"	20
35	226-645	\$0.49	CLIP, cushion cover		A/R
36	326-185	\$0.69	CLIP, back cover	} seats "E", "F"	6
38	409-020	\$17.99	HANDLE, seat back adjusting		2
39	323-205	\$1.49	SCREW, handle		2

No.	Part No.	Price (each)	Description	Application	Qty. Req.
-----	----------	--------------	-------------	-------------	-----------

42	640-500	\$89.99	BACK FOAM, R/H	} seat "F"	1
	640-510	\$89.99	BACK FOAM, L/H		1
43	640-515	\$17.49	BACK BOARD		2
44	640-520	\$44.99	CUSHION FOAM		2
46	409-108*	\$3.69	RING ASS'Y, headrest aperture		2
46a	409-100	NA	FINISHING RING	2	
46b	409-105	\$0.99	EYELET	2	
47	227-170	\$2.99	PLUG, black (when headrests out)	2	
*installed on seat kits					
50	640-600	NA	RUNNER, upper, plain	} seat "F", 1970-'71 to approx. (c)105500	2
51	640-585	NA	RUNNER w/lever, R/H		1
	640-595	NA	RUNNER w/lever, L/H		1
52	640-610	\$12.99	RAIL, lower, R/H of ea. seat		2
	640-620	\$12.99	RAIL, lower, L/H of ea. seat	2	
	NA	NA	RUNNER, upper, plain	} seat "F", 1972-'80 from approx. (c)105501	2
	NA	NA	RUNNER w/lever, R/H		1
	NA	NA	RUNNER w/lever, L/H		1
640-615	\$12.99	RAIL, lower, R/H of ea. seat	2		
640-625	\$12.99	RAIL, lower, L/H of ea. seat	2		



### Midget Headrests

Beautiful reproductions of an often missing or weather-ruined upholstery part. (Sorry - twin-post headrests for 1969 cars are not available.) Sold individually.

	Black	Navy	Ochre	Autumn Leaf	Champagne	
1970-'72 "Eared type" perforated.						
649-100	NA	NA	649-130	NA	\$109.99	
1972-'76 "Eared type" non-perforated						
649-140	649-150	NA	649-170	NA	\$109.99	
1977-'80 "Teardrop type" non-perforated						
641-605	641-615	NA	641-635	NA	\$104.99	

# Tonneau Covers



## Tonneau Covers

Tonneau covers are the time tested method of protecting your car's interior. Our tonneau covers incorporate the finest materials and workmanship and are supplied complete with hardware (fasteners on car body not included).

**Stayfast** is an acrylic canvas which is soft and flexible over a wide temperature range, yet is waterproof, and highly resistant to sagging, billowing, shrinking and fading. (These are made to order, so please allow 6 to 10 weeks for delivery.)



No.	Part No.	Price (each)	Description	Application	Qty. Req.
-----	----------	--------------	-------------	-------------	-----------

### Tonneau Cover, Sprite MK1 ("Bugeye")

1	241-270	\$299.99	TONNEAU COVER, black vinyl		1
	241-271	\$686.99	TONNEAU COVER, black Stayfast		1
	241-272	\$687.99	TONNEAU COVER, tan Stayfast		1
2	226-308	\$1.09	FASTENER, "Lift the Dot"		3
3	227-600	\$10.89	FASTENER, "Tenax" (genuine "Tenax" brand)		4
4	227-408	\$0.89	EYELET		2

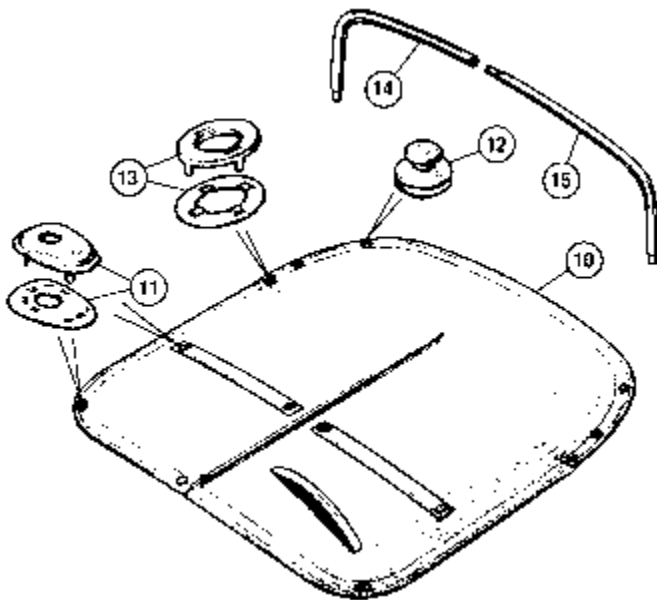

### Tonneau Cover, Sprite MKII, Midget MKI (1961-'64)

10	241-280	\$329.99	TONNEAU COVER, black vinyl		1
	241-281	\$646.99	TONNEAU COVER, black Stayfast		1
	241-282	\$646.99	TONNEAU COVER, tan Stayfast		1
11	226-308	\$1.09	FASTENER, "Lift the Dot"		7
12	227-600	\$11.99	FASTENER, "Tenax" (genuine "Tenax" brand)		4
13	227-408	\$0.89	EYELET		2
14	453-605	\$62.99	TONNEAU BAR, R/H		1
15	453-635	\$62.99	TONNEAU BAR, L/H		1

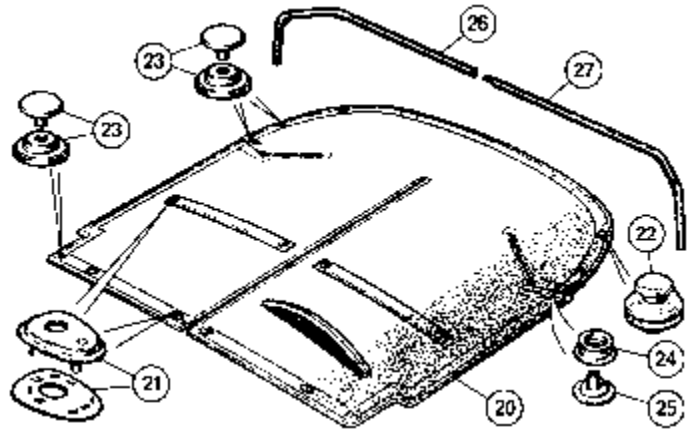

### Tonneau Cover, Sprite MKIII, Midget MKII (1964-'66)

20	241-285	\$365.99	TONNEAU COVER, black		1
	241-286	\$644.99	TONNEAU COVER, black Stayfast		1
	241-287	\$644.99	TONNEAU COVER, tan Stayfast		1
21	226-308	\$1.09	FASTENER, "Lift the Dot"		8
22	227-600	\$10.89	FASTENER, "Tenax" (genuine "Tenax" brand)		2
23	227-108	\$0.49	SNAP ASS'Y., female		4
24	226-720	\$0.29	SNAP, male		2
25	226-605	\$0.19	SNAP BASE		2
26	453-910	\$29.99	TONNEAU BAR, R/H		1
27	453-915	\$29.99	TONNEAU BAR, L/H		1

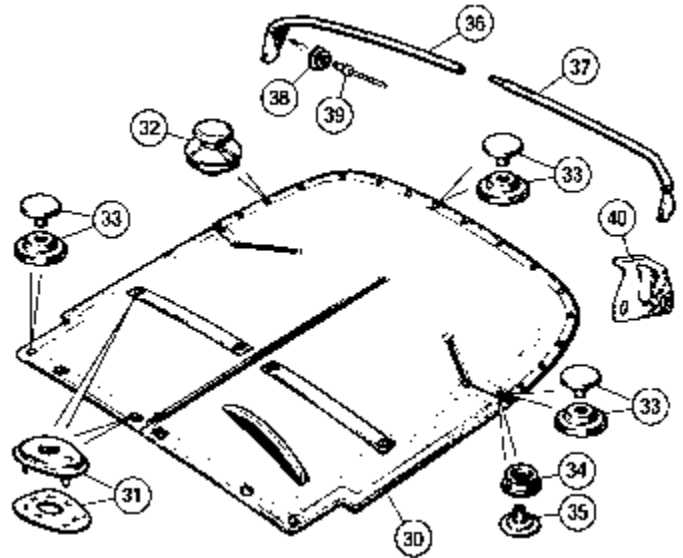

### Tonneau Cover, Sprite MKIV, Midget MKIII (1967-'68)

30	241-290	\$356.99	TONNEAU COVER, black vinyl		1
	241-291	\$699.99	TONNEAU COVER, black Stayfast		1
	241-292	\$699.99	TONNEAU COVER, tan Stayfast		1
31	226-308	\$1.09	FASTENER, "Lift the Dot"		8
32	227-600	\$10.89	FASTENER, "Tenax" (genuine "Tenax" brand)		8
33	227-108	\$0.49	SNAP ASS'Y., female		11
34	226-720	\$0.29	SNAP, male		2
35	226-605	\$0.19	SNAP BASE		2
36	453-920	\$64.99	TONNEAU BAR, R/H		1
37	453-925	\$64.99	TONNEAU BAR, L/H		1
38	226-720	\$0.29	SNAP, male		2
39	325-287	\$0.19	RIVET		2
40	402-565	\$32.49	BRACKET, tonneau bar		2

MOSS

MOSS MOTORS, LTD.  
TOLL-FREE ORDERS

1-800-667-7872

# Tonneau Covers

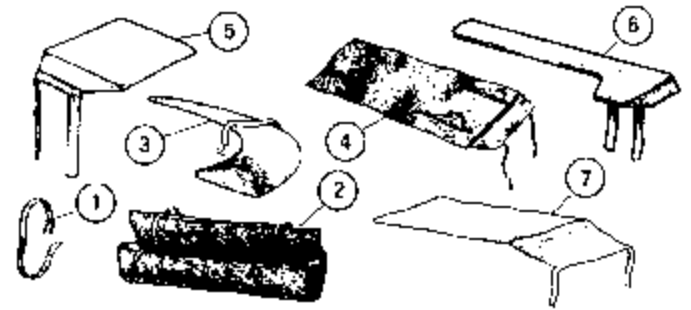
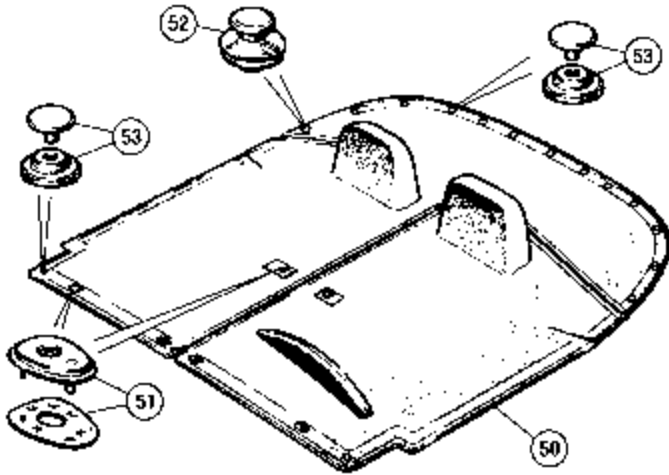

## Stowage Bags

1	385-955	\$10.99	STRAP, top stowage, replacement	1958-66	2
2	242-575	NA	TOP STOWAGE BAG	Sprite MkII, Midget Mkl	1
3	242-595	NA	TOP FRAME STOWAGE BAG	Sprite MkII-III, Midget Mkl-II	1
4	242-585	\$109.99	SIDE CURTAIN STOWAGE BAG		1
5	242-605	\$48.99	TONNEAU COVER STOWAGE BAG		1
6	242-565	\$42.99	TONNEAU BAR STOWAGE BAG	1967-68	1
7	242-590	NA	TOP COVER STOWAGE BAG	1967-80	1

No.	Part No.	Price (each)	Description	Application	Qty. Req.
-----	----------	--------------	-------------	-------------	-----------

## Tonneau Cover, 1969-on

50	241-300	\$365.99	TONNEAU COVER, black vinyl		1
	241-301	\$709.99	TONNEAU COVER, black Stayfast		1
	241-302	\$709.99	TONNEAU COVER, tan Stayfast		1
51	226-308	\$1.09	FASTENER, "Lift the Dot"		6
52	227-600	\$10.89	FASTENER, "Tenax" (genuine "Tenax" brand)		6
53	227-108	\$0.49	SNAP ASS'Y., female		9

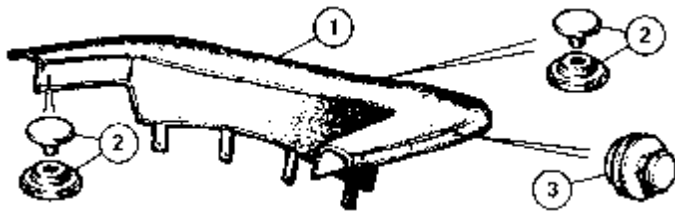

## Top Cover

1	241-525	\$279.99	TOP COVER, black	1969-'80	1
2	227-108	\$0.49	SNAP ASS'Y., female		9
3	227-600	\$10.89	TENAX FASTENER (genuine "Tenax" brand)		6

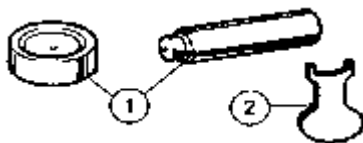

1	386-980	\$5.79	SNAP FASTENING TOOL		1
2	387-055	\$1.49	FITTING KEY, Tenax fastener		1

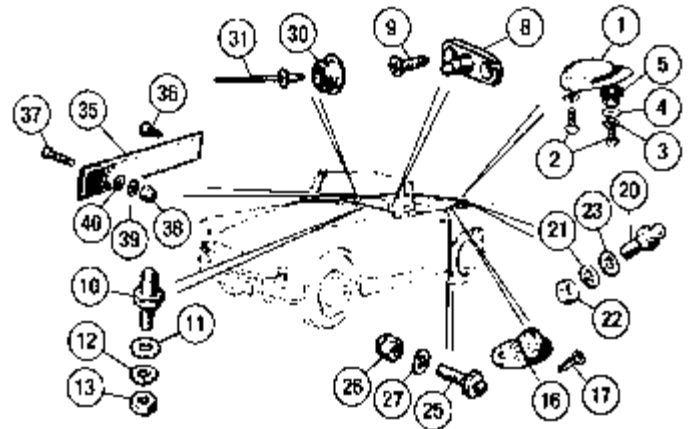

## Body Fittings, Tonneau Covers

1	470-747	\$4.79	RETAINER, top & tonneau cover		2
2	323-455	\$0.49	SCREW	all through 1966	4
3	324-010	\$0.19	LOCKWASHER		4
4	324-990	\$0.29	WASHER, plain		2
5	470-757	\$1.39	WASHER, cup		2
8	226-630	\$3.79	STUD, "Lift-the-Dot", rear heelboard	all except Bugeye	4
9	323-460	\$0.29	SCREW		8
10	226-600	\$1.99	STUD, "Lift-the-Dot", dash top	thru 1963 use 3 from 1964 use 4	3/4
11	435-515	\$0.49	WASHER, leather		3/4
12	324-010	\$0.19	LOCKWASHER		3/4
13	310-040	\$0.19	NUT		3/4
16	227-500	\$1.29	TURNBUCKLE	thru 1963	2
17	323-460	\$0.29	SCREW		2
20	227-700	\$2.19	STUD, "Tenax" (3/8" long stud)	most applications	A/R
21	324-010	\$0.19	LOCKWASHER		A/R
22	311-030	\$0.19	NUT		A/R
23	435-515	\$0.49	WASHER, leather	thru 1968	A/R
	324-012	\$0.39	WASHER, chrome		1969-on
25	227-010	\$2.19	STUD, "Tenax" (5/8" long stud)		2
26	311-010	\$1.89	DOME NUT, chrome	1964-'68	2
27	324-010	\$0.19	LOCKWASHER		2
30	226-720	\$0.29	SNAP, male	1964-80	A/R
31	325-287	\$0.19	RIVET for snap		A/R
35	242-215	\$9.79	VELCRO STRIP		2
36	323-460	\$0.29	SCREW, rear		2
37	312-235	\$1.39	SCREW, front	1969-'80	2
38	311-350	\$1.69	DOME NUT		2
39	315-070	\$0.24	LOCKWASHER		2
40	315-075	\$0.19	WASHER		2

# Top Fittings / Sidecurtains

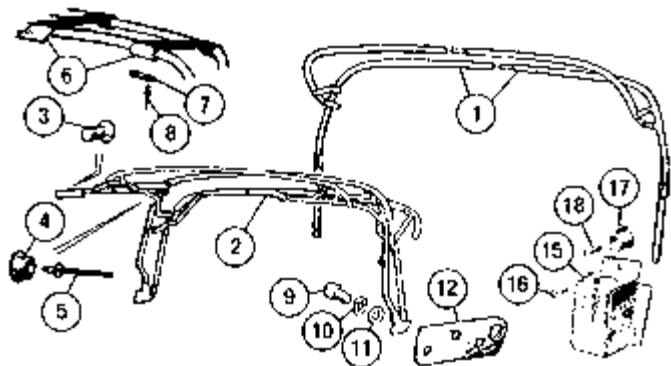

No.	Part No.	Price (each)	Description	Application	Qty. Req.
-----	----------	--------------	-------------	-------------	-----------

## Top Frames

	400-630	\$409.99	TOP FRAME ASSY.	Sprite MKI (Bugeye)	1
1	400-648	\$374.99	TOP FRAME ASSY. (2 piece)	Sprite MKII, Midget Mkl	1
	400-658	\$399.99	TOP FRAME ASSY. (2-piece)	Sprite MkIII, Midget MkII	1
2	400-680	\$429.99	TOP FRAME ASSY. (permanent mount)	1967-'80	1
3	323-255	\$0.69	SCREW, frame to header rail		6
4	226-720	\$0.29	MALE SNAP		4
5	325-287	\$0.19	RIVET for snaps		4
6	NA		WEBBING KIT, top frame		1
7	402-545	NA	PLATE, securing webbing		6
8	326-285	\$1.29	RIVET for plates		12
9	322-290	\$0.89	BOLT, top frame to body, short		2
	320-695	\$0.69	BOLT, top frame to body, long		4
10	365-730	\$0.25	LOCKWASHER		6
11	365-720	\$0.29	WASHER, plain		6
12	402-595	\$1.79	PACKING PIECE, top frame to body		2
15	402-555	\$23.99	BRACKET, top frame stowage	Bugeye only	2
16	314-070	\$0.29	SCREW		6
17	NA		BUFFER		2
18	314-045	\$0.29	SCREW for buffer		2



## Side Curtains

Fit your Sprite or Midget with a set of our factory style side curtains, complete with sealing strips, brackets and screws. Just like the originals, these side curtains look great while keeping out the wind, the cold and the rain.

259-678	\$559.99	Side Curtain Set, Complete	1
259-675	\$34.99	Bracket Set with nuts & bolts	1
282-455	\$18.89	Outer Seal, L/H	1
282-465	\$18.89	Outer Seal, R/H	1

See page 65 for sidecurtain mounting screws.

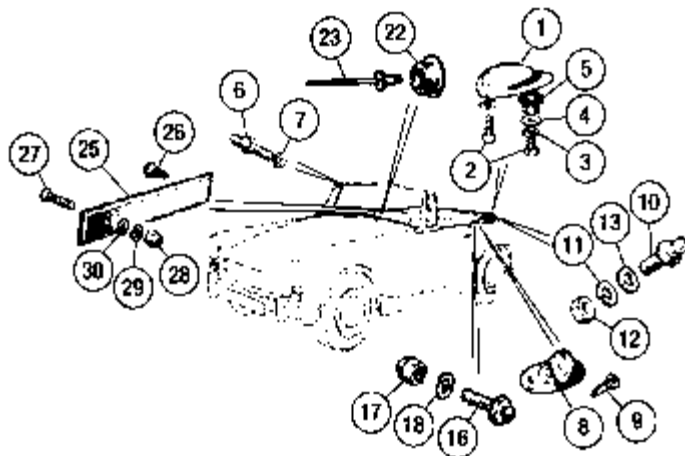

No.	Part No.	Price (each)	Description	Application	Qty. Req.
-----	----------	--------------	-------------	-------------	-----------

## Body Fittings, Tops

1	470-747	\$4.79	RETAINER, top & tonneau cover	all through 1966	2
2	323-455	\$0.49	SCREW		4
3	324-010	\$0.19	LOCKWASHER		4
4	324-990	\$0.29	WASHER, plain		2
5	470-757	\$1.39	WASHER, cup		2
6	NA		STUD, Lift-the-Dot	Bugeye thru (c)5476	9
	226-600	\$1.99	STUD, Lift-the-Dot	Bugeye from (c)5477, Sprite MkII, Midget Mkl	2
7	310-040	\$0.19	NUT		2
8	227-500	\$1.29	TURNBUCKLE	thru 1963	2
9	323-600	\$0.39	SCREW		2
10	227-700	\$2.19	STUD, "Tenax" (3/8" long stud)	most applications	A/R
11	324-010	\$0.19	LOCKWASHER		A/R
12	311-030	\$0.19	NUT		A/R
	435-515	\$0.49	WASHER, leather	thru 1968	A/R
	324-012	\$0.39	WASHER, chrome	1969-on	6
16	227-010	\$2.19	STUD, "Tenax" (5/8" long stud)	1964-'68	2
17	311-010	\$1.89	DOME NUT, chrome		2
18	324-010	\$0.19	LOCKWASHER		2
22	226-720	\$0.29	SNAP, male	1964-80	A/R
23	325-287	\$0.19	RIVET for snap		A/R
25	242-215	\$9.79	VELCRO STRIP	1969-'80	2
26	323-460	\$0.29	SCREW, rear		2
27	312-235	\$1.39	SCREW, front		2
28	311-350	\$1.69	DOME NUT		2
29	315-070	\$0.24	LOCKWASHER		2
30	315-075	\$0.19	WASHER		2





Robbins high quality replacement tops duplicate the original tops in almost all respects. Stayfast is an acrylic canvas which is soft and flexible over a wide temperature range, yet is waterproof, and highly resistant to sagging, billowing, shrinking and fading. (Stayfast tops are made to order, so please allow 6 to 10 weeks for delivery.)

Tops are supplied with all snaps and fasteners, but do not include the header rail (except where noted), body hardware or anchor bars.

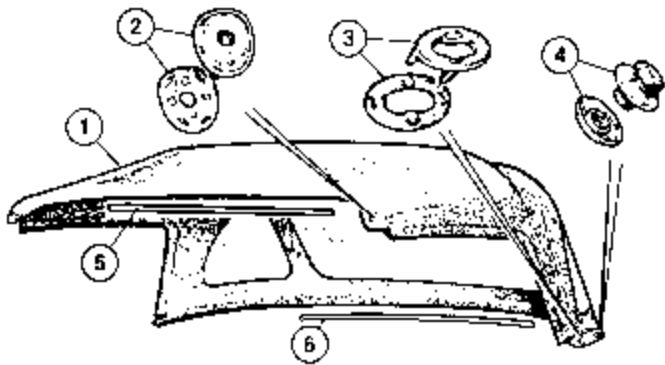

No.	Part No.	Price (each)	Description	Application	Qty. Req.
<b>Tops, Sprite Mki, MkII, Midget Mki</b>					
1	242-180	\$349.99	TOP, black vinyl	} Bugeye, studs on w/s frame thru (c)5476	1
	242-181	\$723.99	TOP, black Stayfast		1
	242-182	\$723.99	TOP, tan Stayfast		1
	242-185	\$349.99	TOP, black vinyl	} Bugeye, bar mount from (c)5477	1
	242-186	\$723.99	TOP, black Stayfast		1
	242-187	\$723.99	TOP, tan Stayfast		1
	242-190	\$359.99	TOP, black vinyl	} Sprite MkII	1
	242-191	\$699.99	TOP, black Stayfast		1
	242-192	\$659.99	TOP, tan Stayfast		1
2	226-308	\$1.09	FASTENER, "Lift-the-Dot"	Bugeye thru (c)5476	A/R
				Sprite & Midget from above	9
3	227-408	\$0.89	EYELET		2
4	227-600	\$10.89	FASTENER, "Tenax" (genuine "Tenax" brand)		4
5	401-030	\$24.99	BAR, top retaining, front	} Bugeye from (c)5477, Sprite MkII, Midget Mki	1
6	401-040	\$34.99	BAR, top retaining, rear		1

# Tops

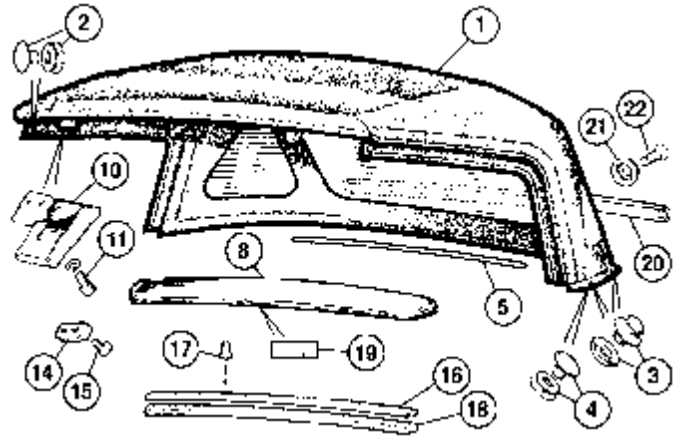

No.	Part No.	Price (each)	Description	Application	Qty. Req.	
<b>Tops, Sprite MkIII-on, Midget MkIII-on (1964-'80)</b>						
1	242-195	\$359.99	TOP, black vinyl	} Sprite MkIII	1	
	242-196	\$699.99	TOP, black Stayfast		Midget MkIII	1
	242-197	\$699.99	TOP, tan Stayfast		1	
	242-175	\$356.99	TOP, black vinyl	} Sprite MkIV	1	
	242-176	\$699.99	TOP, black Stayfast		Midget MkIII	1
	242-177	\$699.99	TOP, tan Stayfast		8 Tenax studs 1967-'68	1
	242-205	\$799.99	TOP, black vinyl w/ header rail	} Sprite MkIV, Midget MkIII, 1275, Midget 1500	1	
	242-200	\$359.99	TOP, black vinyl		1	
	242-203	\$359.99	TOP, tan vinyl		1	
	242-204	\$359.99	TOP, white vinyl		1	
	242-201	\$699.99	TOP, black Stayfast		1	
	242-202	\$699.99	TOP, tan Stayfast		1	
	242-370	\$456.99	TOP, black vinyl, ZW*		6 Tenax studs, velcro	1
	242-371	\$456.99	TOP, white vinyl, ZW*		1969 on	1
	242-372	\$456.99	TOP, tan vinyl, ZW*		1	
	242-375	\$799.99	TOP, black Stayfast, ZW*		1	
	242-376	\$799.99	TOP, tan Stayfast, ZW*	1		
* ZW = zippered rear window						
2	227-108	\$0.49	SNAP ASSEMBLY, female		A/R	
3	227-600	\$10.89	FASTENER, "Tenax" (genuine "Tenax" brand)	Sprite MkIII, Midget MkII	A/R	
				1967-'68	8	
				1969-on	6	
4	227-108	\$0.49	SNAP ASSEMBLY, female	} Sprite MkIII, Midget MkII	2	
5	401-040	\$34.99	BAR, top retaining, rear		1	
8	400-695	\$329.99	HEADER RAIL	} 1964-'80	1	
10	406-230	\$48.99	LATCH, header rail		2	
11	466-385	\$0.39	BOLT, header rail latches		4	
14	406-260	\$0.89	PAD, header rail		2	
15	323-635	\$0.34	SCREW		4	
16	453-930	\$10.99	RETAINER, header rail seal		1	
17	325-288	\$1.99	RIVET SET, 15 pcs., retainer to rail		1	
18	453-610	\$9.99	HEADER RAIL SEAL		1	
19	408-555	\$2.79	LABEL, header rail		} 1967-'80	1
20	400-670	\$22.99	RETAINING STRIP			1
21	226-720	\$0.29	SNAP, male	7		
22	314-310	\$0.69	SCREW, retaining strip	7		



# STANDARD TERMS AND CONDITIONS OF SALE & LIMITED WARRANTY

Last updated: March 17, 2018

PLEASE READ THE FOLLOWING CAREFULLY. By clicking the button "Agree," or otherwise accessing and using our website, and/or by placing an order with Moss Motors, Ltd. ("Moss," "we" "us" "our"), you acknowledge and represent that you are over 18 and have the legal capacity and authority to enter this Terms and Conditions/Warranty Agreement ("Terms"). These Terms constitute a binding agreement between Moss and you.

## 1. AGREEMENT TO TERMS AND PRIVACY POLICY

By accessing and continuing to use our Website (<http://mossmotors.com> "Website"), and/or by placing orders with Moss in any other manner, you are agreeing to these Terms including our Privacy Policy ("Privacy Policy", as found immediately following).

## 2. PRICE

It is Moss' intent that prices in our Catalogues and on our Website are accurate and up to date. However, prices are subject to change without notice. Please inquire about price at the time of purchase.

## 3. LIMITED WARRANTY

Moss is proud to provide one of the longest warranty in the business. Everything we sell is warranted to be free from defects in material and workmanship for 2 years from the date of invoice, with the exception of all superchargers, supercharger components, and supercharger hardware which carry a 1 year warranty. If the product warranted above fails, within the warranty period, Moss will, at its discretion, repair or replace the product. This warranty does not cover labor, failure of related components, normal wear of brake or clutch components or failure resulting from alteration, misuse, accidental damage, faulty installation, or faulty repair. TO THE FULL EXTENT PERMISSIBLE BY LAW, WE DISCLAIM ALL WARRANTIES, EXPRESS OR IMPLIED, OTHER THAN THOSE EXPRESSLY STATED HEREIN, INCLUDING, BUT NOT LIMITED TO, IMPLIED WARRANTIES OF MERCHANTABILITY AND FITNESS FOR A PARTICULAR PURPOSE. If a product/part fails while under warranty, a warranty request should be submitted to Moss' sales department and must be supported by the original Moss purchase invoice, documentation of the failure and, upon request, return of the defective part.

## 4. LIMITATIONS OF LIABILITY

It is Moss' intent that the products sold, and services we provide, always function appropriately and no damages result. However, you understand and agree that any damage that may result is expressly limited (A) TO THE MAXIMUM EXTENT PERMITTED BY LAW MOSS, INCLUDING ITS AFFILIATES, EMPLOYEES, OFFICERS, DIRECTORS, CONSULTANTS AND AGENTS, WILL NOT BE LIABLE FOR ANY DIRECT,

INDIRECT, INCIDENTAL OR CONSEQUENTIAL DAMAGE, OR ANY OTHER DAMAGE, LOSS (INCLUDING LOSS OF PROFIT AND LOSS OF DATA), COSTS, EXPENSES AND PAYMENTS, EITHER IN TORT, CONTRACTUAL, OR IN ANY OTHER FORM OF LIABILITY, ARISING FROM, OR IN CONNECTION WITH (I) THE USE OF, OR THE INABILITY TO USE THE WEBSITE; (II) THE FAILURE OF A PRODUCT OR PART SOLD BY MOSS TO YOU; (III) THE INCORRECT INSTALLATION OF A PART/PRODUCT SOLD BY MOSS TO YOU; (IV) ANY FAILURE, ERROR, OR BREAKDOWN IN THE FUNCTION OF THE WEBSITE; AND/OR (V) ANY FAULT, OR ERROR MADE BY OUR STAFF OR ANYONE ACTING ON MOSS' BEHALF; (VI) THE UNAUTHORIZED ACCESS TO OR ALTERATION OF YOUR TRANSMISSIONS OR DATA; OR (VII) STATEMENTS OR CONDUCT OF ANY THIRD PARTY ON THE SERVICE; AND (B) IN NO EVENT SHALL THE AGGREGATE LIABILITY OF MOSS FOR ANY DAMAGES OR LOSSES IN CONNECTION WITH THE SALE OF PART(S)/PRODUCT(S) EXCEED THE TOTAL AMOUNT OF ANY AMOUNT PAID BY YOU FOR THE PART(S)/PRODUCT(S).

MOSS MOTORS, LTD. DOES NOT WARRANT THAT ITS WEBSITE OR ANY OF ITS FUNCTIONS, INCLUDING ANY ELECTRONIC COMMUNICATIONS WHICH WE SEND TO YOU, WILL BE UNINTERRUPTED OR ERROR-FREE, THAT DEFECTS WILL BE CORRECTED, OR THAT THIS SITE AND THOSE COMMUNICATIONS, INCLUDING BULLETIN BOARDS, OR THE SERVERS THAT MAKE THESE SERVICES AVAILABLE, ARE FREE OF VIRUSES OR OTHER HARMFUL COMPONENTS. THESE SERVICES ARE MADE AVAILABLE TO YOU ON AN "AS IS" AND "AS AVAILABLE" BASIS AND YOU EXPRESSLY AGREE THAT YOUR USE OF THESE SERVICES IS AT YOUR SOLE RISK.

## 5. INSTALLATION NOT INCLUDED

Moss is not liable for injury or damage due to incorrect installation or use of their products/parts. All products/parts and are sold with the understanding that the safe and proper installation and use of the products is the customer's responsibility. It is the customer's responsibility to check with their local laws to determine if the product they have purchased from Moss and then installed on their vehicle may or may not be legal. Follow factory workshop manual procedures and instructions, but use current shop safety standards and common sense. Some tasks will require professional advice which Moss does not provide.

## 6. MODIFICATION OF THESE TERMS

Moss reserves the right, at its discretion, to change these Terms at any time and/or to discontinue any part of the Website. A change to the Terms will be effective (a) ten days following Moss sending a notice to you; or (b) after Moss posts a revised agreement on the Website or in the Catalogue and you subsequently use the Website and/or order a part/product from us.

## 7. GOVERNING LAW/ VENUE FOR ACTIONS

By ordering parts/products from Moss you agree that (a) all claims arising out of or relating to the transaction will be governed by California Law; (b) all claims arising out of or relating to the transaction shall be brought and litigated exclusively in the Superior Court of the County of Santa Barbara (Anacapa Division), California, USA; and (c) you consent to personal jurisdiction in the previously mentioned court.

## 8. GENERAL LEGAL TERMS

If any provision, or part of a provision, of these Terms is held to be unenforceable, the rest of the Terms shall remain intact and be construed without the unenforceable such provision, or part of said provision. Moss may provide you with notices, including those regarding changes to the Terms, by email, regular mail, or postings on the Website and in the Catalogue. A waiver of any term or provision of these Terms will be effective only if Moss expressly states in a writing signed by an authorized representative that Moss is waiving that specified term or provision. These Terms and the Privacy Policy represent the complete agreement between you and Moss and supersede all prior agreements and representations related to the subject matter hereof.

# PRIVACY POLICY

## 1. OUR COMMITMENT TO PRIVACY

This notice describes our Privacy Policy. Our privacy policy is designed to advise you about how we collect, use, and protect the personal information you provide. *By using our website or transacting business with us, you consent to the collection and use of your personal information as described in this Privacy Policy.*

## 2. WHAT INFORMATION IS COLLECTED

(a) **Information You Provide To Us:** We collect any information you enter on our site, or that you give us in any other way. You can choose not to provide certain information, but you may not be able to take advantage of our services and features. (b) **Automatic Information:** When you visit a website, you disclose certain information, such as your Internet Protocol (IP) address and the time of your visit. This site, like many other sites, records this basic information about visits to our site. (c) **"Cookies":** A cookie is a small piece of data that is sent to your browser or mobile device by websites, mobile apps, and advertisements that you access or use. This data is stored on your browser or mobile device and helps website and mobile apps to remember things about you to improve your experience with the website. Most browsers are set up to accept cookies, but you can change your settings to have your browser notify you when you receive a new cookie or to refuse to accept cookies. If you do not wish for cookies to be placed on your computer, most web browsers permit you to prevent that from taking place. However, please keep in mind that these technologies are an important part of how the website works; removing, rejecting or limit-

ing the use of cookies or other similar technologies might affect the availability and functionality of the website. To opt-out of receiving our direct mail or catalogs, you may send us an email at [moss.sales@mossmotors.com](mailto:moss.sales@mossmotors.com) or call us at 800-689-9313.

## 3. HOW AND WHEN THE INFORMATION IS USED

The information we collect is used for administering our business activities i.e., collecting your name, mailing address, credit card information, and e-mail address to allow for us to process and fulfill an order you place on our website. Occasionally we may use the information to notify you about changes to our website, new services, or special offers. If you wish to unsubscribe from our email list you may at any time.

## 4. HOW WE PROTECT YOUR INFORMATION

The privacy and protection of your information is important to us. We do not make any personal information available to third parties without your permission. Your access to some services and content is password protected. We advise that you do not disclose your password to anyone. In addition, we recommend you sign out of password-protected services at the end of your session.

## 5. WHO HAS ACCESS TO THE INFORMATION

Information about our users is important to us. We will not disclose individually identifiable information to any third party without first receiving that user's permission, except as necessary to fulfill your orders and support our marketing activities including direct mail, e-mail, database cleaning

and maintenance, and analysis. They have access to personal information needed to perform their functions, but may not use it for other purposes. We do not sell, rent or trade our customers' personal information to third parties. We may from time to time contract with third party vendors to provide ads to our customers on our behalf via the Internet or to send direct mail or catalogs to customers whom we think may be interested in our products or services. In order to do so, the vendor may collect anonymous information about your visits to our website using a "cookie". Third-party vendors may then pool the anonymous information that they collect from our website with other sources of information, which may include your name and mailing address, for purposes of determining whether you might be interested in receiving direct mail or a catalog.

## 6. METHODS WE USE TO PROTECT YOUR INFORMATION

We use security software to protect the confidentiality of your personal information. When you order from us, we offer a secure server. The secure server software (SSL) encrypts all the information you input before it is sent to us. Our system supports up to 128-bit encryption, one of the highest levels available.

## 7. CHANGES TO PRIVACY POLICY

If our Privacy Policy or procedures change, we will immediately post those changes to our website. Any such changes will be effective immediately upon being posted, unless otherwise stated in the change.

## 8. EFFECTIVE DATE

This Privacy Policy is effective as of March 17, 2018.

- A**  
Accelerator Cable . . . . . 21  
Air Filter  
air pump . . . . . 25  
carb. . . . . A29, 22-24  
Air Horn Kit . . . . . A19  
Alternator . . . . . 78  
conversion . . . . . A35  
Antennae . . . . . A7, A17  
Apparel & Gifts . . . . . A51-A54  
Axle Shafts, rear . . . . . 41
- B**  
Badge Bar & Badges . . . . . A19  
Battery Chargers . . . . . A4  
Bearings  
Engine  
1500 . . . . . 15  
948-1275 . . . . . 10  
front axle . . . . . 44  
rear axle . . . . . 41  
Body Panels  
Bugeye . . . . . 52, 54  
non-Bugeye . . . . . 53, 54  
Bonnet Straps . . . . . A16  
Books, Manuals, & Videos . . . . . A40-A42  
Brakes . . . . . A36-37, 48-51  
hoses . . . . . A37, 50-51  
tools . . . . . A43-A44  
Bulb  
headlamp . . . . . 70  
instrument . . . . . 73  
tail . . . . . 71, 72  
Bumpers, front & rear . . . . . 66-67  
Bushes, suspension  
front . . . . . A38-A39, 44-45  
rear . . . . . 38-A39, 46
- C**  
Cables  
accelerator, choke . . . . . 21  
battery/starter . . . . . 77  
speedo, tach . . . . . 79  
Camshafts  
1500 . . . . . 15  
948-1275 . . . . . A27, 10  
Car Capsule . . . . . A14  
Car Care & Maintenance . . . . . A5, A46-A50  
Car Covers . . . . . A14  
Carburetor Manuals . . . . . A40  
Carburetors  
SU . . . . . A30-A31, 22-23  
Weber . . . . . A31  
Zenith-Stromberg . . . . . 24  
Carpet . . . . . A9, 82  
Choke Cable . . . . . 21  
Clutch . . . . . A28, 34-35  
Cockpit Fittings . . . . . 83  
Coil, ignition . . . . . A34-A35, 76  
Condenser, ignition . . . . . 74  
Connecting Rods  
1500 . . . . . 15  
948-1275 . . . . . 11  
Connectors, electrical . . . . . 73  
Conolly Leather Products . . . . . A47  
Cooling System . . . . . 18-19  
Crankshaft  
1500 . . . . . 15  
948-1275 . . . . . 10  
Cup Holders . . . . . A50
- Cylinder Head  
1500 . . . . . 16  
948-1275 . . . . . A26, 12-13
- D**  
Dash Pad Cover, 1968-80 . . . . . 83  
Dashtop Repair Panel . . . . . A10  
Diaphragm  
Zenith-Stromberg carb. . . . . 24  
SU fuel pump . . . . . 26  
Differential . . . . . 41  
Dipstick, engine . . . . . 6, 8, 14  
Distributors . . . . . A34, 74-75  
Door  
fittings . . . . . 68  
pillars . . . . . 52-53  
seal . . . . . A10, 83  
skins . . . . . 52-53  
Driving Lamps . . . . . A21
- E**  
E.G.R. Valve . . . . . 25  
Electric Fan Kits . . . . . A33  
Electronic Ignition A34, 74-75  
Emission Control . . . . . 25  
Engine Lock Tab Sets . . . . . 11  
Engine Mounts  
1500 . . . . . 14  
948-1275 . . . . . 7, 9  
Engine Performance . . . . . A24-A35  
Exhaust Systems . . . . . A32, 30-33
- F**  
Fan Belts . . . . . 18-19  
Fans, radiator . . . . . A33, 18-19  
Filter  
air pump . . . . . 25  
carb. air . . . . . A31, 22-24  
fuel . . . . . A29  
Fire Extinguisher . . . . . A45  
Flasher Unit . . . . . 77  
Floor Mats . . . . . A12, 82  
Floorboards . . . . . 54  
Fog Lamps . . . . . A20-A21  
Front Suspension . . . . . 44-45  
Fuel Pumps . . . . . A5, A29, 27  
Fuel System  
A29-A31, 26-27  
Fuse Box / Fuses . . . . . 77
- G**  
Gasket Set  
SU carburetor . . . . . 22-23  
Zenith-Stromberg carburetor . . . . . 24  
Gaskets, engine  
1500 . . . . . 14, 16  
948-1275 . . . . . 6, 8, 12  
Gearbox  
1500 . . . . . A28, 40  
948-1275 . . . . . A28, 38-39  
Gearshift Knobs . . . . . A11, 39, 40  
Generator . . . . . 78  
Gifts . . . . . A51-A54  
Grille Badges . . . . . A19  
Grilles . . . . . 59  
Grommets . . . . . 62
- H**  
Halfshafts . . . . . 41  
Handbrake . . . . . 49  
Hats . . . . . A52  
Head Rests . . . . . 87  
Headers . . . . . A32, 30  
Headlamps . . . . . A21, 70  
Heaters . . . . . 20-21  
Hinges  
door . . . . . 68  
hood . . . . . 57-58  
trunk lid . . . . . 60  
Hood Straps . . . . . A16  
Horns . . . . . A18-A19, 77  
Hub Caps . . . . . 47
- I**  
Ignition System . . . . . A34-A35, 74, 76  
Inner Tubes . . . . . A22, 47
- J**  
Jack . . . . . 47  
Jack Stowage Bag . . . . . 46
- K**  
Key Blanks . . . . . A10  
Key Fobs . . . . . A53  
Knockoffs . . . . . A22, 47  
hammers . . . . . A22, 47
- L**  
Lamps  
license plate . . . . . 72  
dashboard . . . . . 73  
front . . . . . A21, 70-71  
rear . . . . . A20, 71-73  
License Plates . . . . . A18  
frames . . . . . A18  
mounts . . . . . 57, 67  
Lifter  
1500 . . . . . 16  
948-1275 . . . . . 13  
Locking Gas Caps . . . . . A17  
Lowering Springs . . . . . A39  
Luggage Racks . . . . . A18
- M**  
Manifolds . . . . . A30, A32, 28-29  
Mirrors  
door & fender . . . . . A16, 63  
windshield . . . . . 55  
Mufflers . . . . . A32, 30-33
- N**  
Needles  
SU Carburetor . . . . . 22-23  
Zenith-Stromberg carburetor . . . . . 24  
Number Plate Mounts . . . . . 57, 67
- O**  
Oil . . . . . A48, A50  
filter  
1500 . . . . . 14  
948-1275 . . . . . A28, 7, 9  
press./water temp. gauge . . . . . A10, 79  
pump  
1500 . . . . . 14  
948-1275 . . . . . 7, 9  
cooler kit . . . . . A28-A29  
Overriders . . . . . 56, 66-67
- P**  
P.C.V. Valve . . . . . 25  
Paint . . . . . A47  
Panel Kits . . . . . A9, 82  
Patches . . . . . A54  
Pistons  
Engine  
1500 . . . . . 15  
948-1275 . . . . . 10  
Rings  
1500 . . . . . 15  
948-1275 . . . . . 10-11  
brake caliper . . . . . 50  
Production Data . . . . . 3  
Pulley  
Crankshaft  
1500 . . . . . 15  
948-1275 . . . . . 10  
Pushrods  
1500 . . . . . 16  
948-1275 . . . . . 13
- R**  
Radiators . . . . . 18-19  
Radios . . . . . A7  
Rear Axle . . . . . 41  
Rear Suspension . . . . . 46  
Release Bearing, clutch . . . . . 34  
Ring Gear  
1500 . . . . . 15  
948-1275 . . . . . 10  
Rocker Arms  
1500 . . . . . A26, 16  
948-1275 . . . . . 13  
panels . . . . . 52, 53  
Rocker Shaft  
1500 . . . . . 16  
948-1275 . . . . . 13  
Rotor, ignition . . . . . A34, 74-75
- S**  
Seat Components . . . . . 84-85  
Seat Kits/Covers . . . . . A8, 84-85  
Seatbelts . . . . . A13  
Sending Unit, fuel tank . . . . . 27  
Shift Knobs . . . . . A11, 39, 40  
Shock Absorber  
front . . . . . A38, 44  
rear . . . . . A38, 46  
Shop Tools & Equipment . . . . . A42-A47  
Side Curtains . . . . . A15, 65, 88  
Signs . . . . . A53-A54  
Slave Cylinder, clutch . . . . . 35  
Sound Deadener . . . . . A12  
Spark Plugs . . . . . 76  
Speedometer Cable . . . . . 79  
Spring, front, coil . . . . . A39, 44  
Spring, rear, leaf . . . . . A39, 46  
Sprockets, timing chain  
1500 . . . . . 15  
948-1275 . . . . . A27, 11  
Stainless Steel Exhaust . . . . . A32  
Starter Cables . . . . . 77  
Starter . . . . . 79  
Steering Wheels . . . . . A11, 42  
Steering . . . . . A39, 43  
SU Carburetors . . . . . A30-A31, 22-23
- Sun Visors . . . . . A10, 55  
Supercharger . . . . . A24-A25  
Suspension  
front . . . . . A38-A39, 44-45  
rear . . . . . A38-A39, 45  
Sway Bar . . . . . A38  
Switches . . . . . 80-81  
Swivel Pin . . . . . 44
- T**  
Tachometer Cable . . . . . 79  
Tappets  
1500 . . . . . 16  
948-1275 . . . . . A27, 13  
Thermostat . . . . . A33, 13, 18-19  
Tie Rod Ends . . . . . 43  
Timing Chain  
1500 . . . . . 15  
948-1275 . . . . . 11  
Tonneau Covers . . . . . A15, 86-87  
Tools . . . . . A22, A42-A45  
Top Fittings . . . . . 88  
Tops . . . . . A15, 89  
Transmission  
1500 . . . . . 40  
948-1275 . . . . . 38-39  
Trim Rings, wheel . . . . . A22, 47
- U**  
U-Joint, driveshaft . . . . . 41  
Upholstery Kits . . . . . A8-A9, 82-83
- V**  
Vacuum Advance Unit . . . . . 74-75  
Valve  
cover plates, 948-1275 . . . . . 12  
covers . . . . . A26  
inlet & exhst, 1500 . . . . . 16  
inlet & exhst, 948-1275 . . . . . 13  
Voltage Regulator . . . . . 77
- W**  
Water Pumps . . . . . 18-19  
Water Temp. & Oil Gauge . . . . . 80  
Weber Carburetors . . . . . A31  
Wheel Cylinders . . . . . 49  
Wheel Tools . . . . . A22  
Wheels  
road . . . . . A23, 47  
steering . . . . . A11, 42  
Windows, door . . . . . 65  
Windshield Wipers/Washer . . . . . 69  
Windshield . . . . . 55  
Wire Wheels . . . . . A23, 47  
Wiring Harnesses . . . . . 73  
Wishbones . . . . . 44