

ISSUE 20

PARTS & ACCESSORIES FOR YOUR
**CLASSIC
MINI**

Restore • Maintain • Modify

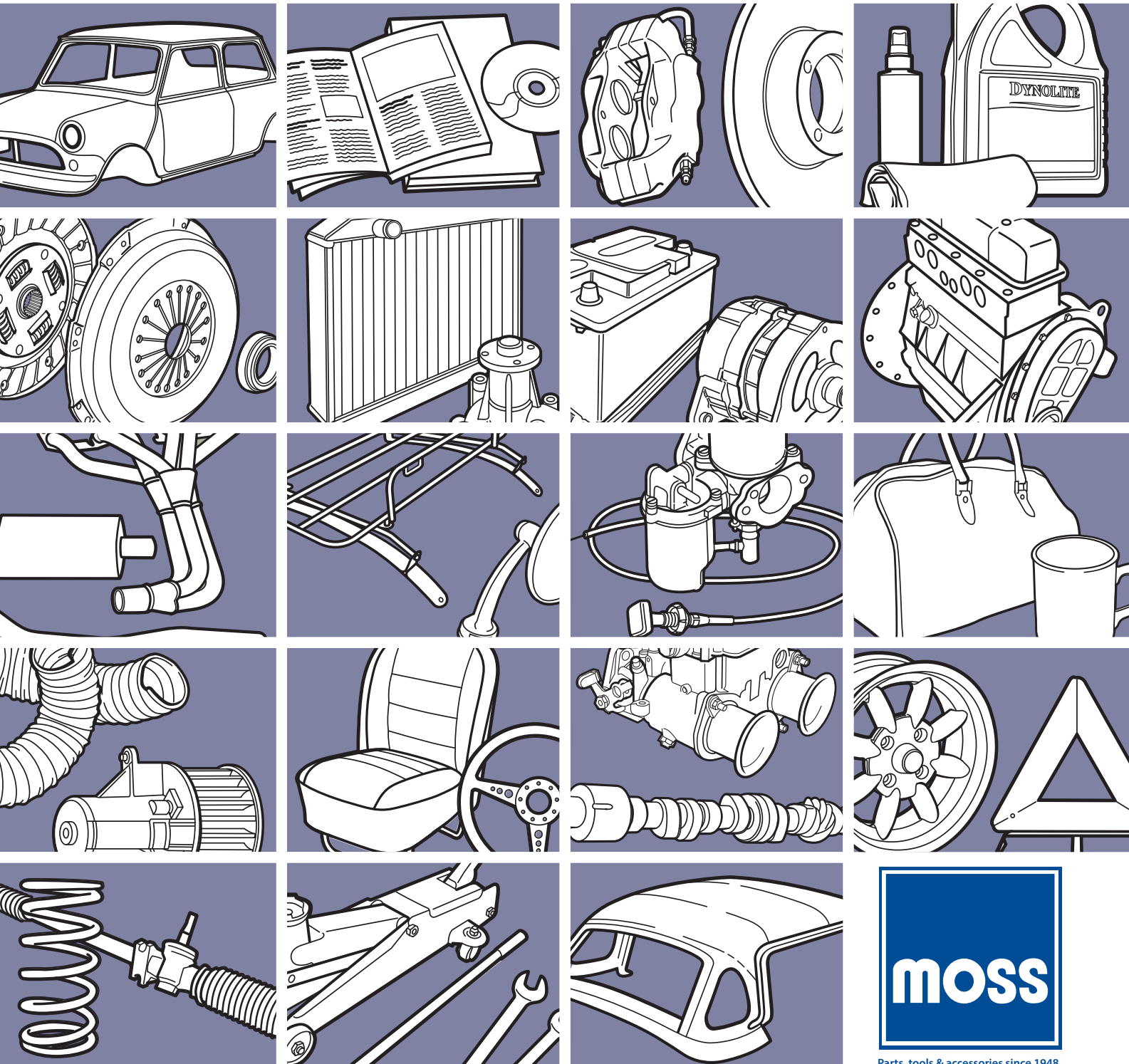

Parts, tools & accessories since 1948.

HOW TO ORDER

ORDER ONLINE

Ordering online is quick and straight forward. Simply search by part number or browse by model and component categories. Our site features detailed schematics so identifying the correct part is easy, right down to the last nut and bolt. Should you get stuck, our knowledgeable sales staff are ready to help using our live-chat feature.

Add the parts that you need to your basket and head to the checkout for delivery and payment options. Once checked out, you will receive a confirmation of your order via email, by which time your parts will be being picked and packed, ready to be sent to your door.

ORDER THROUGH A BRANCH

Whether you are visiting, calling or emailing, our knowledgeable branch staff will be happy to help you get the parts that you need. They are car enthusiasts too and understand the challenges that sometimes come with identifying the right parts for rare and classic cars. Of course, the more information about your vehicle that you have to hand, the quicker and easier it will be for us to help.

Arranging to collect parts from our branches is easy, our teams will let you know once your order is ready. Alternatively, they can dispatch your order directly to you.

PRICING

Due to constant variations of world markets and currency fluctuations the prices in this catalogue are subject to change. We make every attempt to keep prices competitive and stable, however in common with all other suppliers in our industry, we reserve the right to alter prices without prior notice. For the latest prices, please call or visit moss-europe.co.uk.

All prices are per unit (unless otherwise stated) and include (UK) VAT at 20% (where applicable). Please note EU countries may be charged at their local VAT rate, countries outside the EU will not be charged VAT. Prices are correct at the time of going to print, postage & packaging is not included. E&OE.

SHIPPING & DISPATCH

Orders for delivery in the UK may be dispatched by regular post for small/lightweight items, larger items may be dispatched via a courier. Please call us for the best delivery option for your order and the latest delivery prices.

For delivery outside the UK we offer the following services. Economy delivery (by road): 2 to 5 days (approximately). Express delivery (by air): 1 to 2 days (Guaranteed). For small and low value orders we also use airmail. For these services, please ask for prices and the best delivery option when you place your order. Most deliveries (except airmail) are 'trackable', (inc: e-mail updates and internet access for selected carriers). Please remember, all carriage charges are dependent on either gross weight or volumetric weight, whichever is greater. If a quotation is required prior to placing your order, please contact a member of the sales department. Alternatively, you can arrange your own collection.

UK OPENING TIMES*

Open Monday to Friday
8.30am to 5.30pm

Saturday
9.00am to 1.00pm
(Closed Sunday & Bank Holidays)

See website for Paris opening times

*Opening times may vary, please call your nearest branch for more information.



**90 DAY
MONEY BACK
PEACE OF MIND
WARRANTY**

It's simple, if you change your mind for any reason, all uninstalled parts still in their original condition and packaging may be returned to us within 90 days from the date of purchase for a full refund. A copy of the original invoice or picking label must accompany the return. Return freight is paid by the customer, unless returned due to our error.

In the event of a part failing in use, all parts are warranted against defects in materials and workmanship for 12 months from the date of purchase. Please remember that all returns must be accompanied by the original invoice, return freight will be reimbursed. For more details see our website or contact your local branch.

**FIND US ONLINE FOR THE
LATEST PRODUCTS, NEWS,
FEATURES AND SALES.**

STAY IN TOUCH

-  Facebook
facebook.com/mosseurope
-  Twitter
twitter.com/mosseurope
-  Instagram
instagram.com/mosseuropeltd

BUY ONLINE

-  Moss Websites
moss-europe.co.uk
- moss-europe.fr



LONDON

Unit 16, Hampton Business Park
Bolney Way, Feltham
TW13 6DB

London Tel
+44 (0)20 8867 2020

Email
sales@moss-europe.co.uk

Fax
+44 (0)20 8867 2030



BRADFORD

Unit 12-13, Acorn Park Ind. Est.
Otley Road, Shipley
BD17 7SW

Bradford Tel
+44 (0)1274 539 999

Email
bradford@moss-europe.co.uk

Fax
+44 (0)1274 539 990



BRISTOL

1-3 Elton Street
Bristol
BS2 9EH

Bristol Tel
+44 (0)117 923 2523

Email
bristol@moss-europe.co.uk

Fax
+44 (0)117 942 8236



MANCHESTER

111-117 Stockport Road
Stockport, Cheshire
SK3 0JE

Manchester Tel
+44 (0)161 480 6402

Email
manchester@moss-europe.co.uk

Fax
+44 (0)161 429 0349



PARIS

7 rue Chaponval
ZAC du Cornouiller
78870 Bailly, France

Paris Tel
+33 (0)1 30 80 20 30

Email
sales@moss-europe.fr

Sav
+33 (0)1 30 80 21 50

A	Dummy filler neck A35	Lamp covers A40	Superpro bush kits A29
Adjusta ride kits A28	Duplex gear set A04	Lamps A36	Suspension cone compressor . A57
Aerials A57	DVDs A59	Lightweight flywheels A11	Suspension kit A28
Air filters A23	Dynamat A51	Limited slip differentials A12	T
Air vent set A47	E	Lower arms A27	Thermal mugs A57
Alarm & immobiliser A45	Edge trim finisher A55	M	Throttle linkages A13
Alloy top cap A04	Electric window kit A45	Magnetic oil trap A11	Throttle pedals A49
Ashtrays A47	Engine steady bushes A05	Manifold gasket A16	Tie bars A27
B	Engine steady kit A05	Mirror (interior) A47	Tower bolts A28
Badges A40-41	Exhaust insulation A16	Mouldings A30	Tread plates A49
Battery cut-off switches A25	Exhaust manifolds A15	Mudflaps A38	U
Bezel tool A57	Exhaust systems A17-19	N	Under felt kit A53
Bonnet hinges A32	F	Number plate A32	Union flag A59
Bonnet release kit A49	Flat top pistons A04	O	V
Bonnet straps A32	Flywheel puller A57	Oil catch tanks A10	Valves A04
Books & manuals A59	Footwell light kit A45	Oil cooler radiators & kits A10	Valves guides A04
Boot trim A54	Footwell mats A55	Oil cooler thermostats A10	Valves spring sets A04
Boot handles A32	Fuel caps A35	Oil filters A23	W
Brake drums A27	Fuel pump inertia switch A25	Oil pick up pipe A11	Waterproof blanket A59
Brake hoses A26	Fuel pumps A25	Oil pumps & valves A10	Webber Carburettor A12
Brake master cylinder A26	G	Oil temperature gauge adaptor . A10	Wheel arch sets/kits A38
Brake pads A26	Gauges & accessories A46-47	P	Wheels A39
Brake parts A26	Gear kits A11	Patches A57	Wind deflectors A32
Brake servo kit A27	Gear knobs A51	Pedal box assembly A08	Window module A45
Breather Filters A23	Gear lever gaiter A53	Piston ring set A04	Windscreen wiper kits A31
Bumper & overrider kit A31	Gear lever gaiter finisher kit A51	Power Socket (12v) A49	Windscreen washer systems . . A31
C	Gearboxes A11	Pro start push button A45	
Cam followers A04	General switches A35	Q	
Cam gear locating key A04	Grilles A43	Quick shift gear kits A11	
Camber brackets A28	H	R	
Camber gauge A57	Handbrake grip A49	Radiators A09	
Camshafts & accessories A07	Handbrake quadrant A27	Radios A56	
Car cover A59	Head gaskets A05	Ram pipes A23	
Carburettors A12	Headlamp accessories A35	Rear hubs A27	
Carpet sets A53	Headlamp conversion kit A37	Rear silencer fittings A16	
Central locking kit A45	Headlamps A37	Red start button A45	
Centre consoles A44	Headlining A54	Rocker assemblies A07	
Chassis plates A40	Headlamp protectors A35	Rocker cover & fittings A08	
Clutches A11	Headlamp relay kits A37	Rocker shaft A07	
Coil clamp & cover A21	Heat shields A16	S	
Coil over kit A29	Heated windcreens & wiring kit A30	Seal belts & harnesses A48-49	
Coil spring conversion A28	Heater tap A08	Seat runners A49	
Con rods A04	Horns A32	Seats & frames A54	
Cooling fan kits A09	HT leads A21	Service parts A60-62	
Cooling fans A09	Hub cap A39	Shock absorbers A29	
Cross Pin differentials A12	I	Silicone hoses A08	
Cup holder A50	Ignition lead numbering set A21	SmartScreen wash/wiper A30	
Cylinder heads A05	Ignition systems A22	Solid rocker spacer set A07	
Cylinder head stud kit A07	Indicator lens kits A35	Spark plugs & terminals A20	
D	Inlet manifolds A13	Speakers A56	
Dash kits A44	Interior trim A55	Stage one tuning kit A15	
Dash liner kits A55	K	Starter motors A12	
Dashpot covers A12	Key fobs A57	Steering column drop bracket . A49	
Decals A40-41	Keyless entry kit A45	Steering wheel bosses A50	
Distributors A21 & A22	Klingersil gasket A09	Steering wheels A50-51	
Dipsticks A11	L	Subframe mountings A28	
Door handle escutcheons A32	Lamp brackets & switch A35	Sump guard A30	
Door handles (exterior) A32	Lamp conversion kits A35-36	Sun visors A54	
Door handles (interior) A47			
Door mirrors A33			
Door pocket trim A55			

Sections

Performance A04

Exterior A30

Interior A44

Personal A57

Service Parts A60

BLACK & WHITE Restoration Section

Restoration
Parts 01

Ordering
Information 02



Moss Europe Ltd are proud to support the FBHVC

The Federation of British Historic Vehicle Clubs exists to uphold the freedom to use old vehicles on the road.

Where the price is replaced with NCA this part is Not Currently Available. Please visit our website (moss-europe.co.uk) or call our sales staff for the latest availability information or to enquire if we can offer an alternative part.

CMcat ©Copyright Moss Europe Ltd. August 2018. Printed in the U.K. All rights reserved. No part of this publication may be reproduced, stored in a retrieval system, or transmitted in any form by any means, electronic, photocopying, recording or otherwise without prior written consent of Moss Europe Ltd. Please note: Product colours may vary slightly to samples featured in this catalogue, due to the limitations of colour printing.

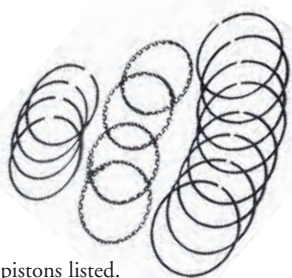

PISTON RING SET

Replacement piston ring sets for the pistons listed.

Ring set +20 for 3382 +20 pistons CAJJ3379/20 . . . NCA



CAJJ3382/40

FLAT TOP PISTONS

These pistons are made from lightweight alloy AE109TF specification with two heat treatments. They are designed for durability yet lightweight and have a crown thickness 1.2mm thicker than other leading pistons. Ideal for machining for long stroke cranks. Sold individually complete with rings.

Flat top pistons +20 1275cc CAJJ3382/20 NCA

Flat top pistons +40 1275cc CAJJ3382/40 . . . £74.00

Flat top pistons +60 1275cc CAJJ3382/60 . . . £74.00



CON RODS FOR COOPER S

Reproduced to original specification, these EN24V con rods are the strongest production A series rod produced. 1.625" big end journal size with 5.75" centres.

Con rod (each) AEG624 £156.20



DUPLEX GEAR SET

It is preferable to change from single row chain (simplex) to twin row chain (duplex) as the duplex is less prone to stretching. The cam timing can also be optimised via an adjustable cam gear, or via offset cam keys. Please see manufacturers data for correct timing figures.

Kent cams vernier adjustable duplex kit TMG10828 . . £117.00



CAEG579

LIGHTENED CAM FOLLOWERS

Lightening the valve train helps improve engine response. Our lightened cam followers weigh just 40g and come with an oil drain hole.

Lightened cam follower (each) TMG10709 . . . £8.15

Lightened cam follower set CAEG579 . . . £55.70



CAM GEAR LOCATING KEY

These offset keys make getting the best out of your camshaft easy. Please see manufacturers data for correct timing figures.

Cam gear locating key 1° offset MGS108251 . . £10.00

Cam gear locating key 2° offset MGS108252 . . £12.00

Cam gear locating key 3° offset MGS108253 . . £12.00

Cam gear locating key 4° offset MGS108254 . . £12.00

Cam gear locating key 5° offset MGS108255 . . £10.00

Cam gear locating key 6° offset MGS108256 . . £12.00

Cam gear locating key 7° offset MGS108257 . . £9.20

Cam gear locating key 8° offset MGS108258 . . £9.50

Cam gear locating key 9° offset MGS108259 . . £9.00

Cam gear locating key kit 2°, 4° & 7° offset . . . MGS10725 . . £30.00



ALLOY TOP CAP

Alloy top cap (each) TMG10816 . . £17.30
(Half the weight of steel).



VALVE SPRING SETS

Dual spring set 200lbs - road use TMG10807 . . £39.00

Dual spring set 250lbs - race use TMG10808 . £131.50



VALVE GUIDES

Bullet shaped valve guides allow better flow without loss of durability.

Bronze alloy valve guides are required when fitting EN214N steel valves.

Bronze valve guide set (set of 8) TMG10819 . . £59.40

Iron valve guide tapered nose (each) 12G1963 . . . £2.12

Top hat seal (Rover valve stem oil seals) ADU4905 . . . £0.80



VALVES

Our competition valves are produced in EN214N steel and require installation with bronze valve guides (TMG10819). They are single groove collets (88G459).

Inlet valve 35.6mm high flow 1275cc (EN214N) . CAEG544 . . . £17.00

Exhaust valve 29.4mm high flow 1275cc (EN214N) . CAEG106 . . . £16.00

Rimflow valves are considered to be the best valves on the market. Produced in EN214N steel but they have chromed plated stems to enable them to be installed with iron guides although we recommend bronze guides as these help with heat dissipation. Rimflow valves use single groove collets (88G459).

Rimflow inlet valve 35.6mm 1275cc (EN214N) . MST2021 . . . £33.30

Rimflow exhaust valve 31mm 1275cc (EN214N) . MST2012 . . . £31.20

Valve 'Cotter' (2 per valve) 88G459 . . . £1.25

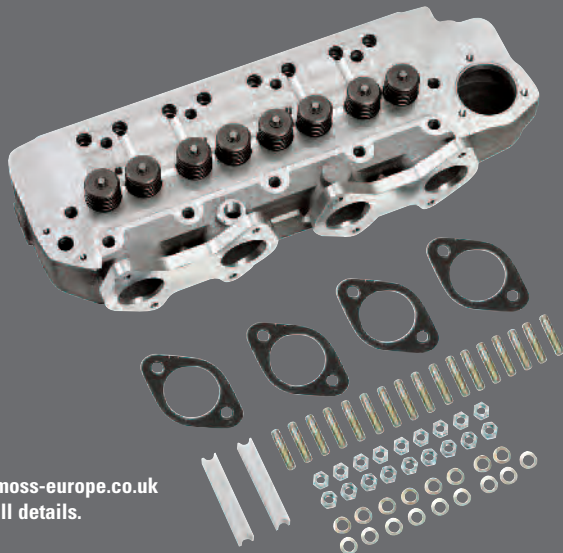

See moss-europe.co.uk for full details.

ALLOY CYLINDER HEAD - CROSSFLOW

Add power to your A Series with this 7 port crossflow aluminium cylinder head. The crossflow design and larger inlet ports overcome the Siamese head's breathing restrictions providing as much as 25% prior to further modification.

The cylinder head is lighter weight and features an integrated cast inlet manifold (for DCOE carbs or throttle bodies); has an increased air flow rate; runs cooler and allows for higher compression ratios. Special spark plugs are required.

- Alloy cylinder head - crossflow assembled 451-808 . . .£1,370.00 (Assembled with valve guides, seats, valves & springs)
- Alloy cylinder head - crossflow bare 451-807 . . .£1,245.00 (Fitted with valve guides & seats)
- Spark plug - NGK (each) ER9EH £14.40

BEST AVAILABLE



ENGINE STEADY KIT

A common problem with Minis is their tendency to destroy engine mounts and steady bar bushes, leading to exhaust down pipe breakage. This is the best engine steady kit available. It mounts neatly on the top two bolts of the water pump and on to the bulkhead. It has an adjustable tie rod with rubber bushes, but can be uprated with a one piece SuperPro bush. Suitable for all models including LHD cars.

- Ultimate engine stabiliser kit ABR024 £37.80
- Solid bush with sleeve (each, 2 per bar) CRC5329SP . . . £4.82



POLY ENGINE STEADY BUSHES

We recommend using polyurethane engine steady bar bushes as they give maximum control and are very hard wearing. We supply a polyurethane bush to fit the top RH steady bar from the engine to the bulkhead (below the master cylinders), this is a solid one piece bush for maximum control.

Note: Always install polyurethane bushes with grease provided.

- Solid bush with sleeve (each, 2 per bar) CRC5329SP . . . £4.82

UPRATED HEAD GASKETS

To reduce the risk of head gasket failure on high compression performance engines it is wise to fit one of these uprated, copper faced, head gaskets. The manifold gasket is to be used when the exhaust and inlet ports have been modified on 1275cc cylinder heads.

- Copper asbestos competition head gasket 1275cc AHT188 £20.80
- Uprated head gasket 998cc MST207 £11.00
- Uprated head gasket 1275cc MST208 £16.50
- Competition manifold gasket large ports 1275cc . TMG10836 . . . £4.44



ALLOY CYLINDER HEAD - 5 PORT

Alloy cylinder heads are an excellent alternative to the original cast iron unit as they are lighter and manufactured with design improvements. The water jacket has been improved to prevent the creation of hot spots and the valves are repositioned to allow up to 38mm inlet and 32mm exhaust valves. Special spark plugs are required.

- Alloy cylinder head - 5 port assembled 451-876 . . .£1,184.00 (Assembled with valve guides, seats, valves & springs).
- Alloy cylinder head - crossflow bare 451-875 . . .£1,122.00 (Fitted with valve guides & seats).
- Spark plug - NGK (each) DCPR7E £6.56



STAGE 3 IRON CYLINDER HEAD - 5 PORT

Cylinder head assembly Stage 3 unloaded, ports enlarged and chambers reshaped new 35.6mm inlet and 31mm exhaust, bronze guides and Moss ST valve springs.

- Stage 3 iron cylinder head TMG10803B . £800.00





Building a retro replica?..

Here are a few retro parts from the catalogue to help you recreate that style and transform your Classic Mini.

Engine		Lamps	
Alloy cylinder head (bare)451-875£1,122.00	Period boot lamp 576 fog	BHA4399 £84.00
Roller rocker kit 1.5:1 1275cc	TMG10848 NCA	Chrome spot lamp Cooper (pair)	GAC4610 £44.50
Duplex vernier gear kit A Series	TMG10828 £117.00	Chrome stone guard (pair)	GAC8000X £12.14
Kent camshaft rally pin A SeriesKMD286P £148.00	Brakes	
Manifold gasket 1275cc large port	TMG10836 £4.44	Alloy Superfin brake drum (pair)	MT1210 £80.00
Competition copper head gasket 1275cc	AHT188 £20.80	Mintex M1144 pads 8.4" disc	STR5051 £58.80
Kent 11 stud + nut set comp	MGS10864 £231.20	Suspension	
Cooling		Adjustable lower arm rose-joint (pair)	C-AJJ3363 £114.00
High flow alloy rad (side mount)	MT3104 £255.00	Adjustable camber rear bracket (pair)	WPT90021 £39.60
Revotec fan kit (side mount rad)	RFK80 £203.90	Spax front stand. height (pair)	GAC84011XPR £139.70
13 row oil cooler heavy duty	ARA221X £134.00	Spax rear stand. height (pair)	GAC84031XPR £139.70
Oil cooler stainless steel pipes (1985 on)	OCHK106 £60.60	Heavy duty adjustable front tie bar (pair)	WPT9003X £27.40
Transmission		Exterior	
Straight cut gear kit A+	CSTN77 £520.00	Stainless steel sump guard	MT1207 £70.00
Electrical		Wheel arch set group 2 for 6J	MRAC402 £62.00
12v sports coil	TT2981 £21.50	Works bonnet strap tan	222-729 £18.25
High torque starter motor (inertia type)	GXE4404X £222.80	Lucas spot/fog lamp cover - black (each)	162-705 £58.30
High torque starter motor (pre-engaged type)	GXE4527X £222.80	Heated laminated windscreen (Monte Carlo) - clear	24A2236HM £269.60
Exhausts		Interior	
RC40 sport exhaust (fits MT6101)	GEX40RC £60.76	Full harness red 3 point	SBH605RED £45.00
Freeflow manifold Cooper	MT6101 £103.50	Full harness red 4 point	SBH655RED £51.00

CYLINDER HEAD STUD KIT

You should consider the strength and reliability of all the critical fasteners used on your engine. Increased reliability can be obtained for mild states of tune by replacing the head studs and nuts with uprated versions. The greater strength of these studs will restrict stretching under pressure and therefore keep the head and gasket securely in place.

Kent cams 9 studs and nuts competition kit . . . TMG10864 . **£194.20**
 Kent cams 11 studs and nuts competition kit . . . MGS10864 . **£231.20**



TMG10864



EN24 nickel chrome moly steel studs, competition head stud kit (11 studs, nuts & washers). This special kit was developed to replace the increasingly inconsistent standard items. The studs are manufactured in selected hi-grade steel and produced to exacting specifications. These studs do not stretch, so they pull the head down, not the thread up, this vastly increases head gasket life, even on high compression engines. Special thick washers, countersunk on one side, help clamping capability and reduce thread bottoming of the nuts.

The 12 point skirted nuts help to increase torque accuracy through better engagement. Note that even replacing the head bolt with a stud, only torque that stud to the factory recommended spec (25ft/lbs), the other studs can be torqued to 65ft/lbs with oil, 55ft/lbs with ARP lube.

11 studs and nuts competition kit AHT280 **£70.00**

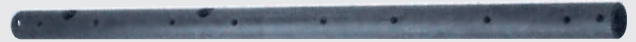

UPRATED ROCKER SHAFT

To enhance valve train strength and reliability especially in high revving engines.

Tufrided rocker shaft TMG10817 . . . **£29.00**



SOLID ROCKER SPACER SET

The spacer replaces the springs reducing side loading on the rocker arms cutting resistance and creating less drag.

Solid rocker spacer set (set of 3) CAEG392 . . . **£14.00**

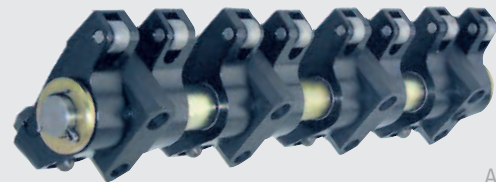

AHT438

UPRATED ROCKER ASSEMBLIES

Roller rockers are stronger than the standard set up and are designed to operate the valves with less resistance, these kits also give higher lift than standard at a ratio of 1.5:1 instead of 1.3:1. Always use with uprated valve springs and check carefully for clearance.

1.5:1 ratio rocker assembly 1275cc AHT438 . . . **£272.40**

1.5:1 ratio titan rocker assembly 1275cc TMG10848 . . . **NCA**



KENT PERFORMANCE CAMSHAFTS

All the Kent camshaft applications/part numbers below with the suffix 'P' are for the original pin drive oil pump/camshaft. If you have changed your camshaft and oil pump to either 'Star' drive or 'Metro Slot', use the suffix 'S' or 'M' on the part number.

To assist in selecting a suitable camshaft we have prepared a table showing their various characteristics, these will change from engine to engine and with other modifications such as carburettor or valve size. A scatter profile is where the cam timing on No. 2 and 3 engine cylinders has been altered slightly to combat the poor scavenging of the siamese port design. This will benefit both the tickover and high end performance. The effect of a larger engine is to lower the camshaft's power range slightly.

Care must be taken to ensure that installation is carried out correctly and

that components all work together or you will not get the expected power output or reliability. It is essential that the new cam is fitted with new followers as they mate with the lobe that they run on and should never be used on another lobe.

Lightened and Tufrided followers wear more slowly and put less load on high lift cam lobes, they are also manufactured with a drainage hole. Another essential is the special lubricant that must be used with all new cams, it provides vital lubrication during initial starting and protects your cam from extreme wear in its first minute of use.

KEN2



TT2929

Camshaft accessories

Don't forget the camshaft assembly lubricant or the cam timing degree disc, you will need this to set your cam timing.

Cam lubricant 250ml KEN2 **£8.30**

360° cam timing disc TT2929 **£7.20**

Camshaft Type	Part No.	Price	Inlet Timing	Exhaust Timing	Duration Inl - Exh	Cam Lift	Description
Fast road	KMD266S	£148.00	24/56	61/29	260-270°	0.263"-0.270"	1275cc smooth idle
Road rally	KMD276S	£148.00	29/61	66/34	270-280°	0.293"-0.315"	1275cc slightly lumpy idle excellent street cam
Rally scatter	KMD286SPS	£230.00	34/66	71/39	280-290°	0.315"-0.324"	1275cc lumpy idle max street cam
Race	KMD296M	£148.00	39/71	76/44	296-300°	0.324"-0.340"	1275cc race/1380cc slightly lumpy
Race scatter	KMD296SPM	£184.00	39/71	76/44	296-300°	0.324"-0.340"	1275cc race/1380cc slightly lumpy



GAC4068P

GAC4068R

GAC4068B

ALLOY ROCKER COVER & FITTINGS

An alloy rocker cover will improve the appearance of your engine bay and, as an added advantage, will help to muffle valve train noise. Always fit a new gasket when replacing your rocker cover, and do not over tighten rocker cover nuts. We offer a range of accessories for the rocker cover including anodised T bars for a custom appearance.



GAC4069FK

WPA9007X

- Ribbed rocker cover - polished GAC4068P . . . £26.40
- Ribbed rocker cover - red GAC4068R . . . £37.00
- Ribbed rocker cover - blue GAC4068B . . . £37.00
- Fitting kit for rocker cover GAC4069FK . . £15.98
(Fitting kit includes: Oil cap, seals and chrome spacers/nuts/washers).
- Ribbed rocker cover kit - polished WPA9007X . . . £38.40
(Kit includes: Rocker cover GAC4068P and fitting kit GAC4069FK).



T BARS

WPA9029X

- Rocker cover knurled nuts (pair) - chrome WPA9029X . . . £9.60
- Rocker cover T bars (pair) - chrome WPA9039X . . . £5.40
- Rocker cover T bar (pair) - anodised blue WPA9039B . . . £8.00
- Rocker cover T bars (pair) - anodised red WPA9039R . . . £8.00

8G612CP

8G612



GUG705009VC

- Chrome filler cap 8G612CP £7.60
- Matt steel filler cap 8G612 £7.20
- Washer & grommet kit GAC4069WK . . £5.00
- Rocker cover gasket GUG705009VC . . £1.32



PEDAL BOX ASSEMBLY

This Mini pedal box is a lightweight mild steel under-slung design, that offers the driver the highest level of efficiency in this critical area. The ergonomic design features a fabricated lightened steel brake and clutch pedal with oil impregnated spherical bushes that sets new standards in pedal box design.

This pedal box is fitted with a bias bar that operates a dual master cylinder braking system, giving total control over the braking from front to rear.

Kit contains: 1 x 3 pedal Mini pedal box, with bias bar, 3 x master cylinders, 1 x clevis, 3 x reservoir, 3 x stainless steel 560mm long feed hoses, 1 x bias cable adjuster.

Pedal box assembly (brake bias 6:1 ratio) MPB1275 . . . £773.80



HEATER TAP

This is the closest you will get to an original Cooper S heater tap for that added retro look. This tap allows water to flow from the head to your heater, a perfect retro replacement if your heater taps fails.

Heater tap (non standard) JJC10018 £33.60



COBALT SILICONE HOSE SETS WITH CLIPS

Upgrade the cooling system with these high quality multi-ply silicone hoses. Available in a choice of colours they include stainless steel clips, ensuring a long life. These kits fit all side mounted radiator models, except SPI and MPI. Trimming of the top hose is required to suit your car. Instructions included.

- Cobalt silicone hoses - black MT3205 . . . £128.40
- Cobalt silicone hoses - blue MT3206 . . . £128.40
- Cobalt silicone hoses - red MT3207 . . . £128.40



HIGH PERFORMANCE RADIATORS

A 2 core radiator is ideal for fast road while for race applications a 4 core is best where extreme cooling is required. For the ultimate cooling use our alloy radiator, suitable for all applications due to better heat sinking through the aluminium construction and it looks great! Our special 3 core fast road radiator has been developed to include an M22 x 1.5 threaded boss in the header tank, this allows easy fitting and adjustment of the Revotec fan controller or installation of thermal switches.

- 2 core high performance radiator - fast road GRD4442 . . . £160.00
- 2 core high perf. radiator with fan switch - fast road .GRD4443 . . .£160.00
- 3 core high perf. radiator - boss in header tank . . GRD4442TDF £77.10
- 4 core high performance radiator - race GRD4444 . . .£150.00
- Alloy radiator (side mounted) MT3104 . . . £255.00

Fan switches for use with GRD4442TDF, MT3104 can be used to switch any electric fan on or off. Electronic fan controller (RFC010) can be adjusted for different temperatures.

- Thermo switch 82-68° IM50100 £8.00
- Thermo switch 88-79° IM50120 £8.30
- Thermo switch 92-87° IM50200 £8.80
- Thermo switch 88-74° IM50250 £8.30
- Electronic fan controller, thread fitting M22 x 1.5 . RFC010£78.00

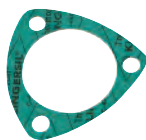

KLINGERSIL GASKET

These gaskets are manufactured from a modern high performance synthetic material that can withstand much higher temperatures (up to 400°F) and extreme pressures (up to 750psi) making them ideal for fast road and competition engines.

- Gasket thermostat housing updated GTG101X £1.25

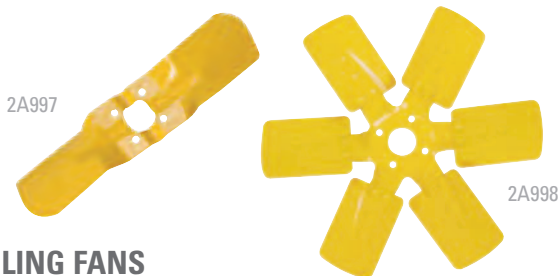

COOLING FANS

Fit a Special Tuning style two blade fan or for extra air flow use this 6 blade fan, as used on export Minis. Metal construction finished in yellow paint.

- 2 blade fan 2A997£34.40
- 6 blade fan 2A998£43.00

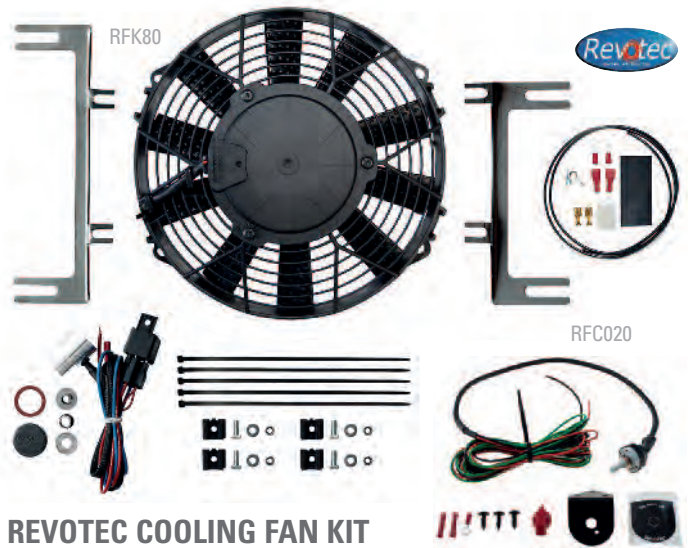

REVOTEC COOLING FAN KIT

Keeping the engine of your Mini running at its optimum temperature ensures you get the best performance and economy. These kits are designed to replace the standard original mechanical fan, reducing the load of the engine and noise and improving power and mpg.

Revotec have designed these kits using a special slim-line motor to fit neatly between the radiator and inner wing. Unlike other fan kits that use universal mounting systems, this kit fits using bespoke laser cut brackets that mount directly to the radiator cowling using existing mounting bolts. Not suitable for automatic models. A manual override switch is also available separately, enabling manual control of either On, Off or Automatic.

Kit includes: High efficiency fan assembly, electronic controller, bespoke brackets, hardware & wiring, & full instructions.

- Revotec fan kit RFK80 £203.90
- Manual override switch RFC020 £35.90





OIL COOLER KITS

These days we expect our cars to cope with high speeds for long periods of time, on motorways etc... These conditions stress the standard oil system of the Mini, as high engine speeds cause the oil to heat up and thin, reducing its viscosity and leading to a subsequent drop in oil pressure and possible premature engine wear. Oil cooler installation kits are available with either rubber or braided stainless steel hoses, the oil radiators themselves are sold separately. These are for non front mounted radiator models.

- Oil radiator 10 row ARO9807 **£66.00**
- Oil radiator 13 row ARA221 **£40.30**
- Oil radiator 13 row, Mocal ARO9809 **£84.00**
- Oil radiator 13 row heavy duty ARA221X **£134.00**
- Oil cooler kit rubber hose (to 1979) OCHK100 **£25.60**
- Oil cooler kit rubber hose (Clubman) (to 1979) OCHK101 **£42.00**
- Oil cooler kit stainless steel hose (to 1979) OCHK102 **£45.30**
- Oil cooler kit rubber hose (1979-84) OCHK103 **£15.00**
- Oil cooler kit stainless steel hose (1979-84) OCHK104 **£72.50**
- Oil cooler kit rubber hose (1985 on) OCHK105 **£50.70**
- Oil cooler kit stainless steel hose (1985 on) OCHK106 **£60.60**



SPIN-ON OIL FILTER ADAPTORS/CONVERSIONS

Fitting a spin-on filter adaptor makes changing the oil much easier and cleaner, it also prevents oil draining out of the filter giving better oil pressure on start up. Oil filters supplied separately.

- Spin-on oil filter conversion 948-1275cc GFK1001 **£75.60**
(For Tecalmit heads & Purolator heads, except casting number MIC90020).
- Oil filter - K&N Performance Gold 235-830 **£16.00**
- Oil filter - standard (for GFK1001 only) GFE166 **£2.76**
- Spin-on oil filter conversion & hose 948-1275cc. 235-875 **£53.15**
(This spin-on conversion is suitable for all models as it replaces the filter head and pipe assembly. Ideal if filter head or pipe is damaged or missing).
- Oil filter - K&N Performance Gold 235-830 **£16.00**
- Oil filter - standard (for 235-875 only) GFE173 **£5.05**

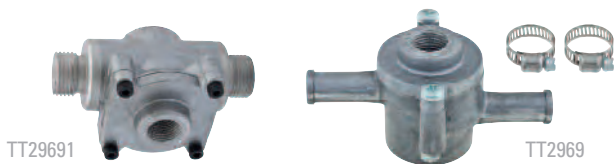

OIL TEMPERATURE GAUGE ADAPTOR

- If you want to fit an oil temperature gauge then use one of our in line adaptor.
- Push-on temperature 1/2" adaptor TT2969 **£49.80**
- Screw-in temperature 1/2" adaptor TT29691 **£81.10**



OIL COOLER THERMOSTATS

Use these thermostats to limit the flow of oil through the oil cooler until it has reached a temperature of 74 degrees Celsius.

The standard oil thermostat has push on connectors for use with 1/2" rubber hoses and comes with hose clips. It seals off the radiator completely until the oil is up to temperature. The full flow oil thermostat restricts flow to the radiator by allowing it to bypass through the thermostat until the oil is up to operating temperature. Use screw unions TT29602 to connect hoses to the full flow thermostat.

- Push-on standard oil thermostat TT2960 **£50.00**
- Screw-in full flow oil thermostat TT29602 **£148.50**
- Straight 1/2" unions (pair) TT9961 **£9.30**
(For use with screw in temperature adaptor and thermostat).



OIL PUMPS & VALVES

Good oil supply is a must, with the Mini's cornering capabilities oil starvation is a possibility all precautions should be taken. The oil pressure regulator allows you to adjust the preload on the oil pressure relief valve so you can alter the peak oil pressure. Please remember oil pumps require priming before fitment. Always remove spark plugs and spin engine over until oil pressure registers. See page A23 for K&N performance oil filters.

- 1 Oil pump turbo large capacity GLP110 **£41.20**
- 2 Oil release stainless steel valve ball 12H865X **£0.70**
(No sticking valves).
- 3 Oil valve spring (use with 12H865X) 6K853C **£1.20**
- 4 Adjustable oil pressure valve - black MT1112 **£16.50**
- 5 Adjustable oil pressure valve - blue MT1113 **£16.00**
- 6 Adjustable oil pressure valve - red MT1114 **£16.00**



OIL CATCH TANKS

A must for competition use to prevent oil spillage on the track. Manufactured from high grade aluminium and anodised for a smart, durable finish they feature 2 x 1/2" OD connectors for the breather hoses, level indicator, breather cap and drain plug. Available in 1 litre or 2 litre sizes. Mount using the rear flange to a suitable vertical panel in the engine bay.

- Oil catch tank 1lt TT2900 **£160.00**
- Oil catch tank 2lt TT2901 **£178.00**
- Breather hose - 1/2" ID (per metre) BAU5065M **£12.70**
- Hose clip (each) GHC11016 **£2.00**



CENTRAL OIL PICK UP

The standard oil pick up pipe is located to the RH side of the gearbox and oil surge during cornering can send the oil away from the pick up. This central oil pick up relocates the pick up point to the centre of the gearbox ensuring it is always submerged. Recommended if you are rebuilding the engine or gearbox.

CAHT54 **£30.00**



ANODISED DIPSTICK

These are beautifully crafted dip sticks which use two rubber 'O' rings to secure them into the engine, with a choice of either a red or blue anodised knob.

Dipstick with anodised knob - blue
GAC8457X **£10.80**
Dipstick with anodised knob - red
GAC8458X **£10.80**



MAGNETIC OIL TRAP

Designed to collect any metal particles at the top of the pick-up pipe, before they reach and destroy the oil pump. For all A series transverse engine and gearbox assemblies.

MS3313 **£31.40**



QUICK GEAR SHIFT KITS

Shorten the throw between gear changes... This kit improves feel and reduces gear lever travel resulting in a faster, slicker change. Available for either remote or rod type gearboxes, the kits include a modified gear lever, retainer and mounting hardware for simple installation.

Quick shift kit remote type
KAD1013218 **£92.00**
Quick shift kit rod type
MRAC1751 **£42.00**



STRAIGHT CUT GEAR KITS

CAJJ4014

The original design Special Tuning gear ratio set is available in three versions. Remote type and two rod type gear kits A series and A+. A series main shaft has 14mm nose into 1st motion shaft and A+ has 18mm nose on main shaft.

Straight cut gear kit remote type CAJJ4014 . . . **£520.00**
Straight cut gear kit rod A+ type CSTN77 . . . **£520.00**

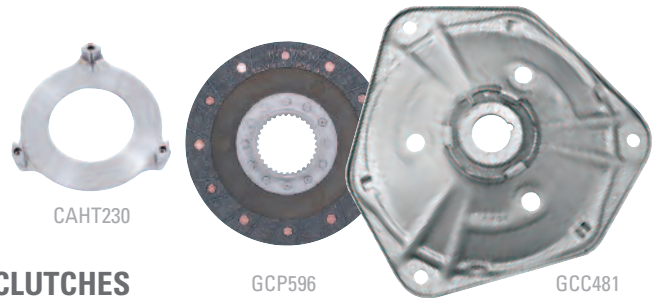

CLUTCHES

The much sought after 22G270 'S' clutch back plate has been out of production for many years, but has now been replaced with CAHT230. It was liked because of its strength. Although not steel, it was cast in a very high grade iron, the exact same material used here. This item is cast fairly light 3.56.lbs (Std 5.7lb), but can be lightened further if required, call for details.

Clutch pressure plate CAHT230 . . . **£100.00**
Clutch plate - road/rally GCP596 . . . **£131.00**
Clutch cover - road/rally GCC481 . . . **£39.00**
Clutch cover - rally/race GCC482 . . . **£37.80**



LIGHTWEIGHT STEEL FLYWHEELS

CAEG619

Using a lightweight steel flywheel has the same effect as lightening the car. Reducing the mass of rotating components in the engine helps the engine accelerate more easily leading to better acceleration of the car. These high quality steel flywheels are considerably lighter than the standard cast items and offer improved strength and a harder wearing clutch face. Their symmetrical design means they also reduce harmonic vibrations.

We offer flywheels in two specification; Roadlite and Racelite. Roadlite flywheels weigh in at 5kgs (11lbs), half the weight of a standard 1275cc. Our Racelite flywheels weigh in at just 3.63kgs (8lbs) for maximum weight saving in competition engines and are manufactured from EN8 grade steel.

Roadlite lightened flywheels
Diaphragm clutch with pre-engaged starter CAEG420 . . . **£165.00**
Racelite lightened flywheels
Diaphragm clutch with inertia starter CAEG619 . . . **£165.00**



GEARBOXES

These reconditioned gearboxes are available in either standard rod type or standard remote type. Both are subject to exchange.

Gearbox recon. standard rod type (exchange) . . . MT2101 . . . **£504.00**
Gearbox recon. standard remote type (exchange) . MT2102 . . . **£481.00**



HS2 AND HS4 TWIN CARBS

Increase the power from your Mini with one of these kits. They are designed to allow more fuel and air into the engine, whilst keeping that distinctive period look of a pair of classic SU carburettors. For the best results these carburettors require a sports exhaust system (at least). The twin carburettor kits include all the parts you need to fit them including manifold, heat shields and carburettors. (Air filters not included).

- HS2 twin carburettor kit FZX3052 . . . £759.20
- HS2 twin carburettors only AUD662T . . £619.80
- HS4 twin carburettor kit FZX3054 . . . £795.60



DASHPOT COVERS FOR SU CARBURETTORS

Polished or anodised dashpot covers are an easy way to brighten the engine bay.

- HS2 dashpot cover - silver SFR22£11.00
- HS4/6 dashpot cover - silver SFR23£15.50
- HS4/6 dashpot cover - anodised blue SFR23B£18.10
- HS4/6 dashpot cover - anodised red SFR23R£18.10
- HIF carburettor dashpot cover - silver SFR24£15.50

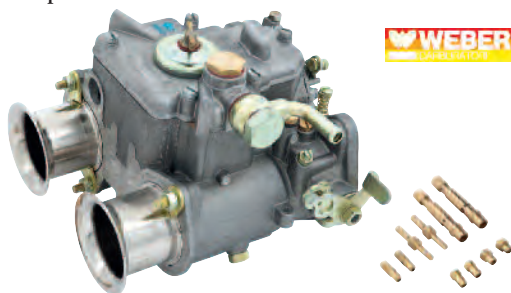

WEBER CARBURETTOR 1275CC

This Weber carburettor is fitted with the basic jets and chokes that are correct for fast road applications, although these will still require fine tuning when on the car to receive maximum performance and economy.

- 40 DCOE Weber carburettor - fast road TT29343308 .£504.00

HIGH TORQUE STARTER MOTOR

These high torque starter motors offer increased torque and are a straight replacement for the original, however only weighs 3.9kg. The huge increase in cranking power is essential for engines with increased compression ratios.

- High torque starter motor inertia type GXE4404X . . £222.80
- High torque starter motor pre-engaged type . . . GXE4527X . . £222.80

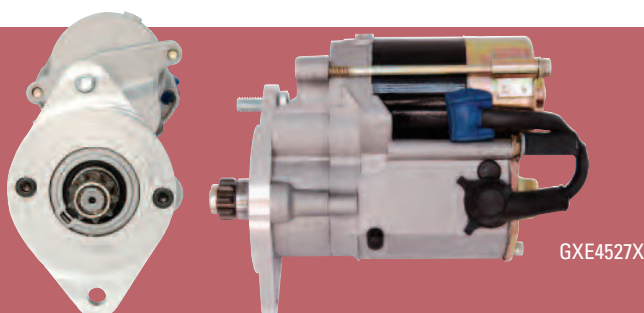

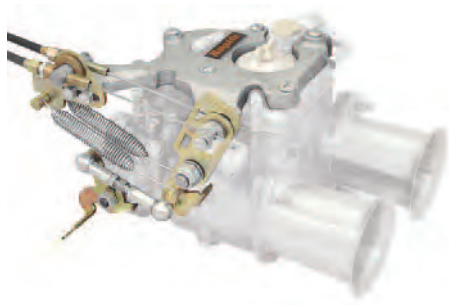

Carburettor not included

WEBER DCOE THROTTLE LINKAGES - MANGOLETSI

Mangoletsi is a long established name in the performance tuning industry, and a leading manufacturer of competition inlet manifolds & throttle linkages. We now offer Mangoletsi's new range of DCOE 'sliding set-up' throttle linkages.

This new simple design features a cast bracket which fits over the top of the carburettor, holding the linkage neatly to the side of the carburettor. This unique design has an ultra-low profile - the highest point of the linkage is only 10mm higher than the carburettor, ideal if clearance is limited. Each kit is suitable for single or twin carburettor set-ups for in-line engines.

The unique design also gives a wide range of throttle adjustment. Cable travel and spring tension can be adjusted independently. The adjuster can be set to give the desired cable travel, the spring tension can then be set to give the correct throttle shut off. This allows the throttle feel to be fine tuned to the driver's requirements.

- Throttle linkage DCOE - twin cable LP42451**£107.90**
- Throttle linkage DCOE - single cable LP42411**£94.90**

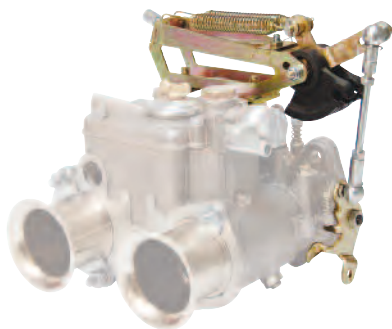

Carburettor not included

WEBER DCOE THROTTLE LINKAGES - WEBCON

Webcon linkages have been designed to offer a variety of fitting layouts to give flexibility of installation.

The lightweight construction is manufactured from steel and zinc-plated to match existing components on the carburettor, giving an OEM look.

Available in top or bottom mount for single or twin cables. Cables can be routed from either side and the linkage offers adjustment for cable movement from 22-40mm. The outer cable is retained in the adjuster whilst the inner cable fits to a quadrant cam, featuring sintered bronze bearings, giving a smooth linear action. High quality 8mm ball joints, with an opposed threaded rod, are used on the linkage for ease of adjustment and set up.

Single cable kits use the existing throttle cable whilst the twin cable kits include a pair of nylon lined cables and an adaptor block to convert the throttle pedal.

- T/linkage DCOE - top mount/single cable LP4100**£109.00**
- T/linkage DCOE - top mount/twin cable LP4101**£118.00**
- T/linkage DCOE - bottom mount/single cable LP4102**£109.00**
- T/linkage DCOE - bottom mount/twin cable LP4103**£118.00**

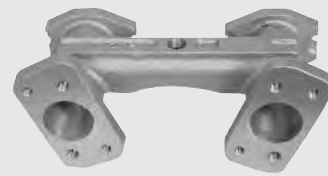

TWIN SU ALLOY INLET MANIFOLD

This intake manifold is for twin SU's (HS2 or HS4).

- Twin SU alloy inlet manifold LP4012**£171.00**



C-AEG489

TWIN SU ALLOY INLET MANIFOLD

This intake manifold is for twin SU's (HS4 or HS6) produced to the original Abingdon ST design. The throttle bracket is suitable for twin SU manifolds.

- Twin SU alloy inlet manifold C-AEG489**£78.00**
- Twin SU throttle bracket AEG349**£6.60**
- Screw for throttle bracket SH504041**£0.42**



WEBER INLET MANIFOLDS

Single Weber/Dellorto inlet manifold 10cm (4 inch) long. This manifold will require bulkhead modifications.

- Single Weber/Dellorto 10cm inlet manifold TT10850**£161.50**

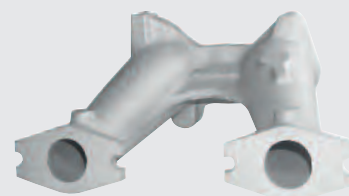

Single Weber/Dellorto inlet manifold 15cm (6 inch) long. Supplied complete with direct acting throttle linkage. Will require bulkhead modifications.

- Single Weber/Dellorto 15cm inlet manifold TWM0071**£353.00**



HIGH FLOW ALLOY INLET MANIFOLD

High flow alloy inlet for 1.75" carburettors, the larger ports make this manifold ideal for large capacity engines e.g. 1380cc.

- High flow alloy inlet manifold MT3603**£59.40**
- Blanking plug (if brake servo not used) ADP210**£6.24**
- Sealing washer AED172**£1.15**



CSI-IGNITION DISTRIBUTORS

CSI-Ignition distributors offer a fully electronic ignition system built into the correct type of Lucas distributor housing to suit your car, keeping the original appearance in the engine bay. You can only tell the difference when you remove the distributor cap!

Gone are the points and condenser and mechanical advance mechanism, all replaced with a high quality electronic ignition system manufactured using military specification components for durability and reliability.

These distributors are maintenance free (no points to adjust), and offer the benefits of, easier starting and smoother running, more torque and power, reduced fuel consumption and emissions.



See page A22 for more information

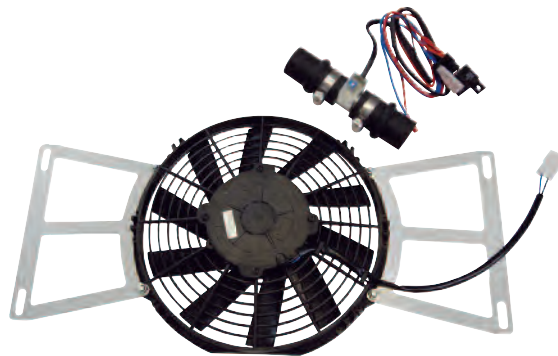

REVOTEC COOLING FAN KITS

Keeping your engine running at its optimum temperature will ensure the best performance and economy.

Revotec and Moss Europe have co-designed these high quality bespoke fan kits using the latest high efficiency fans with adjustable electronic controllers. These kits are designed to replace the standard original mechanical fan, reducing the load on the engine, noise and improving both power and mpg.

Unlike other fan kits that use universal mounting systems, these kits fit using bespoke laser cut brackets that mount directly to the radiator cowling using existing mounting bolts.



See page A09 for more information



PERFORMANCE EXHAUST MANIFOLD

This highly polished stainless steel manifold is designed to work with our range of Fletcher performance exhausts, page A18. Made from T304 stainless steel. The finish and welding on this product is just about as good as it gets.

- LCB stainless steel non-catalyst models MT6506 . . . £223.00
- Blanking plug for lambda sensor (as required) . . . WPE1104X . . . £4.24

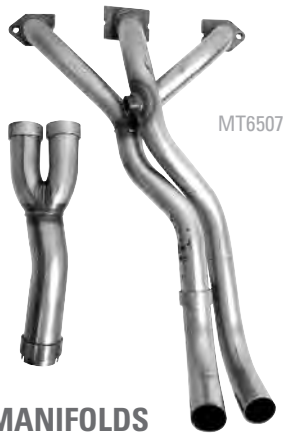

PRO FLO LCB MANIFOLDS

New to the market, these well designed Pro Flo manifolds feature a larger secondary pipe than usual. Perfect for performance tuning on fast road cars.

- Pro Flo exhaust manifold injection models MT6507 . . . £102.00
- Pro Flo exhaust manifold carburettor models . . . MT6508 . . . £102.00
- Blanking plug for lambda sensor (as required) . . . WPE1104X . . . £4.24

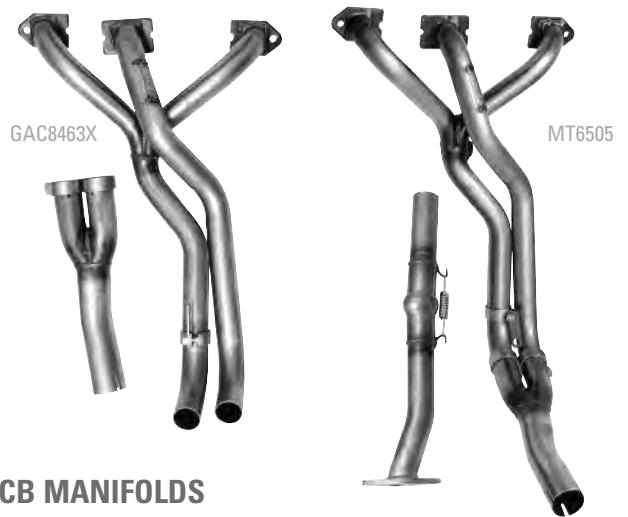

LCB MANIFOLDS

The medium bore long centre branch manifold (LCB) is probably the most popular for the Mini in production today. Suitable for engines up to 1380cc this is the first step to greater performance. This Manifold long centre branch exhaust manifold is for applications up to 100bhp and includes primary pipes and Y piece with clamps.

- LCB mild steel manifold (carbs. to 100bhp) GAC8463X . . . £98.50
- LCB mild steel manifold (injection with cat.) . . . MT6505 . . . £156.00
- Blanking plug for lambda sensor (as required) . . . WPE1104X . . . £4.24
- LCB exhaust manifold Y piece (as required) GAC84631 . . . £49.90



FREEFLOW MANIFOLD

This freeflow exhaust manifold is specifically manufactured in mild steel for the Cooper model.

- Freeflow mild steel manifold MT6101 . . . £103.50

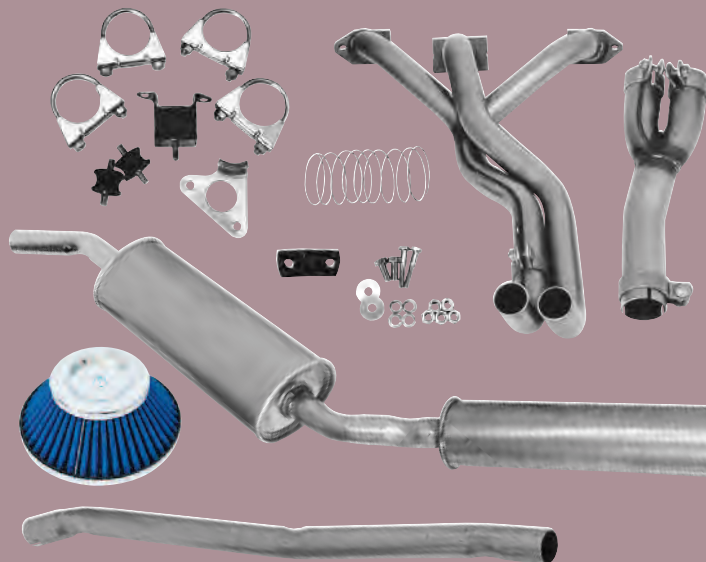

STAGE ONE TUNING KITS

MTK1275

Our stage one tuning kits are available for both the 998cc & 1275cc carburettor Classic Mini models. When developing the tuning kits, only tried and tested high quality components that would actually improve the Mini's performance were selected.

For example; the Moss kit uses the legendary RC40 exhaust system which not only adds bhp but also produces a satisfying sporty tone, while remaining suitable for all types of driving.

These comprehensive kits contain everything required for fitting to a standard car, including a new needle and spring for the carburettor.

- Stage one tuning kit (998, 1071, 1098cc) MTK998 . . . £235.40
- Stage one tuning kit (1275cc) MTK1275 . . . £270.00



EXHAUST HEAT INSULATION

Wrapping a tubular manifold will keep engine bay heat to a minimum, reducing engine bay temperatures by up to 70%. This will benefit power in two ways; firstly it will reduce the temperature of the air going into the engine; secondly, it improves the effectiveness of the manifold by increasing gas speed due to lower gas density, increasing the scavenging effect.

This race proven, asbestos free, product from Thermo-Tec is manufactured from Silica based yarns and is unaffected by oil or water, and can withstand temperatures of up to 1000°C. As a guide to coverage a 2" x 50' roll will cover approximately 13ft of 2" pipe. Manifold wrap is supplied in a variety of sizes, see below for details. Use Snap Straps to hold the wrap in position.

Roll size (W x L)	Natural	Black
1" x 15' roll	GAC150 £13.10	GAC151 £15.20
2" x 15' roll	GAC152 £21.60	GAC153 £23.80
1" x 50' roll	GAC154 £38.20	GAC155 £42.40
2" x 50' roll	GAC156 £65.00	GAC157 £71.70

Manifold blanket

Using a manifold blanket provides excellent heat retention for exhaust manifolds and can be easily installed to both cast iron and tubular manifolds. Manifold blanket should be retained with Snap Straps.

Manifold blanket 4-6 cylinder	GAC182	£109.60
Manifold blanket V8 2 piece	GAC183	£116.60

Snap Straps

Use Snap Straps to hold the wrap or blanket in position.

Snap Strap kit 8 x 9" & 4 x 18" lengths	GAC172	£34.90
Snap Strap kit 6 x 9" & 4 x 18" lengths	GAC173	£30.50
Snap Strap kit 12 x 9" lengths	GAC174	£32.80
Snap Strap kit 6 x 18" lengths	GAC175	£21.60
Snap Strap kit 4 x 14" lengths	GAC176	£10.90

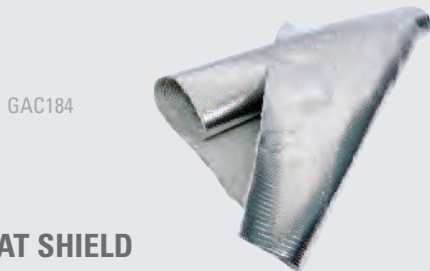

HEAT SHIELD

Radiant heat coming through the floors and bulkhead can make the cockpit of your Mini a hot place to be. Insulating the floors and bulkhead not only keeps the heat out but it can also prevent damage to carpets, paintwork and interior fittings where exhaust pipes, silencers and catalytic converters are in close proximity to the panelwork.

Exhaust heat shield can be used on the underside of the floors where the exhaust runs close to the floor particularly above silencers and catalytic converters. It effectively reflects 90% of the radiant heat from exhausts and can withstand temperatures up to 1000°C. The general purpose material can be used to cover bulkheads and floors to keep general heat transfer to the cockpit to a minimum. It can also be used to wrap and cover components in the engine bay to prevent heat damage.

Exhaust heat shield 40" x 24"	GAC184	£86.80
General heat shield 1m x 1m	GAC185	£79.10
High temperature adhesive	GAC9908X	£11.00



TWIN SU STAINLESS STEEL HEAT SHIELDS

These new mirror finish stainless steel heat shields not only look great they also redirect some of the heat from the exhaust manifold.

Twin SU stainless steel heat shields for HS2 MST018	£22.70
Twin SU stainless steel heat shields for HS4/6 MST019	£22.70



LARGE PORT MANIFOLD GASKET

The large ports on this gasket allow fitment of performance manifolds with larger primary pipes.

Manifold to cylinder head gasket TMG10836	£4.44
---	-------



REAR SILENCER FITTINGS

Early Minis used rubber blocks to hang the original exhausts from. The Play Mini range uses the later type of hook brackets and rubber hangers. These fitting kits contain all components, including the hanger conversion brackets, to allow easy installation. Simply use hanging rubbers for late cars.

Fitting kit side exit WPE3003X	£42.00
Fitting kit centre exit WPE3002X	£27.60
Subframe hanger bracket front PME48	£15.40
Subframe hanger bracket rear PME49	£15.20
Hanging rubber GEX7661	£3.55
Catalytic converter gasket GEX7761	£1.92



STEPPED ADAPTOR

This useful adaptor allows the fitting of any back box to a standard system. Simply cut the existing system where appropriate.

Stepped adaptor 1.25" to 2" PME43X	£21.00
--	--------



MIKALOR EXHAUST CLAMPS

These high quality stainless steel clamps are ideal for use on your Mini exhaust. The strap design and clamp mechanism ensure that even clamping pressure is applied all round the joint.

Mikalor clamp 1 1/2" (37-40mm) TT9930S	£2.23
Mikalor clamp 1 5/8" (40-43mm) TT9931S	£2.53
Mikalor clamp 1 3/4" (43-47mm) TT9932S	£3.49
Mikalor clamp 1 7/8" (47-51mm) TT9933S	£2.63
Mikalor clamp 2" (51-55mm) TT9934S	£2.63
Mikalor clamp 2 1/4" (55-59mm) TT9936S	£2.63
Mikalor clamp 2 1/2" (63-68mm) TT9938S	£3.00

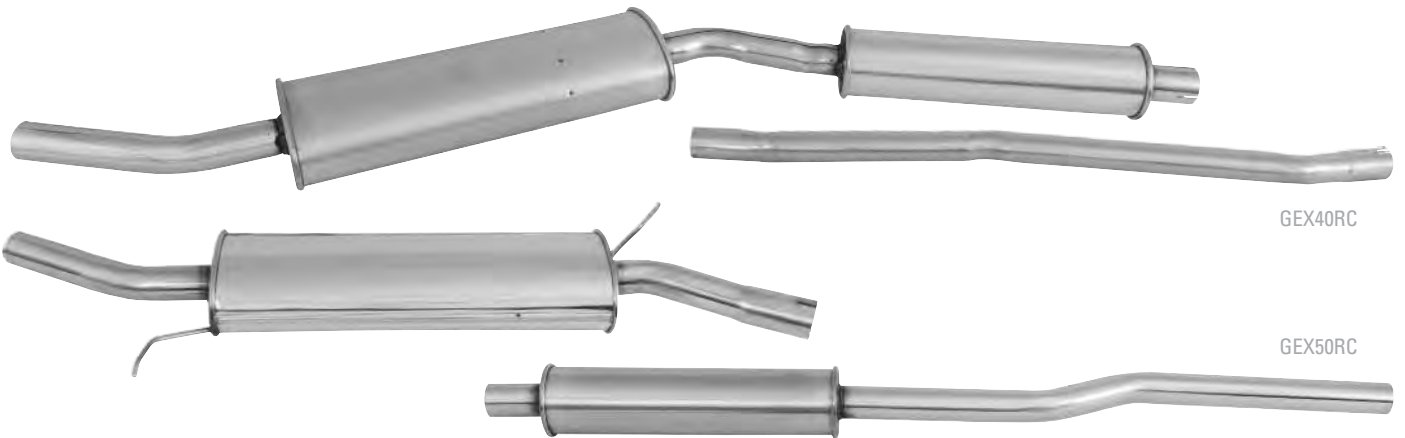

GEX40RC

GEX50RC

RC40 & RC50 EXHAUST SYSTEMS

The RC40 and the stainless steel version, the RC50, are renowned as 'the systems' to have when improving the Mini performance. With tuned silencer boxes, and computer optimised tube lengths the system can release more power especially when combined with the LCB manifold.

We also stock just the rear RC40 silencer fitted with a pipe to bolt straight on to the catalyst for cars built late 1991-on SPI & MPi (not early carb cooper). The intermediate pipes are the correct length and shape to fit directly to the Cooper Freeflow exhaust manifold but will require a short length of the front part of the pipe to be cut off to fit an LCB exhaust manifold.

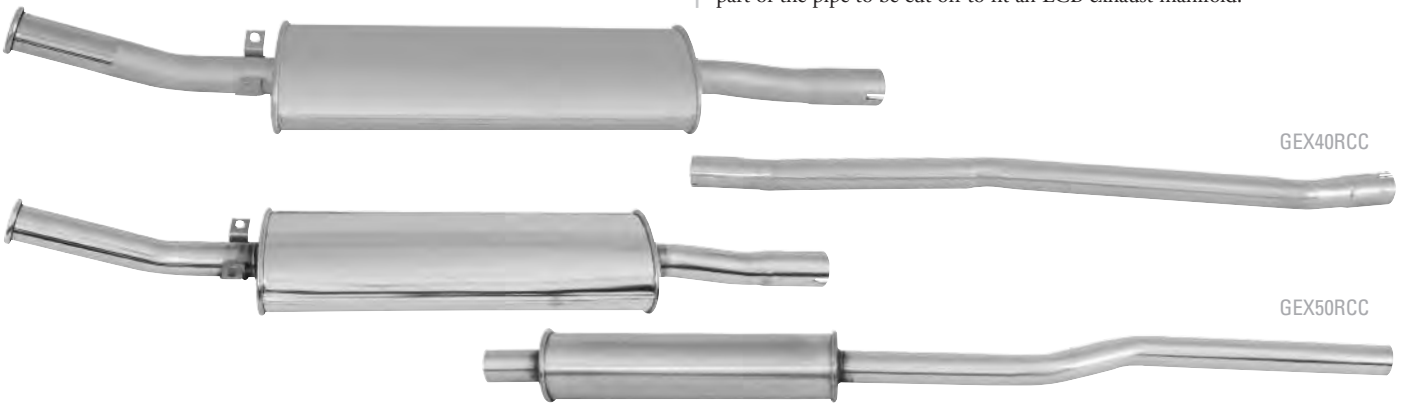

GEX40RCC

GEX50RCC

RC40 and RC50 Exhaust Systems - Carburettor Models without Catalyst

(All kits include intermediate pipe).

- RC40 system, side exit single box, mild steelGEX40RCS . . .£49.80
- RC40 system, side exit twin box, mild steelGEX40RC . . .£60.76

- RC50 system, side exit twin box, stainless steel . . GEX50RC . . £228.00
- RC40 system, centre exit single box, mild steel . . GEX40RCC . . £82.00
- RC50 system, centre exit single box, stainless steel GEX50RCC . £234.00
- RC40 early type exhaust fitting kitGEX40FK . . .£12.50

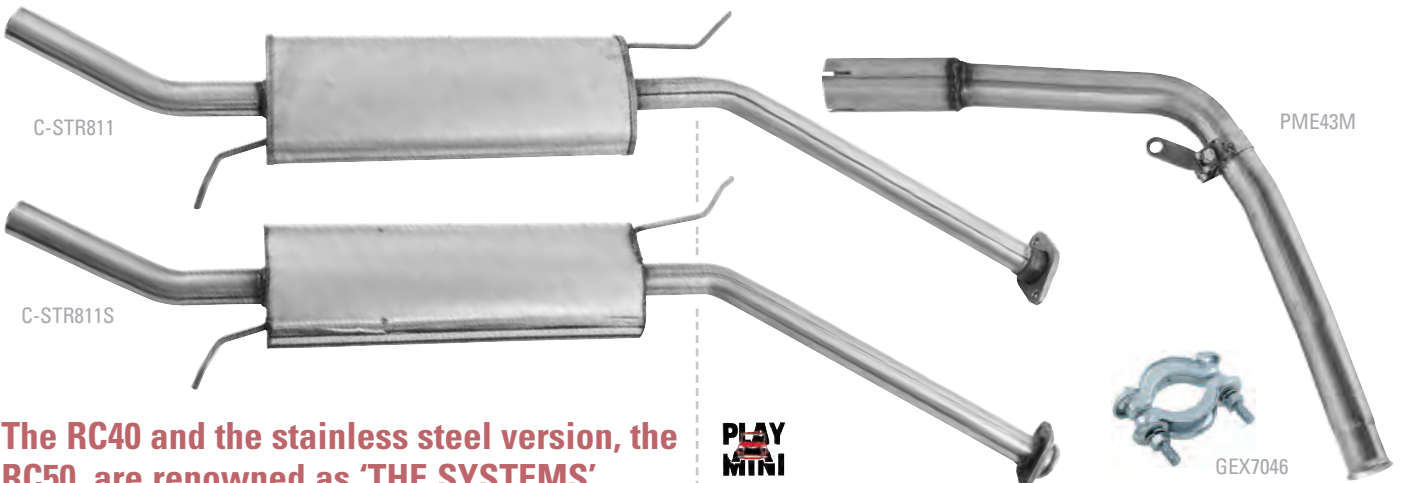

C-STR811

C-STR811S

PME43M

GEX7046

The RC40 and the stainless steel version, the RC50, are renowned as 'THE SYSTEMS'...



PLAY MINI MAGIC PIPE

RC40 Exhaust Systems - Carburettor and Injection Catalyst Models (1991-On)*
(*Not early Cooper carb models).

- Silencer Assembly, RC40, catalyst back, mild steel C-STR811£80.00
- Silencer Assembly, RC40, catalyst back, stainless steel .C-STR811S . £130.00
- Catalyst gasketGEX7761 £1.92
- Exhaust hanger, rubberGEX7661 £3.55

For those of you who don't want to fit an LCB manifold to the car this pipe is designed to fit to the original cast manifold but will enable you to fit most of our systems to your car. **Please note this pipe is for carb models only.**

- Down pipe (Magic Pipe), stainless steel PME43M . . . £53.80
- Manifold clamp GEX7046 £2.53
- Exhaust clamp 2" GEX9009 £1.00

PERFORMANCE EXHAUSTS



Many Classic Mini owners like the rumble from a performance exhaust system. There are many options available and it can be confusing trying to work out what piece fits with what...

To help with the selection of our performance exhaust systems, we have added these simple layouts for carburettor and injection models to make things a little clearer. It's as easy as 1, 2, 3, (4, 5)... The layout starts at the front of the car with the manifold working its way back.

The selected exhaust system pieces shown here are known to fit together so that you can choose the pieces you want and avoid any problems with fitment.

If you're still unsure about what you need please call us and we will be happy to help.



CARBURETTOR MODELS WITHOUT CATALYST

LCB manifolds



LCB stainless steel manifold
MT6506 £223.00

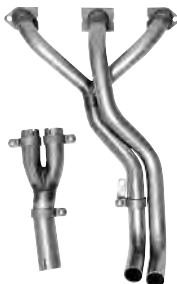

Pro Flo LCB mild steel manifold
MT6508 £102.00

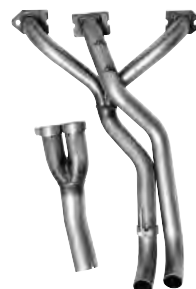

LCB mild steel manifold
GAC8463X £98.50

Link pipe



Fletcher universal link pipe
FES100 £68.80

Rear silencers



Fletcher side exit single pipe
FES200 £155.00



Fletcher DTM centre exit pipe
FES201 £198.00



Play Mini centre exit single pipe
PME41 £154.00



Play Mini centre exit twin pipe
PME42 £162.20



INJECTION MODELS WITH CATALYST

LCB manifolds

1

LCB mild steel manifold
MT6505 £156.00



Pro Flo LCB mild steel manifold
MT6507 £102.00

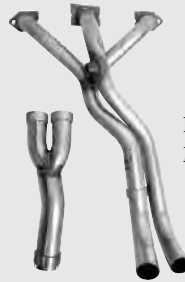

Front link pipe (LCB to catalyst)

2

Fletcher front link pipe
FES101 £35.90



Play Mini front link pipe
PME51 £41.20



Catalyst replacement pipe

3

Note: You will only require the replacement pipe (FES103) if you are replacing the catalyst. If you are retaining the catalyst, see our restoration parts section for catalyst options.

Fletcher cat replacement pipe
FES103 £31.60



Rear link pipes (catalyst to silencer)

4

Fletcher rear link pipe
FES102 £39.30



Rear silencers

5



Fletcher side exit single pipe
FES200 £155.00



Fletcher DTM centre exit pipe
FES201 £198.00



Play Mini centre exit single pipe
PME41 £154.00



Play Mini centre exit twin pipe
PME42 £162.20



NGK SPARK PLUGS & PLUG CAPS



Changing the spark plugs regularly ensures the engine performs well. NGK are renowned for making performance plugs giving a strong spark and long life.

Spark plugs

Spark plug (all eng. cc) - standard tune BP6ES £3.30
 Resistor spark plug (all eng. cc) - standard tune BPR6ES £5.15
 (For radio suppression).

Spark plug - tuned road BP7ES £3.79
 Spark plug gold palladium electrode - tuned road BPR7EIX £14.15

Plug caps

Straight plug cap, red (each) NSB5 £3.68
 Straight plug cap, black (each) NSB5BLK £3.58
 60° plug cap, red (each) NYB5 £3.68
 60° plug cap, black (each) NYB5BLK £3.58
 90° plug cap, red (each) NLB5 £5.40
 90° plug cap, black (each) NLB5BLK £3.00
 Push-in connector distributor cap & coil (each) GCL1110 £1.66

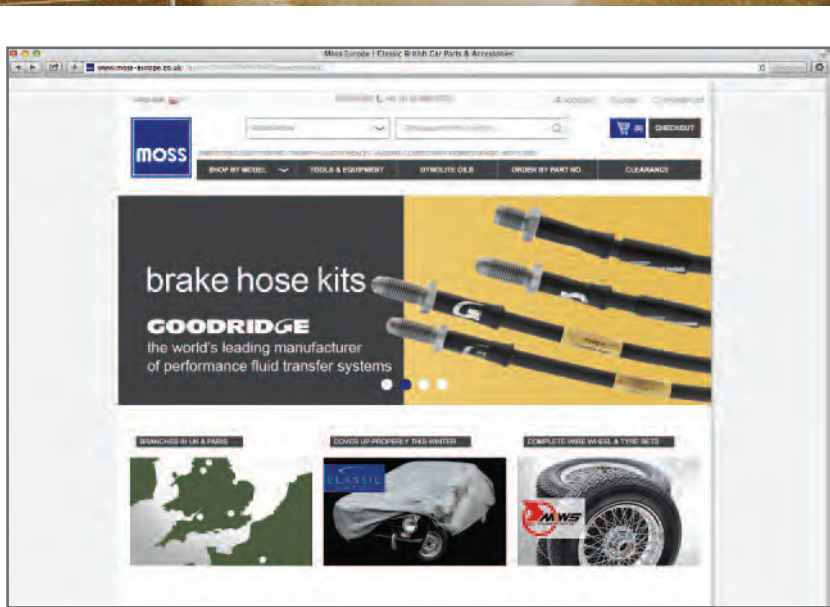

HARNESS THE POWER

moss-europe.co.uk *"Available to you whenever you want!"*

Have easy access to everything in this catalogue, including multiple product images and our detailed schematics. Benefit from the latest parts information, availability and pricing.

information about our sale offers and clearance sale items. All this and more... available on your computer, smartphone, ipad and tablet.

Furthermore, you will have up to the minute

Visit moss-europe.co.uk and harness the power.



17% off
 Autumn Sale | ends
 Monday 17th October



COIL CLAMP & COVER

Brighten up your engine bay with our stainless steel coil clamp and covers for standard coils only.

- Stainless steel coil clamp onlyGAC8470X £8.65
- Stainless steel coil clamp & coil cover setGAC8470CC . £13.30

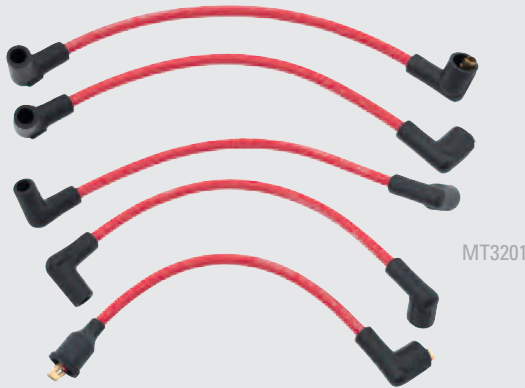

SILICONE HT LEADS

These HT lead sets are made from high quality silicone. Offering high conductor performance with awesome looks.

- Performance HT leads 8mm - blue MT3200 £14.70
- Performance HT leads 8mm - red MT3201 £14.70



COBALT PERFORMANCE HT LEAD SETS

Get the spark from your coil with silicone HT leads that are designed to perform. These Cobalt leads use a high performance conductor to transmit greater energy to the spark plug creating a stronger spark for improved combustion. They also feature multi-layer reinforcing and insulation with protective silicone outer sleeve and terminal boots for improved reliability.

Engines with a Lucas 25D distributor require a top entry 'push in' type distributor cap GDC103.

- Cobalt silicone lead set (848-1275cc)TMG10872 . . £22.45
- Top entry push in distributor cap (848-1275cc) . GDC103 £5.92



HT LEAD NUMBERING SET

Keep track of which HT lead is which with a set of four numbered sleeves.

- HT lead numbering set 4 cylinder CRST255 £4.20



SPORTS COILS

Sports coils are designed to improve ignition performance. They give more reliable starting power and greater performance at high revs thanks to the 40,000 volt output.

Don't forget to renew your plugs and leads to optimise the power. Only use the ballast type coil if your car is fitted with a ballast resistor in the wiring. Please check before ordering. Your HT lead into the coil will need to be the push-in type, use GCL1110 to convert the lead.

- Sports coil non-ballast type TT2981 £21.50
- Sports coil ballast type TT29812 £21.50
- Ignition lead end kitGCL1110 £1.66



COMPETITION HT LEAD

If you want a performance HT lead with the correct period look then this 'bumblebee' lead is a must. As per the original 'Lucas' type it features a high conductivity copper core with a yellow insulator featuring a black stripe. Alternatively, use the standard black lead for an 'OE' look. We recommend you assemble leads with NGK suppressed plug caps.

- Bumblebee HT lead (per metre)TT2982M £6.14
- HT lead (per metre) - black AAA5981M £2.60



ELECTRONIC DISTRIBUTOR

This electronic distributor was originally fitted to all standard Cooper 1275cc carb models. It can also be used on any A+ 1275cc car using a carburettor! No points or condenser to worry about either. Also available is the plug & lead to connect to the existing wiring.

- Electronic distributor & lead kit 1275cc AUU1536K . . £117.50
- Electronic distributor 1275cc (carb models)AUU1536 £80.00
- Plug & lead 54966877 £6.76
- CapGDC156 £3.08
- Rotor armG.A2143 £2.86

Lumenition



CEK150

LUMENITION IGNITION

Lumenition electronic ignition kits are well known as being among the finest after-market electronic ignition systems available. This system basically replaces both the contact points and condenser with an optical switch and power module. The power module is an electronic device that receives a pulse from the optical trigger which switches the coil. The trigger eliminates contact bounce, arcing, mechanical wear and spark scatter, reducing maintenance and increasing reliability. With minimal wiring and modifications this kit is very discreet. **Note: Installation of a power module requires a distributor fitting kit.**

A performance ignition kit is available, it includes a power module and a high output coil. The microcircuit control of the coil current gives optimum performance across high engine speed ensuring maximum spark energy at the coil. A fitting kit, to suit the distributor application, is also required. Positive earth wiring instructions are available from your branch. Check your distributor type before ordering the fitting kit as many cars have non-original distributors fitted. The identification number is cast on the distributor body.

Performance ignition kit

Supplied with high energy coil and performance power module. Requires fitting kit to suit distributor.

- Performance ignition kit CEK150 **£280.80**
- Coil replacement for CEK150 CEC **£62.40**

Power module and performance ignition coil

- Power module PMA50 **£211.70**
- Performance ignition coil MegaSpark 4 LMS4 **£42.80**

Mounting bracket and fitting kits

Designed to mount the power module neatly using coil bracket screws. Use these fitting kits with your choice of ignition kit.

- Power module mounting bracket (all modules) . . MK006 **£12.30**
- Lucas 22D4 25D4 distributors LFK116 **£19.50**
- Lucas 43/45D4 distributors LFK117 **£19.50**
- Lucas 45DE4 electronic distributors LFK109 **£19.50**
- Lucas 59D distributors LFK117 **£19.50**

PERTRONIX



222-405

PERTRONIX IGNITION

These self contained electronic ignition units offer a simple alternative to traditional points and condenser arrangement. Easily installed with no external control boxes to mount and only two wires to hook up and no permanent modifications involved. The unit uses a sealed Hall Effect sensor that is impervious to dirt, dust, moisture, or vibration and retains standard advance curve. Unaffected by distributor shaft wear, maintains firing accuracy to within 1/4°, reduces spark scatter over the rpm range. One year warranty.

- Pertronix ignition Lucas 23-24-25D4 222-405 **£140.04**
- Pertronix ignition Lucas 45D4 222-435 **£140.04**
- Pertronix ignition Lucas 59D4 222-546 **£165.00**

CSI-IGNITION DISTRIBUTORS

CSI-Ignition distributors offer a fully electronic ignition system built into the correct type of Lucas distributor housing to suit your car, keeping the original appearance in the engine bay. You can only tell the difference when you remove the distributor cap! Gone are the points and condenser and mechanical advance mechanism, all replaced with a high quality electronic ignition system manufactured using military specification components for durability and reliability. These distributors are maintenance free (no points to adjust), and offer the benefits of, easier starting & smoother running, more torque & power, reduced fuel consumption & emissions. They also eliminate the weaknesses of mechanical timing advance and problems such as points bounce ensuring correct ignition timing throughout the rev range.



CSD8014671

“The new range of CSI-Ignition distributors is a breakthrough for classic car ignition systems”.

Each CSI-Ignition distributor features 16 easily switchable, optimised ignition curves to allow timing adjustment to suit your car’s engine and fuel specifications. Alternative advance curves can be selected to suit your engine’s state of tune making them ideal for modified engines. Curves are easily selected using a screwdriver in a rotary switch, with a bright flashing LED indicator to show the selected curve all concealed underneath the distributor cap. The distributors are also available with an electronic immobiliser system to prevent unwanted starting of the engine.

We offer a wide range of CSI-Ignition distributors for a variety of applications. They are available Optimised with vacuum advance to suit road or uprated cars running on SU carburettors, or tuned without vacuum advance for cars running Weber type carburettors. Please note: Some units may only be available to order. More details are available on our website, search for CSI-Ignition Distributor.

Distributors for pre A+ engines - 850cc-1275cc, inc. Coopers (Lucas 25D)

- Optimised 25D4 positive earth CSD8014571 **£250.00**
- Tuned 23D4 positive earth CSD8023571 **£250.00**
- Optimised 25D4 negative earth CSD8014581 **£250.00**
- Tuned 23D4 negative earth CSD8023581 **£250.00**
- Optimised with immobiliser 25D4 positive earth . . CSD8014671 **£410.00**
- Tuned with immobiliser 23D4 positive earth . . . CSD8023671 **£410.00**
- Optimised with immobiliser 25D4 negative earth . CSD8014681 **£410.00**
- Tuned with immobiliser 23D4 negative earth . . . CSD8023681 **£410.00**

Distributors Pre A+ engines - 850cc-1275cc (Lucas 45D)

- Optimised 45D4 CSD8014582 **£250.00**
- Tuned 43D4 CSD8023582 **£250.00**
- Optimised with immobiliser 45D4 CSD8014682 **£410.00**
- Tuned with immobiliser 43D4 CSD8023682 **£410.00**

Distributors A+ engines - 850cc-1275cc (Lucas 59D)

- Optimised 59D4 CSD8014583 **£250.00**
- Tuned 59D4 CSD8023583 **£250.00**
- Optimised with immobiliser 59D4 CSD8014683 **£410.00**
- Tuned with immobiliser 59D4 CSD8023683 **£410.00**

CSI distributors require a coil with minimum resistance of 2.5 ohms. We recommend our sports coil TT2981 3 ohms. Bypass the ballast resistor if fitted.

- Sport coil (3 ohms) TT2981 **£21.50**



BREATHER FILTERS



Performance engine breather filters are an alternative to running pipes from the clutch housing and timing cover breathers. Short stack filters are available in three colours and simply push onto the breather. Just remember to block off the other on the carb or air filter end where the original pipe was attached.

- 1 Breather filter 12mm inlet - blue MT1200 £6.20
- 2 Breather filter 12mm inlet - chrome MT1201 £6.20
- 3 Breather filter 12mm inlet - red MT1202 £6.20

K&N breather filters

- 4 Engine inlet breather filter KN62-1010 . . . £29.20
- 5 Crank breather filter KN62-1330 . . . £24.00



K&N PERFORMANCE FILTERS (AIR & OIL)



K&N air filters are probably the most efficient way of ensuring clean, dirt free air for the engine without compromising performance. We supply a tapered filter to fit as a replacement to the standard filter and case assembly within the confines of the engine bay. For those who wish to have the increase in cleaning and air flow efficiency without the increased noise, we offer a replacement filter element to fit directly into the standard filter casing.

- Twin HS2 pancake filter (850-1275cc to 1974) . .KN56-1630A £125.00
- Twin HS4 K&N filter assemblyKN56-9128 . . .£87.50
- Tapered HS4 K&N filter (1000cc) KN56-9320 . .£102.00
- Tapered HIF44 K&N filter (Cooper 1300cc) . . KN56-9330 . .£110.20
- Tapered HS6 K&N filterKN56-9327 . .£110.00

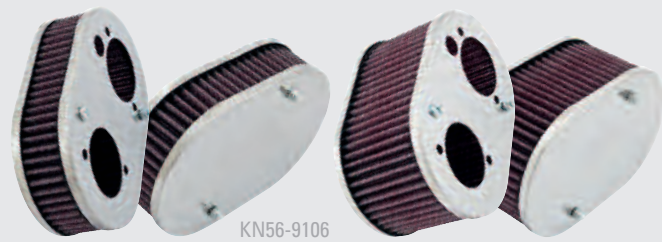

K&N air filters (180mm x 120mm) for Weber carburettors

- DCOE fitting 45mm (1 3/4" deep) KN56-1270 . .£100.00
(Not suitable for ram pipes).
- DCOE fitting 45mm (1 3/4" deep) KN56-9106 . .£99.80
- DCOE fitting 63mm (2 1/2" deep) KN56-9104 . .£98.70
- DCOE fitting 83mm (3 1/4" deep) KN56-9265 . .£92.80



K&N air filter kit

- SPI performance filter kitKN57-0082 . .£93.20
(Complete with cold air ducting kit).



K&N replacement elements

- HS4 & HIF38 replacement element* (non inj) . .KNE2601 £46.20
- SPI & MPI replacement element* (injection) . . . KNE9172 £48.60
(*Fits into standard case).



K&N Performance Gold® oil filter

These K&N oil filters feature a number of improvements over standard oil filters, like higher flow rates, improved filtration, anti-drain valve and a nut for ease of removal. Originally developed by K&N for race applications these high quality filters are becoming a favourite among consumers who want only the best products for their cars. See page A10 for uprated oil pump.

- K&N Performance Gold® oil filter (A series)235-830£16.00

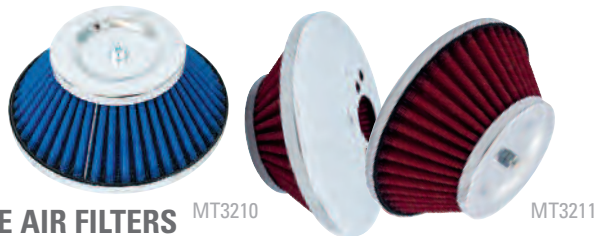

CONE AIR FILTERS

Performance cone air filters help improve the air flow to the carburettor. This type of air filter can be taken off, cleaned, re-oiled then put back on time and time again. Well made and looks great with the chrome finish.

- Cone air filter HIF44 MT3210 £46.30
- Cone air filter HS4 MT3211 £32.00



RAM PIPES Ram pipes for Weber and Dellorto carbs

These ram pipes are designed to improve air flow into the Weber and Dellorto carburettors, ideal for use with or without filters, space permitting.

- 1 40 DCOE/DHLA 16mm ram pipeKNSS1640 . . . £35.70
- 2 40 DCOE/DHLA 26mm ram pipeKNSS2640 . . . £35.70
- 3 40 DCOE/DHLA 39mm ram pipeKNSS3940 . . . £35.70
- 45 DCOE/DHLA 16mm ram pipeKNSS1645 . . . £35.70
- 4 45 DCOE/DHLA 26mm ram pipeKNSS2645 . . . £35.70
- 45 DCOE/DHLA 39mm ram pipeKNSS3945 . . . £35.70

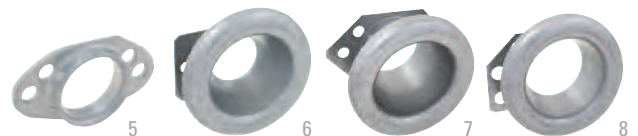

Ram pipes for SU carburettors

These fully radiused ram pipes improve air flow into the SU carburettor, ideal for use with or without filters (space permitting). The K&N ram stack is designed for their own filter assemblies.

- 5 HS4 K&N ram pipe - silver KN85-5039 . .£23.00
- HS2 ram pipe - silver SFR230£27.40
- 6 HS4 ram pipe - silver SFR430£27.40
- 7 HS6 ram pipe - silver SFR650£27.40
- 8 HIF44 ram pipe - silver SFR4430 . . . £29.30



MOTO-LITA STEERING WHEELS

Moto-Lita are among the finest replacement steering wheels available. Designed to enhance the appearance of the cockpit and provide an improved feel for the driver.

Available in a variety of styles, including polished or black painted spokes, with the option of polished wood or black leather rims.

Available in 13" to 15" diameters. Boss kits for each specified model of car are required for fitting (available separately).

Moto-Lita

See page A50 for more information



STAY INFORMED

Simply the quickest way to be kept up to date with news of our special offers and information on new and relevant products as they become available...

Visit moss-europe.co.uk and subscribe to our Newsletter e-mails.





FUEL INERTIA SWITCH KIT

This inertia switch is a good safety feature when using an electric fuel pump. The unit mounts to a vertical surface in the engine bay and in the unfortunate event of a crash cuts the power to the fuel pump preventing fuel spillage. Supplied with multi connector and tail leads to allow easy connections.

Fuel pump inertia switch kit C41220AX . . . £36.30

BATTERY CUT-OFF SWITCHES

Battery cut-off switches are a good idea for all cars. Fitting one enables you to quickly isolate the battery and immobilise the car; ideal when working on your car, or if you intend to put your car into storage. Use with a battery conditioner, see our website.



Battery mounted cut-off switches

These cut-off switches simply mount to the battery post and feature a screw-in knob to break the circuit. Available with a bypass fuse to allow sufficient current to pass to operate clocks, alarms and coded radios, but if any attempt is made to start the car the fuse will blow.

Battery mounted cut-off switch GAC3192X . . . £7.40
 Battery mounted cut-off switch with bypass fuse . GAC31921 . . . £13.46



In-line cut-off switches

These cut off switches need to be fitted into the main battery to starter cable. The body of the switch should be mounted securely to the car and cables fitted using the terminal kit.

Period cut-off switch

These are reproductions of the Lucas 'Battery Master Switch' which was a popular accessory on many British classics.

Period battery cut-off switch (short knob) 1B2804 £32.84
 Period battery cut-off switch (long knob) 1B2804L £32.84



Motorsport cut-off switches

Battery cut-off switches are obligatory for competition cars and should be fitted with a cable for remote access.

Battery cut-off switch TT7964 £17.90
 Battery cut-off switch race spec (FIA approved) . . TT7962 £30.70
 Remote cable 6 foot TT79621 £7.80
 Spare key for switches TT7964 and TT7962 TT79641 £5.24
 Terminal kit for battery cable TT7964TK . . . £10.20



TMG2930K

HIGH CAPACITY FUEL PUMPS

The standard fuel pump may not be able to maintain adequate fuel flow and pressure at higher engine speeds, particularly with a tuned engine. The Facet range of fuel pumps will suit all standard and modified engines fitted with carburettors. They give constant fuel flow and pressure, even at high temperatures eliminating the problems associated with vapour lock. The pumps are available in a variety of specifications to suit the engine's fuel pressure and flow requirements. Further fine tuning of the fuel pressure can be easily achieved by the use of a separate fuel regulator, see website. With safety in mind we recommend fitting a fuel pump inertia switch kit, so that in the event of an accident fuel delivery is automatically cut-off. Fuel lines may require adapting to install the new pump, check pipe sizes to select the correct unions, additional unions may be required.

Cylindrical fuel pumps

Formerly known as interrupter type pumps, these heavy duty pumps can be fitted at the front or rear of the car and up to 600mm above the bottom of the fuel tank. Kits are supplied with mounting & 8mm unions, alternative size unions available.

Cylindrical fuel pump kit - road Silver Top TMG2930K . . £114.40
 (Up to 150bhp, flow rate: 30 gal/hr, 4.0-5.50 psi, unions: 8mm x 1/8 npt)
 Cylindrical fuel pump kit - fast road Silver Top . . MGS2930K . . £119.60
 (Up to 200bhp, flow rate: 35 gal/hr, 6.0-7.0 psi, unions: 8mm x 1/8 npt)
 Cylindrical fuel pump kit - competition Red Top MGS2932K . . £117.70
 (Above 200bhp, flow rate: 40 gal/hr, 6.0-8.0 psi, unions: 8mm x 1/8 npt).
 Cylindrical fuel pump only - competition Red Top TT2930 £103.00
 (Above 200bhp, flow rate: 40 gal/hr, 6.0-8.0 psi, 1/4 npt threads).

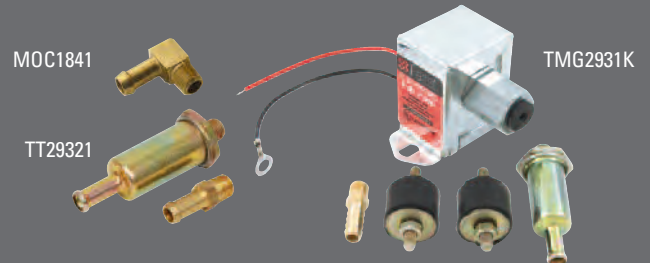

Solid state fuel pumps

These pumps should be mounted at the rear of the car (as they are designed to push fuel rather than draw fuel) and ideally below fuel tank level, although they will work up to 300mm above the bottom of the fuel tank. Kits are supplied with mounting & 8mm unions, alternative size unions available.

Solid state fuel pump kit - fast road TMG2931K . . £61.40
 (Up to 150bhp, flow rate; 32 gal/hr, 4.5-7 psi, unions: 8mm x 1/8 npt).
 Solid state fuel pump only - fast road MGS2931 . . . £43.70
 (Up to 180bhp, flow rate: 34 gal/hr, 7.0-10.0 psi, 1/8 npt threads).

Fuel pump unions

Use with the listed fuel pumps, please check thread and pipe size before ordering.

Straight union 1/4" (6mm) 1/8 npt FPA903B £1.92
 Straight union 5/16" (8mm) 1/8 npt MOC1604 £3.64
 Straight union 3/8" (10mm) 1/4 npt FPA904/B £3.07
 90° union 5/16" (8mm) 1/8 npt MOC1841 £6.14
 90° unions 5/16" (8mm) 1/4 npt (pair) TT2930A £13.20
 90° unions 3/8" (8mm) 1/4 npt (pair) FPA902B £12.20

Fuel filter union

Unions 1/4" (6mm) 1/8 npt (pair) TT29321 £8.64

ISOLATE THE BATTERY

UPDATED BRAKE PADS

EBC brake products are renowned for their high quality and excellent performance. All grades of brake pad use Kevlar as the binding material rather than the traditional steel, this prevents the build up of corrosive brake dust that can damage alloy wheels.

Tested in rally cars, these pads are high friction, fade resistant with immediate pedal response with a fantastic wear life. We stock their Ultimax and updated Greenstuff and Yellowstuff high performance brake pads.



EBC brake pads

EBC Greenstuff brake pads are a high efficiency upgrade pad which will increase your car's stopping power by 20% over standard replacement pads.

- Greenstuff pads 10" wheels (998cc Cooper) GBP102G **£32.00**
- Greenstuff pads 10" wheels (Cooper S, 1275cc) . . GBP103G **£38.30**
- Greenstuff pads 12" wheels (1275cc to 1974, 1984 on) . STR505G **£37.30**



EBC Yellowstuff brake pads are formulated for fast road use and track day use. The higher heat range means they will resist the effects of brake fade under heavy braking.

- Yellowstuff pads 10" wheels (998cc Cooper) GBP102Y **£57.00**
- Yellowstuff pads 10" wheels (Cooper S, 1275cc) . . GBP103Y **£59.00**
- Yellowstuff pads 12" wheels (1275cc to 1974, 1984 on) STR505Y **£80.70**



Mintex brake pads

Mintex M1144 is a hard wearing material ideal for fast road and track day use, giving good wear resistance and reduced fade under hard braking.

Mintex M1144 set (1275cc to 1974 & 1984 on) . STR5051 **£58.80**



UPDATED PADS FOR 4 POT BRAKES

Choose from the following options, heavy duty Kevlar for every day use Green for fast road use and Yellow for fast road and track days. This range of performance pads will fit all known 4 pot calipers (except the Wilwood kit).

- Kevlar pads for 4 pot - road GBP258KV . . . **£28.80**
- Greenstuff pads for 4 pot - fast road GBP258G . . . **£45.00**
- Yellowstuff pads for 4 pot - fast road/track day . . GBP258Y . . . **£71.60**



BRAKE MASTER CYLINDER

This large round reservoir brake master cylinder is suitable for Cooper S models or when upgrading your Mini to disc brakes.

Brake master cylinder .70 bore GMC172 **£80.40**

4 POT BRAKE PARTS

Brake discs are something that will eventually need to be replaced, easy enough if you have a standard brake setup but not so easy if you have four pot solid or vented discs fitted to you Mini!

These brake parts will fit KAD & Metro set ups. The high quality discs are suitable for all 8.4in vented applications. See Restoration section for our full range of brake components.

- Vented brake discs (each) MT1203 **£35.00**
- Stainless steel caliper piston 4 pot (each) MT5402 **£12.20**
- Seal kit for 4 pot calipers (1 caliper) GRK5003 **£10.30**
- Drive flanges (each) NAM6450F . . . **£42.00**
- Split pins for 4 pot calipers* (set of 4) TMG307521 . . . **£1.96**

(*Can also be used with Cooper models).

BRAIDED BRAKE & CLUTCH HOSES

The braking efficiency of your car can be increased by using high quality stainless steel braided brake hoses. Normal hoses expand slightly when brakes are applied. This expansion can now be reduced by using the stainless steel braided hoses, thus improving the feel of the pedal.

- Goodridge front braided hoses (pair) MT5102 **NCA**
- Goodridge front braided hoses (pair) Metro 4 pots . MT5103 **£51.80**
- Goodridge rear braided hoses (pair) MT5101 **£24.80**
- Goodridge rear braided hoses (pair) no metal pipe* . MT5104 **NCA**

(*This hose goes from the subframe bracket to direct to wheel cylinder replacing the metal pipe).

- Braided brake hose set (all models*) GAC8412X . . . **NCA**

(*This is a universal kit that fits both disc and drum brake cars. On some models a banjo fitting is used on one of the hoses and it will bottom out, cut 3mm off the banjo bolt thread).

- Braided diaphragm clutch hose GAC8446X . . . **NCA**
- Braided Verto clutch hose GAC8447X . . . **£14.50**
- Braided universal clutch hose* MT2401 **£24.80**

(*This universal clutch hose goes directly from the master cylinder to the slave cylinder, with banjo fittings at both ends).



NEGATIVE CAMBER LOWER ARMS

Adding negative camber improves the ability of the car to turn-in on a corner and as weight is transferred to the outside wheel, it will increase the contact area between the tyre and the road, giving you more grip.

These replacement lower arms offer varying degrees of negative camber over the standard item i.e. If a standard car leaves the factory with 1° positive camber, then fitting these arms will give 0.5° negative camber.

Because the front suspension consists of 2 unequal length arms, lowering the front ride height increases negative camber and conversely raising the front ride height will increase the positive camber.

Negative camber lower arms 1.5° (pair) WPT9001X . . . £60.00



ON CAR ADJUSTABLE LOWER ARMS

New design lower arms are now supplied with both rose joints and original bush type fittings. Adjustable on car lower arms make life much easier to set up for track days and if the car has been lowered and negative camber is required. (Supplied as a pair).

Adjustable lower arms (pair) C-AJJ3363 . . . £114.00

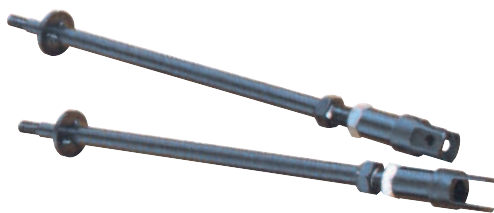

HEAVY DUTY TIE BARS

Tie bars perform the important function of controlling the front to rear movement of the front wheels under acceleration and braking. With recent improvements in the braking components that are now available for the Mini, it is possible for the standard tie bars to flex. This reduces the stability of the car and produces a feeling that the car is wandering. The increased diameter of these heavy duty tie bars reduces this problem.

These tie bars also enable you to adjust the castor angle of the front suspension. The castor angle determines the amount of self centring of the steering. The more castor angle, the more effort is required to turn the steering wheel. 3° of castor is specified by Rover as the optimum setting.

Heavy duty tie bars (pair) WPT9003X . . . £27.40



CAMBER GAUGE

Setting the camber of your car's suspension is essential to get the handling and steering correct. This gauge is an inexpensive way to check camber between positive 3° and negative 3° of camber. The magnetic base fixes to the brake disc or hub face.

Camber gauge MTR4201 . . . £37.10

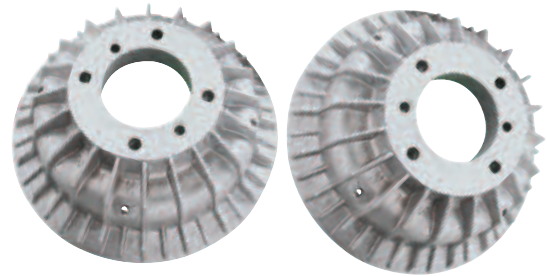

SUPERFIN ALLOY BRAKE DRUMS

A brand new superior lightweight alloy brake drum, pressure die cast with 25% more fins for extra cooling to improve braking efficiency and built-in spacer to give increased strength and reliability. Direct replacement for all post 1984 cars, Cooper S and 1275 GT's rear drums.

Superfin alloy brake drums (pair) MT1210 . . . £80.00



TT3949

REMOTE BRAKE SERVO KIT

For those who find the brake pedal rather hard after driving more modern vehicles, these remote servo kits make braking easier by reducing pedal effort. Suitable for all single line brake circuits they are remote mounted and easily plumbed into the hydraulic and vacuum systems of the car. We offer both a Lockheed and aftermarket kit, both are supplied with mounting brackets and hardware.

Remote brake servo kit Lockheed TT3949 . . . £198.00

Remote brake servo kit aftermarket TT3949Z . . . £95.50

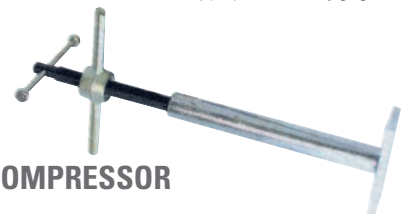

SUSPENSION CONE COMPRESSOR

These cone compressors are a must for changing rubber suspension cones or working on the front suspension of your Mini. Note: The new cones (Part No. FAM3968) have a metric thread.

Cone compressor metric cones only MT9600 . . . £29.10

Cone compressor metric & imperial cones GAC9424X . . . £79.90



COIL SPRING CONVERSION

FAM3968HX

Designed 45 years ago the rubber cones that Sir Alec Issigonis and Alex Moulton gave were innovative and perfectly adequate for the day, they are a bit harsh for today's driving. An alternative is to replace the rubber cones with springs that are a direct replacement. Offered in two different spring rates.

- Softer coil spring kit - blueFAM3968X . .£420.00
(Front and rear coil spring kit that replaces the rubber cone).
- Firmer coil spring kit - redFAM3968HX .£360.00
(Front and rear coil spring kit that replaces the rubber cone).



KGE100060SPK

SUPERPRO POLYURETHANE SUBFRAME BUSHES

For a fast road or road car the best compromise is to use polyurethane. Our Superpro poly bushes are the best compromise between subframe location and damping the road noise transmitted through the bodyshell.

- Front subframe tower pad kit subframe set KGE100060SPK £39.50
- Rear s/frame front mount kit split type axle set (to 1976) . . 2A5818SPK . . £16.94
- Rear s/frame front mount kit large axle set (1976 on) . . 21A2560SPK . . £17.75
- Rear s/frame rear mount kit split type axle set (all models) . 2A5818SPK . . £16.94

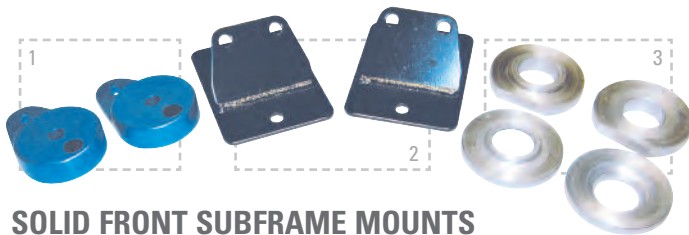

SOLID FRONT SUBFRAME MOUNTS

Maximum subframe location is gained by using solid mounts. Ideal for a race car but will transmit more noise and road harshness into the bodyshell.

- 1 Front subframe solid front mount* (each) . . .21A2624X . . .£28.70
- 2 Front subframe solid front mounts* (pair) . . .CSTR641 . . . £20.00
- 2 Front subframe solid rear mounts** (pair) . . .CSTR642 . . . £20.00
(*Fits to valance. **Fits to toe board).
- 3 Front subframe solid tower mount setCSTR640 . . . £19.20
(Includes: 2 x tower oval pads & 2 x tower round pads).



SOLID FRONT SUBFRAME MOUNTING KIT

Red anodised alloy front subframe washers replace the turret mount pads and teardrop mount to the front valance, to reduce the movement of the front subframe, so helping the handling.

- Alloy front subframe washer kit (8 piece)MT1205 £28.60



ALLOY TOWER BOLTS

- Anodised alloy tower bolt - silver (pair) 21A2596XSPR . £64.20
- Anodised alloy tower bolt - blue (pair) 21A2596XBPR . . NCA
(For more subframe mount components see the Restoration section).



GAC8437X

HI-LO SUSPENSION KIT

Change the ride height on your Mini. The original Hi-Lo kit allows you to raise or lower the height of your car without dismantling the suspension assembly. Homologated by the RAC and Rover for rallying.

- Hi-Lo suspension kit GAC8437X . .£128.11
- Adjustable cones kit (2 x cones, 2 x 21A423)GAC84371 . . . £55.00
- Extension rods (pair) GAC84372 . . . £15.00
(Use with GAC84371 when fitting to rear suspension rear allen bar).
- Front allen bar GAC84374 £7.00



GAC8432X

ADJUSTA-RIDE KIT

The most popular way to lower your Mini, while allowing easy and quick adjustment when needed. Using a simple threaded knuckle bar and lock nut system, you can easily raise or lower your Mini, without having to remove the top subframe mounts or drill the rear valance. The knuckle joints have also been re-designed for extra strength and durability.

- Front adjusta-ride kit GAC8432X . . .£61.80
- Rear adjusta-ride kit GAC8433X . .£111.70



BUDGET ADJUSTA-RIDE KIT

- A complete car set of adjusta-rides in polished alloy, including rear bars.
- Budget adjusta-ride kit MT1301 £101.14

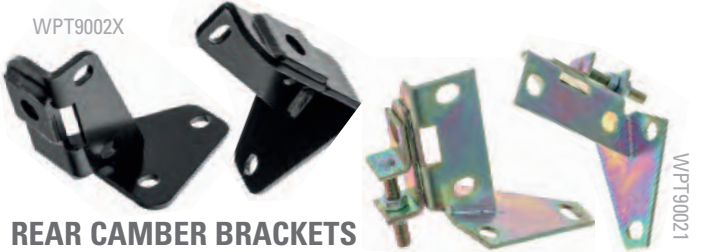

WPT9002X

WPT90021

REAR CAMBER BRACKETS

As with the front suspension, a small amount of negative camber on the rear suspension will improve handling. These brackets replace the standard outer radius arm bracket and will give 1.5° more negative camber. Unlike the front suspension, raising or lowering the rear ride height will not affect the camber angle. It is recommended that when more negative camber is used on the front, the rear should also be given more negative camber, to balance both handling and appearance.

- Rear camber brackets fixed 1.5° negative camber . WPT9002X . .£30.00
- Rear camber brackets adjustable WPT90021 . .£39.60



GAC84011XPR

GAC84041XPR

ADJUSTABLE SHOCK ABSORBERS

Shock absorbers are the first line in improving the handling of your Mini. We offer either Spax or Gaz front and rear adjustable shock absorbers for the Mini in either standard or lowered ride height option. Shock absorbers should be fitted as pairs to ensure the best performance and maximum safety of the car.

- Spax front standard height (pair) GAC84011XPR . . .£139.70
- Spax front lowered height (pair) GAC84021XPR . .£139.70
- Spax rear standard height (pair) GAC84031XPR . .£139.70
- Spax rear lowered height (pair) GAC84041XPR . .£139.70



GAC8401XG

GAC8402XG

GAC8403XG

- Gaz front standard height (each) GAC8401XG . . .£55.00
- Gaz front lowered height (each) GAC8402XG . . .£57.20
- Gaz rear standard height (each) GAC8403XG . . .£55.00
- Gaz rear lowered height (each) GAC8404XG . . .£57.20



SPCK19



SPK80ECF

SUPERPRO POLYURETHANE KITS

Polyurethane is preferable to rubber as it gives improved location without having a detrimental effect on noise levels or a harsh ride. Added advantages are improved longevity and unlike rubber it is not affected by ultra violet light, water, salt, oil or petrol. The Superpro bushes come with a steel sleeve and grease where necessary.

Advice: For the best subframe location for your road car use Superpro bushes on the front subframe tower mounts with new standard mounts on the valance and toe board. Use Superpro poly for all rear subframe mounts.

Car kits (1965-76)

- Complete car kit SPK80ECK . . .£75.25
(Inc: Front suspension, engine steady, rear subframe & steering column bushes).
- Complete front kit SPK80ECF . . .£46.80
(Inc: Front suspension & engine steady bushes).

SPK80LCK



Car kits (1976 on)

- Complete car kit SPK80LCK . . .£110.24
(Inc: Front suspension, engine steady, front subframe, rear subframe & steering column bushes).
- Complete front kit SPK80LCF . . .£80.40
(Inc: Front suspension, front subframe & engine steady bushes).
- Complete rear kit (Inc: Rear subframe bushes) . . SPK80LCR . . .£30.20

Suspension bushes

- Front lower arm bush kit (axle set) 21A1882SPK . £19.90
- Front tie bar bush kit (axle set) 31G1155SPK . £14.40
- Front upper arm & rear radius arm grease seal (each) . 115702SP £2.26

COIL OVER KITS

Developed between Spax and K.A.D. these coil over shock assemblies are simply the most versatile currently available for the Mini. Designed purely for road use they provide the ultimate in ride comfort and shock absorbance. The shock absorbers have fully adjustable gas cylinders with the added bonus of being able to adjust the responsiveness of the coil spring with the threaded collars.

Front and rear shocks are in the kit containing all new brackets and fittings to successfully mount the shocks. As can be expected from K.A.D. and Spax, full and precise fitting instructions are included within the kit.

- Standard height kit . . . SPCK19 . . . £641.70
- Lower height kit SPCK20 . . . £641.70



GAC8494X

ROOF GUTTER MOULDING

These roof gutter moulding strips are an ideal way to smarten and finish off the roof of your mini. Available in either chrome or black, the roof gutter moulding is supplied in a single length and simply clips onto the metal gutter edge.

- Roof gutter moulding, chrome GAC8494X . . . £14.00
- Roof gutter moulding, black GAC8494XB . . £14.00

BODY SEAM MOULDINGS

These highly polished stainless steel seam mouldings will not only brighten up the exterior of your Mini but being stainless steel they are rust free and are also cheaper than the genuine original replacement items. Use BMP128MS stainless steel clips, to replace the standard painted items. Suitable for all cars from 1959 to current date.

- Front seam mouldings (pair) . . 8B12400 £31.00
- Rear seam mouldings (pair) . . 8B12401 £29.20
- Seam mouldings clip BMP128MS . . . £0.32



8B12401

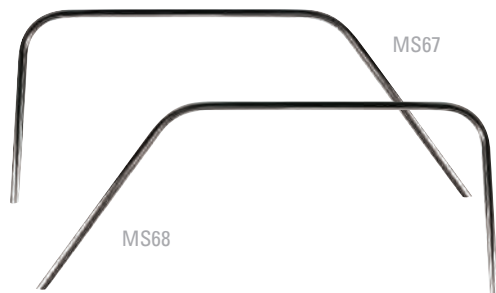

MS67

MS68

UPPER DOOR MOULDINGS

Another styling accessory for those craving the retro look, these stainless steel mouldings are based on those fitted to the MkI and MkII Mini Coopers. Now available for cars with wind-up windows (ie: 1969 to current). If you think there is never too much bright work, then these are for you.

- Top door trim lefthand (MkIII) MS67 £37.00
- Top door trim righthand (MkIII) MS68 £37.00
- Top door mouldings clip 13H743 £1.30

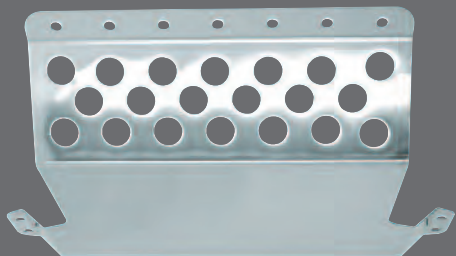

SUMP GUARD

Protect the gearbox - one of the most important components on your Mini. Lowering the car and speed bumps are not a great combination and the gearbox casing is quite expensive to replace. A lightweight stainless steel sump guard is the perfect way to protect the gearbox.

- Stainless steel sump guard MT1207 £70.00



SMARTSCREEN WASH/WIPER SYSTEMS

These SmartScreen wiper kits allow intermittent wiper delay of between three and thirty seconds, programmed by using your existing wiper switch. SmartScreen wash/wiper kit allows you to have an automatic wiper system when using your electric screen-wash. All kits are easy to fit and come with full instructions.

SmartScreen wiper system

- Positive earth (to 1969) GAC9222X . . . £31.20
- Negative earth (pre 1969 converted) GAC9224X . . . £31.20
- Negative earth (1969 on) GAC9221X . . . £31.20

SmartScreen wash/wiper systems

- Negative earth models (1969 on) GAC9225X . . . £52.50



MS85H

HEATED WINDSCREENS

These high quality heated windscreens are the easy way to demist your windscreen - perfect for motorsport applications and those damp mornings.

“Demist your windscreen in around 20 seconds”

Manufactured to the latest British Standard these laminated windscreens feature a virtually invisible micro-wire element within the screen to effectively demist without impairing vision, it's the type of element used in many modern luxury cars. Installation is simple using standard rubbers and filler strip. We also offer wiring kits with relays to enable easy connection.



24A2236HM

Available in two styles; Monte Carlo, a reproduction of the original style as used in the Mini's rallying heyday. This screen uses a dual zone circuit and requires fitting kit GAC40251. Standard style screens do not have the thick horizontal bars and are available in a range of tint options as listed below, these screens use a single zone circuit and require kit GAC4025.

- Heated windscreen - green tint/green top tint . . MS85H £213.00
- Heated windscreen - green tint CZH4048H . . . £211.80
- Heated windscreen - clear 24A2236H . . . £193.40
- Heated windscreen, Monte Carlo style - clear . . 24A2236HM . . £269.60

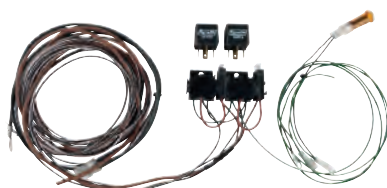

GAC40251

Wiring kits

- Wiring kit - single zone GAC4025 . . . £32.60
- Wiring kit - dual zone GAC40251 . . . £50.30



Kit inc:
WPA9021X, WPA9032S
WPA9028X, WPA9022X

COMPLETE WIPER, JET & BEZEL KIT

This kit contains a full set of windscreen wiper arms & blades, wiper bezels, chrome washer jets and screw fitting wiper hole bungs.

Complete wiper jet & bezel kit WPA9067X . . . £52.80

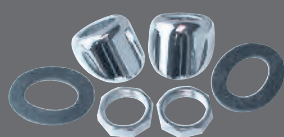

CHROME WIPER WHEELBOX BEZEL KIT

This is a very simple kit to fit but it goes a long way to improving the appearance of the front end, especially if you've just resprayed your Mini.

Chrome wiper wheelbox bezel kit WPA9028X . . . £9.00



WIPER HOLE PLUGS

Spruce up the scuttle panel with these stainless steel rubber backed plugs.

Wiper hole plugs (each) WPA9032X . . . £5.70
Wiper hole plugs screw fitting (pair) WPA9032S . . . £8.90

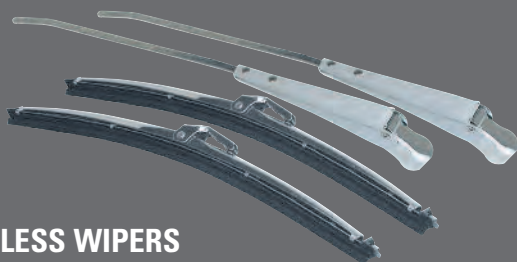

STAINLESS WIPERS

This kit is a direct replacement for the rather boring black wiper arms that are supplied on recent Minis. Available for either LHD or RHD cars.

Wiper arm kit RHD WPA9022X . . . £24.71
Wiper arm kit LHD WPA9023X . . . £24.71



CHROME WASHER JET KIT

The original washer jets are not all that helpful at cleaning the Mini's screen, so upgrading to twin nozzle chrome washer jets will improve things greatly.

Chrome washer jet kit WPA9021X . . . £9.32

BUMPER & OVERRIDER KIT

If you want to give your car the retro look, overrides and corner bars are a must. We supply 2 kits, a complete bumper and override kit and an override kit.

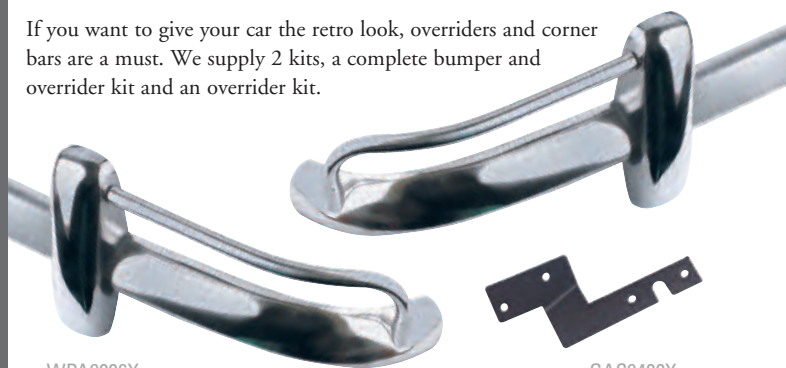

WPA9006X

GAC9400X

The complete kit contains: 2 bumper blades - pre drilled for corner bars, 4 overrides, 4 corner bars and all hardware giving the MkI look. The override kit contains: 4 overrides and hardware to give the MkII look. For cars made from 1980 on, rear fog lamps were fitted as standard so you'll need a relocation bracket, (RHD only).

Bumper & override kit (MkI) WPA9006X . . £310.00
Override kit (MkII) WPA9005X . . £86.40



WPA9005X

Override components are also available separately:

- Override chrome RHF & LHR* (MkI) 14A9923 . . . £20.00
- Override chrome LHF & RHR* (MkI) 14A9924 . . . £20.00
- (*With holes for corner bars).
- Overrides stainless steel** (MkII) 14A8738SS . . £20.00
- (**Without holes for corner bars).
- Corner bar RHF 14A9877 . . . £15.00
- Corner bar LHF 14A9878 . . . £15.00
- Corner bar RHR 14A9919 . . . £14.00
- Corner bar LHR 14A9920 . . . £15.30
- Override fitting bracket 14A7598 . . . £1.25
- Override fitting bolt SH605101 . . . £0.84
- Bumper to corner bar distance piece 14A9879 . . . £1.50
- Rear fog lamp relocation bracket RHD GAC9400X . . £28.30



GAC9212X

GAC9213X

SCREEN WASHER KITS

The electric washer kit converts your existing manual pump washer system. Both kits are supplied complete with fittings, pump and plastic washer bottle.

Screen washer conversion kit manual GAC9212X . . £55.20
Screen washer conversion kit electric GAC9213X . . £30.20



CZH1784S

CHROME EXTERIOR HANDLES

Enhance the appearance of your Mini with chrome plated exterior handles. The sets comprise of two push button handles and a boot handle with matched keys and locks. Choose either a MkI or MkIII boot handle.

- Chrome handle set with MkI boot handle CZH1784S . . . £98.90
- Chrome handle set with MkIII boot handle WPA9019X . . .£144.00

DOOR HANDLE ESCUTCHEONS



An ideal way to protect your paintwork and smarten the appearance of the Mini.

- Plain door handle escutcheons (pair) WPA9011X . . .£7.15

LOCK & BARREL SETS



Lock and barrel key sets to fit your MKI-II Mini.

- Lock and barrel key set, 2 locks (doors) LBS108£42.22
- Lock and barrel key set, 3 locks (door, ignition & boot) LBS103£31.39
- Lock and barrel key set, 4 locks (2 doors, ignition & boot) LBS104£38.45

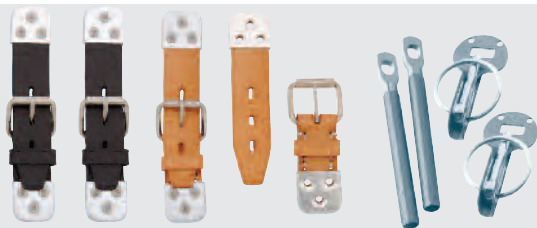

BONNET STRAPS & PIN SET

Works style bonnet straps add a classic race & rally look to any classic car. Originally used by the factory BMC Special Tuning department to prevent unwanted opening of the bonnet these straps are perfect for those recreating that retro rally car look or just wanting peace of mind. Manufactured from high quality leather with stainless steel end plates. Available in tan or black either individually or in pairs. Or choose a set of stainless steel bonnet pins to give a modern competition look. Some bodywork modification is required to enable their use.

- Bonnet strap black (single) 222-601£18.25
- Bonnet strap set black (pair) 222-602£33.85
- Bonnet strap tan (single) 222-729£18.25
- Bonnet strap set tan (pair) 222-728£33.85
- Stainless steel pin set MRAC801S . . .£17.60

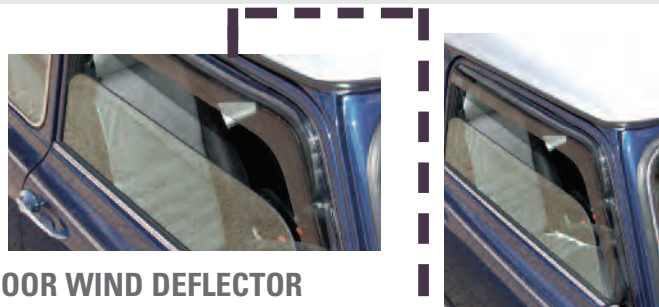

DOOR WIND DEFLECTOR

These wind deflectors fit neatly into the door window channel and allow you to drive with the window open slightly for extra ventilation without being buffeted.

- Door wind deflector (pair) MT9316£65.00



QUICK RELEASE BONNET HINGES

Designed for the MkIII, the hinges enable you to easily remove the bonnet for engine work, while not increasing the risk of the bonnet going into orbit.

- Quick release bonnet hinges (MkIII) MSSK019 . . . £34.00



CHROME HORN

Keeping the under bonnet area looking its best is always easier when you have a few chrome parts fitted. Direct replacement horn finished in luscious chrome.

- Chrome classic horn 105mm MT9143£16.70



AIR HORN KIT

Let them know your coming.
Note: May not be legal for road use, please check local regulations.

- Dual air horn kit GAC9978X . . .£40.30



MKI NUMBER PLATE KIT

Put one of these on your Mini and fool people into thinking that it's a MkI. Our hinged plate kit includes all fittings (except light unit). Choose from either a black or chrome finish lamp unit.

- Number plate kit GAC8438X . . .£34.90
- Number plate lamp unit - chrome 127916£24.40
- Number plate lamp unit - black 127916BLK . . .£30.30



NUMBER PLATE SURROUND

Manufactured from durable injection moulded ABS plastic, this chrome finish surround can be fitted in minutes to the front or rear of the vehicle.

- Chrome number plate surround GAC0070 . . . £12.50



MKIII NUMBER PLATE LAMP HOUSING

- Chrome metal number plate lamp housing (MkIII) . GAC4614 . . . £16.80



BRITISH LEYLAND STYLE DOOR MIRRORS

Rectangular polished stainless steel door mirrors suitable for all Minis with a choice of either flat or convex glass. Supplied with angled base and fittings. Use adaptor plates to fit to doors with late type captive nuts.

- Door mirror convex glass RH GAM215A £34.00
- Door mirror convex glass LH GAM216A £34.00
- Door mirror flat glass RH GAM217X £31.00
- Door mirror flat glass LH GAM218X £31.00
- Adaptor plate kit RH CZH1626 £7.80
- Adaptor plate kit LH CZH1625 £7.80



ROVER STYLE DOOR MIRRORS

These late type plastic door mirrors are available in black plastic or primed. Later models have the plastic door mirror painted in either white or body colour. Pre-painted mirrors are no longer available. Primed mirrors should be purchased and painted to suit your car.

- Plastic door mirror RH - black JPC9848 £22.00
- Plastic door mirror LH - black JPC9849 £22.00
- Plastic door mirror RH - primed CRB10184LML . £57.20
- Plastic door mirror LH - primed CRB10185LML . £67.60



Chrome Cooper door mirrors

Replacement chrome door mirror that fit the original captive nut mountings on the car so no need to drill extra holes.

- Chrome Cooper door mirrors (pair) MT9142 £52.80



ALUMINIUM RACING MIRRORS

These racing mirrors echo a bygone era of motorsport. Available in polished or satin finish with a black base, both feature a flat glass and single bolt fitting.

- Polished alloy mirror (each) MT9314 £27.00
- Satin finish alloy mirror (each) 222-355 £27.00

BULLET STYLE MIRRORS



Long base mirrors

These feature a 3.75" long base and are fixed with two screws from inside the door at 2" centres. Suitable for left or righthand mounting.

- Chrome flat glass GAM105 £13.50
- Chrome convex glass GAM105C £18.30

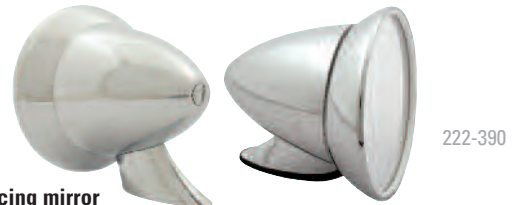

Long base racing mirror

This mirror features a larger 4.25" lens with a 3" base. It is externally fitted to the mounting bracket. Suitable for left hand or right hand mounting.

- Chrome flat glass 222-390 £34.10



British Leyland style mirrors

These feature a 3.75" long base and are plinth mounted as per British Leyland style door mirror. They are interchangeable with British Leyland type door mirror. Use adaptor plates to fit to doors with late type captive nuts.

- Chrome flat glass RH GAM106 £58.00
- Chrome flat glass LH GAM107 £58.00
- Adaptor plate kit RH CZH1626 £7.80
- Adaptor plate kit LH CZH1625 £7.80



Dual base mirror

Dual base mirror is supplied with two bases; the short base is 2.25" long and the large is 4.5" long, the mirror can be fixed to the car using either base to cover previous mirror fixing holes. Suitable for left or righthand mounting.

- Dual base chrome flat glass 222-372 £36.70

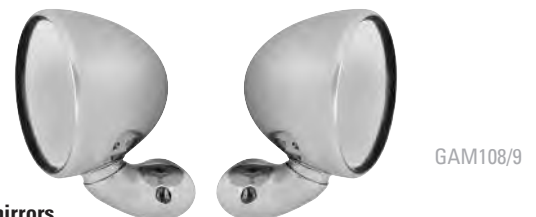

Racing door mirrors

These great looking chrome bullet door mirrors are a must! They look great on the Mini and include adaptor plates to easily fit door skins with captive nuts.

- Bullet racing door mirror RH (MkIII on) GAM108 £29.00
- Bullet racing door mirror LH (MkIII on) GAM109 £29.00
- Bullet racing door mirror (pair) (MkIII on) GAM108/9 £54.00



FUEL CAPS

Aston locking fuel caps

These quality locking fuel caps are a direct replacement for the original cap. Most carburettor models will require a vented cap (green) whereas fuel injection models (SPI & MPI) require a non-vented cap (red).

- Aston locking fuel cap, vented (90mm) GAC41271 . . . £38.24
- Aston locking fuel cap, non vented (90mm)GAC41272 . . . £35.17



Locking fuel caps

Use with our Aston fuel cap covers or on their own; most carburettors will require a vented cap whereas fuel injection models (SPI & MPI) will require a non-vented cap.

- Standard locking filler cap vented (green) GSS154£14.40
- Standard locking filler cap non-vented (red) WLD100310 . .£14.40



ALUMINIUM BODY PANELS

If you have to change your door skin's or the boot lid skin because they are corroded, why not to replace them with the aluminium version. You will never have to replace them again, and as it's aluminium, it's lighter than the original steel panel.

- Boot lid, skin, aluminium HMP441051 .£120.00
- Door skin, RH, aluminium, MKI-IIHMP441052 .£125.00
- Door skin, LH, aluminium, MKI-II HMP441053 .£125.00
- Door skin, RH, aluminium, 1970 - Onwards . . . CZH3300AL .£57.30
- Door skin, LH, aluminium, 1970 - Onwards . . . CZH3301AL .£57.30



Aston fuel cap covers

These fuel cap covers are designed to fit to our filler cap GSS154 for vented or WLD100310 for non-vented, and fixed by grub screws to the cap. The flap is lifted to reveal the lock and the cap & cover are removed together. The covers and caps are sold separately.

- Aston cap cover only, large (90mm) - chrome . . . GAC4127X . . .£27.95
- Aston cap cover only, small (75mm) - alloyMCC299£44.40



DUMMY FILLER NECK

Can't quite stretch to the price of the right hand petrol tank but would like people to think you can? Then we have just the thing for you. A filler neck which just screws onto the panel. The kit includes a template for correct positioning on the bodywork.

- Dummy filler neckGAC8436X . . .£18.00



DYNOLITE OILS

Dynolite offers a premium quality range of lubricants and consumables developed for Veteran, Vintage & Classic cars and motorcycles.

Dynolite lubricants are formulated to exceed the original vehicle manufacturer's specifications and are blended using high quality base oils combined with additive formulations that are suitable for use in these historic vehicles.

For example, Dynolite Pre-War and Dynolite Classic engine oils include optimal levels of ZDDP to reduce wear, which is often found at reduced levels in modern engine oils.



Visit moss-europe.co.uk for more information



WPA9038X

500929ALLOY

HEADLAMP RIMS

As fitted to the original Radford de Ville and other luxury Minis of the 1960's, these high quality chrome headlamp rims have a different profile to standard giving the impression of being wider.

For Mini owners who think their car is getting a little bit overweight, aluminium headlamp rims are available with an anodised finish, to replace the standard steel on brass rim, not suitable for Clubman models.

- Chrome headlamp rim (pair) WPA9038X . . . £54.00
- Alloy headlamp rims (each) 500929ALLOY . £25.30

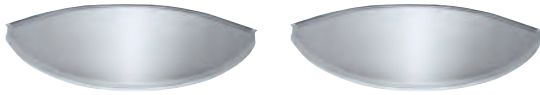

HEADLAMP PEAKS

As fitted to the original Radford de Ville and other luxury Minis of the 1960's, these high quality peaks change the profile of your Mini headlamps.

- Headlamp peaks (pair) GAC7999X . . . £11.65

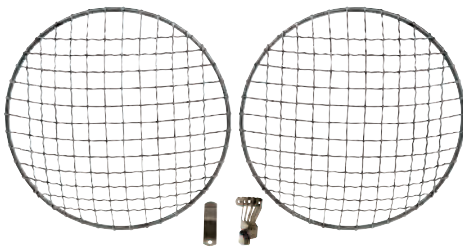

CHROME HEADLAMP STONE GUARDS

Add some protection to your headlamps with these period styled chrome headlamp guards. A good excuse to fit more chrome.

- Chrome headlamp stone guards (pair) GAC8000X . . . £12.14



RTC430A

GAE132G

3H3058

GWW102X

GENERAL SWITCHES

A range of period looking switches for general purpose use. Use a momentary switch for starters, horns, washers, and the 1 position for auxiliary lamps.

- Push button switch, momentary 3H3058 £13.80
- Toggle switch, momentary GWW102X . . . £17.40
- Toggle switch, on/off RTC430A £4.50
- Pull switch, on/off - white illumination GAE132 £18.00
- Pull switch, on/off - green illumination GAE132G . . . £18.00
- Pull switch, on/off - red illumination GAE132R . . . £18.00
- Pull switch, on/off - yellow illumination GAE132Y . . . £18.00
- Fuse holder, inline UKC4446 £1.96



WPA9026X

INDICATOR CLEAR LENS KITS

Early style lens kits

This early style clear lens kit is available with either beehive or flat glass lenses which are held in by a chrome rim, perfect for the retro look. Each kit contains two glass lenses, two retainer rims and two orange bulbs.

- Early beehive clear lens kit WPA9026X . . . £17.40
- Early flat clear lens kit WPA9030X . . . £38.40
- Replacement bulb GLB343 £1.96



CDU3374CR

WPA9027X

Later style lens kit

For 1984 on models, this kit contains 2 clear lenses, amber bulbs and screws.

- Clear (screw ret.) indicator lens kit (1984 on) . . . WPA9027X . . . £8.40
- Replacement single filament bulb - amber GLB343 £1.96
- Lens finisher bezel chrome (each) CDU3374CR . . £9.00



AHU2592CR

WPA9043X

CLEAR WING REPEATER KIT

Also available is a clear wing repeater kit for later cars (1984 on) including a pair of lenses and amber bulbs.



MT3703

- Clear wing repeater kit (1986 on) WPA9043X . . . £10.00
- Wing repeater replacement bulb - amber GLB501X £1.36
- Wing repeater wiring MT3703 £20.90
- Side repeater bezel chrome (each) AHU2592CR . . £9.30



GAC4616



BCA4294



RTC430A



GAC4612



GAC9400X

LAMP BRACKETS & SWITCH

The right parts to fit your lovely new spot and fog lamps with.

- Spot lamp bracket OE Rover type XBU10044 . . . £16.20
- Stainless steel spot lamp bracket (pair) GAC4612 . . . £14.30
- Stainless steel original works style lamp bar kit . . GAC4616 . . . £69.20
- Fog lamp relocation bracket (fitting overrider kit) . GAC9400X . . £28.30

A period style toggle switch for your lovely new lamps. It can also be used for other electrical accessories.

- Toggle switch off/on RTC430A £4.50
- Toggle switch off/on/on BCA4294 . . . £11.70

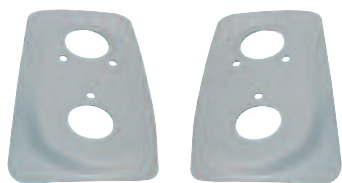

MKI REAR LAMP CONVERSION

The MkI rear lamp is probably the largest part of a true retro look. The conversion has been made easier with the arrival of the adaptor plates that can be welded into the original MkII or MkIII light unit apertures.

Adaptor plates (pair)GAC8452X ... **£26.95**



BHA4229

BHA4228

MkI lamp unit RHBHA4228 **£53.90**
 MkI lamp unit LHBHA4229 **£53.90**



GAC4617

CLEAR REAR LENS CONVERSION

This very popular conversion can be combined with our other clear lens kits (clear front indicators and side repeaters) completing the total clear lens look, or fitted on its own, giving the Mini a contemporary appearance. Lenses are sold as a pair of stop/tail & indicator lenses without bulbs. Suitable for all Minis from 1976-99 with 2 piece lenses on Lucas type bases. Reverse lamp lenses are also available separately.

Clear rear lens set (pair) GAC4617 **£16.30**
 Bulb twin filament red stop/tail (2 required) ... GLB380R **£2.23**
 Bulb single filament amber indicator (2 required) .GLB343 **£1.96**



XFJ10029

XFJ10028

Lens reverse lamp RH XFJ10028 **£14.40**
 Lens reverse lamp LHXFJ10029 **£18.00**



JEWEL REAR LAMPS

Something a little different! Jewel rear lamps certainly stand out from the rest. Supplied as a complete set with bulbs.

Rear jewel lamp setMT3700 **£62.75**



GAC4611

WPS6007

Chrome 5.5" standard pattern spot lamps (pair) . GAC4610 **£44.50**
 Chrome 5.5" standard pattern fog lamps (pair) .. GAC4611 **£51.80**
 Replacement bulb H3 GLB453 **£3.98**
 Wiring fitting kit (universal) GAC4027 **£12.00**

Wipac 5.5" chrome plated driving & fog lamps, with tough plastic lens covers.

Driving lamp (pair) - WipacWPS6007 **£30.60**
 Fog lamp (pair) - WipacWPS6078 **£30.60**

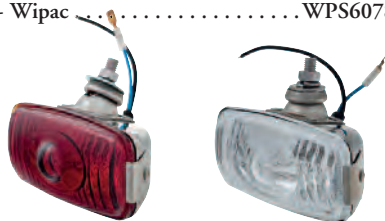

GAC4608

GAC4609

AUXILIARY REVERSE & FOG LAMPS

Many classics were not originally fitted with reverse or rear fog lamps. These universal polished stainless steel lamps measure 55mm x 110mm (2" x 4.5" approx.) and can be easily fitted, ideal for mounting under bumpers etc... Fog lamps require an illuminated switch mounted visibly on the dashboard.

Auxiliary fog lamp GAC4608 **£18.60**
 Auxiliary reverse lamp GAC4609 **£19.60**
 Bulb replacement 12V 20WGAC4608B **£3.32**



HEADLAMP PROTECTORS

A thin, invisible layer of Lamin-X protects headlamps from stone chips and scratches, and keeps your lights looking new for years to come. Fits all 7" round headlamps. Sold as a pair. Lamp unit not included.

Headlamp protectors (pair) 162-695 **£17.80**





WIPAC

GAC4023Z

H4 HALOGEN HEADLAMP CONVERSIONS

Fitting a halogen headlamp conversion is one of the easiest and most worthwhile improvements you can make to your Mini. Powerful halogen bulbs with an improved lens design result in a superior light beam without blinding oncoming traffic. No matter how fast your car is you can only travel as quickly as your vision allows. For the ultimate night vision use one of these H4 conversion kits with our HID conversion kit (GAC4022H).

Lucas H4 headlamp conversion kit RHD (pair) . . .GAC4023 . . . **£50.00**
 Wipac H4 headlamp conversion kit RHD (pair) . GAC4023Z . . .**£51.25**
 Wipac H4 headlamp conversion kit LHD (pair) . WPS4699 . . . **£61.60**



GAC4600

GAC4022X

HALOGEN HEADLAMP REPLACEMENT BULBS

Standard halogen H4 60/55 watts (each) GLB472 **£5.12**
 Halogen H4 100/90 watts (each) (check regulations) . GLB484 **£6.20**
 Xenon H4 60/55 watts (pair) GLB472X **£10.40**
 Xenon H4 60/55 watts - blue tint (pair) GLB472BLU . . **£10.40**
 (Xenon bulbs are up to 30% brighter than the standard halogen bulb).

CRYSTAL HALOGEN HEADLAMP KITS

These crystal lamps give your car a modern look with the beam pattern moulded into the reflector rather than the lens. Manufactured with a tough polycarbonate clear lens they are available with or without pilot lamp, and are a direct replacement for original 7" sealed beam or H4 conversion lamp units. Headlamp bulbs are supplied separately.

Crystal halogen without side light kit** (pair) GAC4022X . . **£58.90**
 Crystal halogen with side light kit** (pair) GAC4023X . . **£50.00**
 (**'E' marked for legal road use, use dipping H4 bulbs. RHD only).
 Crystal halogen with angel eye kit* (pair) GAC4600 . . . **£56.80**
 Crystal halogen kit* (pair) GAC4615 **£38.80**
 (*'NOT 'E' marked for legal road use, no dip pattern).

BASE OR BACK MOUNTING



BHA4399

MM162-800

MM162-700

PERIOD STYLE LAMPS

These outstanding reproductions of the original Lucas L576 units are available as either a driving lamp with a clear lens or a fog lamp with a fluted lens in either a base or back mounting. Use a back mounted fluted lamp as a works style reverse lamp.

Driving lamp with clear lens (each) MM162-700 . . **£84.00**
 Front fog lamp with fluted lens (each) MM162-800 . . **£84.00**
 Back mounted lamp with fluted lens (each) BHA4399 . . . **£84.00**
 Back mounted lamp with clear lens (each) 57H5322 **£84.00**

We stock replacement units, so you don't have to buy the whole lamp again.

Replacement lamp unit with fluted lens (each) . . ACG5179 . . . **£37.00**
 Replacement lamp unit with clear lens (each) . . 57H5015 . . . **£38.15**
 Replacement bulb driving lamp (each) GLB185 **£4.92**
 Replacement bulb fog lamp (each) GLB323 **£4.80**

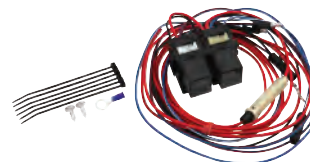

117-515

HEADLAMP RELAY KITS

Fitting halogen headlamps puts high loads on electrical components. These kits allow easy installation of relays into the headlamp circuit allowing for the high current circuit to be run through the relay. Fitting relays in headlamp circuits protects your wiring and reduces the resistance in the circuit allowing full power to the lamps. Kits include relays and fittings. The single relay kit can also be used for wiring spotlamps, horns and other electrical accessories.

Headlamp relay kit 2 relay 117-515 **£35.70**
 (Inc: 2 relays, pre-wired relay holders, fitted terminals, fittings & instructions).
 Relay kit 1 relay GAC4027 **£12.00**
 (Inc: 1 relay, non-assembled wiring, terminals & fittings).
 PVC tubing black pre cut metre 504806 **£0.90**



MRAC402

WORKS STYLE WHEEL ARCH SETS

These 'Works' style wheel arches are replicas of the works style of arch fitted to race and rally Minis in the sixties and give your car that great retro look. Group 2 arches are also available for 6" wheels with an extra lip on the outer edge of these arches means a chrome finisher can be fitted GZF105 for deluxe or GZF107 for flat. Group 5 arches are suitable for cars with up to 7" wheels. Made from fibreglass with a black gel coat finish and require drilling to fit.

- Group 2 arch set no lip - 1.75" wide/5" wheel . . MRAC401 . . .£77.50
- Group 2 arch set with lip - 3.5" wide/6" wheel . . MRAC402 . . .£62.00
- Group 5 arch set no lip - 3.5" wide/7" wheel . . . MRAC405 . . £115.00
- Chrome finisher deluxe GZF105£9.60
- Chrome finisher flat GZF107£6.00



GAC8449X

STAINLESS STEEL WHEEL ARCH COVER KIT

To brighten up the exterior of the Mini why not add these quality stainless steel arch extension covers which screw onto the standard arch extensions.

- Stainless steel wheel arch cover kit GAC8449X . . £105.00
- Stainless steel moulding (pair) GAC84491X . . £93.00



WPA9101

SPORTS PACK WHEEL ARCH KIT

As fitted to Rover sports pack Minis, this very popular wheel arch kit is made from fibreglass and includes fixing studs & rubber edge trim. Sill trim not included. These arches protrude 3.5in. Some modification to the front metal arches may be necessary if fitting 13in wheels to non sports pack Minis.

- Sports pack wheel arch kit fibreglass WPA9101 . . .£144.00
 - Sill finisher DDJ10002 . . . £21.80
- (Rubber strip fitting along sill between front and rear arch extensions).



AJM1117Z

PLASTIC WHEEL ARCH KITS

These plastic wheel arch extension kits were standard on many Minis, however if they are too subtle for you, we also stock various wider options.

- Wheel arch kit - black AJM1117Z . . . £29.00

Kit AJM1117Z includes (also available separately)

- Wheel arch extension front righthand - black . . . CZH4312Z . . .£7.20
- Wheel arch extension front lefthand - black . . . CZH4313Z . . .£7.20
- Wheel arch extension rear righthand - black . . . CZH4314Z . . .£7.20
- Wheel arch extension rear lefthand - black . . . CZH4315Z . . .£7.20
- Sill finisher CZH4316Z . . .£4.70
- Rivet for wheel arch (quantity as required)DYQ100140 . . . £2.00



CAT10044

AJM164

REAR MUD FLAPS

These are genuine Rover mud flaps as fitted to later Minis.

- Rear 'Mini' mud flap set AJM164 £41.40
- Rover 'Mini Cooper' rear mud flap set CAT10044 . . . £43.30



TT6902

WHEEL SPACERS

These spacers will allow small adjustments to be made to the offset (to ensure wheel and tyre clearance) when fitting alloy wheels. Can also be used to space your wheels out to fill the wheel arches. When choosing the width of the spacer ensure that it will leave adequate thread length for secure wheel fitment.

- 3mm wheel spacer (pair) TT6901£18.10
- 6mm wheel spacer (pair) TT6902£19.70



MT7122

- 9mm (3/8in) solid wheel spacer with stud kit . . . MT7120 £28.00
- 19mm (3/4in) solid wheel spacer kit with stud kit .MT7121 £31.00
- 25mm (1in) solid wheel spacer kit with stud kit . MT7122 £34.80



GAC8210X



GAC8313X

8 SPOKE ALLOY WHEELS

A carefully selected set of alloy wheels will not only enhance the appearance of your Mini, but could also help improve the handling by allowing the fitment of wider section tyres. Wheels are supplied without wheel nuts.

- 8 spoke alloy wheel 10" x 5" (each) - silver GAC8210X . . . £70.00
- 8 spoke alloy wheel 10" x 6" (each) - silver GAC8208X . . . £70.00
- 8 spoke alloy wheel 13" x 6" (each) - silver GAC8313X . . £104.00

- Wheel nut for 10" 8 spoke wheel (each) GAC8210XNT . £1.36
- Wheel nut for 12" & 13" 8 spoke wheel (each) AHA8785 £1.56



88G337Z

GAC8215X

10" COOPER STYLE ALLOY WHEEL

These great looking 4.5J wheels recreate the classic look of the early Cooper steel rims, they look smart on any Mini going for the classic look. Our chrome hub caps are the perfect complement to these wheels.

- Cooper style alloy wheel 10" (each) GAC8215X . . . £76.80
- Chrome wheel nut for 10" Cooper style wheel (each) . GAC8210XNT . . £1.36
(Chrome plated nut. Use without hub cap).
- Chrome hub cap (each) 88G337Z £32.00
- Plain wheel nut for 10" Cooper style wheel (each) . 88G322 £0.79
(Plain steel nut. Use with hub cap).



WPA9104X

8 SPOKE ALLOY WHEEL WITH POLISHED RIM

This 12" eight spoke alloy wheel has a polished rim, and an offset designed to complement the wheel arch set WPA9001X, see opposite. Supplied with centre caps only.

- 8 spoke 12" x 5" (each) - silver WPA9104X . . . £94.00
- Chrome dome nut (each) WPA91042X . . . £4.20



MT7104



MT7108

REVOLUTION ALLOY WHEELS

The Revolution 4 spoke and the 5 spoke RFX wheels are supplied without wheel nuts. The black alloy wheels feature black spokes with a silver rim.

- Revolution 4 spoke 6" x 10" (each) - black MT7101 £69.70
- Revolution 4 spoke 5" x 12" (each) - black MT7104 £82.80
- Revolution 4 spoke 6" x 12" (each) - chrome MT7112 £35.00
- Revolution 4 spoke 7" x 13" (each) - black MT7114 £35.00

- Wheel nut for 4 spoke 10" & 12" wheel (each) MT7100X £2.57
- Wheel nut for 4 spoke 13" wheel (each) MT7100 £2.23

Revolution 5 spoke RFX alloys

- Revolution 5 spoke RFX 5" x 12" (each) - silver MT7108 £76.00
- Wheel nut for 5 spoke RFX wheel (each) GAC8210XNT . £1.36

Please note: All wheels are sold individually unless otherwise stated, ensure you use the correct wheel nuts for each wheel.



CHROME HUB CAP

This chrome reproduction hub cap fits any 10" wheel for a stock, very original look to your Mini.

- Chrome hub cap for 10" wheels (each) 88G337Z £32.00



162-705

162-706

SPOT/FOG LAMP COVER WITH LUCAS LOGO

This authentic period style, vinyl spot/fog lamp cover features the Lucas lion logo. Suitable for 6" and 7" diameter lamps with a small clear window to see if the lamps are on or off.

- Lucas spot/fog lamp cover, 6", black (each) 162-705 £56.10
- Lucas spot/fog lamp cover, 7", black (each) 162-706 £56.10



1

2

3

4



5

CLASSIC DECALS

A small selection from our range of decals available for your car, please refer to the Restoration section for a listing of the exact requirements for your model.

- 1 BMC rosette (external) CRTR208 £5.50
- BMC rosette (internal) CRTR204 £5.50
- 2 BMC Special Tuning rosette (external) CRTR207 £5.50
- BMC Special Tuning rosette (internal) CRTR207A £5.50
- 3 Leyland Special Tuning Abingdon - green . . . CRST153 £2.00
- Negative earth sticker CRST113 £1.36
- Unipart filter sticker CRST119 £1.40
- Tudor water bottle sticker CRST124 £1.50
- Triplex screen sticker CRST125 £1.70
- 4 British Leyland house sticker CRST126 £1.25
- Lucas coil sticker CRST156 £2.30
- 5 Leyland Special Tuning sticker CRST110 £1.45



1

2

CHASSIS PLATES

- Austin Morris group chassis plate* CRCP339 £4.90
 - 1 Commission plate* CRCP301 £4.90
 - 2 Engine number plate (blank)* CRCP343 £1.80
- *(It is up to the purchaser to stamp the correct numbers onto the plates).



REPLICA BROADSPEED NAME PLATE

- Broadspeed name plate CRCP384 £8.70



CLASSIC BADGES

A range of quality badges suitable for both grille and badge bar mounting.

- 1 BMC Drivers Club GAC9967X £91.80
- 2 British Motor Racing Marshalls Club GAC9987X £81.60
- 3 British Racing and Sports Car Club GAC9969X £26.90
- 4 BARC Brooklands GAC9966X £26.90
- 5 England Union flag toothed GAC8043X £34.40
- 6 St. Christopher GAC9970X £71.90
- 7 RAC diamond GAC9971X £38.20
- 8 RAC round laurel GAC1028X £61.20
- 9 RAC toothed GAC8045X £34.40
- 10 UK mainland 105-432 £8.00
- 11 Union chequered flag (42 x 24mm) DAG000070MMM £15.00
- 12 Union flag screw fit (30 x 50mm) GAC4100 £7.80
- 13 Union flag screw fit (35 x 57mm) - chrome GAC4101 £13.50
- 14 Union flag stick on (pair) CRST186 £4.90
- 15 Union flag magnetic MM215-330 £11.00
- 16 Union flag 'flying' DAG000080MMM £21.80
- 17 Union flag stick on - chrome GAC4100CR £10.00
- 18 GB letters stick on - chrome MRD1034SA £13.20
- 19 GB letters set 3 piece - chrome MRD1034A £10.70



UNION FLAG ROOF DECAL

Create an unmissable patriotic statement with this high quality Union flag roof decal. Essential for those continental jaunts. For white roof cars only.

- Union flag roof decal DAF105120 £77.90



BADGES (MKI & MKII)

An important feature for any retro conversion, these badges are just a few of the most popular of the total fitted to the Mini during its long history. An array of different badges were fitted to both Morris and Austin Minis during their production.

- 1 Austin Cooper and S bonnet badge (MkI) 24A71 £11.20
- 2 Morris Cooper and S bonnet badge (MkI) 24A72 £28.00
- 3 Morris Mini bonnet badge (MkI) ADA3580 £40.00
- 4 Austin bonnet badge insert (MkI) 24G1201 £11.70
- 5 Austin bonnet badge insert surround (MkI) 14A6837 £21.00
- 6 Austin Cooper S bonnet badge insert (MkII) ALA6514 £12.60
- 7 Morris Cooper S bonnet badge insert (MkII) ALA6515 £13.00
- 8 Austin/Morris Cooper S bonnet badge surround (MkII) ALA6519 £10.50
- 9 Austin script boot badge (MkI) 14A6802 £12.10
- 10 Cooper script boot badge (MkI) 24A23 £8.20
- 11 Mini script boot badge (MkI) 24A997 £8.75
- Seven script boot badge 14A6853 £8.50



BADGES (MKIII ON)

- 1 Bonnet badge - blue/silver CZH1305 £21.50
- 2 Bonnet badge (to VIN 349159) - silver/black . . CZH4378 £33.00
- 3 Mini word bonnet badge (VIN 463577 to 493180) . DAB10076 £34.20
- 4 Cooper bonnet badge DAH10036 £14.00
- 5 Cooper S boot badge (MkIII) CZH1381 £15.30
- 6 Winged Mini boot badge (1997 on) DAH100590MMM £15.00



- 12 S script boot badge (large) 24A1402 £9.20
- 13 S script boot badge (small) 24A1401 £9.20
- 14 Morris Cooper script boot badge 24A24 £35.00
- 1000 script boot badge ALA6695 £15.00
- 15 1275 script boot badge ALA6696 £12.40
- 16 Cooper S boot badge insert (MkII) ALA6536 £13.20
- 17 Austin Cooper boot badge insert (MkII) ALA6538 £12.10
- 18 Morris Cooper boot badge insert (MkII) ALA6537 £17.50
- 19 Cooper S boot badge surround (MkII) ALA6542 £16.00
- 20 'Mk' script boot badge (MkII) AVB191 £4.00
- 21 'II' script boot badge (MkII) AVB192 £4.20



DECALS FOR INJECTION MINIS

- Mini Cooper rear panel laurel - black DAF10380PMA £5.90
- Mini Cooper rear panel laurel - white DAF10380NMN £6.50
- Side tape - white DAE10119NMN £43.90



COOPER BONNET STRIPES

- No Mini Cooper should be without them, they instantly create that famous Cooper look. These high quality bonnet stripes are available in white.
- Bonnet stripe RH (each) - white DAF10402NMN £42.40
 - Bonnet stripe LH (each) - white DAF10403NMN £42.40



CARPET & CARPET SETS

We have a range of quality carpet sets in a variety of colours that are manufactured to high standards ensuring an excellent fit. Often using materials superior to those used for the original carpets. Where required, some of our carpet sets are moulded to follow the contours of the floor pan as per the originals.

We also offer underfelt kits, competitively priced budget carpet sets for some models and replacement carpet sections, footwell mats, and fittings. Check your model for full details.

See page A52 for more information



HIGH CAPACITY FUEL PUMPS

Facet pumps ensure constant fuel flow and pressure even at high temperatures eliminating the problems associated with vapour lock.

The standard fuel pump may not be able to maintain adequate fuel flow and pressure at higher speeds, particularly with a tuned engine.

Facet fuel pumps are suited to all standard and modified engines fitted with carburettors.

Available in a variety of specifications to suit

the engine's fuel pressure and flow needs.

With safety in mind we recommend fitting a fuel pump inertia switch kit, so that in the event of an accident fuel delivery is automatically cut off.



See page A25 for more information

GRILLES & FITTINGS

The MkI grille is one of the Mini's most striking features. The style of the slats with the moustache surround really shows off the shape of the front end. It was designed to flatter the front and that style was lost with the introduction of the MkII grille assembly. Now you can recreate that look with great ease.



14A7781

14A7299

GRILLES (MKI)

24A2158

- Austin grille (MkI) 14A7299 **£86.00**
- Austin Cooper grille (MkI) 24A198 **£82.00**
- Morris Cooper grille (MkI) 24A2158 **£78.00**
- Morris Cooper full slat grille internal release (MkI) . 24A2159 **£75.00**
- Moustache grille surround 14A7781 **£90.00**
- Grille surround fitting kit 14A7781FK **£6.00**
- Moustache end piece righthand 14A7782 **£10.00**
- Moustache end piece lefthand 14A7783 **£10.00**
- Left and right end mouldings clip ADA3583 **£0.60**



ALA6654Z



DHB10150PME

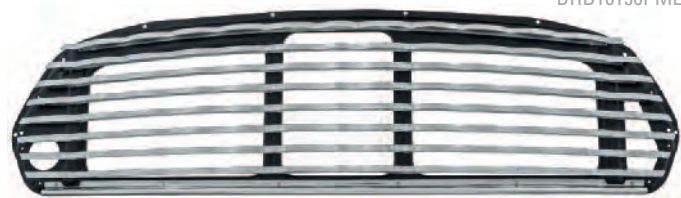

8B12508

GRILLES (MKII ON)

- Chrome grille aftermarket (to 1977 and Mini 30) . . ALA6654Z **£58.00**
- Black grille (1976-82) DHB10150PME . **£60.00**
- Cooper grille (Cooper 1300 + SE) ALA6668 **£63.70**
- Cooper grille internal release (Cooper MkII) . . . ALA6669 **£54.00**
- Cooper s/s grille external release (Cooper MkII) . 8B12504 **£75.00**
- Cooper s/s grille internal release (Cooper MkII) . 8B12505 **£75.00**
- Austin wavy s/s grille external release (MkII) . . . 8B12507 **£82.00**
- Austin wavy s/s grille internal release (MkII) . . . 8B12508 **£80.00**



GAC8420X

GRILLES WITH INTEGRATED LAMP KIT (MKII ON)

As an alternative to spot lamps bolted in front of the grille, we offer this Cooper MkII style of grille with the spot lamps recessed into the grille itself. Available in a complete kit or separately with internal and external bonnet release. The spot lamps are also available separately just in case you need to replace one.

“The grille is one of the Mini's most striking features”

- Grille with spot lamp kit inc. 8B12502 (to 1992) . . GAC8434X . . . **£123.70**
- Grille with spot lamp kit inc. 8B12503 (1992 on) . GAC8420X . . . **£123.70**

- Cooper stainless steel grille (Cooper MkII) 8B12502 **£96.00**
(With 6" holes for spot lamp fitment, external bonnet release access).
- Cooper stainless steel grille (Cooper MkII) 8B12503 **£98.00**
(With 6" holes for spot lamp fitment, internal bonnet release access).

- Spot lamp for grille 8B12502 and 8B12503 (each) . RL020 **£29.80**

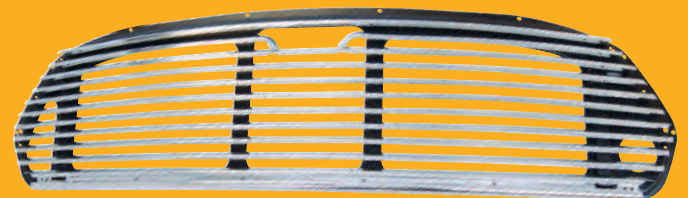

HMP841003



GRILLE KIT (MKIII-IV)

This kit is based on the MkIII and MkIV grille (ALA6654Z) it also contains the grille finisher set (HMP841009).

- Grille kit (MkIII-IV) HMP841003 . **£102.50**

COOPER GRILLE KIT

This kit comprises of a Cooper grille (ALA6669) and the grille finisher set (HMP841009).

- Cooper grille kit HMP841002 . **£102.50**



GRILLE FINISHER KIT

Supplied as a set of 3 mouldings, 1 bonnet and 2 side finishers.

- Grille finisher kit HMP841009 . . **£44.40**



GRILLE BUTTONS

Grille buttons allow easy access to the engine by replacing the dozen or so self tapping screws which are used to hold the grille in place.

- Grille buttons (pair) GAC8421X **£9.70**



WPA9036X



WPA9015X



WPA9012XB



WPA9056X

BURR WALNUT DASH FASCIAS

In 1989 the Smith gauge binnacle was replaced by units manufactured by Nippon Sieki. We can offer fascias for both types of gauge binnacle. Listed below are a range of dashboard assemblies for Nippon Sieki gauges, on which we can also offer an option of chrome rings around the gauge aperture for the 3 gauge binnacle assembly. For pre 1989 models, at present we can only offer the centre binnacle 3 gauge dashboard.

Centre binnacle

- Dash fascia 3 gauge centre binnacle WPA9012X . . .£175.00
- Dash fascia 3 gauge centre binnacle (1 piece) . . . WPA9012XB £175.00

Offset binnacle with chrome rings

- Dash fascia 2 gauge binnacle RHD WPA9056X . . .£175.00
- Dash fascia 2 gauge binnacle LHD WPA9057X . . .£175.00
- Dash fascia 3 gauge binnacle RHD WPA9036X . . .£175.00
- Dash fascia 3 gauge binnacle LHD WPA9037X . . .£175.00

Offset binnacle without chrome rings

- Dash fascia 3 gauge binnacle RHD WPA9015X . . .£175.00
- Dash fascia 3 gauge binnacle LHD WPA9016X . . .£175.00



WPA9040X

WPA9047X

BURR WALNUT HANDLES

You have the burr walnut dashboard, so why not complete the luxury look with one or all of the following window winder and door opening handles, suitable for cars from 1969 on, and for 1983 on cars, interior door pulls. Finish the interior off with a matching gear knob.

- Window regulator handles (1969 on) WPA9042X . . .£58.00
- Door release handles (1969 on) WPA9040X . . .£60.00
- Door pulls (1983 on) WPA9041X . . .£60.00
- Gear knob - plain WPA9047X . . .£26.00



BURR WALNUT CAPPINGS

Many classic coach built Minis were particularly well loved for their opulent interiors. Although we are not able to offer such interior conversions, we can offer a range of high quality Walnut accessories to enhance the interior of your pride and joy. The door capping set contains 4 carefully matched pieces of wood. Suitable for all models.

- Door capping set WPA9017X . . .£177.20
- Screw door capping set (10 required) 517710 £0.32

CENTRE CONSOLES

These centre consoles tidy up your interior and also hide the heater motor. See our website for more details.

- Burr walnut with vents & radio (to 1994) RHD . MT9520 £60.00
- Burr walnut with vents & radio (to 1994) LHD . MT9520L £235.40
- Burr walnut with vents & radio (1994 on) RHD . MT9521 £226.50
- Burr walnut with vents & radio (1994 on) LHD . MT9521L £202.80
- Black vinyl with vents & radio (to 1994) RHD . . MT9524 £60.00
- Black vinyl with vents & radio (to 1994) LHD . . MT9524L £122.16
- Black vinyl with vents & radio (1994 on) RHD . MT9525 £117.60
- Black vinyl with vents & radio (1994 on) LHD . . MT9525L £110.20

ARMREST

No fixing required, this armrest slots between the front seats and includes a storage area over the handbrake, making longer journeys more comfortable.

- Vinyl armrest - black MT9536 £20.00

SPEAKER PODS

- Front footwell speaker pods 5.25" holes (pair) - black . MT9531 £51.20
- Front footwell speaker pods 6.5" holes (pair) - black . . MT9532 £51.20
- Under rear seat speaker board 6.5" holes - black . MT9534 £20.00



MT9520

MT9531

MT9536

Note: Burr walnut is quite dark, being sourced from a naturally growing product, colours can vary. They are carefully matched, but colour variance is possible.



KEYLESS ENTRY KIT

Our keyless entry kit connects to our central door locking system to facilitate remote locking and unlocking of the doors. A useful security feature is that the unit locks the doors when the ignition is switched on, thereby preventing undesirables getting in. Will only fit Minis from 1976 on and cannot be activated remotely by standard Rover alarm systems.

Keyless entry kit
WPA9224X **£100.40**



CENTRAL LOCKING KIT

Central door locking is a key feature of most modern cars, sadly lacking however, on Minis. Our kit has been specifically designed to fit neatly in the door frame without bulging the interior trim of the door skin.

This kit includes fittings hardware and wiring, it can be fitted with the electric window kit. Cannot be activated remotely by standard Rover alarm systems.

Central locking kit
WPA9221X **£122.00**

Note: In some cases only part of the kit is shown.



ELECTRIC WINDOW KIT

Electric windows are one of those must have luxury items, so why not the Mini? It just so happens we can help you out. Unlike many other kits on the market, which are basically universal fitting, the Moss kit is custom designed for installation in MkIII and later doors.

The kit includes two new window lift mechanisms complete with motors, two switch pods (which cover the hole where the window winder spindle popped through) and all necessary fittings, wiring and full instructions. One day's labour and you will enjoy the satisfying whir as your windows glide effortlessly up and down.

Electric window kit WPA9220X .. **£270.00**



ALARM & IMMOBILISER

Alternatively you can install our alarm kit which has been designed to ease fitment and reduce the amount of cutting and splicing of your car's wiring loom. Only fits Minis from 1976 on and cannot be activated remotely by standard Rover alarm systems.

Specification: 127dB six tone siren, 2 key ring programmable transmitters, triggered by shock and opening of doors, bonnet or boot lid dual zone shock sensor back-up battery starter motor immobiliser.

Alarm and immobiliser kit WPA9222X .. **£150.00**



FOOTWELL LIGHT KIT

This LED kit allows fitting extra courtesy lamps in your car, ideal for illuminating the footwells. The simple kit can be connected to any 12 volt system and includes two LEDs, wiring harness and instructions.

Footwell light kit 12 volt
903-651 **£34.50**



POWER WINDOW MODULE

If you have fitted our electric windows kit and either our keyless entry or alarm system, this neat gadget will close the windows if left open when you arm the system. Cannot be activated remotely by standard Rover alarm systems.

Power window module
WPA92221X **£38.20**



AUXILIARY SWITCH PLINTH

3 switch holder as fitted to Minis in the 80's to house the fog light switch. Mounts out of the way under the lower dash and is perfect for those extra switches.

Switch plinth
24G6617 **£4.56**



RED START BUTTON

This illuminated red start button gives your classic a performance car feel. To prevent theft, your key is still required to switch on the ignition and unlock the steering column. Fitting instructions are included.

Red start button
101-180 **£17.00**



PRO START PUSH BUTTON

Add a race car feel to starting your classic with the pro start push button. Easy to fit with no cutting of wires required. The LED type illuminates green with the ignition on and goes out when the engine is running.

Pro start push button GAC0060 **£36.40**



GAE125X



GAE130M



GAE150X



LUSIB748

MT9102



GAE130A



GAE124X



GAE129M



GAE127X



GAE120



GAE122



GAE128X



GAE128M

AUXILIARY GAUGES

Custom build your own dash assembly with these gauges or add them as auxiliary instruments to a wooden dash board. Gauges are supplied with bulb holders and retaining brackets. We offer a range of new gauges in the classic Smiths style with either black or magnolia face with contrasting lettering and an angle section chrome bezel.

Tachometers (80mm diameter)

- 0-7000 tachometer full face 80mm - blackGAE125XNCA
- 0-8000 tachometer full face 80mm - magnolia . . .GAE130M . . £159.30
- 0-10000 tachometer full face 80mm - blackGAE130A . . £165.80

Water temperature & oil pressure gauges (52mm diameter)

- Water temperature °C electric - black GAE124X . . . £53.30
- Water temperature °C electric - magnolia GAE124M . . .£55.40
- Thermal transmitter for electric gauges GTR101 £6.00
- Oil pressure psi - blackGAE123X . . . £89.50
- Oil pressure psi - magnoliaGAE123M . . .£94.30
- Oil pressure switch standard GPS133£3.68
- Oil pressure switch early warning (20psi)TT2998£29.20
- Oil temperature °C - blackGAE129X . . . £64.00
- Oil temperature °C - magnoliaGAE129M . . .£73.40
- Thermal transmitter oil temp negative earth GAE129SENDER .£24.00

Dual gauges (52mm diameter)

Dual gauges are full face with oil pressure and water temperature shown. These gauges use a capillary transmitter pipe (supplied with Gauge) for water temperature and nylon hose for oil pressure.

- Dual gauge °F & psi - blackGAE127X . . .£162.00
- Dual gauge °C & psi - black LUSJB100 . . .£93.00

Oil pressure gauge fittings

- Y piece on engine block LUSIB748 . . .£5.20
- Nylon hose for oil pressure gaugeLUSIB703 . . .£13.90

Oil pressure gauge fittings

- Hose for oil pressure gauge, braided stainless steel . . GLL995120 . .£30.50
- Oil hose sealing washer (2 required)2K4936£0.28

Ammeters & volt meters (52mm diameter)

- Ammeter dynamo models - blackGAE120 . . . £54.40
- Ammeter alternator models - black GAE121 . . . £52.70
- Voltmeter - blackGAE122 . . . £50.00
- Voltmeter - magnoliaGAE122M . . .£55.40

Time clocks (52mm diameter)

- Clock - blackGAE128X . . . £90.00
- Clock - magnoliaGAE128M . . .£85.00

Lucas auxiliary gauges (52mm diameter)

- Water temperature gauge full face capillary LUSIB422 . . .£85.00

Boost gauges (52mm diameter)

- Boost gauge -15 to +30 psi - blackGAE150X . . . £98.70
- Boost gauge -15 to +30 psi - magnoliaGAE150M . . .£98.70



GAC8460X
(Gauge not inc.)



GAC8461X

Gauge mounting pods and plinths

A neat way to fit these gauges into your car. The gauge plinths are pressed steel finished with a crackle finished paint.

- Gauge plinth for tachometer onlyGAC8460X . . . £8.30
- Gauge plinth for tachometer & single gaugeGAC8461X . .£10.50
- Gauge plinth for single gaugeGAC8468X . . . £9.80

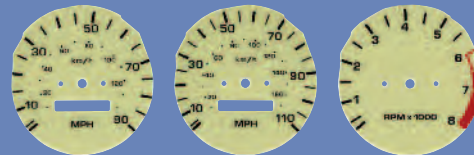

MT9501M

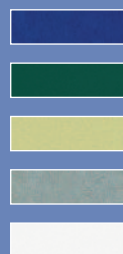

GAUGE FACE KITS

These coloured replacement dial faces fit Nippon Seiki gauges fitted to 1989 on models. Contains a full set of faces including the tachometer.

- Gauge face kit - blue MT9501B . . .£25.90
- Gauge face kit - greenMT9501G . . .£25.90
- Gauge face kit - magnoliaMT9501M . . .£26.50
- Gauge face kit - silverMT9501S . . .£25.90
- Gauge face kit - white MT9501W . . .£25.90

BINNACLE KIT & GAUGES

The centre binnacle is essential to any retro conversion. Our kit contains everything you will need to convert to the centre binnacle layout, including binnacle, finisher moulding, wiring harness, dash liners and parcel shelf liner and hardware. The kit is available with the option of either black or magnolia gauges. Note: The speedo is calibrated for Cooper models and may require re-calibrating to suit your car.



GAC8453X

Centre binnacle kit - black gauges GAC8453X . .£450.00
 Centre binnacle kit - magnolia gauges GAC8453M . £450.00



Binnacle components and gauges are also available separately

3 clock centre binnacle 24A2702 £34.30
 Binnacle finisher moulding 14A9907 £18.00
 Trim to binnacle clip (14 required) 14A9796 £1.60
 Loom conversion centre binnacle AN133D £26.10
 130mph speedo Cooper S - black 13H4442 £189.00
 130mph speedo Cooper S - magnolia 13H4442M . .£194.40
 200kph speedo Cooper S - black 13H4444 £182.20
 200kph speedo Cooper S - magnolia 13H4444M . .£265.00
 Oil pressure - black 13H4459 £81.00
 Oil pressure - magnolia 13H4459W . .£70.50
 Water temperature - black 13H4460 £52.50
 Water temperature - magnolia 13H4460W . .£46.90

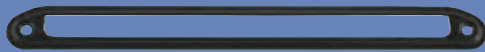

DEMISTER VENT ESCUTCHEON

These demister trims are perfect for that complete restoration. Mounted to the top of the metal fascia where the ashtray is, they are suitable for early cars only without the padded top dash rail. Supplied in black primer or chrome.

Demister vent, black, each 14A9949 £9.00
 Demister vent, chrome, each 14A9949C £14.00

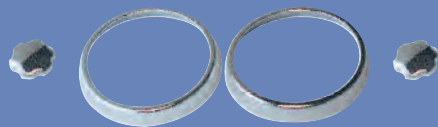

CHROME AIR VENT COVER SET

This chrome air vent set looks great and adds a touch of style, it includes vent surrounds and adjuster knob covers.

Chrome air vent cover set MT9301 £9.00



GAE156

SMITHS CLASSIC ELECTRONIC GAUGES

These new Smiths Classic digital speedos and tachos are designed for heritage cars and are the perfect way to bring modern technology into your much loved classic. If your car does not have an electronic speedo output, our speedo sensor kit (GAE1551) will also be required, which senses a magnetic object, such as a bolt head or a nut, moving past the end of the sensor, creating a 'pulse' which is sent to the gauge and then translated. Please Note: Suitable for negative earth cars only.

Gauge, speedo, electronic, 140MPH, black GAE155 £210.20
 Gauge, speedo, electronic, 0-240kph, 100mm . . GAE157 £205.00
 Gauge, tacho, electronic, 0-7000rpm, black, 100mm .GAE156 £164.00
 Gauge, speedo, electronic, 0-140mph, 80mm . . GAE165 £264.00
 Gauge, speedo, electronic, 0-240kph, 80mm . . . GAE167 £264.00
 Gauge, tacho, electronic, 0-7krpm, 80mm GAE166 £205.00
 Sensor, speedo, electronic GAE1551 £67.60



STAINLESS STEEL MIRROR

Replace the Mini's standard 'bulky' plastic rear view mirror with this beautifully made stainless steel mirror. It's sleek design is not only a joy to look at but also a joy to use.

Stainless steel rear view mirror MT9141 £28.00



8D2490

24A1538

CHROME ASHTRAYS

Ashtrays were fitted to the fascia and in the rear compartments. We offer the original slotted type, or the later flat type.

Chrome ashtray slotted lid 8D2490 £15.00
 Chrome ashtray flat lid 24A1538 £15.00

SEAT BELTS & HARNESSSES



All the belts and harnesses we supply are manufactured in the UK to exacting standards. The replacement belts and harness kits are sold individually. Harnesses do not contain shoulder pads, these must be purchased separately.

We can offer the Securon range of belts in black, red, grey, beige or blue. Below we list just the black and red options; you can find our full range of colours on our website.

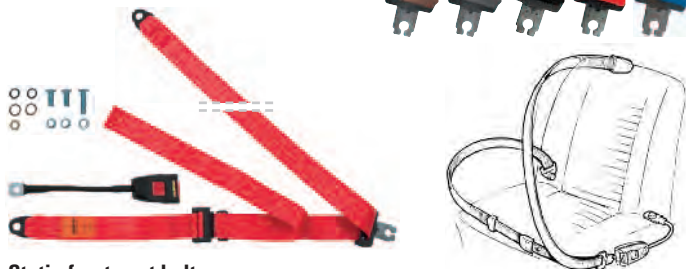

Static front seat belts

- Static seat belt kit - black SBS300/30 **£29.40**
- Static seat belt kit - red SBS300/30RED . . **£38.80**



Automatic front seat belts

- Automatic seat belt kit - black SBS500/30 **£47.40**
- Automatic seat belt kit - red SBS500/30RED . . **£62.40**



Static rear seat belts

- Static 3 point seat belt - black SBS200 **£26.00**
- Static 3 point seat belt - red SBS200RED **£36.00**



- Static lap seat belt - black SBS210 **£20.90**
- Static lap seat belt - red SBS210RED **£30.60**



Automatic rear seat belts

- Automatic 3 point seat belt - black SBS254 **£51.00**
- Automatic 3 point seat belt - red SBS254RED **£60.60**



Seat belt extender

Can be used to safely extend the seat belt if required. 'E' approved for road use.

- Seat belt extender - red SBS227 **£19.50**



Harness kits for road use - 'E' approved

These belts feature 2" webbing with bolt through plate mountings (use with bolts TT7969). Fully adjustable lap and shoulder straps with compact buckle catch. 'E' approved for road use.

- 3 point harness kit - black SBH628BLACK . . **£37.50**
- 3 point harness kit - red SBH628RED . . . **£37.50**
- 4 point harness kit - black SBH629BLACK . . **£36.50**
- 4 point harness kit - red SBH629RED . . . **£36.50**



These belts feature 2" webbing with clip-in snap hook mountings (use with eye bolts TT7967). Fully adjustable lap and shoulder straps with load spreaders on lap belts and a compact buckle catch. 'E' approved for road use.

- 3 point harness kit - black SBH605BLACK . . **£45.00**
- 3 point harness kit - red SBH605RED . . . **£45.00**
- 3 point harness kit - blue SBH605BLUE . . . **£45.00**
- 4 point harness kit - black SBH655BLACK . . **£51.00**
- 4 point harness kit - red SBH655RED . . . **£51.00**
- 4 point harness kit - blue SBH655BLUE . . . **£51.00**



Retractor reel 3 point harness

This 3 point harness features a retractor reel on the over-shoulder strap allowing movement within the seat. The reel works in the same way as a standard automatic belt engaging the locking mechanism if required.

- 3 point retractor harness - black SBH700BLACK **£76.20**



CLASSIC TRACKER AND IMMOBILISER

Classic Tracker provides a secure and reliable tracking service dedicated for classic cars and motorcycles! A three-wire, self-install tracker which uses GPS & GSM to establish and maintain the secure-status of your classic. In the event of any unauthorised movement or tampering, you receive an alert via app/SMS/email and have access to real-time information on an app or the web. An immobilizer is provided so you can remotely immobilise your car during a theft situation just by accessing the app on your phone or on the web. The Immobiliser Pack involves connecting a relay across either your vehicles' ignition or electric fuel pump which is controlled via a fourth wire from the tracker. Classic Tracker 'Safer' pack contains: Tracker unit, Immobiliser pack and one year subscription. After the subscription ends you have the option to renew it or cancel it, if you decide to renew it the annual subscription fee is £99.00 per year. DIY installation is straight forward and can be installed in less than 2 hours, however if you're not sure we recommend installation by a professional.

Classic Tracker TRACKER1 . £299.00



SEAT HARNESSES FITTINGS

Harness back strap adapter (pair) TT7972£9.80
 Eye bolts (pair) use with clip-in mountings TT7967£12.00
 Bolt & spacer (pair) use with plate mountings TT7969£6.40
 Nut plates (pair) reinforced for fixing bolts TT7968£9.60



HANDBRAKE GRIP

Smarten up the Mini's handbrake. It will make handbrake turns even more fun.
 Handbrake grip FAM8356£8.20

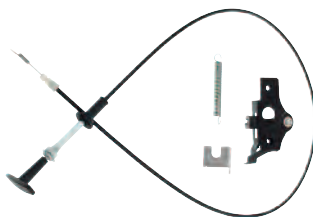

BONNET RELEASE KIT

As fitted to the very latest range of Minis, we have the cable operated bonnet release kit.
 Cable bonnet release kit GAC8425X . . . £32.00



STEERING COLUMN DROP BRACKET

This drop bracket lowers the angle of the steering column for a more comfortable driving position, especially when the seat is lowered or moved.

Steering column drop bracket (non airbag to 1996) . .GAC8426X £3.60

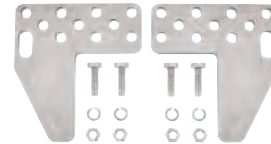

SEAT RUNNER EXTENSION

Specially for the taller Mini driver, just because you are tall doesn't mean you can't drive your Mini in comfort.

Seat runner extension (pair) GAC8427X £5.50



12 VOLT POWER SOCKET

This 12 volt supply or cigar lighter is a useful addition to your classic's interior. It is suitable for use as a 12 volt power socket for in-car accessories such as Sat Nav or simply for lighting your cigars.

Cigar lighter AHH7010£18.65
 Bracket under dash mounting AHH7010BKT . £4.75

GAC8428X



900-315

THROTTLE PEDALS

Whether you choose the Paddy Hopkirk or plain extension pedal is up to you, they are both specifically designed to aid heel and toe shifting.

Paddy Hopkirk pedal extension 900-315£38.95
 Throttle pedal extensionGAC8428X £7.00

MT9311



MT9312

DOOR SILL TREAD PLATES

Protect the door step as you get in and out with these highly polished stainless steel tread plates. Available in two designs these sill plates also are easy to fit.

Stainless steel with Mini and chequered text . . . MT9311 £26.90
 Stainless steel with Mini Cooper & chequered text . MT9312 £28.00

MOTO-LITA STEERING WHEELS

Moto-Lita

Moto-Lita are among the finest replacement steering wheels available. Designed to enhance the appearance of the cockpit and provide an improved feel for the driver. Available in a variety of styles, materials and sizes to suit, please see our website for the full list of options. All steering wheels listed feature drilled spokes, except where detailed.

Wood rimmed steering wheels

- Mk3 flat polished spokes 13" MLW1115-13 ..£177.50
- Mk3 flat polished spokes 14" MLW1115-14 ..£177.50
- Mk3 flat polished spokes 15" MLW1115-15 ..£177.50
- Mk3 dished polished spokes 13" MLW1116-13 ..£177.50
- Mk3 dished polished spokes 14" MLW1116-14 ..£177.50
- Mk3 dished polished spokes 15" MLW1116-15 ..£177.50
- Mk3 flat polished spokes with thin slot 14" . . MLW1120-14 ..£177.50
- Mk3 flat polished spokes with thin slot 15" . . MLW1120-15 ..£177.50
- Mk3 flat polished spokes with wide slot 15" . . MLW1122-15 ..£177.50

Leather trimmed steering wheels

- Mk4 flat polished spokes 12" MLW1111-12 ..£177.50
- Mk4 flat polished spokes 13" MLW1111-13 ..£177.50
- Mk4 flat polished spokes 14" MLW1111-14 ..£177.50
- Mk4 flat polished spokes 15" MLW1111-15 ..£177.50
- Mk4 flat black spokes 13" MLW1112-13 ..£177.50
- Mk4 flat black spokes 14" MLW1112-14 ..£177.50
- Mk4 flat black spokes 15" MLW1112-15 ..£177.50
- Mk4 dished polished spokes 13" MLW1113-13 ..£177.50
- Mk4 dished polished spokes 14" MLW1113-14 ..£177.50
- Mk4 dished polished spokes 15" MLW1113-15 ..£177.50
- Mk4 dished black spokes 13" MLW1114-13 ..£177.50
- Mk4 dished black spokes 14" MLW1114-14 ..£177.50
- Mk4 dished black spokes 15" MLW1114-15 ..£177.50

Mahogany rimmed steering wheels

- Mk9 flat polished spokes 14" MLW1119-14H ..£226.50
- Mk9 flat polished spokes 15" MLW1119-15H ..£226.50



MLW1115-13

MLW1120-14

MLW1113-13

MLW1112-13

MLW1122-15

MLW1119-14H



MLW1117BHP

MLW1117X1

MLW1117X2

MOTO-LITA ACCESSORIES

Moto-Lita

- Billet centre cap 3.5" MLW1117BCC.. £48.00
- Billet horn push 3.5" MLW1117BHP.. £90.00
- Moto-Lita centre cap MLW1117X1 . . . £11.15
- Centre cap and horn push MLW1117X2 . . . £20.00
- Polished ring kit MLW1117X3 . . . £13.00
- Black ring kit MLW1117X3B . . £13.00



Tourist Trophy centre cap

Replace your Moto-Lita centre cap/horn push with one of our Tourist Trophy direct replacements. Featuring a large chrome & enamel marque badge. If your car has the horn push on a stalk please use the Tourist Trophy horn push/centre cap supplied as a centre cap, keeping your existing horn push on the stalk.

- Tourist Trophy centre cap/horn push 905-649 £21.70



MLW1117B1HM

MLW111725M

MOTO-LITA ADAPTOR BOSSES

Moto-Lita

- Moto-Lita horn push for single stalk (1958-66) MLW1117B1HM. £66.30
 - Moto-Lita non horn push for single stalk (1966-69) . MLW1117B1M . .£66.30
 - Moto-Lita for single stalk (1969-75) MLW111725M . £66.30
 - Moto-Lita for twin stalk (1976 on*) MLW111745M . £66.30
- (*Note: On later cars from 1989 on there is only one indicator cancelling pin, match the boss to the existing wheel and remove the unwanted pin).



CUP HOLDER

This extremely useful folding cup holder can be mounted almost anywhere inside your car. The arms adjust in or out to suit the size of your container and folds up when not in use to give a neat appearance.

- Expandable cup holder 222-090 £10.50



ALLOY INTERIOR DOOR HANDLE SET

A stylish way to enhance your Mini's interior, supplied as a complete set with window winders, door release handles and door pulls.

Alloy interior door handle set GAC4605 **£57.95**



CHROME INTERIOR HANDLE SET

Enhance the appearance of your Mini with these chrome plated interior handles. The set features alternative styles of handle and includes chrome plated fixing screws, where necessary.

Chrome interior handle set (to 1982) WPA9018X **£78.00**



MOMO GEAR KNOBS



For over 30 years MOMO has been developing and producing automotive products to the very highest quality. So renowned for their quality that many manufacturers fit MOMO as an optional upgrade. Whichever gear knob you choose, it is sure to complement your interior.

- 1 Race air leather alloy gear knob MOMO1060 . **£93.00**
- 2 Race air leather gear knob MOMO1057 . **£93.00**
- 3 Anatomic hide gear knob MOMO1050 . **£82.00**
- 4 Aluminium sport gear knob MOMO1054 . **£62.60**
- 5 Competition gear knob MOMO1053 . **£61.90**



GEAR KNOBS

These quality Mini gear knobs are available in leather or wood.

- Leather Cooper gear knob GAC4052C . . . **£11.00**
- Wood Cooper gear knob GAC4053C . . . **£12.50**



GAITER FINISHER KIT

Smarten up your gear stick with this easy to fit universal gaiter finisher kit. Some gaiters may require modification to fit. (Gaiter not included).

Chrome gaiter finishing kit GAC9540 **£18.80**

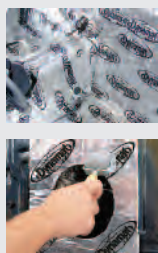

DYNAMAT HEAT & SOUND INSULATION

We now stock Dynamat, a revolutionary range of products designed to keep your classic cool & quiet.

- Non absorbent materials
- Self adhesive 'peel & stick'
- Easily cut & moulded to fit
- Isolates panel vibration
- Reduces road noise
- Reduces heat soak from engine & exhaust

Dynamat Xtreme

A highly efficient, composite material designed to reduce noise, vibration & heat soak through panel work.

- Dynamat Xtreme - speaker pack GAC90511 . . . **£15.80**
(2 sheets of 254mm x 254mm (10" x 10")).
- Dynamat Xtreme - wedge pack GAC90512 . . . **£35.50**
(1 sheet of 457mm x 812mm (18" x 32")).
- Dynamat Xtreme - door pack GAC90513 . . . **£86.50**
(4 sheets of 305mm x 914mm (12" x 36")).
- Dynamat Xtreme - bulk pack GAC90514 . . . **£219.00**
(9 sheets of 457mm x 812mm (18" x 32")).

Dynaliner

Dynaliner is an ultra-light weight, durable single layer insulation material that can be used as an alternative to traditional underfelt. It provides acoustic isolation and excellent thermal insulation.

- Dynaliner - 1/8" thick GAC90531 . . . **£54.50**
(1 sheet of 813mm x 1372mm (32" x 54")).
- Dynaliner - 1/4" thick GAC90532 . . . **£79.00**
(1 sheet of 813mm x 1372mm (32" x 54")).
- Dynaliner - 1/2" thick GAC90534 . . . **£104.20**
(1 sheet of 813mm x 1372mm (32" x 54")).

Hoodliner

Designed specifically for under bonnet insulation, Hoodliner absorbs engine noise to help keep your car quieter. The aluminised skin creates a water & oil barrier that reflects up to 97% of heat to protect the bonnet's paint.

Hoodliner GAC90541 . . . **£85.50**
(1 sheet of 813mm x 1372mm (32" x 54")).



K&N AIR FILTERS

Anyone can flow more air. The trick is to flow more air safely. K&N filters have a reputation as being one of the most efficient air filtration available.

K&N air filters have 4 to 6 layers of cotton gauze sandwiched between two aluminium wire screens. The cotton is treated with a specially formulated grade of oil causing tackiness throughout the cotton. The cotton allows high volumes of airflow, while the

tackiness of the oil creates a powerful filtering media that ensures engine protection.

- Designed to increase horsepower and acceleration
- Washable and reusable



See page A23 for more information



DYNAMAT NOISE & HEAT INSULATION

Two steps to a quieter, cooler, better feeling great car...

Step 1 Dynamat - to deaden the noise

Apply Dynamat to all the accessible interior panels of your car. Dynamat is best for noise reduction with some heat reduction... Start with firewall/bulkheads, gearbox tunnel, front floors, doors, rear floors, roofs, wheel arches, under bonnet, boot lid.

Step 2 Dynaliner - insulates against heat

Apply Dynaliner over the top of Dynamat to reduce heat soak by up to 70%. Also helps with noise reduction.



See page A51 for more information

CARPET SETS

These carpet sets are moulded to follow the contour of the floor pan exactly, to give a quality fit and finish to your car. As any Mini owner is aware it can get very noisy when driving at speed. These carpet sets feature 12mm thick sections of sound deadening laminated to the backing of the carpet to keep the sound levels as low as possible.

These carpet sets include: front wheel arch, front bulkhead, front & rear floor, cross member and sill carpets. Supplied with all fittings and instructions.



CSR9002X

Early carpet sets (to 1973)

To fit MkI-III saloon models with 'magic wand' or remote change gear levers. Carpets are marked with the various hole options on the rear to help position the holes.

- Carpet set - black CSA9002X .. £214.20
- Carpet set - red CSR9002X .. £209.40
- Carpet set - grey CSF9002X .. £214.20

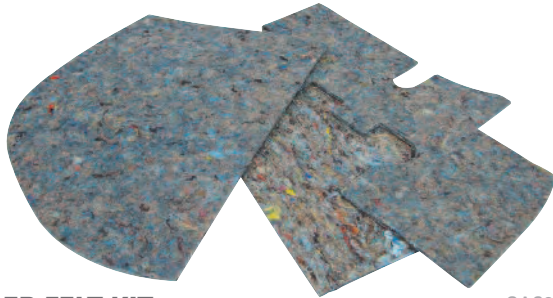

GAC8429X

UNDER FELT KIT

Keeping the noise level down is not easy! Most carpet sets on the market don't have a great deal of backing on them so fitting the under felt fit not only reduces the noise level but also make the carpet feel much nicer under foot.

- Under felt kit pre cut MT9540 £28.50
- Under carpet sound insulation kit GAC8429X £56.20
- Space age heatshield 48" x 72" sheet 409-016 £34.90

GAC9540



GAC8488X



GEAR LEVER GAITER

- Gear lever gaiter - black GAC8488X .. £23.70
- Chrome gaiter finishing kit GAC9540 £18.80



CSF9000X

Late carpet sets (1973 on)

To fit saloon models with rod change gear levers.

- Carpet set - black CSA9000X .. £214.20
- Carpet set - red CSR9000X .. £209.40
- Carpet Set - grey CSF9000X .. £214.20



CSA9002Z

BUDGET CARPET SETS

We can also offer a moulded carpet set produced by the original manufacturer and finished with bound edges. This set does not have sound deadening backing material, but it can be used with the sound deadening kit left.

These carpet sets include: front wheel arch, front bulkhead, front and rear floor and sill carpets. Supplied with all fittings and instructions.

- Carpet set - black CSA9002Z ... £40.00
- Carpet set - red CSR9002Z ... £40.00
- Carpet set - grey CSF9002Z ... £70.00
- Carpet set - blue CSN9001Z ... £43.70



CARPET FITTINGS

- 1 Fastener fitted to floor 610624 £0.56
- 2 Rivet fastener to floor GHF600 £0.13
- 3 Clip on back of carpet 2H8445 £0.37
- 4 Spike ring through carpet pile 14G8736 £0.28

HEADLINING

If your headlining is showing signs of old age, then why not replace it? We can supply a ready stitched vinyl replacement main section with all loops stitched in place. The kit also contains a pair of rear pillar covers in matching material.



HLK3012P

Headlining

- Headlining kit (MkI) - crackle finish creamHLK3000C . .£117.40
- Headlining kit (MkIII) - light greyHLK3012P . .£117.40
- Headlining kit (MkIII) - whiteHLK3012W . £117.40

Headlining rails

Headlining rails provide the material with its shape. They are counted from front to back and are also colour coded for identification.

- Headlining rail number 1 - red EEB100060 . .£15.00
- Headlining rail number 2 & 3 - white EEB100070 . .£15.00
- Headlining rail number 4 - black EEB100080 . .£15.00
- Headlining rail number 5 - blue EEB100090 . .£17.20
- Headlining rail number 6 - yellow EEB100100 . .£15.00

GAC8465X



GAC8484X

SUN VISORS

Made to original standards...

- Sun visor no mirror - black GAC8465X . .£36.00
- Sun visor with mirror - black GAC8466X . .£39.10
- Sun visor fitting kit GAC8467 . .£19.80
- Sun visor (1966-69) - cream GAC8484X . .£36.00



BFK9002X

BOOT FLOOR KIT

Tidy the boot area of your Mini with one of these carpeted wood floors. When installed they provide a flat floor that not only tidies the boot area, but also helps to protect the battery and spare wheel.

- Boot floor kit 5.5 gallon tanks (1974-79)BFK9001X . . £98.60
- Boot floor kit 7.5 gallon tank (1980 on) BFK9002X . . £98.60
- Bracket set (up to 165 section tyres) BFK9004X . . £127.30

SEAT01V



SEAT01

SEAT01HR

SFX COBRA CLASSIC BUCKET SEATS

Cobra are one of the world's most renowned manufacturers of sports application seats. The (low back) classic bucket seat is ideal for the Mini, enabling easy access to the rear, while also giving extra side support.

They are essential for creating that retro style interior, and are available in nylon or vinyl. The nylon seat is also available with a headrest. Specification: Weight 4kg, height 56cm, width 51cm, depth 50cm. **Please note: To fit the Cobra classic seat you will require a Cobra subframe.**

- Low back seat in nylon - black SEAT01 £152.00
- Low back seat with headrest in nylon - black . . . SEAT01HR . .£260.00
- Low back seat in vinyl - black SEAT01V . . .£160.00

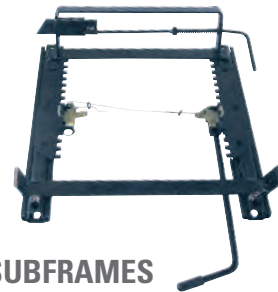

SEAT10RIGHT

COBRA SEAT SUBFRAMES

- Subframe without floor catch/lock (to 1976) . . . SEAT09 £70.00
- Subframe with floor catch/lock LH (1976 on) . . SEAT10LEFT . .£82.00
- Subframe with floor catch/lock RH (1976 on) . . SEAT10RIGHT £82.00
- Seat runner extensions (pair) GAC8427X . . .£5.50



EBF100150

BLL1000X

BOOT TRIM

Tidy the boot area of your Mini with this moulded plastic boot floor liner (not suitable for injected or twin tank cars). Also the boot lid liner really smartens thing up and stops those washers falling into the boot frame never to be seen again.

- Boot lid liner (inc. screws) BLL1000X . . . £19.50
- Plastic boot floor liner EBF100150 . . . £64.00



GAC6904



MFM113

FOOTWELL MATS

Protect the carpets in your Mini with these quality footwell mats featuring bound edges. The tailored fit and non slip backing ensures secure location. Available as a two piece or four piece set.

- Footwell mats no logo (set of 2) (1973 on) GAC6902 **£41.70**
- Footwell mats no logo (set of 4) (1973 on) GAC6904 **£76.01**
- Footwell mats no logo (set of 4) (universal) MFM113 **£30.40**



DPK9000X

DASH LINER KITS

Supplied in black these liner kits improve the appearance of the dash area.

- Central speedo panel kit (speedo in centre) DPK9000X **£53.00**
- Centre binnacle panel kit (3 gauges no vents) DPK9001X **£53.00**
- Centre binnacle panel kit (3 gauges with vents) DPK9002X **£53.00**
- Offset binnacle panel kit (2 & 3 gauge) RHD DPK9003X **£81.60**
- Offset binnacle panel kit (2 & 3 gauge) LHD DPK9004X **£81.60**
- Parcel shelf liner kit (all models) DPK9010X **£52.00**



EDGE TRIM FINISHER

Flexible herringbone pattern edge trim finisher. U section PVC with sprung steel inner. Will grip onto 0.5mm - 3mm thick edge. Available in four different colours with many different uses.

- Edge trim finisher - black 624801M **£3.74**
- Edge trim finisher - blue 624801MB **£5.20**
- Edge trim finisher - red 624801MR **£5.20**
- Edge trim finisher - white 624801MW **£5.20**

TRIM PANEL KITS

Designed to enhance the interior of your Mini, available in black, red or grey (nimbus). These high quality trim panel kits feature a horizontal seam welded design styled on the original Cooper interior trim design. The deluxe kit features a foam backing to the vinyl panels to give a more padded feel.



TKR9000X

MkI & MkII Deluxe trim panel kits

- Deluxe trim panel kit - red TKR9000X **£395.90**
- Deluxe trim panel kit - grey TKF9000X **£395.90**

MkI & MkII Standard trim panel kits

- Standard trim panel kit - black TKA9008X **£428.00**
- Standard trim panel kit - grey TKF9008X **£428.00**

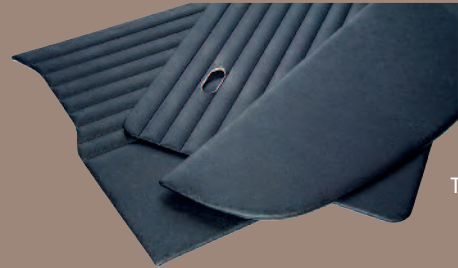

TKA9042X

MkIII Monte Carlo trim panel kits

- Monte Carlo trim panel kit - black TKA9042X **£249.30**
- Monte Carlo trim panel kit - red TKR9042X **£249.30**
- Monte Carlo trim panel kit - grey TKF9042X **£249.30**
- Clip door trim boards (18 per car) GHF1222 **£0.37**
- Door pocket YGA452 **£17.30**



DP3048

TKA9010X

TKA9011X



Door cards only

- Door card wind up window (1976-80) - black . . . DP3048 **£74.20**
- Door card painted (MkI-II) - black TKA9010X **£43.90**
- Door card padded (MkI-II) - black TKA9011X **£80.58**



DOOR POCKET FINISHER

24A1169

For MkI-II models this finisher tidies up the edge of the door pocket.

- Door pocket finisher (MkI-II) 24A1169 **£13.70**
- Clip (4 per trim) EYC10048 **£2.23**



230-390



230-355



230-388

Fitment: Cars must be negative earth. Units supplied without faceplate or knobs.

RETRO SOUND RADIOS

The RetroSound range of radio & MP3 players maintain the original 'twin knob' (DIN-D) style mounting required for many classic cars. Music can be played from external sources such as iPods, USB flash drives & SD cards, all connected out of sight.

San Diego

DAB/DAB+ Tuner (DAB antenna or DAB Antenna Adaptor required), AM/FM Tuner, iPod/iPhone & Android compatible, Bluetooth, x2 rear USB ports & x2 rear Auxiliary inputs. 32,000 colour LCD with built in amp (45 watts peak/25 watts RMS x 4 channels).

- RetroSound San Diego, chrome230-383 **£315.00**
- RetroSound San Diego, black230-388 **£315.00**

Hermosa

AM/FM Tuner, iPod/iPhone & Android compatible, x1 rear USB port & x2 rear Auxiliary inputs. Dual colour LCD display (white and green) with built in amp (45 watts peak/24 watts RMS x 4 channels).

- RetroSound Hermosa, chrome230-390 **£233.60**
- RetroSound Hermosa, black230-395 **£233.60**

Long Beach

AM/FM Tuner, iPod/iPhone & Android compatible, Bluetooth, x2 rear USB ports & x2 rear Auxiliary inputs. 32,000 colour LCD with built in amp (45 watts peak/25 watts RMS x 4 channels).

- RetroSound Long Beach, chrome230-381 **£315.00**
- RetroSound Long Beach, black230-386 **£315.00**

Laguna

Back to the basics with this AM/FM tuner with x1 rear auxiliary input. Adjustable-angle LCD display with built-in amp (40 watts peak/18 watts RMS x 4 channels).

- RetroSound Laguna, chrome230-355 **£175.00**

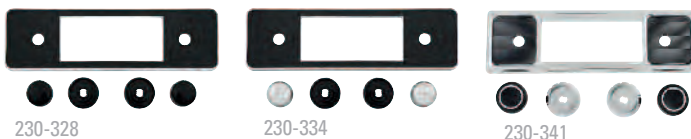

Faceplate and knob kits (F&K kits)

These kits let you finish off your RetroSound radio with the faceplate and knobs that match the original trim of your classic car. Knobs are available on their own as replacements. Please see our website for full range.

- F&K kit - chrome faceplate/chrome knobs230-326 **£33.25**
- F&K kit - black faceplate/black knobs230-327 **£33.25**
- F&K kit - black/black faceplate/chrome knobs230-329 **£33.25**
- F&K kit - black/chrome faceplate/black knobs230-328 **£33.25**
- F&K kit - black/chrome faceplate/chrome knobs230-333 **£33.25**
- F&K kit - black/chrome faceplate/black/chrome knobs230-334 **£33.25**
- F&K kit - Becker pinstripe230-341 **£33.25**
- F&K kit - Blaupunkt black230-342 **£33.25**
- F&K kit - Blaupunkt black/chrome230-346 **£33.25**
- F&K kit - VW ivory230-343 **£33.25**
- F&K kit - Ghia chrome230-344 **£33.25**
- Knob set only - chrome230-331 **£15.74**
- Knob set only - black230-332 **£15.74**



230-505



230-545



230-530



230-550

RETROMOD SPEAKERS BY RETRO SOUND

The RetroMod range of speakers from RetroSound has been designed to compliment their range of Classic radios and have been manufactured to meet the demands of modern high performance amplifiers.

Dual voice coils (DVC) speakers

This system allows for 2 stereo channels (left & right) to be connected to the same single speaker. This means that originality can be maintained on cars where a single speaker was fitted in the centre of the dash or rear shelf. These speakers are supplied individually without mesh grilles, to fit existing mountings.

- 6.5" dia 3 way, DVC, no grilles (each)230-505 **£58.25**
- 5" x 7" 3 way, DVC, no grilles (each)230-545 **£69.40**
- 6" x 9" 3 way, DVC, no grilles (each)230-510 **NCA**

Single voice coils (SVC) speakers

The SVC range of speakers is a standard configuration single channel speaker

for normal installations (left & right mounted speakers, such as doors or dash). These speakers are available in a range of sizes and specifications, see our website.

- 4.5" dia 2 way, 40W max, with grilles (pair)230-535 **£79.60**
- 5" x 7" 3 way, 60W max, with grilles (pair)230-540 **£82.60**
- 6" x 9" 3 way, 100W max, with grilles (pair)230-530 **£73.40**
- 6" x 9" 3 way, 100W max, with grilles (pair)230-531 **£142.80**

RetroMod 8" Subwoofer

The compact design and powerful bass response make this ideal for under seat mounting and numerous other in-car applications. The rigid die cast aluminium chassis and powerful Class D amplifier allows this sub to reproduce low frequencies as low as 35Hz.

- 8" Subwoofer with internal amplifier230-550 **£189.00**



This hide-away amplified aerial can be mounted hidden away, almost anywhere inside the car. Ideal if you don't want to install a wing or roof aerial to keep your classic original.

MRA001 AJM1112X EEP11Z

RADIO AERIALS

Our range of aerials offers a variety of fitting options from wing to roof mountings. The wing mount aerial features adjustable bases to compensate for slight angles off horizontal. The roof mounted aerial features a removable stainless steel mast with a chrome base plate. Aerial extension cable is also available.

- Hide-away amplified aerial230-555£27.00
- Aerial wing mount manualMRA001£10.80
- Aerial wing mount electricAJM1112X£58.00
- Aerial roof mountEEP11Z£12.30
- Extension lead aerial 3 metreZKC533£12.40



ULTIMATE OUTDOOR CAR COVER

The new Ultimate car cover uses specially formulated advanced nanotechnology formula which gives a unique water resistant coating ensuring long term protection. The advanced fabric is fully waterproof, breathable, strong and stretchy. Supplied with storage bag.

Ultimate outdoor car cover GAC95031£220.00



WATERPROOF BLANKET

These waterproof blankets bring a touch of comfort to any roadside picnic. Easily folded into a neat parcel, it can be easily stored and carried with its durable handle. They are manufactured from grey acrylic with a foam layer and waterproof PEVA backing. Size 51" x 70".

Waterproof blanket with Moss logo - grey 231-370£27.35



SWITCH BEZEL TOOL

The round bezels on most Lucas switches have two slots, and nobody has the special tool - a bezel nut spanner - you need to take them off. The set includes tools for 0.75" diameter and 1" diameter bezel nuts and saves you using screwdrivers and other assorted implements that result in scratched dashboards.

Switch bezel tool 384-960£21.20



THERMAL MUGS

These thermal mugs maintain your drinks temperature whether hot or cold. Desk mugs feature a wider design with handle. Travel mugs are designed to suit most in-car cup holders. Both feature a non-slip base and a removable cap.

- Travel mug - Union Jack 230-946£16.80
- Desk mug - Union Jack 230-947£16.80



UNION FLAG

Lightweight polyester with metal grommets on the hoist.

Union flag, 36" x 60" GAC9939X£22.45

PATCHES



Show your allegiance with one, or all of these quality sew-on patches. We also have a selection of iron-on patches available.

- 1 Union flag sew-on patch 229-510£2.57
- 2 British Leyland sew-on patchGAC9960X£4.50
- 3 BMC sew-on patch GAC9961X£4.40
- 4 Mini iron-on patch - red GAC6080X£2.88
- 5 Mini iron-on patch - blackGAC6081X£2.88
- Mini iron-on patch - blue GAC6082X£2.88
- Mini iron-on patch - green GAC6083X£2.88



KEY FOBs

These traditional leather key fobs look good and keep your keys together.

- 1 Union flag key fobGAC4042£3.60
- 2 BMC rosette key fob CRSP401£3.60
- 3 Leyland Mini key fobGAC4043£3.60



OUR BRANCHES ARE HERE TO HELP

No matter which Moss branch you use, you can expect the same quality service. Whether you have an inquiry about a product, or simply want some advice, our staff of like-minded enthusiasts are there to help.

When you have a question don't hesitate to call one of our branches. We look forward to being of service.



Full contact details of our branches can be found on the back cover of this catalogue

BOOKS, MANUALS & DVDS

Our range of publications have been put together after hours of bedtime reading, to bring you a selection of books about the restoring and working on classics that will enlighten the reader. Beware, some of these books may cause you to damage the contents of your wallets and purses in a big way.

We stock the ever popular Haynes range of manuals, these manuals are essential equipment for the home mechanic. While the carburettor and component manuals contain more details than the general workshop manuals. Of course there are also the modification and tuning guides a must for the Mini enthusiast.



Tuning SU carburettors

This book looks into the basic design of the SU carburettor. It covers many areas including overhaul, tuning mixtures, jet and needle identifications and SU fuel pumps.

Tuning SU carburettors MGL0070 £13.95



SU workshop manual

Factory manual covering both carburettors and fuel pumps.

SU workshop manual GAC1044X £8.00

SU needle chart

The chart identifies the correct replacement SU needle when modifications have been carried out to the engine or induction.

SU needle chart ALT9501 £10.00

SU parts catalogue ALT9524 £6.25

Carburettor manual

This Haynes 'techbook' manual covers SU, Stromberg, Weber and Dellorto carburettors. Giving an insight into the way carburettors operate and how to maintain and tune them, as well as including detailed servicing and overhaul procedures.

Carburettor manual MGL0279 £28.00

SU carburettor rebuild DVD

This 2 hour, 40 minute film explains how to rebuild SU carbs.

SU carburettor rebuild DVD . . . 211-036 £37.45

Weber carbs: Tuning tips & techniques, by John Passini

This book is the distillation of many years experience of working with Weber carbs. The mysteries of why and how they work and the practicalities of getting the best from them. Also setting-up, fault-finding, maintenance & repair are all covered.

Tuning tips & techniques 213-431 £11.95

Lucas fault diagnosis manual

This guide presents a logical sequence of tests that may be carried out on starters, generators, regulators, ignition and lighting systems. Written for technicians, this book can be easily understood by the amateur mechanic.

Lucas fault diagnosis manual . . . GAC1029X £4.00

Classic car bodywork, by Martin Thaddeus

A book written for the home restorer who, until now, lacked the confidence to tackle bodywork. With specially devised techniques which don't rely on workshop plant, this work spans the gap between professional and amateur.

Classic car bodywork MGL0330 £25.00

Haynes restoration manual

Restoration manual MGL0265 £22.99

Haynes workshop manuals

Workshop manual (1959-69) . . . MGL6219X . . . £25.00

Workshop manual (1969-01) . . . MGL6220X . . . £22.99

Tuning guide by David Vizard

Tuning BL's "A" series engine . . MGL0063 £25.00

Original series book - Mini Cooper, by John Parnell

This book is the definitive guide to one of Britain's best-loved sports car, the 'Original' series books are indispensable for all owners, restorers, buyers and enthusiasts.

Original series book MGL0254 £35.00

Rule Britannia, by John Nikas

Rule Britannia – When British Sports Cars Saved A Nation; With authoritative text from John Nikas and his team of dedicated researchers and contributors; historic imagery from archives maintained by marque clubs, manufacturers and museums; and modern portraits artfully captured in a studio setting by Michael Furman, the world's most renowned automotive photographer.

Rule Britannia MGL0360 £85.00

How To Restore Classic Car Interiors

The ultimate resource for restoring the interior of your classic car. Produced in close cooperation with the editors of Europe's largest vintage car magazine, OLDTIMER MARKET. Providing easy to follow guidance, helping you make your car interior look as good as new.

How to restore classic car interiors . MGL0364 £25.00

Gold Portfolio for the Mini Cooper (1961-71)

Charting the introduction of the Mini models through contemporary road tests and articles, an essential part of every Mini lover's library. Covers; Austin Seven Cooper, Morris Mini Cooper, Downton, Taurus, Cooper S, Cooper S 1275, Broadspeed Cooper S & Bertone.

Gold portfolio for the Mini Cooper . MGL0320 £18.95

Original Technical Publications (OTP) USB

These publications have been carefully reproduced from the extensive historical archives in both England and the USA. Meaning you have access to the original Heritage publications needed to run and maintain your Heritage vehicle. Including parts catalogues, service manuals and owners literature. USB – Printable, searchable, zoom-able & bookmarked. Limited to 1 device. USB portable – Printable, searchable, zoom-able, bookmarked, offline capable, instant access. Take anywhere.

OTP Mini USB HTP2006E £40.25

OTP Mini USB Portable HTP2006USB . £55.96

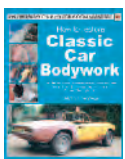
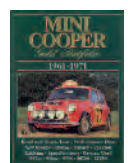
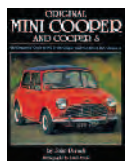
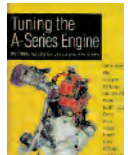

CARBURETTOR MODELS

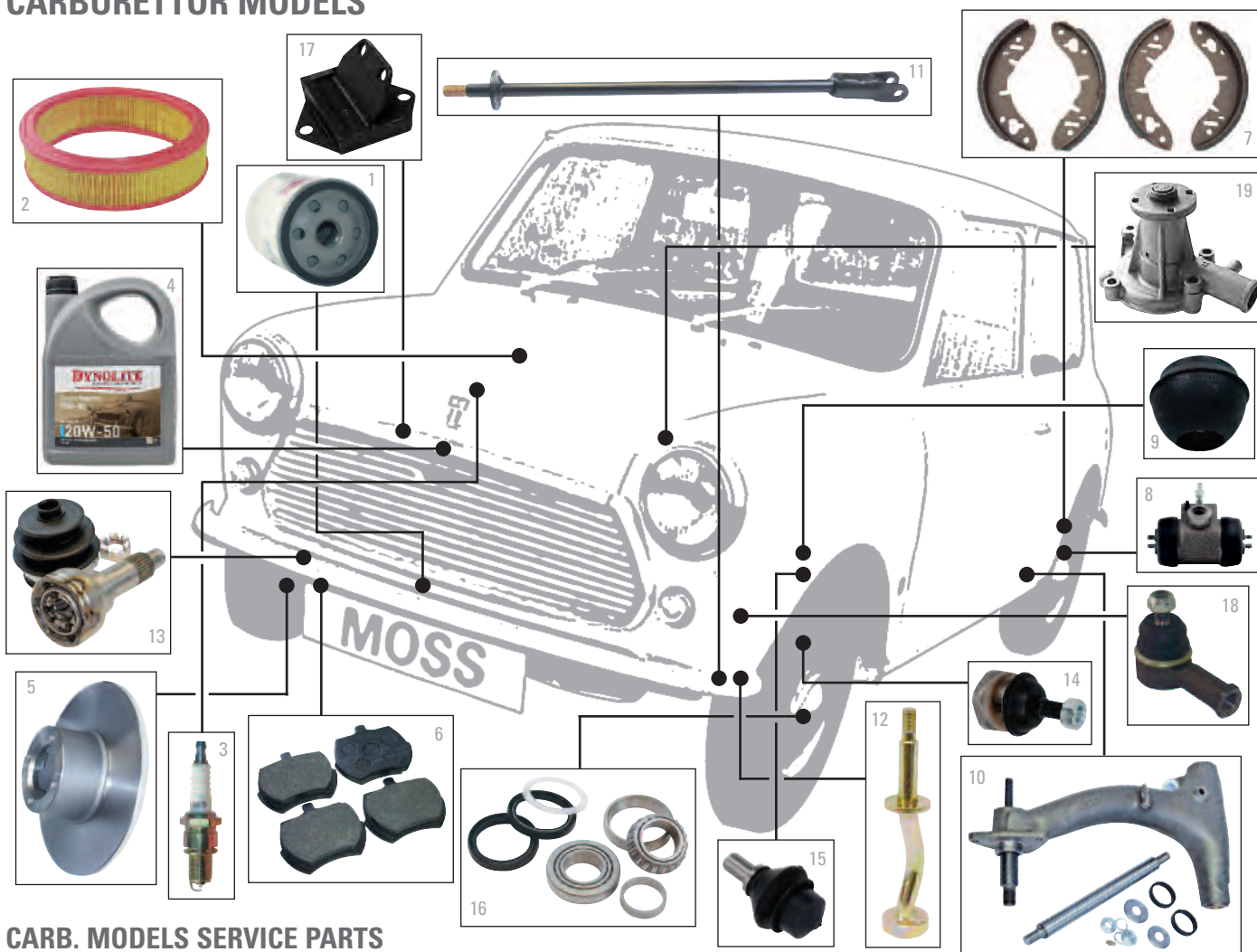

CARB. MODELS SERVICE PARTS

Old school carb Minis are still very popular with Mini owners. By far the easiest model to service there really are no excuses for neglect. Go on give it a treat.

- 1 Oil filter cartridge type (manual models)GFE166£2.76
- Oil filter paper element type (auto models) ..GFE104£4.24
- Air filter element (998cc)GFE1008£6.50
- 2 Air filter element (1275cc)GFE1096£4.30
- 3 Spark plug (each) (1275cc)BPR6ES£5.15
- Fan belt (1985 on)GCB10825£5.20
- Contact set 45D distributorGCS118£3.76
- Condenser 45D & 59D distributorGSC2109£2.95
- 4 Dynolite Classic 20W/50GGL812150 . . £29.80
- Breather hose stepped12A1735£6.85

CARB. MODELS BRAKE PARTS (DISC & DRUM)

Keep your brakes in tip top condition. Replace anything you think is worn with new! Better safe than sorry and at these prices why wouldn't you?

- 5 Front disc 8.4" diameter 12" wheelsGBD90806 . . £11.40
- 6 Front disc pad set 8.4" disc (4 piece)GBP281£12.90
- Rear brake drum with spacerGDB106Z£17.00
- Front or rear brake drum no spacerGDB105Z£12.00
- 7 Rear brake shoe set (4 piece)GBS834AF . . . £13.70
- Front brake shoe set (4 piece)GBS733AF . . . £13.00
- 8 Rear wheel cylinderGWC1102Z . . . £7.00

CARB. MODELS SUSPENSION & RUNNING GEAR

We have all seen a Mini going down the road nose diving on the front driver's side! Or followed one that looks like it's driving side ways, you might even have

the problem yourself? Worn radius arm...a collapsed suspension cone or even just a worn knuckle joint. Give us a call we can help with the parts you need.

- 9 Suspension cone metric genuine RoverFAM3968£56.00
- 10 Radius arm complete RH OE newNAM7162N . .£222.00
- Radius arm complete LH OE newNAM7163N . .£222.00
- 11 Front tie bar (each)21A450£8.90
- 12 Fulcrum pin front lower arm2A4362Z£12.70
- 13 Outer CV joint (disc brake models)GCV1013£36.00
- Upper arm repair kit2A4325K£15.60
- 14 Swivel pin kits one side upper and lowerGSJ166£8.10
- 15 Knuckle joint inc. gaiter and cup (each)GSV1118£3.18
- 16 Taper front wheel bearing kit (each)GHK1140 . . . £25.20
- Taper rear wheel bearing kit (all models) (each) GHK1548 . . .£12.50

CARB. MODELS GENERAL PARTS

MOT fails or just annoying niggles, some of the common culprits can be found here.

- Engine mounts (all models except auto)21A1902£3.64
- 17 Front subframe rear mounting21A2599Z£3.58
- Engine steady bar bush (fitted in pairs)CRC5329£1.70
- 18 Track rod end (each)GSJ734Z£5.40
- Gaiter kit outer CV joint OE heavy dutyGSV1053£8.00
- 19 Water pump, with bypassGWP134£18.00
- Steering rack gaiter kit OE steel clipsGSV1153£6.00
- Rocker cover gasketGUG705009VC .£1.32
- Inlet & exhaust manifold gasketAJM601£2.05
- Thermostat standard 82°C (180°F)GTS104£3.80
- Oil seal rod changeAHU1672£1.70
- Oil seal diff. output shaftADU5738£1.10

SPI MODELS

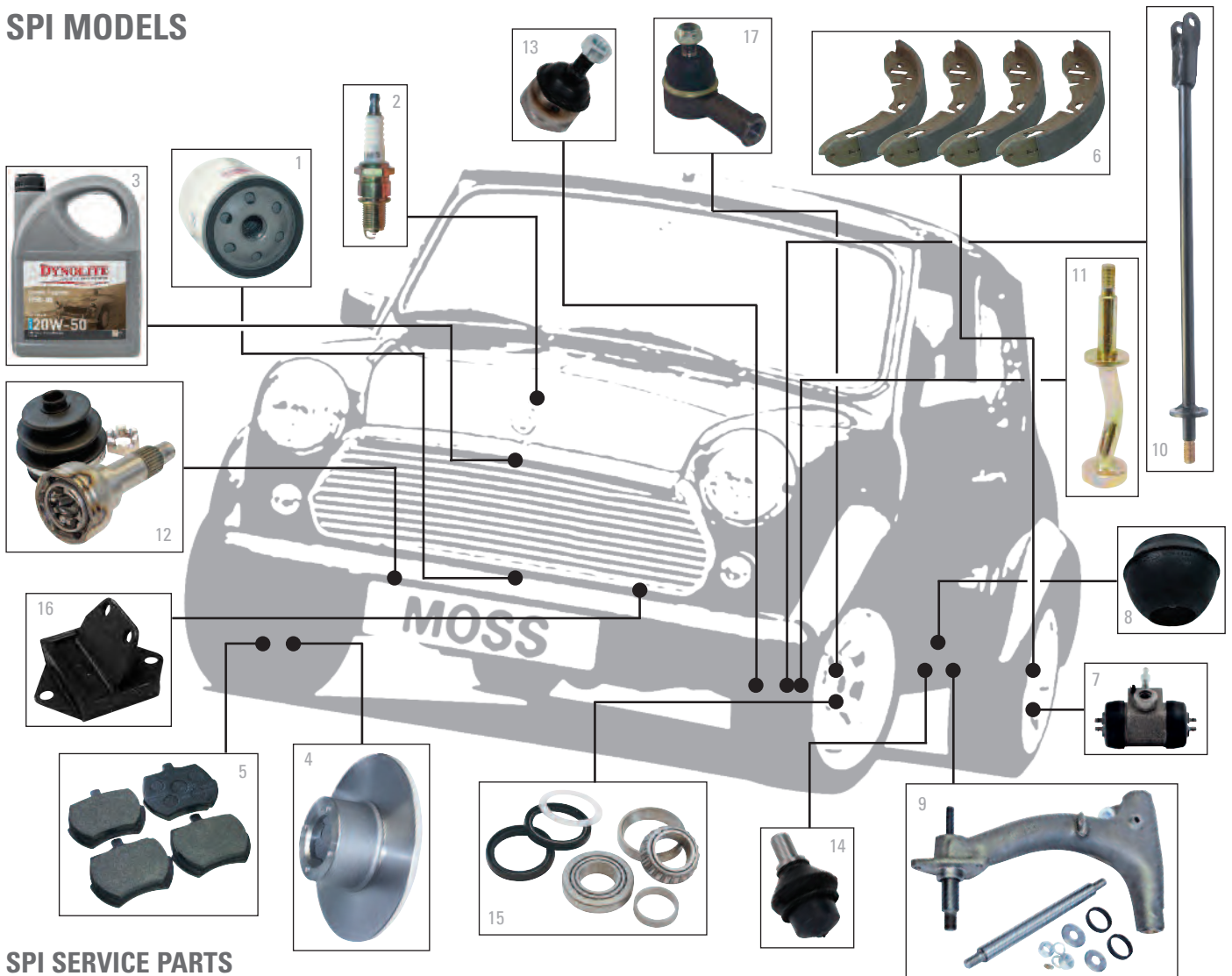

SPI SERVICE PARTS

Regular servicing is the best way to keep on top of your Mini. To ensure reliability as well as functionality use the best parts you can! Cheap oil and a dodgy filter might do more damage than you think.

- 1 Oil filter cartridge type (to 1996) GFE166 **£2.76**
Air filter element (to 1996) GFE1143 **£12.40**
Fuel filter 20mm outlet nut (to 1996) GFE7059 **£11.20**
- 2 Spark plug (to 1996) (each) BPR6ES **£5.15**
Fan belt (to 1996) GCB10825 **£5.20**
- 3 Dynolite Classic 20W/50 GGL812150 .. **£29.80**

SPI BRAKE PARTS

It's all well and good making your pride and joy go a little faster with the odd tuning part here and there, but will it stop? Quite often Mini brakes are totally neglected and in a sorry state, why not check them over and replace any worn components with new, it's not that expensive and could save a life!

- 4 Front disc 8.4" diameter GBD90806 ... **£11.40**
- 5 Front disc pads set (4 piece) GBP281 **£12.90**
Rear brake drum spaced GDB106Z **£17.00**
- 6 Rear brake shoe set (4 piece) GBS834AF ... **£13.70**
- 7 Rear wheel cylinder GWC1102Z ... **£7.00**

SPI SUSPENSION & RUNNING GEAR

Crabbing, sagging and banging are all common terms used to describe the Classic Mini and people are usually referring to the suspension! Don't panic if you have any of the above problems we are here to help and have the parts and the solutions for you.

- 8 Suspension cone metric genuine Rover FAM3968 **£56.00**
- 9 Radius arm complete RH OE new NAM7162N . **£222.00**
Radius arm complete LH OE new NAM7163N . **£222.00**
- 10 Front tie bar (each) 21A450 **£8.90**
- 11 Fulcrum pin front lower arm 2A4362Z **£12.70**
- 12 Outer CV joint GCV1013 **£36.00**
Upper arm repair kit 2A4325K **£15.60**
- 13 Swivel pin kits one side upper and lower ... GSJ166 **£8.10**
- 14 Knuckle joint inc: gaiter and cup (each) ... GSV1118 **£3.18**
- 15 Taper front wheel bearing kit (each) GHK1140 **£25.20**
Taper rear wheel bearing kit (each) GHK1548 **£12.50**

SPI GENERAL PARTS

We all know Mini has it's problem areas, we usually find out what they are come MOT time! Here are some common parts that might need to be replaced.

- Engine mounts 21A1902 **£3.64**
- 16 Front subframe rear mounting 21A2599Z **£3.58**
Engine steady bar bush (fitted in pairs) CRC5329 **£1.70**
- 17 Track rod end (each) GSJ734Z **£5.40**
Gaiter kit outer CV joint OE heavy duty ... GSV1053 **£8.00**
Water pump (no bypass) GWP187 **£18.70**
Steering rack gaiter kit OE steel clips GSV1153 **£6.00**
Rocker cover gasket GUG705009VC . **£1.32**
Inlet & exhaust manifold gasket AJM601 **£2.05**
Thermostat standard 88°C (190°F) GTS106 **£4.43**
Oil seal rod change AHU1672 **£1.70**
Oil seal differential output shaft ADU5738 **£1.10**

MPI MODELS

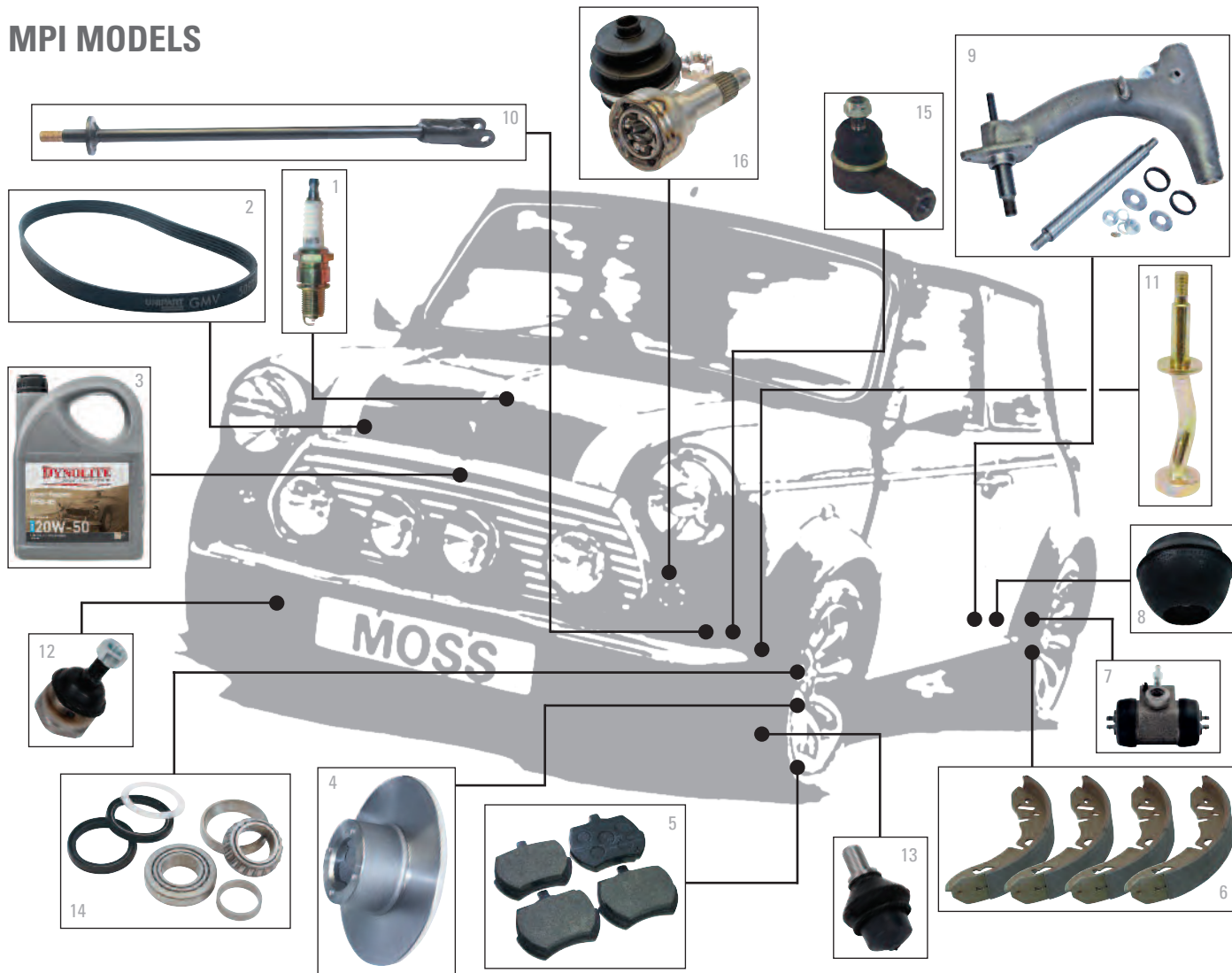

MPI SERVICE PARTS

Keeping your Mini's engine in top condition has to come high on the agenda, regular servicing with good quality parts is easy and doesn't need to cost a fortune! Prevention is always the better option.

- Oil filter cartridge type (1996 on) LPW100180 . . . £3.68
- Air filter element (1996 on) GFE1143 £12.40
- Fuel filter 20mm outlet nut (to 169573 chassis) . GFE7059 £11.20
- Fuel filter (169574 chassis on) WJN101190 . . . £10.40
- 1 Spark plugs (each) (1996 on) BPR6ES £5.15
- 2 Fan belt multi groove (1996 on) GMB50920 . . . £10.80
- 3 Dynolite Classic 20W/50 GGL812150 . . . £29.80

MPI BRAKE PARTS

One of the most important components on any car has to be the brakes! The Mini is no exception to this. It's so important to check the condition of your brakes on a regular basis! If in doubt... replace with new parts.

- 4 Front disc 8.4" diameter GBD90806 . . . £11.40
- 5 Front disc pads set (4 piece) GBP281 £12.90
- Rear brake drum spaced GDB106Z £17.00
- 6 Rear brake shoe set (4 piece) GBS834AF . . . £13.70
- 7 Rear wheel cylinder GWC1102Z . . . £7.00

MPI SUSPENSION PARTS & RUNNING GEAR

Knocks and bangs are quite common on Mini, usually caused by part of the suspension being badly worn. The MPI model does seem to suffer a little

more mainly due to the larger and wider wheels fitted. The common failure parts are listed below.

- 8 Suspension cone metric genuine Rover FAM3968 . . . £56.00
- 9 Radius arm complete RH OE new NAM7162N . £222.00
- Radius arm complete LH OE new NAM7163N . £222.00
- 10 Front tie bar (each) 21A450 £8.90
- 11 Fulcrum pin front lower arm 2A4362Z £12.70
- Upper arm repair kit 2A4325K £15.60
- 12 Swivel pin kits one side upper and lower GSJ166 £8.10
- 13 Knuckle joint inc: gaiter & cup (each) GSV1118 £3.18
- 14 Taper front wheel bearing kit (each) GHK1140 . . . £25.20

MPI GENERAL PARTS

Here are some of the parts we get asked for on a regular basis. Helping you to keep your Mini alive and in the best possible shape is why we are here and we are constantly checking not only our product but also our prices!

- Engine mounts 21A1902 £3.64
- Engine steady bar bush (fitted in pairs) CRC5329 £1.70
- 15 Track rod end (each) GSJ734Z £5.40
- 16 Outer CV joint GCV1013 £36.00
- Gaiter kit outer CV joint OE heavy duty GSV1053 £8.00
- Water pump, no bypass GWP187 £18.70
- Steering rack gaiter kit OE steel clips GSV1153 £6.00
- Rocker cover gasket GUG705009VC . £1.32
- Inlet & exhaust manifold gasket LKJ100580EVA . £7.50



Classic Mini **Restoration Parts**



Ordering Information

Notification of prices

Due to the volatility of world markets and currency fluctuations the prices in this catalogue are subject to change. Moss make every attempt to keep prices competitive and stable, however in common with all other suppliers in our industry, we reserve the right to alter these prices without prior notice.

For the latest prices, please visit our website www.moss-europe.co.uk. All prices are per unit (unless otherwise stated) and include (UK) VAT at 20% (where applicable) and are correct at the time of going to print. Postage and packaging is not included. E&COE. Where the price is replaced with NCA this part is Not Currently Available. Please visit our website (moss-europe.co.uk) or call our sales staff for the latest availability information or to enquire if we can offer an alternative part.

Product supersessions

Moss Europe's policy is to detail the most up to date part information in our catalogues. Where possible parts are kept to original specification. However, in some instances we have to supersede to the most viable alternative product to maintain supply and keep cars on the road. Every effort is made to ensure high quality products.

UK ordering

We accept orders by mail, telephone, e-mail, fax and on-line at www.moss-europe.co.uk. If you have the opportunity, we invite you to visit one of our branches. Remember, supplying details of your car, (i.e. engine, commission or Vehicle Identification Number (VIN) LHD or RHD, year of manufacture and any modifications) saves time and helps us to help you. Please inform us of your customer number, as this will speed up the processing of your order.

Overseas ordering

We accept orders by mail, telephone, e-mail, fax and on-line at www.moss-europe.co.uk. If you visit the U.K. please come and visit one of our branches. When ordering, please ensure that you enclose full details of your name, address and customer number, plus details of your car (i.e. engine, commission or Vehicle Identification Number (VIN) LHD or RHD, year of manufacture and any modifications).

Please note: Overseas orders are often subject to local import duties, taxes and Customs clearance, which will need to be paid for at the point of entry. These charges are NOT included in the price of the goods or delivery prices. All relevant Customs forms and documentation needed to ensure the order arrives with the minimum of delay, will be included with your shipment. If you have any special requirements, please contact us to discuss them. Delivery charges are dependent upon the size and weight of the shipment. If a quotation is required prior to placing an order, please contact the export department at your chosen branch and they will be pleased to supply a full quotation.

Parts back-order system

A back-order system is used when a part is not in stock at the time of ordering. If the item is expected to become available within 6 months, then it will be put on back-order, unless the customer instructs us otherwise. When we have the parts in stock, the back-order will be processed automatically and the item will be dispatched to the customer. If the particular part becomes No Longer Available (NLA) or does not become available within 6 months the back-order will be cancelled. If you are unsure when you placed a back-order contact your local branch.

Dispatch & delivery methods

Orders for delivery in the UK may be dispatched by regular post for small/lightweight items, larger items may be dispatched via a courier. Please call us for the best delivery option for your order and the latest delivery prices. For delivery outside the UK we offer the following services.

- **Economy delivery (by road):** 2 to 5 days (approximately).
- **Express delivery (by air):** 1 to 2 days (Guaranteed) - next day service to most countries.
- **For small and low value orders we also use airmail.**

For these services, please ask for prices and the best delivery option when you place your order. Most deliveries (except airmail) are 'trackable', (inc: e-mail updates and internet access for selected carriers). Please remember, all carriage charges are dependent on weight band, volume, destination and delivery time. If a quotation is required prior to placing your order, please contact a member of the sales department. Alternatively, you can arrange your own delivery and dispatch.

Windscreens delivery information

We always suggest that windscreens should be collected from one of our branches to ensure you are able to transport your glass with the utmost of care. However, we understand that this is not always possible.

To minimise the possibility of damage to the windscreen in the shipping process, it is now Moss Europe's policy to ship windscreens packed in a specially designed heavy duty 'Tri-Wall' cardboard box. The price of this box is £35.00 (Ex VAT), non-refundable and is not included in the price of the product. The crate's dimensions will also increase shipping costs, particularly in EU countries. The crate dimensions are 150cm x 33cm x 74cm. The maximum volumetric weight is 92kgs. For more information please contact your nearest Moss branch.

Hazardous goods delivery information

At the time of going to print, Moss Europe Ltd conforms to international shipping regulations regarding packaging and transportation of Hazardous Goods by road and sea freight (only). Due to these international shipping regulations and licencing rules all goods deemed as Hazardous are currently available for shipping to the UK and Europe only. If you place an order containing Hazardous goods and your shipping address is not in the UK or Europe, we will not be able to ship this item to you. Please contact your local branch or visit our website moss-europe.co.uk for the latest delivery information of Hazardous goods.

Quotations & payment methods

We will be pleased to provide a full parts quotation detailing price, availability and relevant shipping costs. Payment may be made by cash, personal cheque (to the card guarantee limit), Certified Bank Draft, Sterling Travellers Cheques and credit or debit card including: Mastercard, Visa, Delta. If you intend to make payment by Cheque or Bankers Draft when

using our fast mail-order parts service, please confirm parts availability and carriage charges. We can accept payments using PayPal for website, email and phone orders.

Value added tax (VAT)

Value Added Tax (VAT) at the current rate will be levied on all orders being dispatched to all countries within the European Community. EU countries may be charged at their local VAT rate, please contact us or see website for details. VAT is not charged on goods dispatched to countries outside of the EU. However, such orders are often subject to local import duty, taxes and Customs clearance, which MUST be paid by you at the port of entry. Such charges are not included in the cost of the goods or delivery prices.

Exchange units

We are able to offer a full rebuild service on numerous major components in our product range. We offer this service as an alternative to direct replacement parts, or when a brand new item is no longer available. However, the continuity of this exchange scheme needs the understanding and co-operation of our customers in relation to several important points: It is important to remember that "rebuild" does not mean "brand new". Rebuilding a unit involves stripping, cleaning, inspecting and re-assembling the unit. During this process, parts showing signs of wear will either be completely replaced or suitably renovated. However, it is not always feasible for major sub-components to be replaced with brand new ones, for example, an exchange engine will not have a new block. Due to the nature of certain product lines, some items can only be offered on a "one for one" exchange basis. This effectively means that you must offer us a viable unit before we can release a fully rebuilt item from our stock. In some instances we can only carry out reconditioning of your own unit. Our staff will inform you if this is the case.

All exchange units are subject to a surcharge. This surcharge serves two purposes; firstly, it acts as an incentive for you to return your old unit, and secondly it provides us with financial cover if your returned unit proves unsuitable for exchange purposes.

Whether or not your returned unit is suitable for exchange purposes cannot be ascertained until it is made available to us for inspection. As a general rule, suitable for exchange basically excludes any items that are beyond reasonable repair (e.g. crankcases pierced by a connecting rod) or units irrevocably damaged. We are also unable to accept units unless they are returned in whole, complete form (i.e. differential units which are returned partly stripped with no bearings and all the shims missing are not generally accepted), nor do we accept a "box of bits".

Surcharges will only be refunded once our core department has passed the item as serviceable. Under no circumstances can any exchange unit be shipped overseas until we receive your original unit. We have predetermined prices for our exchange units based on our experience of repair costs for a gearbox, axle or engine. Occasionally, however, the damage to the unit is so great that we will contact you before beginning work on your unit to advise you of any additional cost that may be incurred during the rebuild of the unit. We can return the unit (at your cost) if this proves unacceptable.

'Old unit' returns

Exchange items including reconditioned engines are subject to a surcharge that is refunded when a rebuildable unit (core) is returned. When you receive the rebuilt unit, attached to it will be a Core Return Authorisation Tag. This tag must be removed from the rebuilt unit and attached to the returned core in order to receive credit. Cores must be returned within 90 days of purchase in the original box, carton or engine cradle supplied with the rebuilt unit. Cores must be shipped clean and empty of fluids. Cores must be complete, assembled and rebuildable to receive credit or refund. You must pay all shipping charges for the return of the core and these charges are not refundable.

Warranty

All parts are warranted against defects in materials and workmanship for a period of twelve (12) months from the date of purchase. The warranty does not cover failure resulting from incorrect installation or misuse; failure during any competition, motorsports or track events; failure of any, or caused by any, related component. The warranty does not cover labour charges, nor will a warranty settlement be greater than the cost of the original component. Should you need to make a warranty claim, please contact us immediately at the branch of purchase. We will then advise you as to the best course of action. With all warranty claims a copy of the original purchase invoice must be produced.

Warranty returns

Parts that fail in use may be returned for 12 months from the date of purchase. Returns must be accompanied by the original invoice - no warranty claims will be paid without a copy of the original invoice. Return freight will be reimbursed. Electrical parts returned for warranty will be tested and if found functional, no return credit will be given and the part will be returned. Reimbursement is made by the original payment method. Complete the return form included in each order, pack the items securely and use the shipping return label supplied.

Non-warranty returns

All uninstalled parts, in their original packaging may be returned within 90 days for any reason. A copy of the original invoice or the picking label (which is generally attached to the original packaging) must accompany the return. Return freight is paid by the customer. If the return is due to our error, the return freight will be reimbursed. Parts returned outside of this policy or in non-resalable condition may not be accepted or may be assessed a 15% handling fee. Reimbursement is made by the original payment method. Complete the return form included in each order, pack the items securely and use the shipping return label supplied.

Customer service

We value your custom and wish to ensure that you receive the very best service. Every effort will be made to provide you with Quality Parts and Expertise in a relaxed, helpful and friendly manner. Should you consider the service you receive from us to be unsatisfactory, or you have any problems with the part(s) purchased, please advise a member of the sales team at the originating branch. If the matter is not resolved to your satisfaction, please contact our Customer Services Department and we will do our very best to resolve the issue, either email: customerservices@moss-europe.co.uk or write to: Customer Services, Moss Europe Ltd Unit 16, Hampton Business Park, Bolney Way, Feltham TW13 6DB England.

British Motor Heritage

Moss Europe Ltd is a British Motor Heritage approved specialist. Our agreement with British Motor Heritage allows us the use of marque logos and some of the artwork contained within this catalogue.



A		
A post	Page 22	
A series identification	Page 09-11	
Accelerator cable	Page 40	
Accelerator pedal	Page 40	
Aerial	Page 85	
Air duct	Page 62	
Air filter	Page 43	
Alternator	Page 59	
Alternator pulley	Page 59	
Anti run on valve	Page 23	
B		
Badges & decals	Page 84	
Battery	Page 61	
Battery box	Page 74	
Battery cables	Page 61	
Bodyshell	Page 71	
Body repair panels	Page 72-76	
Bonnet	Page 72-75-77	
Bonnet release kit	Page 77	
Boot floor	Page 74	
Boot lid	Page 73	
Brake back plates	Page 51-53	
Brake caliper	Page 52	
Brake disc	Page 52	
Brake drums	Page 51-53	
Brake hoses	Page 56-57	
Brake master cylinder	Page 54-55	
Brake pipe conversion kit	Page 56-57	
Brake pad set	Page 52	
Brake pipes	Page 56-57	
Brake servo	Page 55	
Brake shoes	Page 51-53	
Brake/clutch fluid	Page 57	
Bump stops	Page 46	
Bumper	Page 83	
Bypass hose	Page 38	
C		
Cam follower	Page 14-17	
Camshaft	Page 14-17	
Car cover	Page 85	
Carburettor	Page 39-40	
Carpet set	Page 85	
Centre binnacle kit	Page 66	
Chassis plates	Page 84	
Choke cable	Page 40	
Clutch assembly	Page 24-25	
Clutch hose	Page 26-27	
Clutch master cylinder	Page 26-27	
Clutch fluid	Page 27	
Clutch slave cylinder	Page 26-27	
Coil	Page 60	
Con rod	Page 14-17	
Condenser	Page 60	
Contact set	Page 60	
Cooling fan	Page 38	
Crank pulley	Page 14-17	
Crankshaft	Page 14-17	
Crossmember	Page 74	
Crown wheel	Page 31	
CV joint	Page 49	
Cylinder head	Page 18-19	
Cylinder head gasket	Page 18-19	
D		
Damp shield kit	Page 60	
Dash panel kits	Page 85	
Dash pot cover	Accessories	
Dash rail	Page 72	
Decals	Page 84	
Differential unit	Page 31	
Dipstick	Page 22	
Distributor	Page 60	
Door	Page 73-80	
Door glass	Page 80	
Door hinges	Page 78-80	
Door locks	Page 78-80	
Door seals	Page 78-80	
Drive flange	Page 49	
Drive shaft	Page 49	
Drive shaft gaiters	Page 49	
Drop gears	Page 30	
Duplex gear kit	Page 14-17	
E		
Electric cooling fan	Page 38	
Engines	Page 13	
Engine gasket set	Page 13	
Engine mountings	Page 20	
Engine stabilisers	Page 20-21	
Exhaust system	Page 34-35	
Exhaust manifold	Page 34-35	
Exhaust valves	Page 18-19	
Expansion tanks	Page 36-37	
F		
Fan belt	Page 38	
Flasher unit	Page 61	
Floor panel	Page 74-75	
Flywheel	Page 24	
Fog lamps	Page 69	
Front panel	Page 72-75	
Fuel hose	Page 42	
Fuel injection	Page 41	
Fuel pump	Page 42	
Fuel sender unit	Page 42	
Fuel tank	Page 42	
Fuse box cover	Page 61	
Fuses	Page 61	
G		
Gauge face kit	Page 66	
Gauge, ammeter	Page 66	
Gauge, clock	Page 66	
Gauge, dual	Page 66	
Gauge, fuel	Page 66	
Gauge, oil pressure	Page 66	
Gauge, oil temperature	Page 66	
Gauge, speedometer	Page 66	
Gauge, tachometer	Page 66	
Gauge, voltmeter	Page 66	
Gauge, water temperature	Page 66	
Gear lever	Page 29	
Gearbox	Page 28-33	
Gears	Page 30-31	
General hardware	Page 86-88	
Glazing	Page 81	
Grille, front	Page 82	
H		
Handbrake cable	Page 58	
Handle, bootlid	Page 77	
Handle, door	Page 78-80	
Handle, window winder	Page 79	
Head gasket set	Page 18	
Headlamp	Page 68	
Headlining	Page 85	
Heater unit	Page 62-63	
Heater cable	Page 62	
Heater hoses	Page 62-63	
Heater matrix	Page 62	
Horn	Page 61	
HT lead set	Page 60	
Hub	Page 46-48	
Hub bearing kit	Page 48-49	
Hub cap	Page 84	
I		
Idle gear	Page 30-31	
Indicator	Page 68-69	
Inlet manifold	Page 34-35	
Inlet valves	Page 18-19	
Inner sills	Page 74	
Interior lamp	Page 70	
J		
Jet assembly	Page 39	
K		
Knuckle joint	Page 46-48	
L		
Layshaft	Page 30-31	
M		
Main bearings	Page 14-17	
Mat sets	Accessories	
Mirrors	Page 84	
Mudflaps	Page 84	
N		
Number plate lamp	Page 70	
O		
Oil breathers	Page 22-23	
Oil controls	Page 22	
Oil filler cap	Page 19	
Oil filters	Page 22	
Oil hoses	Page 22-23	
Oil pipes	Page 22	
Oil pump	Page 22	
Ordering options and procedures	Page 01	
Outer sills	Page 74	
Over riders	Page 83	
P		
Pedal, accelerator	Page 40	
Piston set	Page 14-17	
Primary gears	Page 14-17	
Push rods	Page 14-17	
Q		
Quarter light	Page 81	
Quarter panel	Page 72-73	
R		
Radiator	Page 36-37	
Radiator hoses	Page 36-37	
Radius arm	Page 48	
Rear lamp	Page 69	
Rear screen	Page 81	
Ring gear	Page 24	
Rocker cover	Page 18-19	
Rocker set	Page 18-19	
Roof panel	Page 72	
Rotor arm	Page 60	
S		
Seat belts	Accessories	
Shock Absorbers - front	Page 46-47	
Shock Absorbers - rear	Page 48	
Side repeater lamp	Page 68	
Sound insulation	Page 85	
Spark plug	Page 60	
Speedometer drive cable	Page 66	
Starter motor	Page 59	
Starter solenoid	Page 59	
Steering arm	Page 46-47	
Steering column	Page 50	
Steering lock	Page 50	
Steering rack	Page 50	
Steering wheels	Accessories	
Stub axle	Page 48	
Stub stack	Page 43	
Subframes	Page 44-45	
Subframe mounting	Page 44-45	
Sun visors	Page 85	
Suspension, front	Page 46-48	
Suspension cones	Page 46-48	
Switches, column	Page 65	
Switches, dash	Page 65	
Switches, miscellaneous	Page 65	
Swivel pin kits	Page 46-47	
T		
Tail gate	Page 73	
Technical advice	Page 04-09	
Temperature transmitter	Page 65	
Thermostat	Page 36-37	
Thermostat housing	Page 36-37	
Throttle body	Page 41	
Thrust washer set	Page 15	
Tie bars	Page 46-47	
Timing chain	Page 14-17	
Tool rolls	Page 85	
Track rod ends	Page 50	
Trim panel kits	Page 85	
Trunnion rear subframe	Page 45	
V		
Vacuum unit	Page 60	
Valance, rear	Page 73	
Valve guides	Page 18-19	
Valve springs	Page 18-19	
Van panels	Page 73	
Voltage stabiliser	Page 66	
W		
Washer bottle	Page 64	
Washer jet	Page 64	
Washer pump	Page 64	
Water pump	Page 38	
Water pump pulley	Page 38	
Water heater valve	Page 63	
Weather strip	Page 78-81	
Wheel arch extensions	Page 83	
Wheel cylinders	Page 51-53	
Window regulator	Page 80	
Window catches	Page 79	
Windscreen	Page 81	
Wing, front	Page 72	
Wing, rear	Page 72	
Wiper arm	Page 64	
Wiper blade	Page 64	
Wiper bush kit	Page 64	
Wiper motor	Page 64	
Wiper wheel box	Page 64	
Wiring loom	Page 67	
Wood body kit	Page 73	



Engine Preparation

This is a general guide to correct procedures and will apply, wholly or partly to all types of engine rebuild. However, before the engine rebuild can begin the engine needs to be stripped down, cleaned and examined, a procedure which many undertake with undue haste. During the strip down the following should be observed:

1. Wait for the engine to cool properly before removing the cylinder head - this applies especially to aluminium type heads. The consequence of not waiting can result in a warped head.
2. Mark the location (and, where applicable, orientation) of all major components especially valves, tappets, camshafts, pistons and rods, shell bearings by placing in clearly marked containers or racks.
3. Before removing bearing caps (e.g. camshaft, con rod, main bearing), make sure they are clearly marked for position and orientation.

Note: They must go back in the same position or on the same con rod and the right way round.

Once stripped all parts should be thoroughly cleaned and inspected with specific attention to any areas of bad wear or damage e.g:

1. Blown head gasket/burnt out valves - cylinder heads should always be thoroughly examined for cracks or distortion. Simply fitting a new gasket or valve is not the answer.
2. Damaged piston/rings - always check the cylinders for wear and damage. If the pistons need replacing, a rebore or cylinder hone is almost certainly needed as well. Damage to bores often appearing at the limits of the piston ring travel may well be what dictates the need for a rebore or at least a professional hone.
3. Badly worn crankshaft shell bearings - if the crankshaft is badly scored it must be reground to the next undersize. However, just as important are the con rod and main bearing housings that the shell bearings fit into. These are often overlooked and any wear or distortion in these areas will cause premature engine failure.

Cleaning should include removal of all oil gallery plugs to enable thorough cleansing with brushes. Many parts can be re-used during the rebuild but the following items should always be replaced:

1. All Gaskets And Seals.
2. Shell Bearings.
3. Timing Belts Or Chains.
4. Timing Belt/Chain Tensioners.
5. Piston Rings.
6. Oil Pump Drives.
7. All Major Fastenings Including Cylinder Head, Con Rod And Flywheel Bolts.

Engine Rebuild

The following highlight important procedures during the re-assembly of a modified engine:

1. **THOROUGHLY** clean and check **ALL** parts - your engine's worst enemy is dirt, even new parts may need cleaning. This includes the head and block and all oil galleries.
2. **ALWAYS** fit new high quality gaskets and seals, ensuring all shafts and mating surfaces are free from burrs and defects. Use correct sealants or lubricants where necessary.
3. **LIBERALLY** oil all internal parts during assembly. Use the special assembly lube or gear oil on cam lobes and tappet faces.

4. **ALWAYS** replace cam followers when fitting a new camshaft.
5. **ALWAYS** replace con rod, flywheel and cylinder head studs and bolts. All other fastenings should be checked for wear or damage and replaced as necessary. For high specification engines, race quality fastenings are available for most applications.
6. **CLEAN** all threads and fastenings prior to fitment and use a good quality torque wrench on all critical components. Apply an anti-seize lubricant to all cylinder head fixings.
7. If you are fitting high lift cams, special pistons, or large valve heads, always carry out a dummy engine build and check valve to piston/block clearances. Machine piston crowns/valve pockets or block face as necessary.
8. **INCORRECT** cam timing can severely reduce the power output so don't overlook this area during assembly. Use adjustable cam pulleys or sprockets where available.
9. **CHOOSE** compatible parts for your specific conversion. A full race specification head will be next to useless if fitted to a mild road stage engine. Modified camshafts and cylinder heads in particular should be chosen with care.



10. **UNLESS** you know what you are doing, avoid over-lightening components. Reducing the weight of some parts may also reduce their strength to a critical level.
11. **ALWAYS** have the engine assembly balanced - it will make a lot of difference to the smoothness and help maintain optimum reliability.
12. **DON'T** forget the clutch - depending on the power increase, a suitable heavy duty or competition clutch assembly will be required.
13. **OIL** And **FILTER** - the importance of using the correct specification of oil cannot be overstated. Please contact your local branch for advice.

Most engine modifications should be followed up with a professional engine tune. Apart from emissions, the correct ignition timing and fuelling is paramount if you want the best return for all the expense and effort you have put in. Get these important settings wrong and you may lose more than just a bit of power. Over-fuelling (rich mixture) can result in excessive piston, ring and bore wear. Under fuelling (weak mixture) or retarded ignition can cause overheating problems. An ignition set with too much advance is likely to induce detonation or 'pinking' which, if left uncorrected, can shatter pistons and place excessive loads on the bottom end. You have been warned!

Lastly, please check that your suspension and braking systems are adequate for the power increase you have achieved. A full range of optional equipment can be found further in the Moss Europe catalogue.

Camshafts

Camshaft Fitting Instructions

The installation and first few moments of running are critical factors in the life of the camshaft. Failure to install the camshaft correctly will have a drastic effect on the life of the camshaft and in the worst cases can result in immediate failure. The following instructions must be adhered to in order to obtain maximum performance from the engine and to ensure a long and trouble free life from both camshaft and associated components. These instructions are also provided in addition to the original manufacturer's installation procedure.

Where a camshaft is being replaced due to excessive wear, it would be highly recommended to strip the engine and fully clean the internals. Metal particles present in the sump, oil pump, bearings and oil galleries will soon play havoc with the new cam. It would also be wise to check the oil feed system. Low oil pressure due to a worn pump, blocked pick-up pipe or blocked oil galleries will quickly wear the new cam to the same state as the one being replaced. In other words, before replacing a failed camshaft, make sure you find out the reasons for the failure and correct it!



Before fitting the camshaft, check that it is identical in every aspect (with the exception of the lobe profiles) to the one being replaced. Special attention should be given to the oil feed positions and journal diameters as variations may occur during the manufacture of the engine. Also check that any gallery bungs present on the old cam are also in place on the new cam. Do not remove the black phosphate coating from the new cam lobes. Liberally coat both the camshaft and cam followers with a proprietary cam lube or engine assembly compound. We recommend and use a colloidal graphite paste. Failure to do this can cause scuffing between the surfaces of the cam and followers, which will result in premature wear. Ensure that followers are free to rotate in their bores where applicable. It is essential that new followers are always fitted, regardless of the condition or limited use of the old followers. Failure to do so may cause premature components failure and consequently will invalidate any warranty claim.

Upon installation, the valve springs must be checked to ensure that:

1. The fitted length (installed height) of the valve springs match the figure provided by the manufacturer. If too small, then the valve seat areas in the head will require machining. If too large, shims can be added to the spring seat. Due to varying manufacturing tolerances of cylinder heads, all springs should be checked and measured for clearance.
2. Coil binding does not exist at full valve lift. This is the condition where the spring is fully compressed. As a guide, the spring should be able to compress a further 0.060" (1.5mm) before the coil bound condition is reached. This can be checked by inserting

feeler gauges between each coil of the spring and adding the results together to get a total clearance figure. Due to varying manufacturing tolerances of cylinder heads, all springs should be checked and measured for clearance.

Check the clearance between the bottom face of each retainer and the top of the guide or stem seal at full lift. This should be a minimum of 0.080" (2mm). If this clearance cannot be achieved, the top of the guides must be machined. When double valve springs are being installed in place of singles, ensure the inner spring is correctly located and the correct retainers and platforms are used where applicable. When modifying engines that utilise finger followers, it is imperative that you ensure the followers remain in the original attitude relative to the cylinder head. Failure to do so will alter the rocker geometry, increasing or decreasing valve lift and can result in failure of both cam and followers or excessive valve stem/guide wear. For OHV engines, attention should be paid to rocker arm geometry for the same reasons.



Camshaft Timing

Determining True Crank TDC Position - Head Off Block

Although the crank pulley will have a mark to show TDC position, this point may not be accurate due to manufacturing tolerances. It is always recommended to calculate the actual position of TDC rather than rely on the mark on the crank pulley. Fit the timing disc to the front of the crankshaft. A pointer for the timing disc can be made from a piece of bent wire secured under a suitable front cover bolt. Position a dial gauge to measure the travel of No 1 piston.

Turn the crank until the piston is at its maximum height and zero the gauge. You will find that there is a dwell period of approx. 10 degrees where the piston is at its maximum height. True TDC position is at the centre of this dwell period. To accurately measure the position of TDC, rotate the crankshaft and stop at a figure just before TDC, for example 0.020" on the dial gauge. Record the figure on the timing disc from the pointer. Now rotate the crankshaft and stop at the same figure (0.020") after TDC. Record the figure on the timing disc again. True TDC is positioned in the middle of these two figures. The TDC position can be calculated by adding the two figures together and dividing by two. Adjust the timing disc so that it reads zero on the pointer at true TDC.

Determining True Crank TDC Position - Head On Block

If the head has not been removed when changing the cam, it is still possible to measure the true TDC position. The procedure is the same as above but the movement of the piston is recorded by using an extension resting on the piston crown (such as a socket extension or push rod). Access to the piston crown is made through the spark plug hole.

Formula

Engine Capacity/Displacement

Information required: 1. Cylinder bore, 2. Crankshaft stroke, 3. Number of cylinders.

Calculation: $0.7854 \times \text{bore} \times \text{bore} \times \text{stroke} \times \text{number of cylinders}$.

Example: Bore = 73.5mm (7.35cm), Stroke = 81.3mm (8.13cm), cylinders.

Solution: $0.7854 \times 7.35 \times 7.35 \times 8.13 \times 4 = 1379.79\text{cc}$.

In the above example we have used centimetres to calculate capacity in cubic centimetres. To find the displacement in cubic inches simply substitute measurements in inches: 7.35cm = 2.893" and 8.13cm = 3.200" giving $0.7854 \times 2.893 \times 2.893 \times 3.200 \times 4 = 84.13 \text{ cu.in.}$

To quickly convert from cc's to cu.ins. divide by 16.387 and from cu.in. to cc. Multiply by 16.387.

Crankshaft Stroke

Information required: 1. Bore size, 2. Engine capacity, 3. Number of cylinders.

Calculation: Divide engine capacity by: $(0.7854 \times \text{bore} \times \text{bore} \times \text{no. of cylinders})$.

Example: 1380cc 4 cylinder engine with an 73.5mm bore size.

Solution: $1380 \div (0.7854 \times 7.35 \times 7.35 \times 4) = 169.717086$, $1380 \div 169.717086 = 8.13\text{cm}$.

Compression Ratio

Information required: 1. Capacity of ONE cylinder, 2. Compressed volume.

Cylinder capacity is the total engine displacement divided by the number of cylinders. E.g: 4 cylinder 1000cc engine = 250cc per cylinder.

Compressed volume is the area above the piston crown when the piston is at its highest point or top dead centre (TDC).

This area comprises:

1. The combustion chamber (usually in the cylinder head as shown, but can also be in the piston crown).
2. The head gasket thickness.
3. The area between the cylinder block face and the piston crown, commonly referred to as the 'deck height'.

Procedure:

Measure the volume of the cylinder and/or piston chambers using a suitable burette filled with paraffin. Calculate the volume of the gasket and deck height areas and add these to the chamber volume to arrive at the total compressed volume. Some engines with irregular piston crown shapes, especially raised areas, may be difficult to quantify with any degree of accuracy. In such cases it is best to measure the compressed area with the cylinder head fitted. Make sure the piston is at TDC and seal the gap between the cylinder wall and the piston with grease (this will prevent seepage past the rings giving a false reading). Refit gasket and cylinder head and measure the volume through the spark plug hole.

Note: The spark plug hole must be at the highest point when carrying out this procedure.

Calculation: $(\text{Cylinder volume} + \text{compressed volume}) \div \text{compressed volume}$.

Example: 1000cc 4 cylinder engine with a compressed volume of 27cc's.

Solution: One cylinder = $1000\text{cc} \div 4 = 250\text{cc}$.
 $(250\text{cc} + 27\text{cc}) \div 27\text{cc} = 277\text{cc} \div 27 = 10.26$ or 10.26:1 compression ratio.

Valve Size

The maximum airflow through any valve occurs when it has been lifted 25% of its diameter. For example, a 37mm (1.45") valve will require a lift of no more than 9.25mm (.364") and a 31mm (1.22") valve a lift of 7.75mm (.305") to reach their maximum flow capabilities.

Timing In The Camshaft

Rotate the crankshaft clockwise to 90 degrees after TDC. This will make sure all the pistons are half way down the bore. Now position the dial gauge so that it can read the lift of the inlet valve of number 1 cylinder from the top of the valve retainer. Rotate the cam until the gauge shows that the valve is at full lift. As with the crankshaft, there will be a dwell period where the valve is at full lift. True full lift is at the centre of this dwell period. Roughly position the cam at true lift position.

Now rotate the crankshaft clockwise to the full valve lift position (as specified on the camshaft data sheet - this figure is typically from 100 to 120 degrees after TDC), fit the timing belt or chain and set up the tensioner. Now rotate the crank clockwise until the inlet valve of number one cylinder is just off full lift position (such as 0.005" or 0.15mm). Record the figure on the timing disc from the pointer. Then continue to rotate the crank clockwise until the valve has fully opened and then closed by the same distance as previously used (0.005" or 0.15mm). Read the figure on the timing disc again. The position of full lift is the middle of these two figures. The full lift position can be calculated by adding the two figures together and dividing by two. Adjustments can then be made to the camshaft timing, using an adjustable cam pulley or offset dowels, if this figure does not agree with the one on the data sheet. Check the timing again after adjustments using the same procedure.

Having timed the camshaft, check that there is no piston to valve contact. Minimum clearance is 0.060" (1.5mm). This can only be checked by dummy building the engine with a piece of plasticine placed on the crown of the piston. As the engine is turned, the valves will indent the plasticine. The clearance is then measured as the thickness of the plasticine between the piston crown to the bottom of the valve indent. Before starting the engine, turn the engine over by hand to ensure that it turns freely. Prime the oil system and check that everything is set to ensure that the engine starts straight away. The engine must not be turned over for any length of time on the starter. Once started, do not allow the engine to idle for the first 20 minutes and keep the revs to a minimum of 2500 rpm. This

will ensure adequate lubrication of the cam and followers and reduce the contact force between the cam and follower. If any adjustments need to be made within the first 20 minutes, then shut the engine down. **DO NOT ALLOW THE ENGINE TO IDLE.** Please note that new hydraulic lifters may in some cases operate with excessive noise for a few minutes before they are fully charged with oil.

Performance Camshafts

All the Kent camshaft applications/part numbers below with the suffix 'P' are for the original pin drive oil pump/ camshaft. If you have changed your camshaft and oil pump to either 'Star' drive or 'Metro Slot', use the suffix 'S' or 'M' on the part number. All Piper cams with the suffix E are Star Drive unless otherwise stated.

To assist in selecting a suitable camshaft we have prepared a table showing their various characteristics, these will change from engine to engine and with other modifications such as carburettor or valve size. A scatter profile is where the cam timing on No.2 and 3 engine cylinders has been altered slightly to combat the poor scavenging of the siamese port design. This will benefit both the tickover and high end performance.

The effect of a larger engine is to lower the camshaft's power range slightly. Care must be taken to ensure that installation is carried out correctly and that components all work together or you will not get the expected power output or reliability. It is essential that the new cam is fitted with new followers as they mate with the lobe that they run on and should never be used on another lobe. Lightened and Tuftrided followers wear more slowly and put less load on high lift cam lobes: They are also manufactured with a drainage hole. Another essential is the special lubricant that must be used with all new cams, it provides vital lubrication during initial starting and protects your cam from extreme wear in its first minute of use. (S/T = Special Tuning) Don't forget the camshaft assembly lubricant or the cam timing degree disc (TT2929), you will need this to set your cam timing.

KENT CAMS CAMSHAFT TYPE	PART NO.	INLET	EXHAUST INL - EXH	DURATION	CAM LIFT	DESCRIPTION
Road	KMD256	21/53	53/21	220-254°	0.263"	998cc Street Cam
Fast Road	KMD266	24/56	61/29	260-270°	0.263"-0.270"	1275cc Smooth Idle
Road Rally	KMD276	29/61	66/34	270-280°	0.293"-0.315"	1275cc Slightly Lumpy Idle Very Good Street Cam
Rally	KMD286	34/66	71/39	280-290°	0.315"-0.324"	1275cc Lumpy Idle Max Street Cam
Rally Scatter	KMD286SP	34/66	71/39	280-290°	0.315"-0.324"	1275cc Lumpy Idle Max Street Cam
Race	KMD296	39/71	76/44	296-300°	0.324"-0.340"	1275cc Race/1380cc Slightly Lumpy
Race Scatter	KMD296SP	39/71	76/44	296-300°	0.324"-0.340"	1275cc Race/1380cc Slightly Lumpy
Full Race Scatter	KMD310SP	49/81	81/49	310°	0.340"	Full Race
S/T Road	STA600S	33/65	63/31	278-274°	0.293"	Classic Road Cam
S/T Fast Road/Rally	STA731	24/64	59/29	268°	0.263"	Classic Fast Road Cam
S/T Fast Road/Rally	STA800S	24/64	59/29	268°	0.263"	Classic Fast Road Cam
PIPER CAMSHAFT TYPE	PART NO.	INLET	EXHAUST INL - EXH	DURATION	CAM LIFT	DESCRIPTION
Fast Road (Stage 2)	AHR2702E	39/73	73/39	292°	0.288"	1275cc Fast Road Cam
Fast Road	AHR270E	37/71	73/39	288°	0.277"	1275cc Road Cam
Road Rally	AHR2852E	39/73	66/32	292-278°	0.299"	1275cc Max Street/1380cc Road Cam
Rally	AHR300E	46/74	74/46	300°	0.316"	1380cc Fast Road Cam
Sprint	AHR320E	54/82	82/54	316°	0.316"	Race
Race 2	AHR3202E	62/86	86/62	328°	0.322"	Full Race
ACCESSORIES	PART NO.					DESCRIPTION
Cam Lube	KEN2					250ml Cam Lubricant
Cam Timing Disc	TT2929					360° Timing Wheel

Carburettor Jet Selection

This is a quick guide to jet selection for 1275cc Weber carburettors.

Note: Jet selections shown are a basis to work from, they may need adjustment to suit your application, this can only be carried out on a rolling road.

1275cc WEBER CARBURETTOR	40 ROAD	45 FAST ROAD	45 FAST ROAD AND SPRINT	45 RACE
Auxiliary Venturi	3.5	4.5	4.5	4.5
Choke	34	36	38	40
Main Jet	145	150	170	200
Air Cor.	175	180	180	175
Emulsion Tube	F2	F2	F2	F2/F9
Pump Jet	45	50	55	55/60
Idle Jet	45F8	50F8	55F8	55F8

Suspension

Suspension Geometry

There are five basic factors that control front suspension geometry:

1. Kingpin Inclination.
2. Bump Steer.
3. Caster Angle.
4. Camber Angle.
5. Tracking.

Note: On a Mini only three of these can be altered easily.

Front Suspension

Kingpin Inclination

The Kingpin Inclination is not independently adjustable although it will alter as other adjustments are made.

Bump Steer

Bump steer is in fact a change in toe angle as a wheel moves up or down in its suspension travel. When a bump is encountered in a turn, the resulting toe change will cause a slight steering effect which is felt as anything from a slight "twitch" to a major direction change. This can be optimised but is far more complicated and would require specialist measuring tools.

Caster Angle

Caster angle this is left to the adjustable front tie bar kit (WPT9003X). This is quite an easy adjustment if the tie bar bushes (31G1155H road hard/31G1155VH race hard rubber or 31G1155SPK poly. bushes) are lubricated on installation, as the tie bar can actually be rotated (therefore lengthened or shortened) in situ.

Camber Angle

Camber angle is adjusted by the replacement of the lower arms with lengthened or adjustable length arms.

WPT9001X are 3/8 inch longer, giving 1.5 degrees more negative camber than standard.

WPT90012X are 1/2 inch longer, giving 2 degrees more negative camber than standard.

WPT90013X are 5/8 inch longer, giving 2.5 degrees more negative camber than standard.

C-AJU3363 rose jointed length adjustable, giving fully adjustment capabilities.

Again as with the tie bars it is advisable to use harder bushes (21A1882SPK) to achieve less free play.

Tracking

Tracking probably the most well known, is adjusted via the track rod end on the steering rack. This is not to be overlooked as with implementing the above modifications to the suspension your tracking is sure to have been affected and will require adjustment to bring back to the correct setting.

Note: If lowering the suspension or adding lots of negative camber, you will require lengthened track rod ends (GSJ158) as the standard ones may only be hanging on by a few threads.

Rear Suspension

Rear suspension, at the rear of the Mini we are really stuck with only track and camber adjustment.

Camber Angle

Camber angle is adjusted via the outer radius arm bracket. There are two types available fixed (WPT9002X) at 1.5 degrees, and adjustable (WPT90021). These adjustable brackets also allow the track to be adjusted. If purchasing the fixed camber brackets the track can be altered, to alter toe-in is quite a simple affair this is done by adding spacer shims between the radius arm outer bracket and the rear subframe and elongating the fixing holes on the underside of the radius arm bracket.

Adjusting toe-out is not so simple this requires the removal of the radius arms to allow access to the inner radius arm mount, this now requires the mounting hole for the radius arm pin to be elongated. Once the correct track has been found it will be necessary to lock this in position to stop it returning to toe-out after some suspension movement. This elongating of the inner mount brings with it another problem by raising the rear suspension. The thought of all this labour should have put off purchasing the fixed brackets and brought your attention to back to the adjustable brackets, in my view well worth the money and the sore knuckles.

Dampers, Springs & Adjustable Height Suspension

We supply three different manufacturers of suspension dampers for the Classic Mini SPAX, GAZ and KONI, all of them offering dampers with adjustment facilities on both bump and rebound. Nearly all offer this facility via an adjustment knob or screw on the lower body of the damper unit, this controls both the bump and rebound. This is the easiest method of adjusting your damper.

Koni on the other hand have a different method of adjustment which requires the shock to be removed and adjusted under compression. Although this sounds like a long job this really only takes about 1 hour tops and only this long because the fuel tank has to be repositioned while removing the left hand rear damper.



Front Dampers

GAC84011X	SPAX Shock Absorber - Standard Height.
GAC84021X	SPAX Shock Absorber - Lowered Height.
GAC8405X	KONI Shock Absorber - Standard Height.
GAC8046X	KONI Shock Absorber - Lowered Height.
GAC8041XG	GAZ Shock Absorber - Standard Height.
GAC8042XG	GAZ Shock Absorber - Lowered Height.

Rear Dampers

GAC84031X	SPAX Shock Absorber - Standard Height.
GAC84041X	SPAX Shock Absorber - Lowered Height.
GAC8407X	KONI Shock Absorber - Standard Height.
GAC8408X	KONI Shock Absorber - Lowered Height.
GAC8403XG	GAZ Shock Absorber - Standard Height.
GAC8404XG	GAZ Shock Absorber - Lowered Height.

These of course are only the damper units and not the spring unit; this job on a Classic Mini is left to a rubber cone. Perfect for the job in many ways it is a bit harsh for the requirements we expect today. There are several ways to change this harshness. The cheapest way is to remove the springs and drill holes into the rubber although this could take some time with trial and error (please see Dave Vizards'... How to Modify Your Mini book part number MGL0248).

We also supply replacement spring kits that actually replace the rubber cone units completely. These are available in two different spring rates. The softer of the two kits (FAM3968X) is the one we would recommend for road use as it is disciplined over bumps and pot holes yet still gives plenty of enjoyment in the corners. The firmer of the two kits (FAM3968HX) is the kit that we would recommend for fast road, sprint and possibly some competition applications.

There is also the choice of coilover damper/spring kits (SPCK19 lowered kit and SPCK20 standard height kit). These as the name suggests are one piece units, the damper units have top and bottom (height adjustable at the bottom) platforms to facilitate the fitment of a spring around the body of the damper. With these units you can remove nearly all of the other original spring components e.g: Rubber cone, suspension trumpets and knuckle joints. These kits come with their own top and bottom mounting brackets for the front and require slight modification to the rear inner arches to allow fitment of the dampers and 1.9" diameter springs. If staying with standard rubber cones or converting to the spring replacement it is still possible to have adjustable height suspension. This is done via adjustable suspension trumpets: These trumpets replace the standard trumpets and have a threaded adjuster to allow a huge range of adjustment.

Hi-Lo's

GAC8437X	Hi-Lo Adjustable Height Suspension Kit - Front And Rear.
GAC84371	Hi-Lo Adjustable Height Cones Kit - 2 x Hi-Lo Cones And 2 x 21A423.
GAC84372	Extension Rods (Pair) - Use With GAC84371 When Fitting To Rear Suspension.
GAC84374	Front Allen Bar - Allen Head Bar For Adjusting Suspension Heights.
GAC84373	Rear Allen Bar - Allen Head Bar For Adjusting Suspension Heights.

Adjusta Ride

GAC8432X	Adjusta-Ride Adjustable Height Suspension Kit - Front.
GAC8433X	Adjusta-Ride Adjustable Height Suspension Kit - Rear.

Useful Tools

GAC9424X	Cone Compressor Tool.
MTR4201	Caster/Camber Gauge. (This gauge allows you to correctly set up your suspension to get the best from your Mini where it excels most (the corners). Very easy to use supplied with instructions).

Note: Please remember that any change in height is going to affect other suspension geometry parameters and these will require checking and adjustment once the desired height has been reached.

Brakes

Over the 41 years of the Mini production life there have many upgrades to the braking systems. A summary of standard Mini brake fitment throughout its production life.

Drum Brakes

1959-1964 Front drum brakes with single leading shoes. Rear drum brakes. This system had only one hydraulic wheel cylinder fitted in each drum. This system was hardly adequate then and should only be kept if car is trying to retain OE specification.

1964-1985 Front drum brakes with twin leading shoes. Rear drum brakes. This system although an improvement on the single leading shoe setup is only just adequate for standard performance cars and again retaining OE specification.

Disc Brakes

1961-1964 7 inch disc brakes at the front, two pot calipers. Rear drum brakes. Fitted to the Mini Cooper 997cc. This system although discs still had a very small pad surface to disc area and because of this these were not all that good. Parts for this system are virtually impossible to find therefore making it hard to maintain.

1964-1969 7 inch disc brakes at the front, two pot calipers. Rear drum brakes. Fitted to the Mini Cooper 998cc. This system had redesigned callipers and larger pad to disc surface area. This system was better than the 997 system but for today's standards it is still a little poor. Good for standard 10 wheel applications.

1963-1974 7.5 inch disc brakes at the front, two pot calipers. Rear drum brakes. Fitted to the Mini Cooper S and Mini Clubman GT. Much larger pad to disc surface area and improved cooling efficiency. This along with a remote servo makes a very effective braking system for those who wish to keep their 10" wheels.

1974-1979 8.4 inch disc brakes at the front, two pot calipers. Rear drum brakes. Fitted to the Mini Clubman GT. The larger discs really help with the pad to disc surface area and the cooling. These systems were non served and still gave very good stopping power.

1985-2000 8.4 inch disc brakes at the front, two pot calipers. Rear drum brakes. Fitted to the Mini as standard.

1989 8.4 inch vented disc brakes at the front, four pot calipers. Rear drum brakes. Fitted to the ERA Turbo Mini.

Improving Your Mini's Brakes

Any Mini can have its brake improved by moving to the next standard upgrade, i.e: Single leading shoe to Twin leading shoe etc... But most of you will be more interested in converting either from drums to discs or from small discs to large discs or maybe even four pot calipers. First of all you should be honest with yourself with what you want from your braking system.



All of us would like to believe that we are overlooked, Eddie Irvine's (guess where I'm from) but the truth is usually that we are just spirited drivers who probably have to use our Saturday Mini race car as weekday commuter. Big discs and hard pads are great for the race track but in real life they can be noisy and juddery, and in the worst cases give poorer performance if the pads do not reach their working temperature.

The cheapest brake performance upgrade for all of the disc type systems is an upgraded pad swap. There are lots of manufacturers out there producing upgraded material pads.

Performance Brake Pads

GBP102G	EBC Green Pad Set 998 Cooper.
GBP102KV	EBC Kevlar Pad Set 998 Cooper.
GBP103G	EBC Green Pad Set Cooper S.
GBP103KV	EBC Kevlar Pad Set Cooper S.
8G8996	MINTEX M1144 Pad Set Cooper S.
STR505G	EBC Green Pad Set GT & 1984-On.
STR505KV	EBC Kevlar Pad Set GT & 1984-On.
STR5051	MINTEX M1144 Pad Set GT & 1984-On.
STR5052	MINTEX M1155 Pad Set GT & 1984-On.
GBP258	MINTEX 4 Pot Metro And Alloy Calipers.
TMG309474	MINTEX M1144 4 Pot Metro And Alloy Calipers.

Something usually overlooked when looking at braking systems is replacement over braided brake hoses these give you a firmer feel at the pedal as these hoses do not expand when pressurised as rubber hoses do.

If you wish to fit the ultimate in braking systems we have several 4 pot calipers and even 6 pots.

This kit is for 13 inch wheels only:

MT5411 6 Pot Vented Big Brake Kit. For 13" wheels where a no compromise front brake setup is required our big disc conversion can be used. This combines a one piece 6 pot caliper with a 265 x 18mm vented disc with separate alloy mounting bell. Supplied with fast road pads and front braided brake lines. This is a competition oriented brake upgrade as the calipers are not fitted with dust seals.



Identification Numbers

Engine Identification Numbers

850cc

8A	Austin Up To 25000.
8MB	Morris Up To 25000.
8AM	Austin & Morris 25000 On.
8AH	Austin & Morris Automatic.
8AJ	Austin & Morris closed circuit breathing.
8AK	Austin & Morris automatic with closed circuit breathing.
8WR	Wolseley Hornet & Riley Elf.
8AC	Moke.
85H/101	All variants 1969-On.

Note: Third suffix letter denotes compression type, L = Low, H = High, e.g: 8AM/U/H101 denotes high compression.

998cc

9WR	Wolseley Hornet & Riley Elf Mkll, pre closed circuit breathing.
9AD	Austin, Wolseley Hornet & Riley Elf Mkll with remote type gearbox and closed circuit breathing.
9AE	Wolseley Hornet & Riley Elf Mklll.
99H/-101on	Wolseley, Riley, Mini 1000, Clubman 1000 1970-On & Mklll with dished piston.
99H/791	Mini 1974-On with dished piston.
99H/997	1980-On A+ block, flat top pistons, economy fitment with 2.95 final drive.
99H/A97P	A+ block with dished pistons, pre-A+ gears, 3.44 final drive & 12" wheels.
998	A+ block with centre locating tag in main cap, 1985 onwards, Flat top piston with circlip gudgeon pin retention.
99H/B81	Up To engine number 127431.
99H/C20	Up To engine number 105023.
99H/997	From engine number 127422 with 2.95 final drive 99H/A35P.

Flat top piston with press fit gudgeon pin

99H/B81	From engine number 127432.
99H/C20	From engine number 105024.
99H/D80	

Flat top pistons with press fit gudgeon pin, lead-free cylinder head

99H/G30 or G32 or G33	
99H/F15 or F16	
99H/E20 or E21	
99H/D81	
LBB10089	

Dished pistons with circlip gudgeon pin retention

99H/B83P	Up To engine number 102908.
99H/B84P	Up To engine number 100216.

Dished pistons with press fit gudgeon pin

99H/B83P	From engine number 102909.
99H/B84P	From engine number 100217.

Dished pistons with press fit gudgeon pin, lead-free

99H/G31	
99H/E22	
LBB10175	

1100cc (1098cc)

10AMW/Ta	Clubman Estate and Austin 110 (ADO16 shape).
10H791	Clubman Saloon.
10H/-/H	All Austin 1100 2 & 4 door derivative Saloons (ADO16 shape).
10GR/Ta/H	MG1100 (ADO16 shape).
10GRB/Ta/H	MG1100 & Wolseley 1100 (ADO16).
10V/Ta/H	Vanden Plas 1100 (ADO16 shape).

997 Cooper

9F/Sa/H101	To 2637 except 19201 To 20410 (became 1070S).
------------	---

998 Cooper (January 1964 On)

9FA/Sa/H	MkI Austin pre closed circuit breathing.
9FD/Sa/H	MkI Morris up to engine number 1934, all Austin Mkll closed circuit breathing and

9FD/Xe/H	Morris Mkll from engine number 1935-33660 with closed circuit breathing.
99/-/H	4 synchro gearbox introduced. Last of manufacture 1969.

Cooper S Variants

970cc

9F/Sa/X	Engine numbers 29001-29003 with Tecalmit filter.
9FD/Sa/X	Closed circuit breathing introduced with Tecalmit filter.
9FE/Sa/X	Closed circuit breathing, oil filter with oil light switch introduced.
9F/Sa/X	Engine numbers 29039-30029 Purolator oil filter with oil light switch and closed circuit breathing.

1070cc

9F/Sa/H	Engine numbers 26501 To 33660 and 19201 To 20410.
9FD/Sa/H	Engine numbers 33661 To 33948 with closed circuit breathing and oil light switch in oil filter head.

1275cc

9F/Sa/Y	Engine numbers 31001 To 31504 pre closed circuit breathing with Purolator oil filter.
9FD/Sa/Y	Closed circuit breathing with oil light switch on filter housing after engine no.32178.
9FE/Sa/Y	Closed circuit breathing with oil light switch on Purolator filter housing and piston design change.
9F/Sa/Y	From engine number 32378 onwards, closed circuit breathing with Purolator filter with oil light switch, Aeg510 camshaft introduced at engine number 40006, cross-drilled EN40B crank at engine number 42730 and metal dipstick tube at engine number 42548 onwards.
12H397	Cooper S Mklll with dynamo, negative earth and Tuftrided EN16T crankshaft.
12H398	Cooper S Mklll with alternator, negative earth and Tuftrided EN16T crankshaft.

Note: Only Cooper S engines with prefix '9F' had EN40B forged steel, nitrided crankshafts. All other A-series engines had EN16T steel crankshafts which were only Tuftrided on Mklll 'S' and Austin 1300GT (ADO16) and were stamped 12G1683.

1275cc Solid Wall Block (No Tappet Chest Covers)

12G/Ta/H	ADO17 shape Wolseley, Riley, MG & Vanden Plas fitted with S rods.
12H379	1275GT with dynamo, negative earth, electric fuel pump and remote gearbox.
12H380	1275GT with alternator, negative earth, electric fuel pump and remote gearbox.
12H389	1275GT with dynamo, negative earth, mech. fuel pump and remote gearbox.
12H390	1275GT with alternator, negative earth, mech. fuel pump & remote gearbox.
12H706	1275GT with alternator, negative earth, mech. fuel pump & rod change gearbox.
12H397	Cooper S Mklll with dynamo and negative earth.
12H398	Cooper S Mklll with alternator and negative earth.
12H/-/	1275 Austin ADO16 & Allegro.
12H610/635	Innocenti Mini with duplex cam drive gears and 11-stud head.
12H719/832	Innocenti Mini with simplex cam drive gears and 11-stud head.



1275cc 1990 Onwards (12A Numbers)

12A/2A	Carburettor type.
12A/2B	Carburettor and catalyst type.
12A/2D	Spi (Single Point injection - Tbi, throttle body injection) with 9.4-1 CR.
12A/E	Spi (Tbi - throttle body injection) with 10-1 CR.

With the following suffixes:

F53	10.0-1CR, 3.105 final drive, catalyst, oil cooler.
F75	9.4-1CR, spi, 3.105 final drive, closed loop catalyst.
F76	9.4-1CR, automatic with closed loop catalyst.
F77	10.0-1CR, spi Cooper, 3.2 final drive, closed loop catalyst.
G01	10.0-1CR, 3.105 final drive, catalyst, no oil cooler.
G03	9.4-1CR, 3.105 final drive, catalyst, (May 1992-On).
G04	9.4CR, 2.76 final drive, catalyst, French only spec.
G05	9.4-1CR, automatic with catalyst.

Factory Replacement Engine Reference Numbers

(i.e. New, Gold Seal Units)

8G28	850cc - Oil feed to primary gear type crank with 1.375-inch tail shaft.
8G35	850cc - Deva bush conversion type crankshaft with 1.375-inch tail shaft.
8G45	850cc - Gold Seal, 1.5-inch self oiling primary gear/crankshaft type.
GSE1101E	850cc - Gold Seal unit.
RKM1101E	850cc - Silver Seal unit.
BHM1307E	850cc - Gold Seal unit, 85H prefix replacement.
8G18	997cc Cooper - Oil feed to primary gear type crankshaft.
8G29	997cc Cooper - Deva bush type primary gear and crankshaft.
8G36	997cc Cooper - Oil feed converted primary gear and crankshaft.
8G33	998cc Cooper - Fitted with 28G193 (12G202) cylinder head.
8G40	998cc Cooper - 28G222 (12G295) cylinder head introduced.
8G42	998cc Cooper - Closed circuit breathing rocker cover and side plates.
8G49	998cc Cooper - Purolator oil filter with oil light switch introduced.
GSE1103E	998cc Cooper - Gold Seal unit, was RKM1120E Silver Seal.
RKM1103E	998cc Cooper - Silver Seal unit.
8G57	998cc - New from 1969 and exchange for all pre-A+ To 1981.
GSE1102E	998cc - Gold Seal unit, was RKM1119E Silver Seal unit, pre-A+ To 1981.
RKM1119E	998cc - Silver Seal unit, replaced by RKM1102E, pre-A+ To 1981.
BHM1232	998cc - Low compression dished piston, CAM6267 camshaft, early cylinder head and crankshaft main bearings with side locator tag, A+.
BHM1377	998cc - High compression flat top piston, CAM4717 camshaft, early cylinder head and crankshaft main bearings with side locator tag, A+.
BHM1458	998cc - Low compression piston, CAM6267 camshaft, late A+ cylinder head and crankshaft main bearings with central locator tag, A+.
BHM1460	998cc - High compression press-fit wrist pin piston, CAM4717 camshaft, late A+ cylinder head and crankshaft main bearings with central locator tag, A+.
LBB10089	998cc - Low compression press-fit wrist pin piston, CAM6267 camshaft, lead free late A+ cylinder head and crankshaft main bearings with central locator tag, A+.
8G156E	1100cc - Clubman, Special and Austin 1100 (AD016).
RKM1150E	1100cc - Silver Seal unit for Clubman and Special.
RKM1151E	1100cc - Silver Seal unit for Clubman and Special.
BHM1042	1100cc - New and Gold Seal units for Clubman and Special, 1974-80.
BHM1229	1100cc - New & Gold Seal units for Clubman & Special, A+ Block, 1980-On.
8G38	970cc - Gold Seal unit, pre closed circuit breathing, Cooper S.
8G41	970cc - Gold Seal unit with closed circuit breathing side plates, Cooper S.
8G46	970cc - Gold Seal unit with oil light switch in filter housing, Cooper S.
8G133	1070cc - Gold Seal unit, pre closed circuit breathing, Cooper S.
8G153	1070cc - Gold Seal unit with closed circuit breathing side plates, Cooper S.
8G145	1275cc - Pre closed circuit breathing unit, Cooper S.
8G154	1275cc - Closed circuit breathing side plates unit, Cooper S.
8G155	1275cc - Oil filter housing with oil pressure light switch, Cooper S.
8G174	1275cc - Fitted with AEG510 camshaft, Cooper S.

38G464	1275cc - Introduced in 1970, most were fitted with EN16 Tuftrided crankshaft.
8G200	1275cc - New and Gold Seal units Clubman 1275GT.
38G527	1275cc - New and Gold Seal units for engine numbers prefixed 12H706, 12H707 and 12H831 for Clubman 1275GT.
RKM1130E	1275cc - Silver seal unit, was RKM1112E, for Clubman 1275GT, pre-A+.
RKM1152E	1275cc - Silver Seal unit for Clubman 1275GT, pre-A+.
RKM1112E	1275cc - Silver Seal unit for Clubman 1275GT, pre-A+.
BHM1220	1275cc - A+ unit for Clubman 1275GT.
8G199E	1275cc - Gold Seal unit with Duplex cam drive gears for 1300GT (AD016) and Innocenti 1300, 11-stud cylinder head.
38G559E	1275cc - Gold Seal unit with Simplex cam drive gears for engine numbers prefixed 12H719 and 12H832, for 1300GT (AD016) and Innocenti 1300, 11-stud cylinder head.
GSE1109E	1275cc - Gold Seal unit for 1300GT (AD016) and Innocenti 1300, 11-stud cylinder head.
RKM1133E	1275cc - Silver Seal unit for 1300GT (AD016) and Innocenti 1300, 11-stud cylinder head.
BHM1209E	1275cc - Gold Seal unit, replaced all Innocenti 1300 engines from engine numbers prefixed 12H610, 12H635 and 12H832.

Note: All engines pre-fixed with 'GSE' or 'RKM' were of UNIPART origin when BL split it's parts organisation.

'E' at the end of a part number denotes it is a reconditioned, service unit only (basic engine assembly with no ancillaries).

'N' at the end of a part number denotes a brand new unit.

Standard Production Crankshaft Identification

Below is a list of crankshaft identification data by forging or stamped numbers - yes, contrary to what many say/express, all cranks are forged. None are cast. They wouldn't last 2 minutes in an engine if they were cast - they'd be way too brittle. The differences are in the material used, finish machining detail and any heat treatments applied.

It is by no means complete and utterly correct/infalible since Austin/Morris, British Leyland, Leyland Cars, Austin Rover, Rover, et al were seriously prone to not adhering to specifications and applications lists. But it is better than nothing at all!

22A62	850cc - Early type with oil feed for primary gear, 1.375" dia. tail.
22A63	850cc - Early type with oil feed for primary gear, 1.375" dia. tail.
22A298	850cc - Early type thin-nose crank, 1.375" dia. tail.
12A670	850cc - Later type with 1.5" dia. tail.
12A298	997cc - Original Cooper crank.
12A375	997cc - Cooper crank with oil feed hole for primary gear.



12A595	998cc - Early EN16T spec.
12A1451	998cc - Later, pre-A+ EN16T spec.
BHM1436	998cc - A+ spec, 1985-On (12A1451 forging).
12G82	1100cc - Standard across the board transverse A-series EN16T spec.
AEG330	970cc - EN40B forged, non-cross drilled.
AEG171	1071cc - EN40B forged, non-cross drilled.
AEG315	1275cc - Cooper S, EN40B forging, Nitrided, 1.625" dia. big ends, non-cross drilled.
AEG316	1275cc - Cooper S, EN40B forging, Nitrided, 1.625" dia. big ends, non-cross drilled.
AEG479	1275cc - Cooper S, EN40B forging, Nitrided, 1.625" dia. big ends, cross drilled.
AEG480	1275cc - Cooper S, EN40B forging, Nitrided, 1.625" dia. big ends, cross drilled.
AEG623	1275cc - Cooper S, EN16T forging, Tuftrided, 1.625" dia. big ends.
12G1287	1275cc - Non-S, EN16T with 1.625" dia. big ends.
12G1288	1275cc - Non-S, EN16T with 1.625" dia. big ends.
12G1505	1275cc - Non-S, EN16T with 1.75" dia. big ends.
12G1683	1275cc - 12G1505 forging, non-S, EN16T with 1.75" dia. big ends, Tuftrided.
CAM6232*	1275cc - Rolled-fillet radius on bearing journals, A+ with 1.75" dia. big ends.

*Note: This crankshaft was used in all 1275cc, A+, transverse engines including the MG Metro Turbo. There are various unconfirmed opinions on the subject of whether the material was any different, or whether it was heat treated differently. It would appear that early Turbos had just the standard spec, EN16T, non-heat treated type fitted.

Later examples certainly appear to have been heat-treated, probably an up-to-date, emissions-friendly version of 'Tuftriding' (a recognised ICI registered process) - possibly a forerunner to Nitro-Carburising. These crankshafts have a distinctly charcoal-grey/black finish - mostly detectable on the webs, water pump/alternator pulley end and in the rolled fillet radii. The later being fairly 'deaf' and very even.

Compression ratio is hugely important to an engines performance, work out your compression ratio and the combustion chamber volume you need, make sure the head you are buying - especially if its of the shelf - has the right volume. David Vizards book 'Tuning the a series engine' has invaluable information in it concerning this.

Valve sizes are no guarantee of flow, just because it has big valves does not mean it flows big, take a valve out and look into the port, the guide should be bullet nosed, and is the seat unnecessarily wide, maybe a wide 'pre cut' to the seat? Are the seats cut accurately for height, run your fingers across inlet and exhaust differences - are they the same for all the chambers?

Look down into the ports, is there a raised section around the guide (a boss), all our heads have these removed for full flow is the finish consistent across all the ports, and not highly polished - a polished finish can actually reduce power due to fuel being drawn out of the air, due to surface tension.

Hold a suitable gasket up to the manifold and chamber faces, have the chambers and ports been accurately modified? Usually on cheaply modified heads the ports are flared out to meet the gasket giving the appearance but not performance.

Cylinder Head Casting Numbers

Number	Inlet Dia.	Exhaust Dia.	Nom. cc	Standard fitment
2A628	1.0625"/26.99	1.00"/25.4	24.5	850, 998 Mini & 948 Sprite
2A629	1.0625"/26.99	1.00"/25.4	24.5	948, A35 & Morris Minor
12A1456	1.0625"/26.99	1.00"/25.4	24.5	850, 998 Mini & 948 Sprite
12G202	1.156"/29.36	1.00"/25.4	26.1	997 Cooper, Austin 1100 Mk
CAM4180	1.0625"/26.99	1.00"/25.4	25.5	998 Mini A+ (80 on) & lead free
12G206	1.218"/30.93	1.00"/25.4	28.3	Early 998 Cooper, MG1100
12G295	1.218"/30.93	1.00"/25.4	28.3	998 Cooper, MG1100
12A185	1.401"/35.6	1.22"/31.0	21.4	First MkI Cooper S
AEG163	1.401"/35.6	1.22"/31.0	21.4	Later MkI & MkII Cooper S
12G940*	1.312"/33.33	1.15"/29.2	21.4	1275GT, Austin 1300, late A+ model inc. Turbo not MG Metro
12G940	1.401"/35.6	1.15"/29.2	21.4	12G1805 Stamped on flat area by thermostat MG1300, 1300GT & MkIII Cooper S as above plus MG Metro
12G940*	1.401"/35.6	1.15"/29.2	21.4	

*Note: A+ head castings - despite having the same 12G940 casting number - are considerably different in appearance, loosing the flat area behind the thermostat housing and around the rest of the rocker/head stud areas to a sculptured look - where these areas are replaced by a 'sunken' cast finish.

The A+ castings were introduced with the appearance of the Metro in 1980, although some late 1275GTs 1979-On had them fitted. Generally they are easily recognised by their colour - a putrid yellow on the small-bore castings and bright red on the large-bore ones, a paint finish that is VERY difficult to remove, even in a chemical tank. The MG Metro Turbo shares the same valve sizes with the other non-'big valve' 12G940 variants but has 8mm valve stems, sodium-filled exhaust valves.

A+ heads generally have three collet grooves in the valves, collets are 14-degree cone taper instead of the 10-degree on single groove collets (so parts are not interchangeable) and the top-caps have a raised ridge around the collet hole.

Car Identification

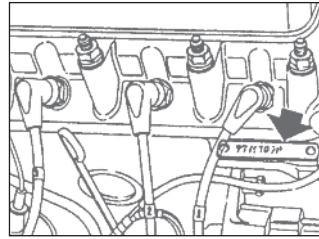

Engine Numbers

The engine number is located immediately above the alternator.

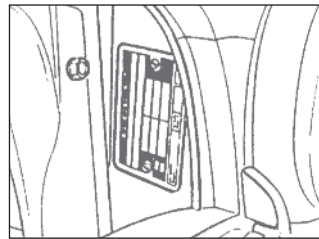

Cars Produced Between 1980-84

In 1980 the use of the vehicle identification numbers was introduced. The V.I.N. plate is located on the left hand fitch, in front of the radiator.

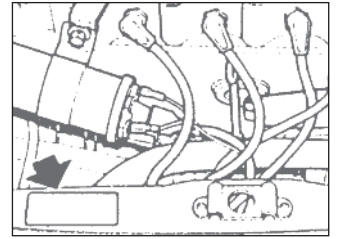

Cars Produced Up To 1979

The commission number can be found on a red plate fitted to the bonnet slam panel.

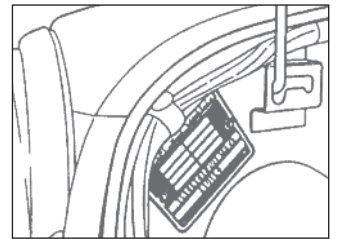

Cars Produced After 1984

The V.I.N. plate can be found fitted to the right hand fitch, near the bonnet prop locating bracket.

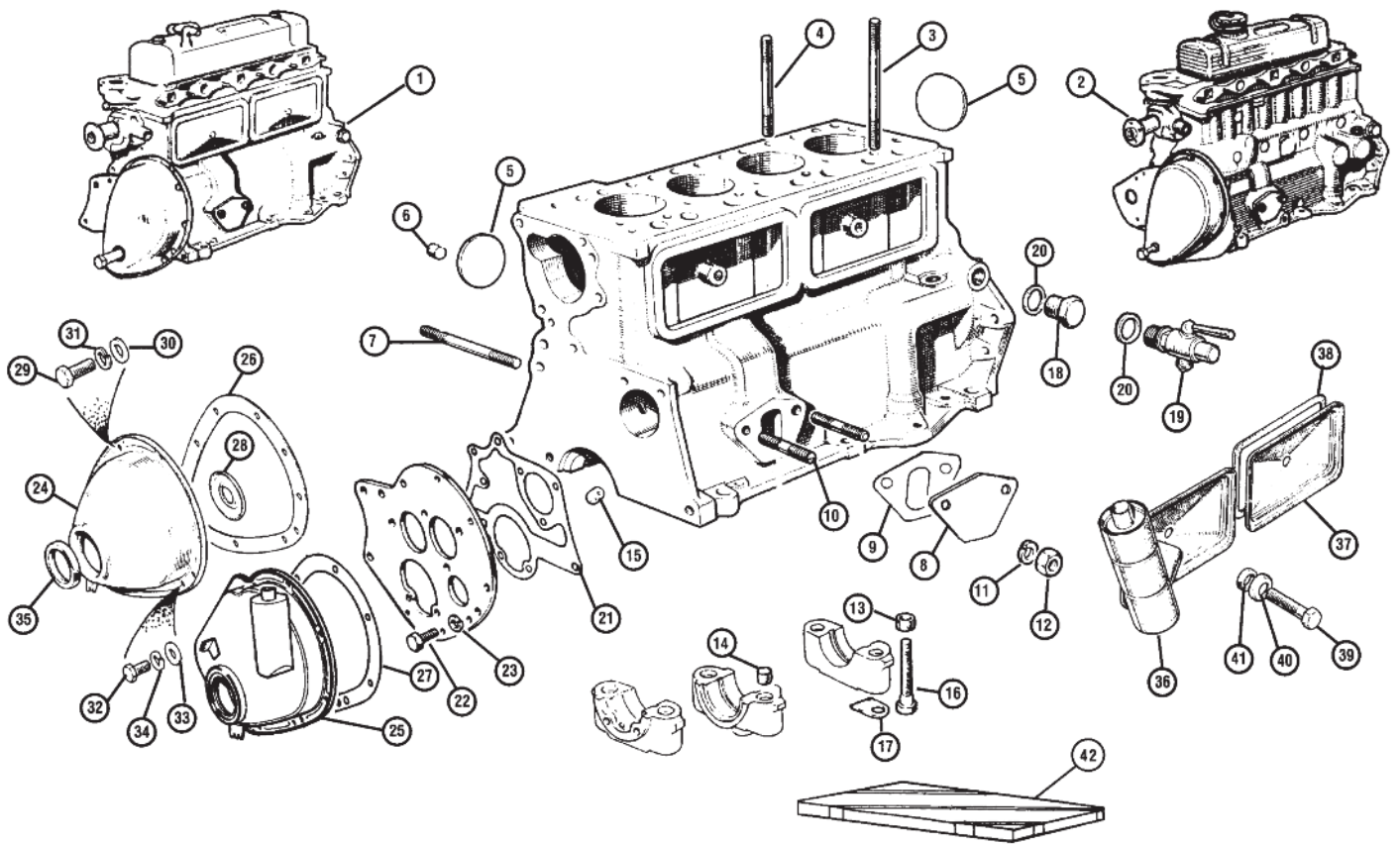

ill. Part Number Price £ea. Description Req. Details

Replacement Engines

1 8G57E £1,206.40 ENGINE, 998cc, rebuilt 1 pre A+

Engine Units (Lead Free)

Abbreviations for replacement engines: HC = High Compression, LC = Low Compression

1 LBB10175E £1,192.30 ENGINE, 998cc, exchange 1 LC A+
 LBB10089E NCA ENGINE, 998cc, exchange 1 HC A+
 2 LBB10399E £1,496.60 ENGINE, 1275cc, exchange 1 Cooper 1300cc & SE
 MT1101 NCA ENGINE, 1293cc, exchange 1 A+
 MT1102 NCA ENGINE, 1293cc, exchange 1 A series
 MT1103 NCA ENGINE, 1380cc, exchange 1 A+
 MT1104 NCA ENGINE, 1380cc, exchange 1 A series

Note: Old units must be clean and in a re-buildable condition. Old units will be checked before refunding any surcharge. If you wish to convert to lead free fuel, you will need to re-set the ignition timing.

Cylinder Block Components

3 CAM150 £4.43 STUD, cylinder head, long 4
 AEG248 £10.90 BOLT, cylinder head 1 Cooper S only
 4 CAM151 £3.18 STUD, cylinder head, short 5/4 qty. reduced with
 TAM1617 £7.00 STUD, cylinder head 1 when coil bracket fitted
 TMG10864 £194.20 STUD KIT, competition 1 9 studs and nuts, (Kent Cams)
 MGS10864 £231.20 STUD KIT, competition 1 11 studs and nuts, (Kent Cams)
 AHT280 £70.00 STUD KIT, competition 1 11 studs and nuts EN24 Nickel Chrome Moly
 5 2K8169 £1.00 CORE PLUG, (1 5/8") 4 pre A+ models
 AEC876 £1.62 CORE PLUG, (1 5/16") 5 all A+ models
 AEH592 £1.20 CORE PLUG, (1.647) 4 Cooper S
 6 2K1345 £2.06 PLUG, oil release 2 To 1985
 TAM2009 NCA PLUG, oil release 2 1985-On
 7 CHS2613 £1.45 STUD, filter head to block 2 all 998cc models
 LYG10008 £2.12 SCREW, filter head to block 2 Cooper 1300cc
 BH605301 £1.92 BOLT, filter head to block 2 paper element
 8 2A265 £4.27 BLANKING PLATE, fuel pump 1 when fitting electric
 2A265K £6.30 BLANKING PLATE KIT, fuel pump 1 pump
 (Includes blanking plate, gasket & hardware).
 9 2A113 £0.62 GASKET, fuel pump/blanking plate* 1
 10 CHS2515 £1.36 STUD, fuel pump 2
 SH505071 £0.42 BOLT, fuel pump/blanking plate 2 Cooper 1097cc
 (All models except vehicles prior to engine number 12a/15633. Also suitable for pre A+ engines if used with original type blanking plate).
 11 GHF332 £0.28 WASHER, locking 2
 12 GHF201 £0.12 NUT 2
 13 2A54 £0.65 COLLAR, main cap location 6 all 998cc models
 14 12G1268 £5.00 DOWEL, main cap 6 Cooper 1300cc
 15 1A1964 £2.63 RESTRICTOR, camshaft oil feed 1
 16 12A1910 NCA BOLT, main cap 6 all 998cc models
 12G1398 £2.50 BOLT, main cap 6 Cooper 1300cc
 17 6K927 £1.10 LOCKTAB, main bearing 6 pre A+ 998cc only
 CMS1000 £8.50 MAIN STRAP, centre 1000 1 the main cap must be machined
 (Includes: longer high tensile bolts).
 CMS1300 £8.50 MAIN STRAP, centre 1300 1 the main cap must be machined
 (Non S inc: longer high tensile bolts).

Note: Centre main straps are used to help reduce flexing in the crank on modified engines.

18 53K2853 £6.14 PLUG, blanking 1
 19 3H576 £20.40 TAP, block draining 1 alternative to 53K2853
 20 6K638 £0.28 WASHER 1
 21 12G619B £1.36 GASKET, front plate* 1 without tensioner
 GUG705554GM £1.70 GASKET, front plate 1 with tensioner
 22 GHF120 £0.28 SCREW, front plate to main cap 2 998cc
 53K2016 £0.73 SCREW, front plate to main cap 2 Cooper 1300cc
 AEA687 £1.00 SCREW SET, front plate to main cap 2 when duplex fitted
 23 GHF332 £0.28 WASHER, locking 2 998cc
 WE600041 £0.42 WASHER, locking 2 Cooper 1300cc
 24 12G2506 NCA TIMING COVER, pre tensioner 1 998cc pre A+
 25 CAM4904 NCA TIMING COVER, pad type tensioner 1
 CAM4868 £66.50 TIMING COVER, with breather 1 Cooper 1300cc
 LJR10168 £62.90 TIMING COVER, with breather 1 1991-On
 26 12A956B £1.32 GASKET, timing cover* 1 without tensioner
 27 GUG705550GM £1.60 GASKET, timing cover 1 with tensioner
 28 12A1148 £2.70 OIL THROWER 1

ill. Part Number Price £ea. Description Req. Details

29 SH604031 £1.04 SCREW, cover to front plate 6
 30 GHF300 £0.19 WASHER 6
 31 GHF331 £0.17 WASHER, locking 6
 32 GHF120 £0.28 SCREW, cover to block 5
 33 GHF301 £0.22 WASHER 5
 34 GHF332 £0.28 WASHER, locking 5 } 1991-On
 35 88G561 £2.23 OIL SEAL, timing cover* 1 } 998cc model
 LUF10006 £5.90 OIL SEAL, timing cover 1 } 1300cc 1991-On
 36 12A1212 £22.00 TAPPET COVER, with breather 1 }
 37 12A1386 NCA TAPPET COVER, no breather 1 } early 1970's
 38 GUG5505GM £1.30 GASKET, tappet cover* 2 } & 1991-On
 39 BH605101 £0.79 BOLT, tappets cover 2 } 998cc models
 40 12A1177 £1.04 CUP WASHER 2 }
 41 12A1176 £1.10 SEAL* 2 }
 MRC1980A £1.00 SEAL* 2 } alternative to 12A1177 & 12A1176

*Note: Gaskets and seals marked are included in the gasket sets shown below.

42 GUG1543CS £39.80 GASKET SET, conversion 1 998cc pre A+
 GUG1543CSZ £16.00 GASKET SET, conversion 1 998cc pre A+
 GUG1509CS £13.20 GASKET SET, conversion 1 998cc A+
 GUG701615CS NCA GASKET SET, conversion 1 1275cc
 AJM206Z £14.80 GASKET SET, conversion 1 1275cc
 GUG701619CS £38.90 GASKET SET, conversion 1 Cooper 1300cc

Engine Paints

CCEP3A £17.20 ENGINE PAINT, BMC green 1 spray can
 CCEP3ABR £20.15 ENGINE PAINT, BMC green 1 brush
 CCEP4 £17.20 ENGINE PAINT, black 1 spray can
 CCEP4BR £20.15 ENGINE PAINT, black 1 brush
 CCEP10 £17.20 ENGINE PAINT, red 1 spray can
 CCEP10BR £20.15 ENGINE PAINT, red 1 brush
 CCEP11 £17.20 ENGINE PAINT, yellow 1 spray can
 CCEP11BR £20.15 ENGINE PAINT, yellow 1 brush

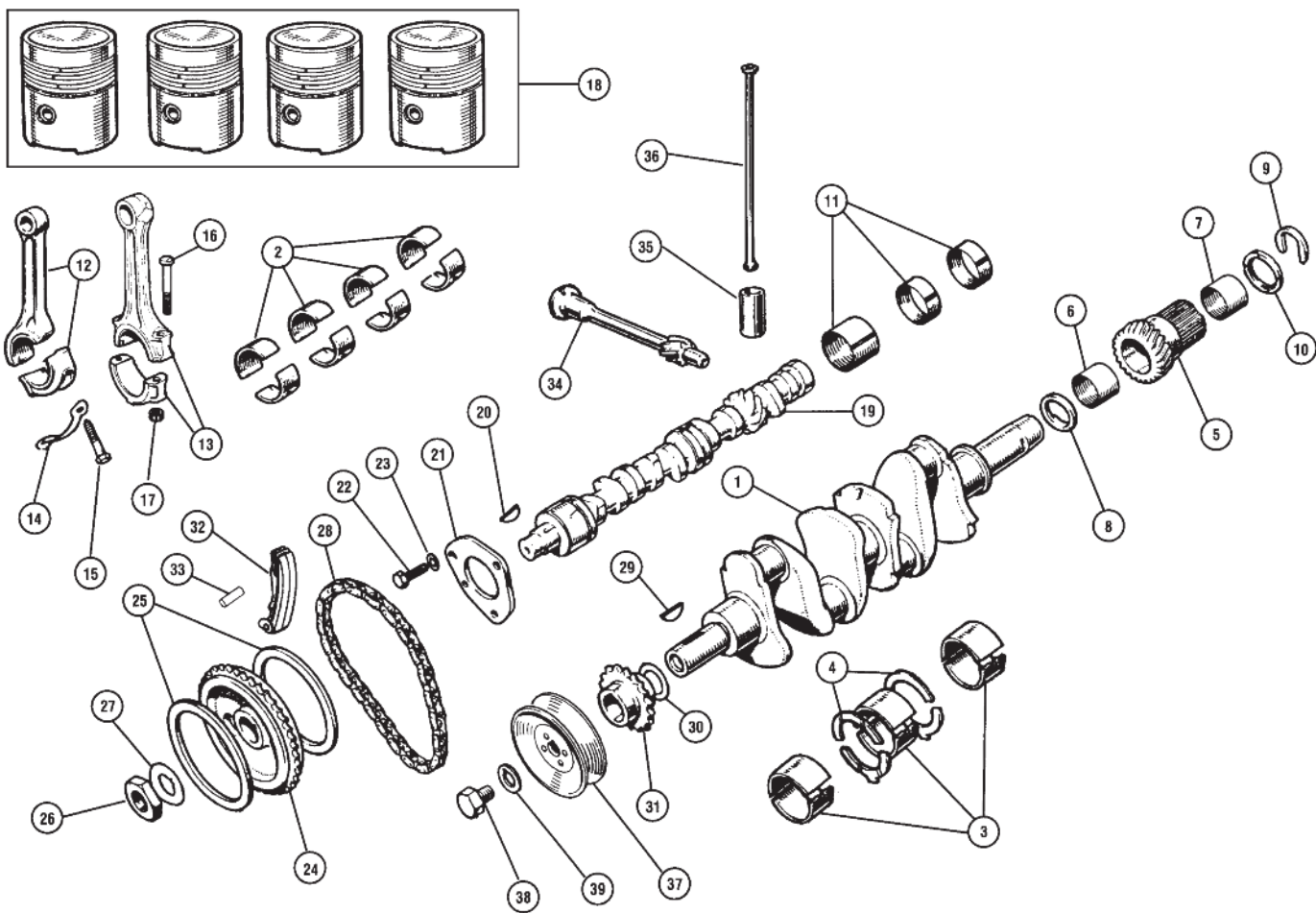

Ill.	Part Number	Price £ea.	Description	Req.	Details
Internal Engine Components					
1	8G2733R	£424.40	CRANKSHAFT	1	998cc To 1984 inc: bearings
	BHM1436	NCA	CRANKSHAFT	1	998cc 1985-On
	12A1451	NCA	CRANKSHAFT	1	998cc
	CAM6232	NCA	CRANKSHAFT	1	Cooper 1300cc

Note: These crankshafts are also available on an exchange basis, they are supplied with bearings and thrust washers to the appropriate size.

2	8G2198	£18.00	BEARING SET, con rod, std	1	850cc
	8G2198/10	£18.00	BEARING SET, con rod, 0.010"	1	998cc & 1098cc
	8G2198/20	£18.00	BEARING SET, con rod, 0.020"	1	
	8G2198/30	£18.00	BEARING SET, con rod, 0.030"	1	
	8G2198/40	£18.00	BEARING SET, con rod, 0.040"	1	
	8G2553	£27.70	BEARING SET, con rod, std	1	Cooper 1300cc
	8G2553/10	£27.70	BEARING SET, con rod, 0.010"	1	
	8G2553/20	£27.70	BEARING SET, con rod, 0.020"	1	
	8G2553/30	£27.70	BEARING SET, con rod, 0.030"	1	
	8G2553/40	NCA	BEARING SET, con rod, 0.040"	1	
3	8G2332	£30.60	BEARING SET, main, std	1	998cc A and A + To 1984
	8G2332/10	£30.60	BEARING SET, main, 0.010"	1	locating lip on both halves
	8G2332/20	£30.60	BEARING SET, main, 0.020"	1	
	8G2332/30	£30.60	BEARING SET, main, 0.030"	1	
	8G2332/40	£19.80	BEARING SET, main, 0.040"	1	
	8G2391	£21.60	BEARING SET, main, std	1	1098-1275cc
	8G2391/10	£21.60	BEARING SET, main, 0.010"	1	GT 1969-80, locating
	8G2391/20	£21.60	BEARING SET, main, 0.020"	1	tabs on edge of
	8G2391/30	£21.60	BEARING SET, main, 0.030"	1	upper and lower
	8G2391/40	£21.60	BEARING SET, main, 0.040"	1	halves
	BHM1573	£41.70	BEARING SET, main, std	1	998cc A + 1984-On
	BHM1573/10	£41.80	BEARING SET, main, (0.010")	1	these bearings
	BHM1573/20	£40.50	BEARING SET, main, (0.020")	1	were used until the
	BHM1573/30	NCA	BEARING SET, main, (0.030")	1	introduction of
	BHM1573/40	NCA	BEARING SET, main, (0.040")	1	colour coding
	BHM1574	£42.60	BEARING SET, main, std	1	1275cc A + 1990-On,
	BHM1574/10	£42.60	BEARING SET, main, 0.010"	1	locating tabs on
	BHM1574/20	£42.00	BEARING SET, main, (0.020")	1	edge of upper half
	BHM1574/30	£47.00	BEARING SET, main, (0.030")	1	and centre of
	BHM1574/40	NCA	BEARING SET, main, (0.040")	1	lower half
	LEB10001CN	NCA	BEARING, upper/red	3	998cc (each)
	LEB10002CNX	NCA	BEARING, lower/red	3	engine No:
	LEB10001HE	NCA	BEARING, upper/green	3	99HD81/105361 On
	LEB10002HE	NCA	BEARING, lower/green	3	99HE20/111592 On
	LEB10001FM	NCA	BEARING, upper/yellow	3	99HE21/102215 On
	LEB10002FMK	NCA	BEARING, lower/yellow	3	99HE22/104631 On
					99H F15-F16-F32- G30-G31-G32-G33- G34-G39
	CDU4062	NCA	BEARING, upper/red	3	
	CDU4065	NCA	BEARING, lower/red	3	
	CDU4063	NCA	BEARING, upper/green	3	
	CDU4063/10	£18.20	BEARING, upper/green (+0.010")	3	Cooper 1300cc (each)
	CDU4066	NCA	BEARING, lower/green	3	
	CDU4066/10	£7.50	BEARING, lower/green (+0.010")	3	
	CDU4064	NCA	BEARING, upper/yellow	3	
	CDU4067	NCA	BEARING, lower/yellow	3	
4	BHM1292	£12.50	THRUST WASHER SET, (4), (std)	1	
	BHM1292/3	£15.50	THRUST WASHER SET, (4), (0.003")	1	all 998cc models
	BHM1292/10	NCA	THRUST WASHER SET, (4), (0.010")	1	
	BHM1292/30	NCA	THRUST WASHER SET, (4), (0.030")	1	
	BHM1293	£14.40	THRUST WASHER SET, (4), (std)	1	
	BHM1293/5	£12.60	THRUST WASHER SET, (4), (0.003")	1	Cooper 1300cc
	BHM1293/30	£20.00	THRUST WASHER SET, (4), (0.030")	1	
5	22A1493	£137.30	PRIMARY GEAR, 24 teeth	1	998cc pre A+
	DAM8888	£180.00	PRIMARY GEAR, 29 teeth	1	998cc A+
	22G1053	£160.00	PRIMARY GEAR, 24 teeth	1	1275cc pre A+
	DAM8890	£310.20	PRIMARY GEAR, 29 teeth	1	Cooper 1300cc
	CSTR122	£126.40	PRIMARY GEAR, 22 teeth (Use this straight cut gear with EVO idler CSTR30/A/T/TA and input CSTR230/240/250).	1	1275cc s/cut EVO
	CSTR123	NCA	PRIMARY GEAR, 23 teeth (Use this straight cut gear with EVO idler CSTR30/A/T/TA and input CSTR230/240/250).	1	1275cc s/cut EVO

Please note: EVO drop gears are interchangeable to give different ratios. Easier than changing differential ratios.

6	22G109	£12.00	BUSH REAR, primary gear	1	
7	DAM8887	£20.20	BUSH FRONT, primary gear	1	small bore
	DAM8889	£16.00	BUSH FRONT, primary gear	1	large bore
	DAM8889X	NCA	BUSH FRONT, primary gear	1	large bore floating
	MRAC104	£218.60	DROP GEARS S/C, straight cut set	1	1-1 ratio 1275cc A+

8	22A321	£16.20	THRUST WASHER, (0.110/0.112")	1	
	22A322	NCA	THRUST WASHER, (0.112/0.114")	1	
	22A323	£21.60	THRUST WASHER, (0.114/0.116")	1	all 998cc models
	22A324	NCA	THRUST WASHER, (0.116/0.118")	1	
	22A450	NCA	THRUST WASHER, (0.118/0.120")	1	
	DAM6490	£42.30	THRUST WASHER, (0.112/0.114")	1	
	DAM6486	£32.00	THRUST WASHER, (0.114/0.116")	1	
	DAM6487	£44.70	THRUST WASHER, (0.116/0.118")	1	Cooper 1300cc
	DAM6488	NCA	THRUST WASHER, (0.118/0.120")	1	
	DAM6489	NCA	THRUST WASHER, (0.120/0.122")	1	
9	22A319	£9.50	'C' CLIP, primary gear retainer	1	
10	88G549	NCA	THRUST WASHER, rear	1	
11	BHM1211	£23.70	BEARING SET, camshaft	1	all 998cc models
	BHM1210	£16.50	BEARING SET, camshaft	1	Cooper 1300cc
12	12G123	£67.00	CON ROD, numbers 2 & 4	2	998cc with 'floating'
	12G126	£66.00	CON ROD, numbers 1 & 3	2	gudgeon pin
	12A1997	£150.00	CON ROD, numbers 2 & 4	2	998cc A+ with 'press
	12A1999	£150.00	CON ROD, numbers 1 & 3	2	fit' gudgeon pin
13	BHM1137	£99.10	CON ROD, (set of 4)	1	Cooper 1300cc
	AEG624	£156.20	CON ROD, (single)	4	Cooper S 1.625 big ends
14	2A660	£1.10	LOCK TAB	4	pre 998cc A+
15	12G2217	£7.80	BOLT, big end	8	
	CAM6126	£5.20	BOLT, big end	8	998cc A+
	TMG10880	NCA	BOLT, big end, uprated	8	848-1098cc
16	LFH10006	£5.50	BOLT, big end	8	Cooper 1300cc
	MGS10880	£136.70	BOLT, big end uprated (Car set supplied with nuts)	1	Cooper S 1275cc 12G engine
	TMG10781	£118.00	BOLT, big end uprated (Car set supplied with nuts)	1	Pre A+ 1275cc 12H engine
17	13H5872	£2.05	NUT, big end bolt	8	Cooper 1300cc
	AEG147	£1.90	NUT, big end bolt	8	Cooper S 1071cc & 1275cc
18	12A120	£178.00	PISTON SET, 8.3:1 CR, dished, std	1	
	12A120/20	£178.00	PISTON SET, 8.3:1 CR, dished, +20	1	848cc,
	12A120/30	£178.00	PISTON SET, 8.3:1 CR, dished, +30	1	5 ring,
	12A120/40	£178.00	PISTON SET, 8.3:1 CR, dished, +40	1	pinch bolt
	12A120/60	£178.00	PISTON SET, 8.3:1 CR, dished, +60	1	
	ADU3922	£174.00	PISTON SET, 8.3:1 CR, dished, std	1	
	ADU3922/20	£174.00	PISTON SET, 8.3:1 CR, dished, +20	1	998cc,
	ADU3922/30	£174.00	PISTON SET, 8.3:1 CR, dished, +30	1	4 ring,
	ADU3922/40	£174.00	PISTON SET, 8.3:1 CR, dished, +40	1	circlip fit
	ADU3922/60	£174.00	PISTON SET, 8.3:1 CR, dished, +60	1	
	CPS1015	£215.80	PISTON SET, 8.4:1/9.1:1 CR, flat, std	1	
	CPS1015/20	£215.80	PISTON SET, 8.4:1/9.1:1 CR, flat, +20	1	998cc,
	CPS1015/30	£215.80	PISTON SET, 8.4:1/9.1:1 CR, flat, +30	1	3 ring,
	CPS1015/40	£215.80	PISTON SET, 8.4:1/9.1:1 CR, flat, +40	1	circlip fit
	CPS1015/60	£215.80	PISTON SET, 8.4:1/9.1:1 CR, flat, +60	1	
	TAM2052	£196.00	PISTON SET, 10.3:1 CR, flat, std	1	
	TAM2052/20	£196.00	PISTON SET, 10.3:1 CR, flat, +20	1	998cc A+
	TAM2052/30	£196.00	PISTON SET, 10.3:1 CR, flat, +30	1	3 ring,
	TAM2052/40	£196.00	PISTON SET, 10.3:1 CR, flat, +40	1	press fit
	TAM2052/60	£196.00	PISTON SET, 10.3:1 CR, flat, +60	1	
	TAM2050	£194.40	PISTON SET, H/C, dished, std	1	
	TAM2050/20	£194.40	PISTON SET, H/C, dished, +20	1	1275cc,
	TAM2050/30	£194.40	PISTON SET, H/C, dished, +30	1	3 ring,
	TAM2050/40	£194.40	PISTON SET, H/C, dished, +40	1	press fit
	TAM2050/60	£194.40	PISTON SET, H/C, dished, +60	1	
	CAJJ3382/20	NCA	PISTON, flat, +20	4	
	CAJJ3382/40	£74.00	PISTON, flat, +40	4	1275cc,
	CAJJ3382/60	£74.00	PISTON, flat, +60	4	supplied
	CAJJ3378/20	NCA	PISTON, 6.5cc dish +20	4	individually
	CAJJ3378/40	NCA	PISTON, 6.5cc dish +40	4	
	CAJJ3378/60	£74.00	PISTON, 6.5cc dish +60	4	

Camshafts

19	AEA630	£120.00	CAMSHAFT, pin drive	1	998cc pre A+
	CAM6267	NCA	CAMSHAFT, slot drive (Engine codes: 99H/B83P/B85P/D83P/E22).	1	998cc A+
	CAM4717	NCA	CAMSHAFT, slot drive (Engine codes: 99H/B81P/B82P/D80P/D81P).	1	998cc A+
	CAM6648	NCA	CAMSHAFT, slot drive	1	Cooper 1300cc
	KMD266S	£148.00	CAMSHAFT, fast road, star drive	1	smooth idle in 1275cc+
	KMD276S	£148.00	CAMSHAFT, road/rally, star drive	1	slightly lumpy idle in 1275cc (Very good street cam).
	KMD286S	£148.00	CAMSHAFT, rally, star drive	1	slightly lumpy idle in 1275cc (Max street cam).
	KMD296S	£148.00	CAMSHAFT, race, star drive	1	1380cc+
	KMD310S	NCA	CAMSHAFT, full race, star drive	1	lumpy idle in 1380cc
	KMD266KS	NCA	CAMSHAFT KIT, fast road, star drive	1	smooth idle in 1275cc+

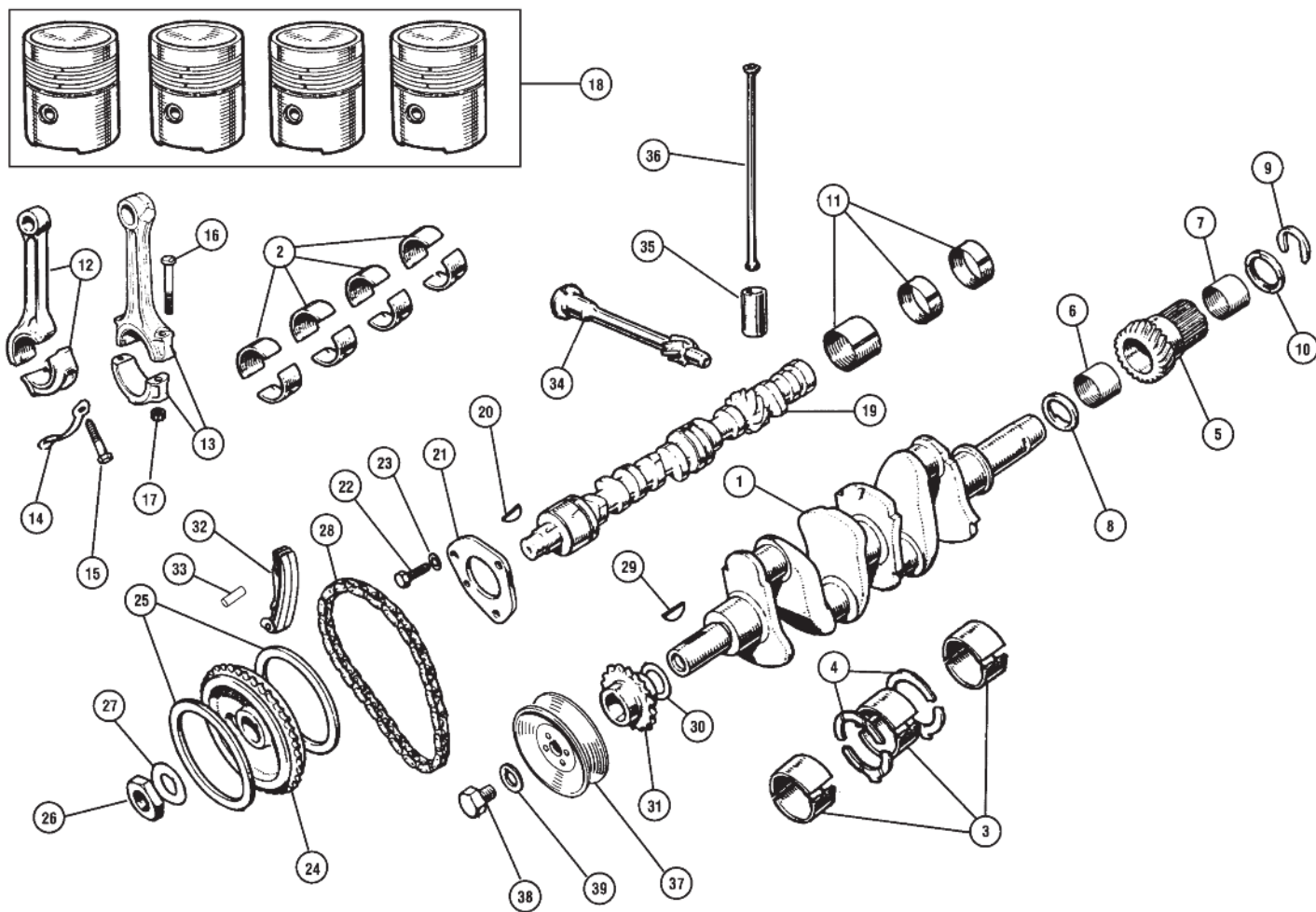

ill. Part Number Price Eea. Description Req. Details

Internal Engine Components (Continued)

					37	CAM6323	£36.00	PULLEY, crank, no damper	1	998cc pre A+
						AHU1878	£117.10	PULLEY, crank, with damper	1	998cc A+ and Cooper 1300cc
	KMD266M	£148.00	CAMSHAFT, fast road, slot drive	1				smooth idle in 1275cc+		
	KMD276M	£133.00	CAMSHAFT, road/rally, slot drive	1				slightly lumpy idle in 1275cc (Very good street cam).		
	KMD286M	£148.00	CAMSHAFT, rally, slot drive (Slot Metro drive).	1				slightly lumpy idle in 1275cc (Max street cam).		
	KMD296M	£148.00	CAMSHAFT, race, slot drive (Slot Metro drive).	1				1380cc+		
	KMD266P	£148.00	CAMSHAFT, fast road, pin drive	1				smooth idle in 1275cc+		
	KMD276P	£148.00	CAMSHAFT, road/rally, pin drive	1				slightly lumpy idle in 1275cc (Very good street cam).		
	KMD286P	£148.00	CAMSHAFT, rally, pin drive	1				slightly lumpy idle in 1275cc (Max street cam).		
	KMD296P	£148.00	CAMSHAFT, race, pin drive	1				1380cc+		
	KMD286SPS	£230.00	CAMSHAFT, scatter, star drive	1				slightly lumpy idle in 1275cc (Max street cam).		
	KMD296SPS	NCA	CAMSHAFT, scatter, star drive	1				1380cc+		
	KMD310SPS	NCA	CAMSHAFT, scatter, star drive	1				lumpy idle in 1380cc		
	KMD286SPM	£190.10	CAMSHAFT, scatter, metro drive	1				slightly lumpy idle in 1275cc (Max street cam).		
	KMD296SPM	£184.00	CAMSHAFT, scatter, metro drive	1				1380cc+		
	KMD310SPM	NCA	CAMSHAFT, scatter, metro drive	1				lumpy idle in 1380cc		
20	WKN505	£1.25	KEY, cam gear locating	1						
	MGS108251	£10.00	KEY, cam gear locating	1				1° offset		
	MGS108252	£12.00	KEY, cam gear locating	1				2° offset		
	MGS108253	£12.00	KEY, cam gear locating	1				3° offset		
	MGS108254	£12.00	KEY, cam gear locating	1				4° offset		
	MGS108255	£10.00	KEY, cam gear locating	1				5° offset		
	MGS108256	£12.00	KEY, cam gear locating	1				6° offset		
	MGS108257	£9.20	KEY, cam gear locating	1				7° offset		
	MGS108258	£9.50	KEY, cam gear locating	1				8° offset		
	MGS108259	£9.00	KEY, cam gear locating	1				9° offset		

(These offset keys make getting the best out of your camshaft easier.
Please see manufacturers data for correct timing figures).

Note: When installing a new camshaft always use a cam lubricant to ensure the cam is protected on 1st start up. We recommend KEN2.

	KEN2	£8.30	CAM LUBE	1				cam assembly lubricant		
21	AHU2379	£10.80	PLATE, camshaft locating	1						
22	GHF117	£0.28	SCREW, plate retaining	3				all 998cc models		
23	GHF321	£0.19	WASHER, locking	3						
24	12G4337	£22.60	GEAR, camshaft	1						
	12G4337	£22.60	GEAR, camshaft	1				998cc A+ and Cooper 1300cc		
	CAJJ3324	£48.00	DUPLEX KIT, cast lightened	1				fast road		
	CAJJ3325	NCA	DUPLEX KIT, steel lightened	1				road/race		
	TMG10828	£117.00	DUPLEX KIT, vernier adjustable	1				Kent Cams kit		
	CAJJ3328	NCA	DUPLEX KIT, adjustable belt	1				toothed belt kit, race		
	BELTBELT	£47.40	BELT, replacement timing belt	1				used with CAJJ3328		
25	8G549	£2.00	RING, tensioner rubber	1				use with 2A85		

Note: Camshaft gear 2A85 is no longer available. If you require a new gear you must purchase the later type 12G4337, although it is possible to replace the rubber damper rings 8G549.

26	6K629	£3.00	NUT, camshaft	1						
27	2A759	£1.32	LOCK TAB, camshaft	1						
28	3H2127	£4.43	TIMING CHAIN, 'Simplex'	1						
	2H4905	£5.62	TIMING CHAIN, 'Duplex'	1						
	2H4905Z	£4.24	TIMING CHAIN, 'Duplex'	1				aftermarket		
	2H4905UR	£30.50	TIMING CHAIN, 'Duplex'	1				high quality		
29	6K836	£5.50	KEY, crank gear	1						
30	6K628	NCA	SHIM, crank gear	a/r						
31	8G725	£13.00	SPROCKET, crankshaft	1						
32	12G2621	£7.00	TENSIONER, timing chain	1				A+		
NI	12G2628	£31.70	TENSIONER PLATE, timing	1				A+		
33	12G2629	NCA	PIN, tensioner pivot	1				A+		
34	12G4499	£48.80	SPINDLE, distributor drive	1				998cc pre A+		
	12G3560	NCA	SPINDLE, distributor drive	1				998cc A+ and Cooper 1300cc		
35	2A13	£2.76	CAM FOLLOWER	8						
	TMG10709	£8.15	CAM FOLLOWER, lightened	8				40 gram with oil drain hole		
36	12A250	£1.66	PUSH ROD	8				850-1100cc		
	2A14	£9.11	PUSH ROD	8				850-1100cc, alternative		
	AE6314	£3.18	PUSH ROD	8				1275cc		

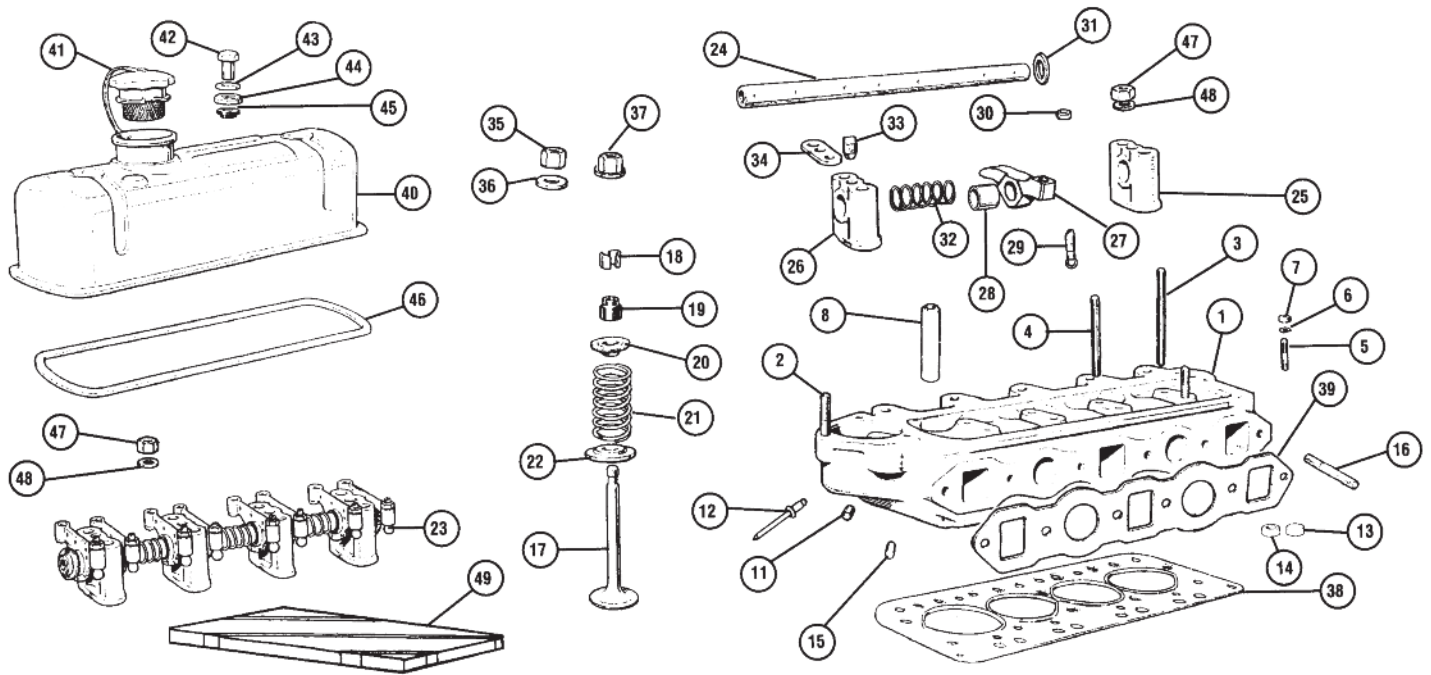

ill.	Part Number	Price £ea.	Description	Req.	Details
Cylinder Head Components					
1	TAM2168	NCA	CYLINDER HEAD, new, bare	1	998cc
	LDF10213	NCA	CYLINDER HEAD, new, bare	1	Cooper 1300cc lead free A+
	451-875	£1,122.00	CYLINDER HEAD, new, bare	1	alloy head casting with improved water jackets
	GCG1001A	NCA	CYLINDER HEAD ASSEMBLY, recon.	1	all 998cc
	GCG1007	£428.00	CYLINDER HEAD ASSEMBLY, recon.	1	all 998cc unleaded
	GCG1009	£428.00	CYLINDER HEAD ASSEMBLY, recon.	1	1275cc unleaded, with bypass
	GCG1009A	£420.00	CYLINDER HEAD ASSEMBLY, exch.	1	1275cc unleaded, no bypass
	TMG10803B	£800.00	CYLINDER HEAD ASSEMBLY, Stage 3	1	1275cc unleaded

ill.	Part Number	Price £ea.	Description	Req.	Details	
	TMG10824B	£850.00	CYLINDER HEAD ASSEMBLY, stage 4	1	1275cc	
	2	CHS2515	£1.36	STUD, thermostat housing	3	998cc models
	3	51K881	£2.05	STUD, thermostat housing	3	Cooper 1300cc
	4	51K885	£2.23	STUD, rocker cover, (long)	2	
	5	51K1473	£1.73	STUD, rocker post, (short)	2	
	6	53K402	£1.50	STUD, heater valve	2	
	7	GHF331	£0.17	WASHER, locking	2	998cc models
	8	GHF200	£0.19	NUT	2	
		TAM1368	NCA	SCREW, heater outlet	2	all models 1989-On
	9	12G1111	£2.95	VALVE GUIDE	8	all models
	10	12G1963	£2.12	VALVE GUIDE, tapered nose	8	all models
	11	TMG10819	£59.40	VALVE GUIDE SET, bronze	1	for use with stainless steel valves
	12	6K808	NCA	PLUG, brass, oil hole	1	998cc pre A+

ill.	Part Number	Price £ea.	Description	Req.	Details
12	RU612123	NCA	RIVET, oil hole	1	998cc A+
	CDU2601	NCA	RIVET, oil hole	1	
13	12G2092	NCA	PLUG, water hole	3	
14	AEA771	£5.05	PLUG, water hole	2	
15	12G3503	£2.20	PLUG, head cleaning	2	
16	FHS2512	£1.50	STUD, manifold	6	all models
	AMS1	NCA	STUD SET, manifold	1	stainless steel

Valve Gear

998cc Models

17	CAM6391	£7.50	VALVE, inlet	4	99H353EH302624
	12G3034	NCA	VALVE, inlet	4	31mm 998cc Cooper and 1098cc
	12A1987	£7.40	VALVE, exhaust	4	99H353EL291101
18	88G459	£1.25	COTTER, valve cap retainer	16	99H353PH824
20	88G616	£2.86	CAP, valve	8	99H503RH19766
21	AEA311	£1.96	VALVE SPRING	8	
22	CAM6520	NCA	SHIM, valve spring	8	99H791P?* To 538152

*Note: Question mark indicates an unknown introduction point. NCA.

17	CAM6502	NCA	VALVE, inlet	4	99H791P538153 On
	CAM6505	NCA	VALVE**, exhaust, lead free	4	99H997P/100/101
	CAM6503	NCA	VALVE, exhaust	4	99H998P/100101
19	ADU4905	£0.80	SEAL, valve guide	8	99HA53P100101 - 110783
18	88G459	£1.25	COTTER	16	99HA941100101 - 100997
20	88G617	£4.96	CAP, valve	8	99HA97100101 - 100427
21	12G1015	£2.59	VALVE SPRING	8	

**Note: Exhaust valve CAM6503 was only fitted on these engines: 99H791P 538153 on, and 99HA97P100101 to 100427.

17	TAM1062	NCA	VALVE, inlet	4	high flow 850cc - 1098cc
	CAEG588	NCA	VALVE, inlet 31.7 mm	4	99HA539P 110784 On
	TAM1770Z	£11.00	VALVE, exhaust	4	high flow 850cc - 1098cc
	CAEG587	NCA	VALVE, exhaust 26.5 mm	4	high flow 850cc - 1098cc
19	ADU4905	£0.80	SEAL, valve guide	8	99HA94P 100998 On
18	CAM6975	£1.70	COTTER, valve cap retainer	16	99HA97P 100428 On
20	AHU1897	£6.35	CAP, valve	8	+ for engine no codes; B83, B84
21	12G1015	£2.59	VALVE SPRING	8	B85, D83
21	AEA311	£1.96	VALVE SPRING	8	E22, G31

Valve Gear

Cooper 1300 Models

17	TAM1058	£8.35	VALVE, inlet	4	33mm lead free
	CAM6669	£5.00	VALVE, inlet	4	35mm
	TAM1061	£15.00	VALVE, exhaust	4	
	TAM1061Z	£9.00	VALVE, exhaust	4	
	CAEG569	£27.50	VALVE, inlet 33.3 mm	4	high flow 1275cc
	CAEG544	£17.00	VALVE, inlet 35.6 mm	4	high flow 1275cc
	CAHT55	NCA	VALVE, inlet 37.2 mm	4	high flow 1275cc
	CAHT110	NCA	VALVE, inlet 37.7 mm	4	high flow 1275cc
	MST2021	£33.30	VALVE, inlet 35.6 mm	4	riflo comp 1275cc
	MST2022	NCA	VALVE, inlet 36.57 mm	4	riflo comp 1275cc
	CAEG106	£16.00	VALVE, exhaust 29.4mm	4	high flow 1275cc
	CAEG107	£18.00	VALVE, exhaust 31.0 mm	4	high flow 1275cc
	MST2011	£30.20	VALVE, exhaust 29 mm	4	riflo comp 1275cc
	MST2012	£31.20	VALVE, exhaust 31 mm	4	riflo comp 1275cc
19	ADU4905	£0.80	SEAL, valve stem	8	
18	CAM6975	£1.70	COTTER	16	
	88G459	£1.25	COTTER	16	high flow valves
20	AHU1897	£6.35	CAP, valve	8	
	TMG10816	£17.30	CAP, valve, alloy	8	
21	12G1015	£2.59	SPRING VALVE	8	
	TMG10807	£39.00	SPRING SET, dual spring set	1	road use
	TMG10808	£131.50	SPRING SET, dual spring set	1	race use

Note: Original rockers are now no longer available, they were either cast (2A533) or pressed steel

ill.	Part Number	Price £ea.	Description	Req.	Details
					(2A964). They can be replaced by either a sintered steel rocker (CAM289) or forged rocker (12G1221). It is advisable to replace in sets due to the difference in weight when compared with the original rocker.
23	12A1950K	£123.19	ROCKER ASSEMBLY, rebuilt	1	
	CAHT436	£170.00	ROCKER ASSEMBLY, high lift	1	1275cc EN16 d/forge 1.5 ratio
	AHT437	NCA	ROCKER ASSEMBLY, roller rockers	1	1275cc 1.3 ratio
	AHT438	£272.40	ROCKER ASSEMBLY, roller rockers	1	1275cc 1.5 ratio
	TMG10848	NCA	ROCKER ASSEMBLY, roller rockers	1	1275cc 1.5 ratio
	AHT440	NCA	ROCKER ASSEMBLY, roller rockers	1	850cc-1098cc 1.5 ratio
24	12A1950	£18.85	ROCKER SHAFT	1	
	12A1950Z	NCA	ROCKER SHAFT	1	aftermarket
	TMG10817	£29.00	ROCKER SHAFT	1	tuftride shaft
25	12G1926	NCA	POST, rocker, with oil feed	3	post nos. 1, 3 and 4
26	12G1927	NCA	POST, rocker, tapped	1	post no 2
27	CAM289	£17.00	ARM, rocker, sintered	8	998cc A+ and Cooper 1300cc
	12G1221	£11.00	ARM, rocker, forged (Must be reamed to suit rocker shaft).	8	not illustrated
28	2A21	£2.05	BUSH, rocker arm	8	
29	12A1215	£5.52	SCREW, adjusting	8	use with 2A964/ 2A533
	12H3376	£1.60	SCREW, adjusting	8	use with 12G1221
	12H3376	£1.60	SCREW, adjusting	8	use with CAM289
30	6K654	£1.46	NUT, adjuster locking	8	use with 2A964/ 2A533
	51K1178	£0.42	NUT, adjuster locking	8	use with 12G1221 and CAM289
31	6K555	£1.20	SPACER WASHER	a/r	
32	6K556	£2.23	SPRING, rocker spacing	3	
	CAEG392	£14.00	SPACER SET ROCKER, solid	1	
33	2A258	£0.90	PEG, rocker shaft locating	1	
34	2A515	NCA	PLATE, rocker shaft peg locating	1	
35	51K1193	£1.20	NUT, cylinder head	9	pre A+ engines
36	12H2178	£0.32	WASHER, flat, hardened	9	
37	51K1193B	£1.85	NUT, cylinder head	9	A+ engines
38	GUG197HG	£11.00	GASKET, cylinder head	1	all 998cc
	GUG702560HG	£18.20	GASKET, cylinder head	1	1275cc and Metro turbo
	AHT188	£20.80	GASKET, cylinder head	1	copper composite competition
	CSTR1057	NCA	GASKET, cylinder head*	1	group A turbo.
*Note this gasket is only for a bore of 1275cc (2.780) +.040 (2.82). This gasket has an extra reinforced fire ring that requires machining the block to the following DATA:					
		Fire ring recess OD in block top	=	3.060	
		Fire ring recess depth in block top	=	0.027/0.029	
39	AJM601	£2.05	GASKET, manifold to cylinder head	1	
	TMG10836	£4.44	GASKET, large bore tubular manifold	1	
40	LDR10074	£48.90	ROCKER COVER	1	pressed steel
	WPA9007X	£38.40	ROCKER COVER, alloy	1	ribbed
	GAC4068P	£26.40	ROCKER COVER, alloy	1	plain
41	GFE6003	£3.30	FILLER CAP	1	
	8G612CP	£7.60	FILLER CAP, chrome	1	for alloy rocker covers
	8G612	£7.20	FILLER CAP, matt steel	1	for alloy rocker covers
42	2A150	£1.36	NUT, rocker cover	2	all 998cc
	2A150CP	£3.20	NUT, CHROME, rocker cover	2	
	12H2557	£3.53	NUT, rocker cover, with stud	2	Cooper 1275cc
	WPA9029X	£9.60	NUT, knurled rocker nuts, pair	1	
43	1B2925	£1.25	SPACER	2	
	CAM6921	£1.55	SPACER CHROME	2	
44	1A2156	£1.00	CUP WASHER	2	
	12G679	£1.15	CUP WASHER CHROME	2	
45	12A1358	£0.46	GROMMET, rocker cover	2	
46	GUG705009VC	£1.32	GASKET, rocker cover	1	
	296-006	£13.70	GASKET, rocker cover, silicone	1	standard cover
	296-007	£16.10	GASKET, rocker cover, silicone	1	alloy cover
	AJM417	£2.40	GASKET, rocker cover, 11 stud head	1	Cooper S notched
47	GHF201	£0.12	NUT, rocker pedestal	4	alternatives
	GHF222	£0.62	NUT, nyloc, rocker pedestal	4	
48	GHF301	£0.22	WASHER, rocker pedestal	4	
49	AJM102	£18.60	GASKET SET, top end	1	998cc pre A+
	AJM102Z	£9.00	GASKET SET, top end, alternative	1	
	GUG701152HS	£31.25	GASKET SET, top end	1	998cc A+
	AJM1140	£25.00	GASKET SET, top end	1	1275cc
	AJM1140Z	£13.80	GASKET SET, top end, alternative	1	
	AJM1238	£7.30	GASKET SET, top end	1	1275CC A+
	GUG1089HS	£15.50	GASKET SET, top end	1	Cooper 1300cc
	AJM1141X	£28.00	GASKET SET, top end	1	1300cc with AF460 gasket
	GUG701113HS	NCA	GASKET SET, top end	1	injection head set

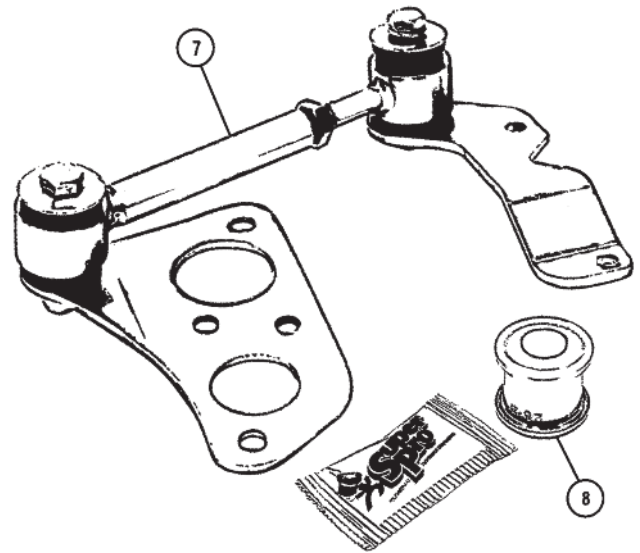
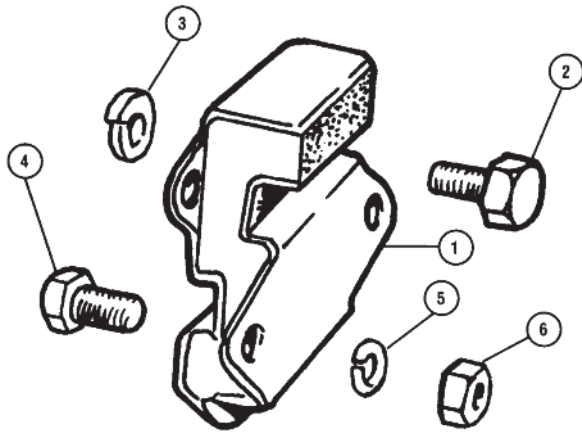

ill.	Part Number	Price Eea.	Description	Req.	Details
Engine Mountings					
1	21A1902	£3.64	ENGINE MOUNT, manual only	2	
	21A1902X	£7.30	ENGINE MOUNT, easy fit	2	captive nuts easy fit
	21A1902P	NCA	ENGINE MOUNT, poly, split	2	two part type
	22A1018	£12.60	ENGINE MOUNT, auto	2	left hand side
	22A917	£45.00	ENGINE MOUNT, auto	1	right hand side
2	SH605051	£0.32	SCREW, fine	3	mount to radiator bracket
	SH505061	£0.60	SCREW, coarse	3	engine mount to fly wheel
3	GHF332	£0.28	WASHER, locking	3	
4	GHF120	£0.28	SCREW, mounting to subframe	4	
5	GHF332	£0.28	WASHER, locking	4	
6	GHF201	£0.12	NUT	4	not required when using 21A1902X

ill.	Part Number	Price Eea.	Description	Req.	Details
Engine Stabiliser					
The ultimate engine steady kit					
A common problem with Minis is their tendency to destroy engine mounts and steady bar bushes, leading to exhaust down pipe breakage. This is the best engine steady kit available. It mounts neatly on the top two bolts of the water pump and on to the bulkhead. It has an adjustable tie rod with rubber bushes, but can be uprated with one piece SuperPro bush. Suitable for all models including LHD cars.					
7	ABR024	£37.80	ENGINE STABILISER KIT	1	
8	CRC5329SP	£4.82	BUSH KIT, steady bar, poly	2	one piece bush

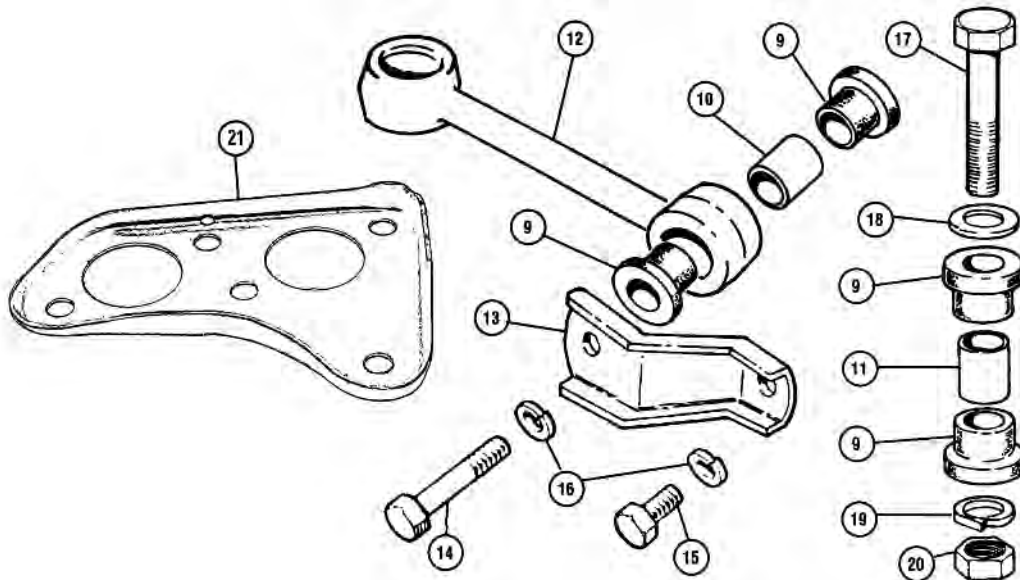

ill.	Part Number	Price Eea.	Description	Req.	Details
Top Engine Stabiliser					
9	CRC5329	£1.70	BUSH, steady bar, rubber	4	standard
	CRC5329SP	£4.82	BUSH KIT, steady bar, poly	2	one piece bush
	C-STR630	NCA	BUSH KIT, steady bar, hard rubber	1	4 x bush, 1 x spacer
10	21A1108	£2.23	SLEEVE, spacer in bush	1	steady bar to block
11	21A1108	£2.23	SLEEVE, spacer in bush	1	steady bar to bulkhead
12	21A1109	£41.30	STEADY BAR	1	
	KAD3283	£67.30	STEADY BAR	1	alloy adjustable
13	21A2387	£20.50	BRACKET, steady bar to block	1	

ill.	Part Number	Price Eea.	Description	Req.	Details
14	BH505181	£1.00	BOLT, long, bracket to block	1	
15	SH505051	£0.62	SCREW, short, bracket to block	1	
16	GHF332	£0.28	WASHER, locking	2	
17	BH605151	£0.79	BOLT, steady bar to bulkhead	1	
18	GHF302	£0.60	WASHER, plain	1	
19	GHF333	£0.28	WASHER, locking	1	
20	GHF201	£0.12	NUT	1	
21	14A6733	£13.00	BRACKET, engine stabiliser	1	fits under brake & clutch master cylinder

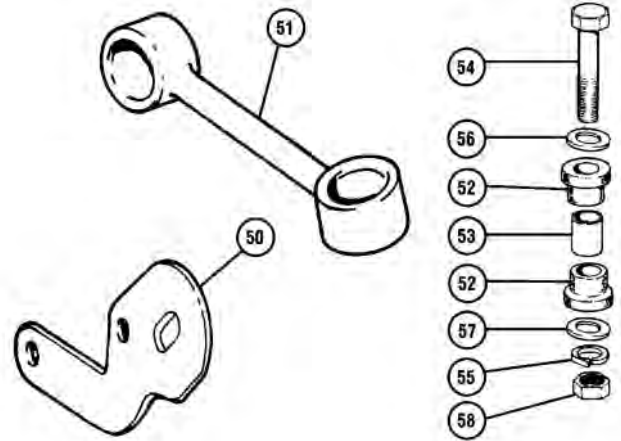
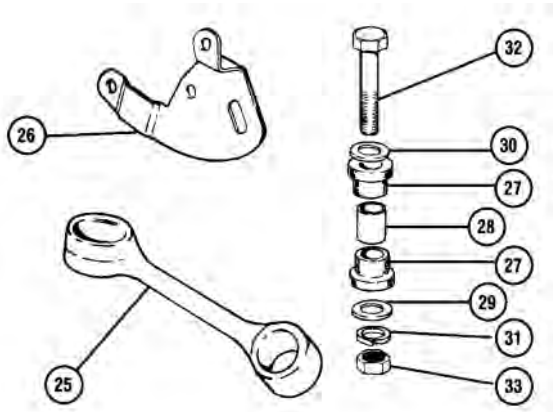

ill.	Part Number	Price £ea.	Description	Req.	Details
Lower Near Side Rear Stabiliser					
25	21A2569	£18.40	STEADY BAR	1	
26	21A2763	£5.20	BRACKET, gearbox	1	
27	CRC5329	£1.70	BUSH, steady bar*	4	
28	31G1085	£2.59	SLEEVE, spacer in bush*	2	
29	GHF302	£0.60	WASHER, plain	2	
30	PWZ306	£0.42	WASHER, plain*	2	
31	GHF333	£0.28	WASHER, locking*	2	
32	BH606181	£1.36	BOLT*	2	} steady bar to bracket and sub-frame
33	GHF202	£0.19	NUT*	2	

ill.	Part Number	Price £ea.	Description	Req.	Details
Lower Off Side Front Stabiliser					
50	KKU10080	£9.00	BRACKET, on clutch housing	1	998cc
	KKU10080	£9.00	BRACKET, on clutch housing	1	1275cc
51	FAM2758	£23.00	STEADY BAR	1	1990-On
52	CRC5329	£1.70	BUSH, steady bar*	4	
53	31G1085	£2.59	SLEEVE, spacer in bush*	2	
54	BH606181	£1.36	BOLT*	2	} steady bar to bracket and sub-frame
55	GHF333	£0.28	WASHER, locking*	2	
56	PWZ306	£0.42	WASHER, large	1	
57	GHF302	£0.60	WASHER, plain	1	
58	GHF202	£0.19	NUT*	2	

*Note: These items are the same for both ends of the steady bar.

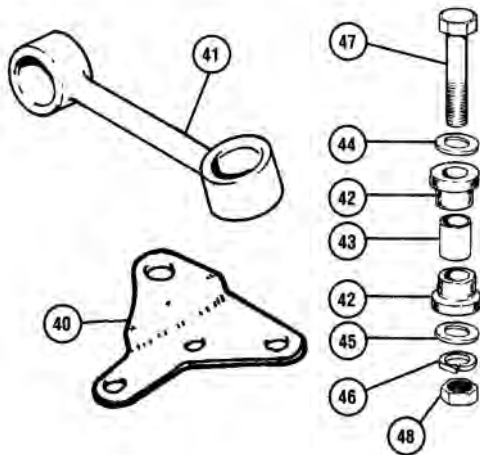

ill.	Part Number	Price £ea.	Description	Req.	Details
Lower Off Side Rear Stabiliser					
40	21A2785	£6.00	BRACKET, on clutch housing	1	
41	21A2787	£22.60	STEADY BAR	1	
	21A2787K	£42.80	STEADY BAR KIT	1	
42	CRC5329	£1.70	BUSH, steady bar*	4	
43	31G1085	£2.59	SLEEVE, spacer in bush*	2	
44	PWZ306	£0.42	WASHER, large, plain*	3	
45	GHF302	£0.60	WASHER, plain*	2	
46	GHF333	£0.28	WASHER, locking*	2	
47	BH606181	£1.36	BOLT*	2	} steady bar to bracket and sub-frame
48	GHF202	£0.19	NUT, Nyloc*	2	

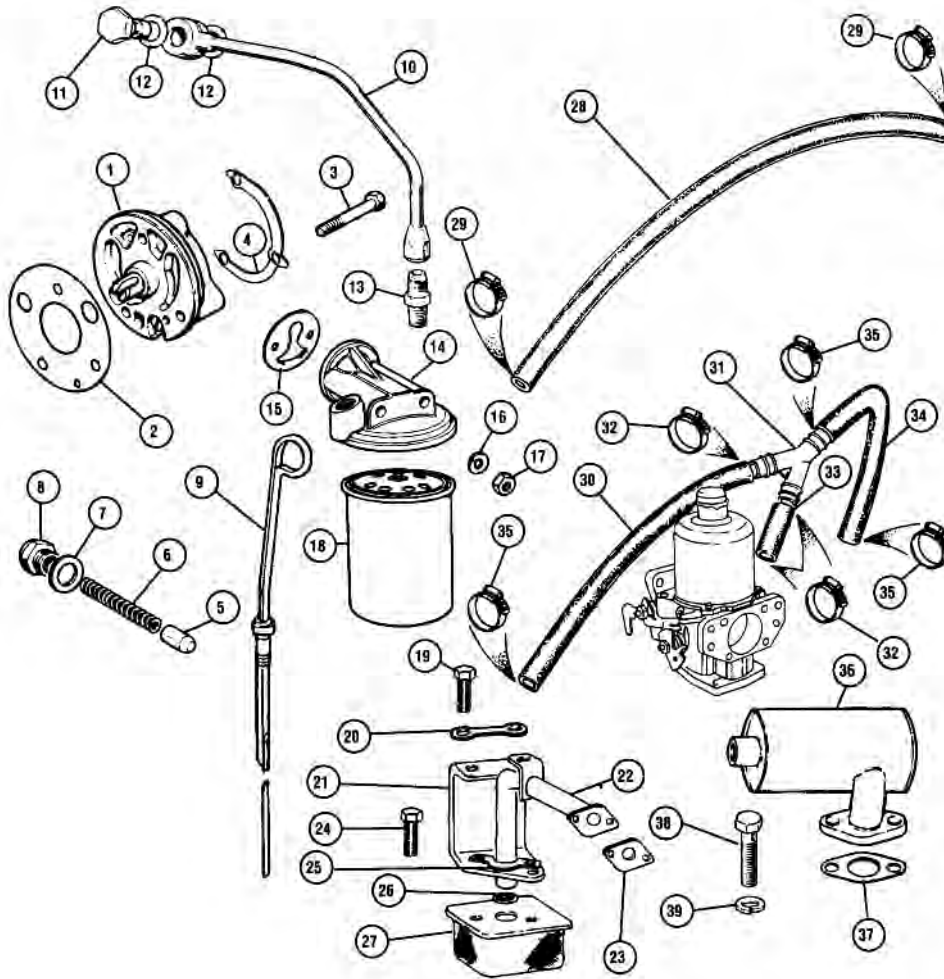

ill.	Part Number	Price £ea.	Description	Req.	Details
Oil Control					
1	GLP142	£19.00	OIL PUMP, pin drive	1	850-1098cc pre A+
	GLP141	£23.00	OIL PUMP, star drive	1	1275cc pre A+
	GLP139	£23.10	OIL PUMP, slot drive	1	998cc A+
	GLP138	£17.40	OIL PUMP, slot drive	1	1275cc A+
	GLP110	£41.20	OIL PUMP, slot drive	1	turbo
2	GUG705560GM	£0.79	GASKET, oil pump	1	
3	BH604141	£1.04	BOLT, oil pump	3	998cc
	TAM1174	NCA	BOLT, oil pump	4	1275cc A+
4	12G926	£1.96	LOCK WASHER, pin drive pumps	1	
5	12H865	£4.24	VALVE, oil release	1	
	12H865X	£0.70	VALVE BALL, oil release	1	no more sticking valves
6	6K853	£1.20	SPRING, oil valve	1	
	6K853C	£1.20	SPRING, oil valve	1	use with 12H865X
7	6K431B	£0.73	WASHER, copper	1	
8	12A1851	£4.50	CAP, oil pressure release valve	1	
9	12A116	NCA	DIPSTICK	1	pre A+
	LQM100380	£20.30	DIPSTICK	1	A+ without tube
	GAC8457X	£10.80	DIPSTICK, blue	1	A+
	GAC8458X	£10.80	DIPSTICK, red	1	A+
10	TAM2106	NCA	OIL PIPE, block to filter	1	Cooper, no oil cooler
	MT1501	£62.70	OIL PIPE, block to filter, braided	1	12a 1990-On
	MT9101	NCA	OIL PIPE, turbo oil feed	2	braided oil feed pipe
	OCHK100	£25.60	OIL PIPE KIT, rubber	1	oil cooler pipe kit To 1979
	OCHK102	£45.30	OIL PIPE KIT, stainless steel	1	oil cooler pipe kit To 1979
	OCHK103	£15.00	OIL PIPE KIT, rubber	1	oil cooler pipe kit 1979-84
	OCHK104	£72.50	OIL PIPE KIT, stainless steel	1	oil cooler pipe kit 1979-84

ill.	Part Number	Price £ea.	Description	Req.	Details
	OCHK105	£50.70	OIL PIPE KIT, rubber	1	oil cooler pipe kit 1985-On
	OCHK106	£60.60	OIL PIPE KIT, stainless steel	1	oil cooler pipe kit 1985-On
	OCHK101	£42.00	OIL PIPE KIT	1	oil cooler pipe kit Clubman
11	2A715	£21.10	BANJO BOLT, oil pipe to block	1	
12	AED172	£1.15	WASHER, sealing	2	
	LZB10017	£4.18	OLIVE SEAL	2	collapsible olive seal (For standard metal injection oil feed pipe).
13	TAM2119	NCA	ADAPTOR, oil pipe to housing	1	
14	TAM2097	£22.60	HOUSING, filter head	1	
15	GUG705553GM	£1.80	GASKET, filter housing to block	1	
16	GHF333	£0.28	WASHER, locking	2	
17	GHF202	£0.19	NUT	2	
18	8G684	£8.30	OIL FILTER, felt element	1	early
	GFE103	£3.58	OIL FILTER, paper element	1	
	GFE104	£4.24	OIL FILTER, paper element	1	auto
	GFE166	£2.76	OIL FILTER, canister	1	all models
	LPW100180	£3.68	OIL FILTER, canister	1	mpi 1996-On
19	GHF101	£0.28	SCREW, bracket to gearbox case	2	
20	22A1365	NCA	LOCK TAB	1	
21	22A343	NCA	BRACKET, oil pipe support	1	
22	22G1150	NCA	PIPE, oil suction	1	
	CAHT54	£30.00	PIPE, oil suction	1	(Central pick up required too ensure constant oil delivery under heavy cornering).
23	22A542B	£1.66	GASKET, pipe to gearbox case	1	
24	SH604031	£1.04	SCREW, strainer to bracket	2	
25	22A388	NCA	LOCK TAB	1	
26	22A341	NCA	'O' RING	1	
27	22A335	NCA	STRAINER, oil suction	1	

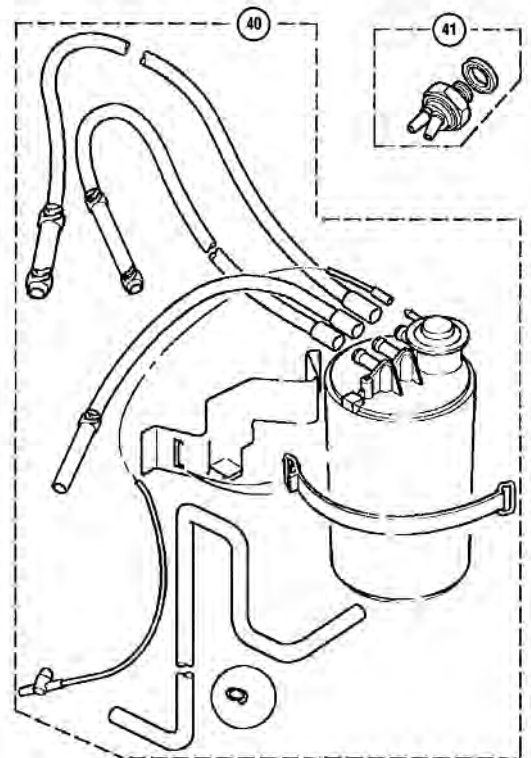
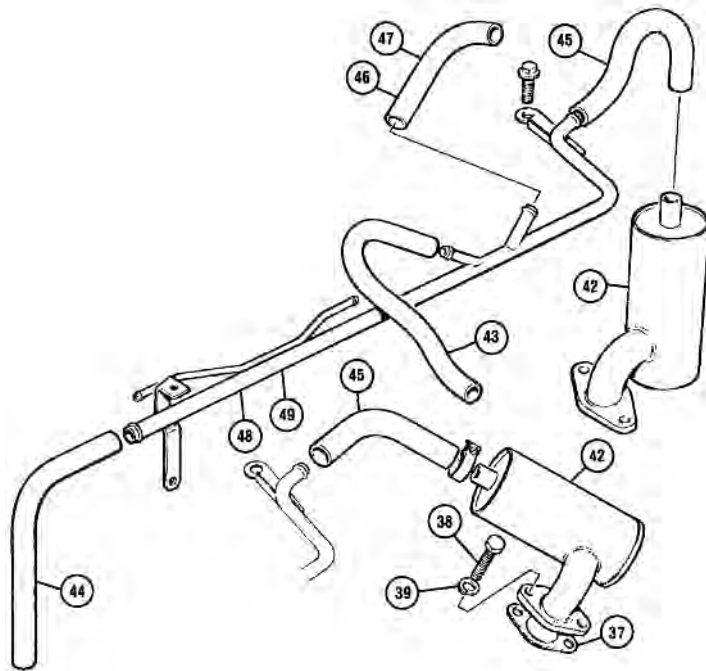
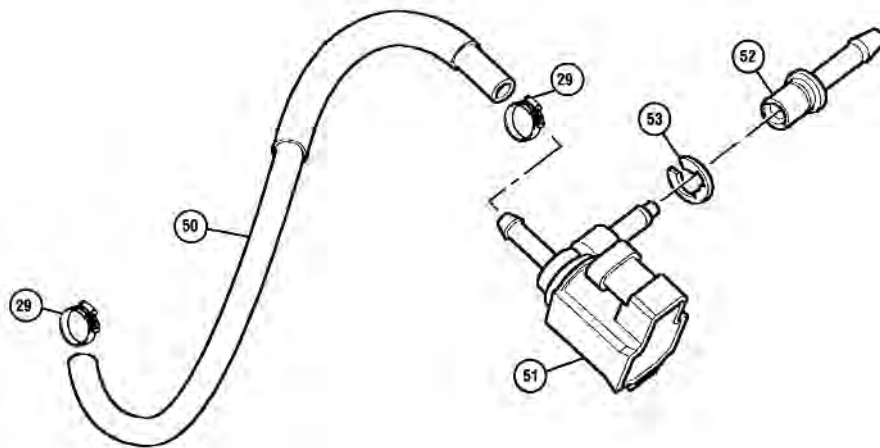

ill.	Part Number	Price £ea.	Description	Req.	Details
Breather Hose & Fittings					
998cc Models					
28	12A1735	£6.85	HOSE, breather, tappet	1	chest to carburettor
29	GHC11022	£2.05	CLIP, large, hose	1	to tappet chest
	GHC11020	£1.96	CLIP, small, hose	1	to carb
Cooper 1275cc and SE Models					
30	12A1735	£6.85	HOSE, breather	1	timing cover to 'Y' piece
31	12G2134	£2.90	'Y' PIECE	1	
32	GHC11020	£1.96	CLIP, hose	3	
33	LLH10056	£2.42	HOSE, breather	1	'Y' piece to carb.
34	LLH10057	NCA	HOSE, breather	1	'Y' piece to oil separator
35	GHC11022	£2.05	HOSE CLIP	1	
36	LLC10047	£36.20	OIL SEPARATOR	1	flywheel housing
37	GUG705551GM	NCA	GASKET, oil separator	1	
38	SH505061	£0.60	SCREW, oil separator	1	to flywheel housing
39	GHF332	£0.28	WASHER, locking	2	
	GHF201	£0.12	NUT	1	
	53K2171	£1.25	STUD, separator on housing	1	
40	WTB100760	NCA	CANISTER CHARCOAL (Supplied with bracket assembly).	1	carburettor models
41	MAQ10008	NCA	SWITCH, carburettor vacuum	1	thermostatic control
41a	ADU9535	£76.70	VALVE, anti run on	1	1275cc Cooper 1990-91

ill.	Part Number	Price £ea.	Description	Req.	Details
	UAM1600	£5.30	T PIECE, servo hose to valve	1	1275cc Cooper 1990-91
	GRH1006M	£6.14	HOSE, servo to valve 1m length	1	
Injection Models					
42	LLC10051	NCA	OIL SEPARATOR	1	auto and mpi
43	LLH10082	NCA	HOSE, breather	1	metal rail to throttle body
44	LLH10132	£4.75	HOSE, breather	1	metal rail to timing cover
45	LLH10135	NCA	HOSE, breather	1	metal rail to clutch cover
46	LLH102240	NCA	HOSE, breather	1	metal rail to throttle body top inlet mpi
47	LLH101830	NCA	HOSE, breather	1	metal rail to throttle body top inlet spi
48	LLP10026	NCA	PIPE, metal (Metal supply pipe to hoses runs behind rocker cover box spi).	1	
49	LLP100300	NCA	PIPE, metal (Metal supply pipe to hoses runs behind rocker cover box mpi).	1	
50	MAH10035	£9.10	HOSE	1	hose to purge valve
51	AUU1503	NCA	PURGE VALVE	1	
52	JZV1223	NCA	TUBE PLASTIC, purge valve	1	
53	JZV1224	NCA	CLIP, purge valve tube	1	

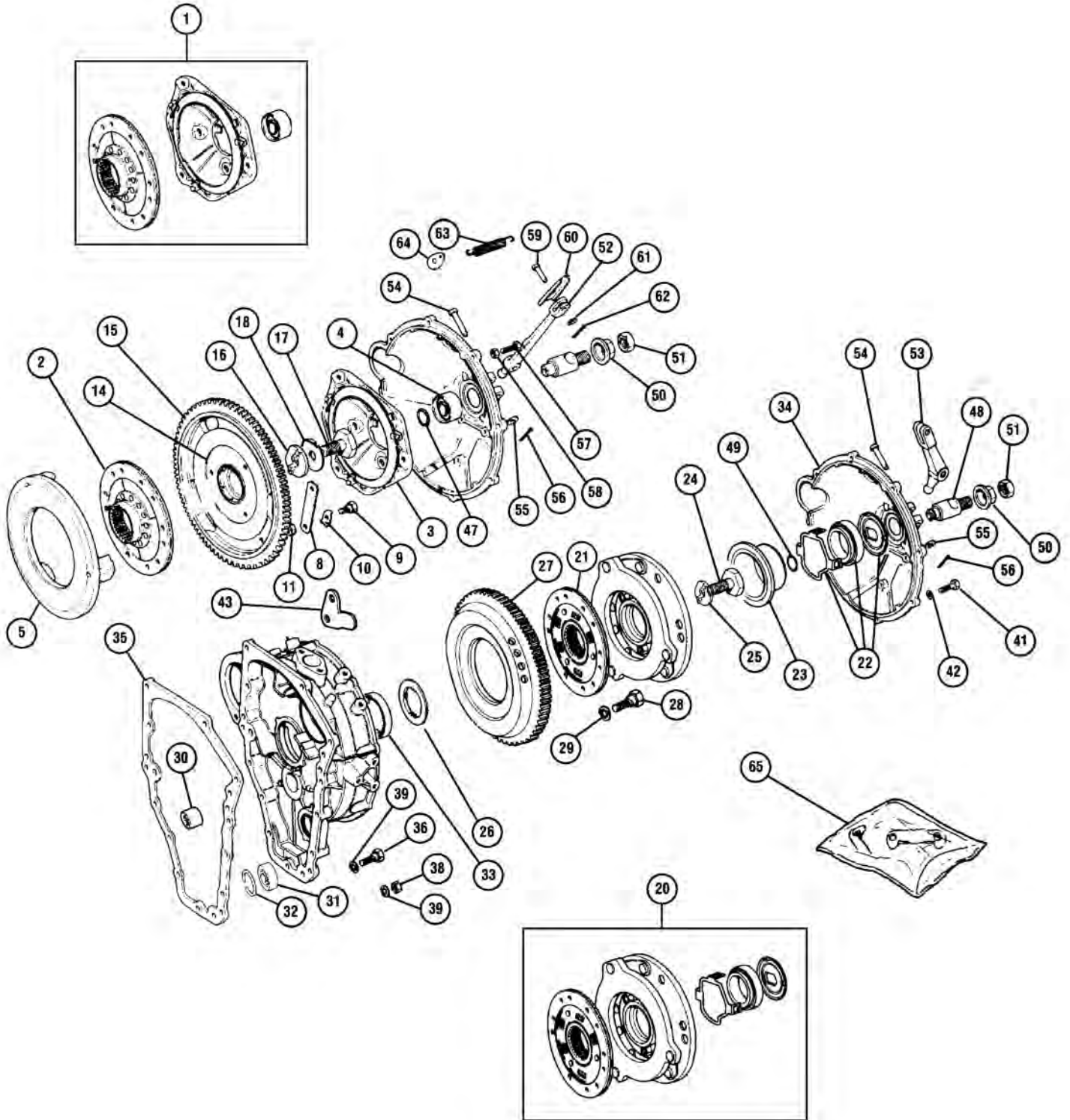

Ill.	Part Number	Price £ea.	Description	Req.	Details
Diaphragm Clutches					
1	GCK100AF	£49.00	CLUTCH ASSEMBLY	1	contains items 2, 3 and 4
2	GCP204AF	£31.00	CLUTCH PLATE	1	
	GCP204BB	£57.60	CLUTCH PLATE, B&B	1	aftermarket
	GCP596	£131.00	CLUTCH PLATE, road rally	1	
3	GCC103	£48.00	CLUTCH COVER, (diaphragm)	1	
	GCC103BB	£40.80	CLUTCH COVER, B&B	1	aftermarket
	GCC481	£39.00	CLUTCH COVER, road rally	1	
	GCC482	£37.80	CLUTCH COVER, rally race	1	
4	GRB238	£8.00	RELEASE BEARING	1	
5	22A598	£100.00	PRESSURE PLATE	1	
	CAHT230	£100.00	PRESSURE PLATE	1	lightweight 3.56lbs
6	2A3657	£2.80	SCREW	3	diaphragm to plate
7	GHF323	£0.19	WASHER, shake-proof	3	
8	2A3658	£7.40	STRAP, driving	6	road use or 9 for race/rally
9	2A3659	£2.38	SCREW, strap to flywheel	3	
10	2A3512	NCA	LOCKTAB, for above	3	
11	GHF302	£0.60	WASHER	3	
14	12G3014	NCA	FLYWHEEL	1	
	CAEG619	£165.00	FLYWHEEL, steel (For 107 tooth ring gear with inertia starter motor).	1	super light 8.38lbs
	CAEG620	NCA	FLYWHEEL, steel (For 129 tooth ring gear with pre-engaged starter motor).	1	super light 8.38lbs
	CAEG420	£165.00	FLYWHEEL, steel (For 129 tooth ring gear with pre-engaged starter motor).	1	light weight 11lbs
15	12G676	£27.80	RING GEAR (Standard manual transmission 107 tooth).	1	wide type
	22G2613	£26.00	RING GEAR (As used on race fly wheels 107 tooth).	1	thin type
16	88G508	£9.00	KEY, flywheel to crankshaft	1	
17	22A747	£8.40	BOLT, flywheel	1	
18	22A1155	£2.90	LOCKTAB, flywheel bolt	1	

Verto Clutches

Note: Verto manufactured clutches were first used on the Metro range in 1983, to counter problems with clutch judder and reliability. They were built as an assembly and dynamically balanced to reduce these problems.

Although it is possible to purchase component parts, we only offer the assembly as it promises less maintenance and reduces the risk of a juddering clutch.

20	GCK149AF	£142.00	CLUTCH ASSEMBLY, inertia starter (180mm centre plate, diaphragm and release bearing).	1	998cc
	GCK2123AF	£150.70	CLUTCH ASSY, pre-engaged starter (190mm centre plate, diaphragm and release bearing).	1	1275cc
	GCU90122AF	NCA	CLUTCH ASSEMBLY	1	Cooper 1275cc and SE
21	GCP90311AF	£50.00	CLUTCH PLATE, verto	1	998cc
	GCP90832AF	£53.00	CLUTCH PLATE, verto	1	1275cc
	GCP596	£131.00	CLUTCH PLATE, road/rally	1	
22	GRB239	£6.55	RELEASE BEARING	1	
23	AHU1564	£35.90	THRUST SLEEVE	1	
24	DAM5922	£10.00	BOLT, with lock-washer	1	
25	DAM5923	£14.00	KEY, crankshaft to fly wheel	1	
26	DAM2821	NCA	DUSTSHIELD, primary gear seal	1	
27	12G2445	NCA	RING GEAR, 107 teeth	1	inertia starter
	PSF10003	£27.50	RING GEAR, 129 teeth (Verto or pre-Verto fly wheel with pre-engaged starter).	1	pre-engaged starter
28	BAU2319	£0.86	BOLT, cover fixing	6	
29	GHF323	£0.19	WASHER, cover fixing	6	
30	88G302	£5.30	BEARING, idler gear (1.004" ext. dia.)	1	1959-68, 3 synchro gearbox
	13H7848	£6.60	BEARING, idler gear (1.065" ext. dia., 0.750" int. dia.)	1	1968-79, 4 synchro gearbox
	AHU1707	£14.40	BEARING, idler gear (1.375" ext. dia., 0.875" int. dia.)	1	1979 on, 4 synchro gearbox
	DAM3745	£18.60	BEARING, idler gear with sleeve (1.375" ext. dia., 0.750" int. dia.)	1	Pre A+ inner diameter with A+ outer diameter.

Note: For 3 synchro gearbox models (1959-68) none of the 4 synchro flywheel housings can be used. When fitting an A series idler gear to A+ housing, use DAM3745 which has a special sleeve. DAM3745 has a pre A+ inner diameter and A+ outer diameter, meaning you can use the larger A+ housing with a smaller pre A+ idler gear.

If you are unsure what is original for your car, you can check the size required by measuring the bearing location in the flywheel housing (to get the external diameter for the idler bearing) and measure the idler gear shaft diameter (to get the internal diameter required). This should give you the size of bearing required to suit your needs.

31	AAU8424	£15.20	BEARING, 1st motion shaft spigot	1	
32	2A3643	£4.20	SPRING RING, for bearing	1	

Ill.	Part Number	Price £ea.	Description	Req.	Details
33	13H2934	£3.18	OIL SEAL	1	
	LUF10005	£6.79	OIL SEAL, improved seal	1	standard 1991-On
34	AHU1106	NCA	COVER, with timing hole	1	
35	22A2237B	£3.30	GASKET, housing to transmission	1	
36	BH605141	£1.04	SCREW, housing to block	3	long
	DAM7758	NCA	BOLT, flanged, housing to block	3	long
	GHF103	£0.54	SCREW, housing to block	3	short
38	FN2505	£0.68	NUT, housing, stud from gearbox	9	
39	GHF332	£0.28	WASHER, locking	9	
41	DAM7755	£0.79	SCREW, cover to housing	7	
42	GHF301	£0.22	WASHER, plain	1	
	GHF332	£0.28	WASHER, spring	1	use with DAM7755
43	22A1299	NCA	PLATE, dowel retaining	1	
46	22A180	£7.30	PLUNGER, clutch	1	press fit To 1979
	DAM1955	£35.00	PLUNGER, clutch	1	floating fit 1979-84
47	DAM2413	£2.63	RING, locking, plunger to bearing	1	

Note: Always renew DAM2413 when replacing release bearing.

48	DAM5353	NCA	PLUNGER	1	Verto clutches
	DAM5353Z	£16.94	PLUNGER, aftermarket	1	
49	AAU2866	£2.30	'O' RING, plunger to bearing	1	use with DAM5353
50	22A427	£6.00	STOP, plunger	1	
51	NT610041	£0.84	NUT, plunger stop locking	1	
52	22A2204	£26.00	LEVER, clutch release, long	1	diaphragm clutches
53	DAM5355Z	£18.30	LEVER, clutch release, short	1	Verto clutches
54	CLZ628	£1.86	CLEVIS PIN, clutch pivot	1	
55	GHF302	£0.60	WASHER	1	
56	GHF502	£0.19	SPLIT PIN	1	For CLZ628
57	GHF101	£0.28	SCREW, clutch lever stop	1	
58	JN2107	£0.28	LOCKNUT	1	
59	CLZ518	£1.55	CLEVIS PIN	1	
60	2A3601	£4.40	SPRING PLATE, lever end	1	
61	GHF301	£0.22	WASHER	1	
62	GHF502	£0.19	SPLIT PIN	1	
63	1G5999	£1.92	SPRING, clutch arm return	1	
64	2A3600	NCA	SPRING PLATE, slave cylinder end	1	
65	18G8086	NCA	LOCK TAB SET	1	

(This set contains all lock tabs required for re-assembly of the flywheel housing, on later cars shouldered bolts are used instead of studs, these replace the lock tabs as they are self locking).

Note: Whenever work has been carried out on the clutch assembly or the flywheel has been removed, its good practice to have the assembly balanced again before it's reinstalled. This will help achieve a smoother running engine. An out of balance flywheel can cause a great deal of damage and shorten the life of the engine.

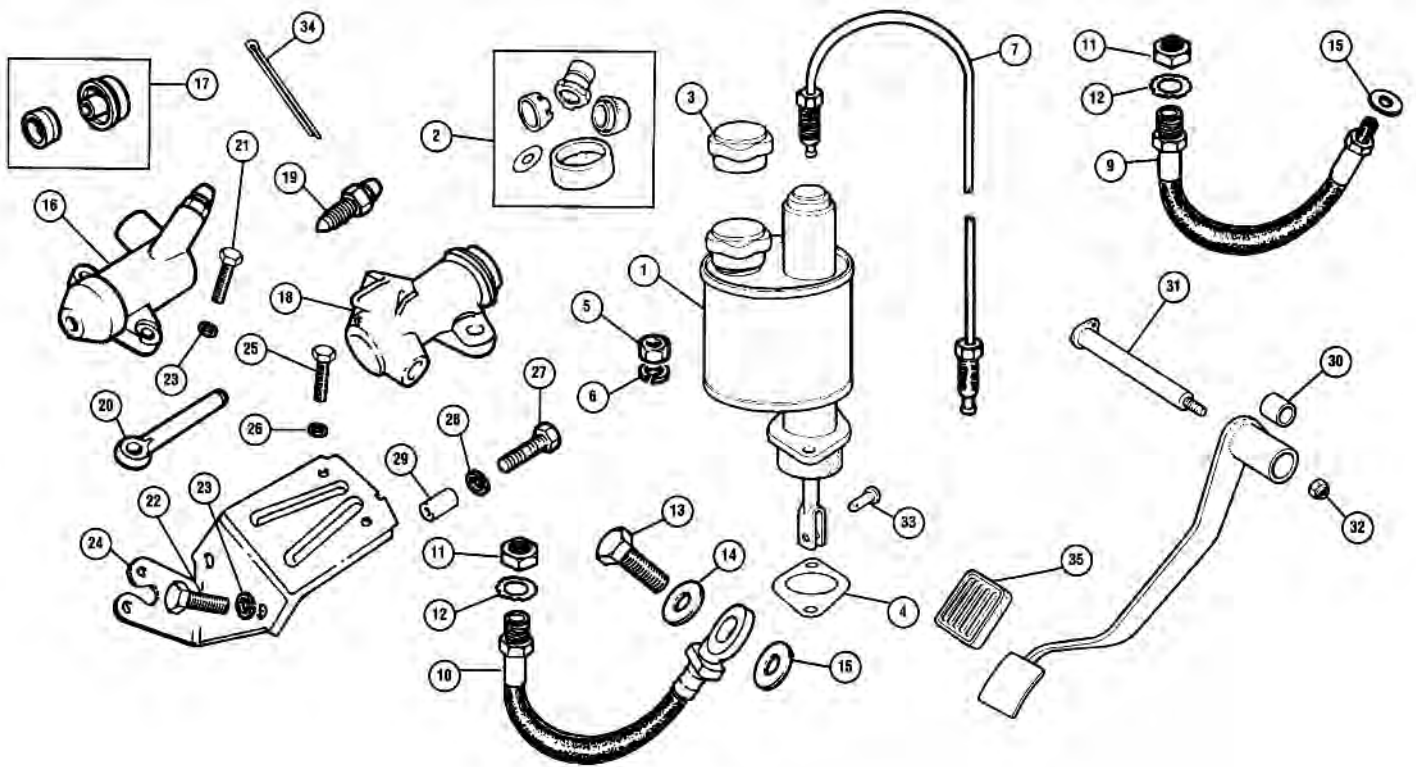

ill. Part Number Price Eea. Description Req. Details

Clutch Hydraulics & Pedal

1	GMC1008	£47.00	MASTER CYLINDER, clutch, plastic	1	
	AAU4969	£71.00	MASTER CYLINDER, clutch, metal body	1	original
2	GRK3007	£12.00	SEAL KIT, 1 ring seal, 1 cap seal	1	early spec, To 1985
	GRK3007Z	£4.40	SEAL KIT, 1 ring seal, 1 cap seal	1	early spec, alternative, To 1985
	GRK3004Z	£5.00	SEAL KIT, 2 ring seals	1	late spec, 1985-On
3	513123A	£4.00	CAP, fluid reservoir	1	
4	31G279	£1.96	WASHER, under master cylinder	1	
5	FNZ505	£0.68	NUT, master cylinder to bracket	2	
6	GHF332	£0.28	WASHER, locking	2	
7	GPP12AA	£11.75	PIPE, master cylinder to hose	1	RHD
	GPP32AA	£13.66	PIPE, master cylinder to hose	1	LHD
9	GVP1020	£8.10	HOSE, pipe to slave cylinder	1	diaphragm clutches
	21A2234Z	£10.75	HOSE, pipe to slave cylinder	1	To 1980
	MT2401	£24.80	HOSE, pipe to slave cylinder (From master cylinder to slave cylinder)	1	stainless steel braided
	GAC8446X	NCA	HOSE, pipe to slave cylinder (Diaphragm clutches).	1	eliminates use of solid intermediate pipe, diaphragm clutches. To 1983 stainless steel braided
10	GVP1009	£12.70	HOSE, pipe to slave cylinder	1	Verto clutches
	GAC8447X	£14.50	HOSE, pipe to slave cylinder (Banjo end, Verto clutches).	1	1983-On stainless steel braided
	MT2401	£24.80	HOSE, pipe to slave cylinder (From master cylinder to slave cylinder, Banjo both ends, Verto clutches).	1	1983-On stainless steel braided
11	2K8686	£1.20	NUT, pipe to bulkhead	1	
12	WE600101	£0.42	WASHER, locking	1	
13	C5192A	£5.40	BOLT, banjo, hose to cylinder	1	Verto clutches
14	3H550	£0.60	WASHER, copper, large	1	
15	233220A	£0.84	WASHER, copper, small	1	
16	GSY110	£28.00	SLAVE CYLINDER	1	diaphragm clutches
17	GRK4008	£6.90	SEAL KIT	1	hose screw into body
	GRK4008Z	£2.63	SEAL KIT, aftermarket	1	
18	GSY118	£40.80	SLAVE CYLINDER	1	Verto clutches
17	GRK4001	£6.00	SEAL KIT	1	
	GRK4001Z	£4.27	SEAL KIT, aftermarket	1	banjo holds hose to body
19	3H2428	£0.95	BLEED NIPPLE	1	
20	13H396	£6.40	PUSH ROD	1	

Note: For clevis pin and fittings please see General Hardware at the back of this catalogue.

21	SH506101	£0.94	SCREW, slave cylinder to housing	2	To fit GSY110
22	GHF105	£0.37	SCREW, slave cylinder to plate	2	To fit GSY118
23	GHF333	£0.28	WASHER, locking	2	
24	DAM5992	£22.90	PLATE, slave cylinder	1	
25	GHF165	£0.37	SCREW, plate to housing	2	
26	GHF333	£0.28	WASHER, locking	2	
27	SH604141	£0.62	BOLT, plate to housing via spacer	1	use with GSY118
28	GHF331	£0.17	WASHER, spring	1	
29	17H2518	£2.95	SPACER	1	alternative CTF
30	2A3034	£5.70	BUSH, in pedal	2	for brake & clutch
31	2A5880	£36.00	PIVOT PIN	1	
32	GHF222	£0.62	NUT, nyloc	1	
33	CLZ512	£1.52	CLEVIS PIN, pedal to master cylinder	2	
34	GHF503	£0.28	SPLIT PIN	2	
35	GPR104A	£0.95	RUBBER, brake & clutch pedal	2	To 1976
	GPR107A	£1.20	RUBBER, brake & clutch pedal	2	1976-90
	SZU10001	£5.50	RUBBER, brake & clutch pedal	2	1990-On



36	GBF4102	£6.50	BRAKE/CLUTCH FLUID, DOT4	a/r	500ml
	GBF4103	£11.65	BRAKE/CLUTCH FLUID, DOT4	a/r	1 litre
	GBF4104	£46.80	BRAKE/CLUTCH FLUID, DOT4	a/r	5 litre
37	GBF5102	£8.10	BRAKE/CLUTCH FLUID, DOT5.1	a/r	racing 500ml
	GBF5103	£15.14	BRAKE/CLUTCH FLUID, DOT5.1	a/r	racing 1 litre

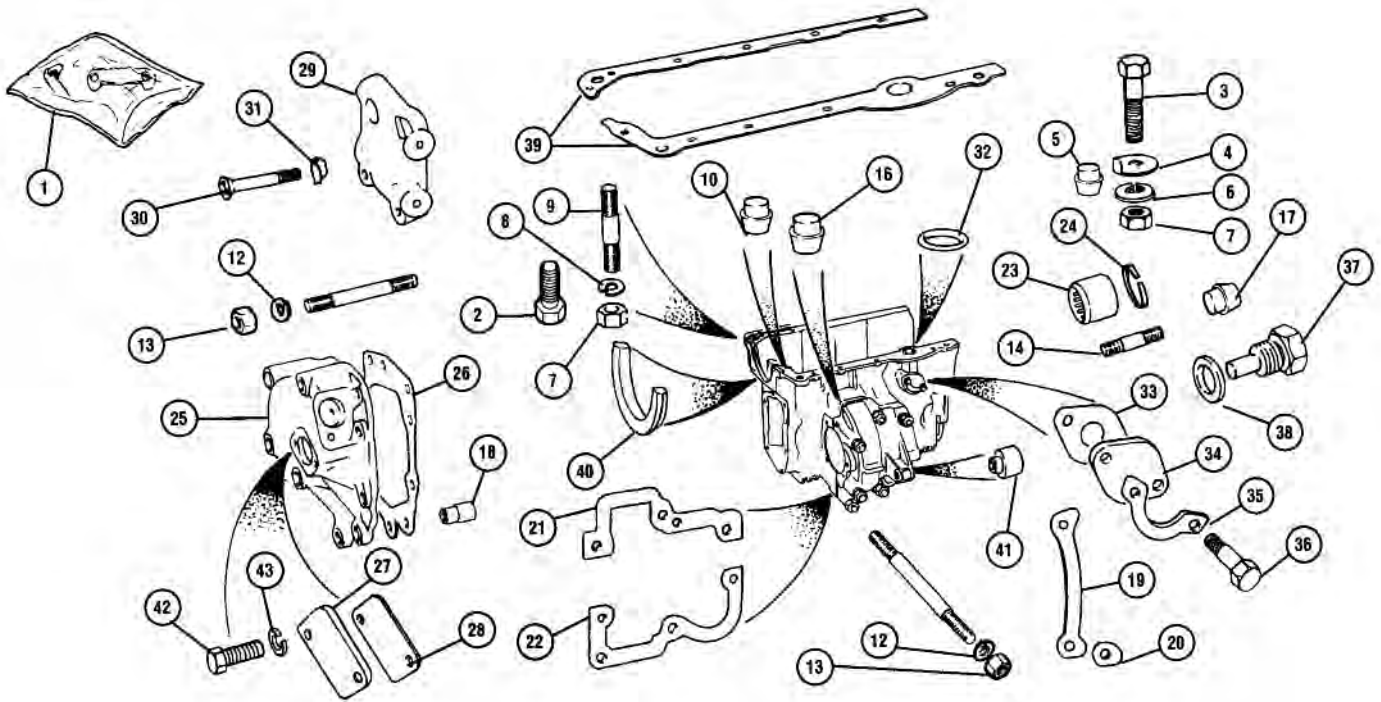

ill.	Part Number	Price £ea.	Description	Req.	Details
Gearbox Externals					
1	18G8085	NCA	KIT, gearbox lock tabs	1	
2	GHF102	£0.42	BOLT, long, block to gearbox	5	
	GHF101	£0.28	SCREW, short, block to gearbox	5	
3	BH604141	£1.04	BOLT, rear dowel	1	
4	12A1150	NCA	COLLAR, rear of block	1	
5	22H983	NCA	DOWEL, hollow block to gearbox	1	rear
6	GHF300	£0.19	WASHER, locking	1	
7	GHF200	£0.19	NUT, plain, block to gearbox	1	
8	GHF331	£0.17	WASHER, spring 1/4"	13	
9	FHS2410	£1.10	STUD, thin flange block	2	A+ models
10	12H1824	NCA	DOWEL, block to gearbox	1	front
11	TAM1617	£7.00	STUD, long	4/2	
	22G1834	NCA	STUD, short	2	
12	GHF332	£0.28	WASHER, locking	6	
13	FNZ506	£0.62	NUT, diff housing stud 3/8" UNF	4	
	FNZ505	£0.68	NUT, diff housing stud+front cover	6	5/16" UNF
14	22A152	£3.00	STUD, flywheel housing, long	6	
	53K547	£1.20	STUD, flywheel housing, short	3	
16	22A153	NCA	DOWEL, diff housing	2	
17	22A97	NCA	DOWEL, flywheel housing	2	
18	22A13	NCA	DOWEL, speedo drive housing	2	
19	42H500	NCA	LOCKTAB, diff housing	1	
20	22A251	NCA	LOCKTAB, diff housing	1	
21	2A3505B	£0.37	GASKET, upper, diff housing	1	
22	2A3506B	£1.45	GASKET, lower, diff housing	1	pre rod change
	22G1836B	£0.54	GASKET, lower, diff housing	1	rod change
	GGL1009	£14.04	RTV BLACK SILICONE COMPOUND	1	
			(Rover now use silicone in place of these gaskets for upper and lower differential housing).		
23	13H7848	£6.60	BEARING, idler gear	1	(1.065" O/D, 0.750" I/D)

ill.	Part Number	Price £ea.	Description	Req.	Details
	DAM3745	£18.60	BEARING, idler gear	1	(1.375" O/D, 0.750" I/D)
	AHU1707	£14.40	BEARING, idler gear	1	(1.375" O/D, 0.875" I/D)
24	51K3565	£0.29	CIRCLIP, (when 13H7848 fitted)	1	
25	DAM5219	NCA	COVER, speedo drive housing	1	
26	22A541B	£1.00	GASKET, drive housing	1	
27	2A3626	NCA	PLATE, speedo drive housing	1	
28	GUG705564GM	NCA	GASKET, speedo drive case plate	1	
29	12G1318	NCA	ADAPTOR PLATE, rad' mounting	1	
30	12G1319	£1.66	SCREW, adaptor, gearbox casing	1	
31	6K9012	£0.54	WASHER, locking	1	
32	2A3606	£0.37	'O' RING, oil suction	1	case to block
33	22A542B	£1.66	GASKET, oil drilling	1	
34	2A3637	NCA	PLATE, oil drilling blanking	1	
	MS3313	£31.40	MAGNETIC TRAP	1	
			(Replaces plate with magnetic sump plug extra safety in oil delivery pipe).		
35	2K4874	NCA	LOCKTAB	1	
36	BH604131	£1.00	BOLT, blanking plate to block	2	
37	DAM7335	£22.70	DRAIN PLUG, magnetic	1	
38	AED172	£1.15	WASHER, drain plug	1	
39	GUG3007SG	£2.20	GASKET SET, gearbox to engine	1	
	GUG3007SGA	£1.25	GASKET, gearbox to engine	1	front gasket
	GUG3007SGB	£1.25	GASKET, gearbox to engine	1	rear gasket with hole for oil pipe
40	AHU1959	£6.00	SEAL	1	crest front of crank
	AHU1959Z	£2.53	SEAL	1	to gearbox case
41	13H7286	£4.50	BUSH, gear lever steady rod	1	
42	SH504061	£0.28	SCREW, adaptor plate to housing	2	
43	GHF331	£0.17	WASHER, spring	2	
	GUG708010TS	£11.20	GASKET SET, gearbox	1	
	GUG708010TSZ	NCA	GASKET SET, gearbox	1	

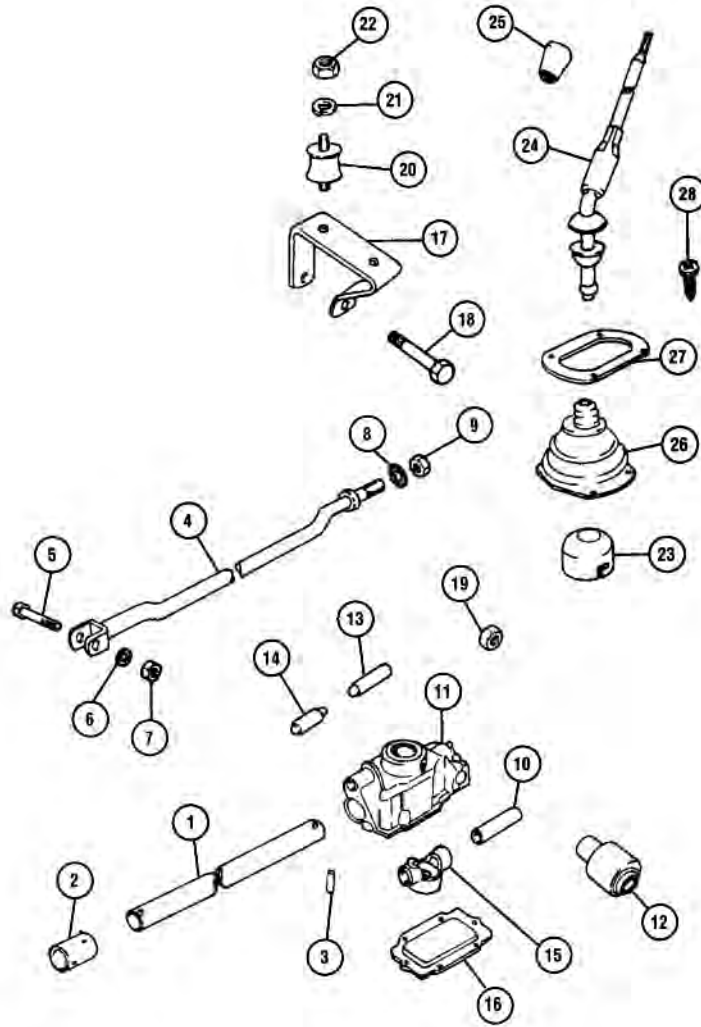

ill.	Part Number	Price £ea.	Description	Req.	Details
Gear Lever & Fittings					
1	22G1930	NCA	EXTENSION ROD, to gear lever	1	
2	42H1116	£28.00	COUPLING, for extension rod	1	
3	RPS1416	£2.63	ROLL PIN	3	coupling and extension rod
4	22A1936	£2.15	STEADY ROD, gearbox to gear lever	1	
	DAM5067	NCA	STEADY ROD, gearbox to gear lever	1	998cc To 1985
	UKN10032	NCA	STEADY ROD, gearbox to gear lever	1	1275cc 1985-On
5	BT605161	£1.04	BOLT, steady rod to gearbox	1	
6	GHF301	£0.22	WASHER, locking	1	
7	LNZ105	£0.79	NUT	1	
8	WA112081	£2.23	WASHER, star	1	
9	GHF275	£0.84	NUT	1	
10	42H1199	NCA	ROD, eye support	1	small type
11	DAM3670	NCA	HOUSING, gear lever	1	
12	42B413	£10.90	BUSH, housing steady	1	
13	DAM2670	£2.80	RETAINER PIN, long, gear lever	1	gear lever locator
14	22G2277	NCA	RETAINER PIN, short, gear lever	1	
15	22G2792	£40.00	EYE, extension rod	1	
	22G389	NCA	BUSH SEAT	1	cup seat bottom of gear lever
16	DAM8621	NCA	BASE PLATE, gear lever housing	1	
17	22G2026	NCA	BRACKET, floor to housing	1	
18	BT606281	NCA	BOLT, bracket to housing	1	
19	LNZ106	£1.56	NUT, locking	1	
20	22G2205	£3.32	MOUNTING, bracket to housing	2	
	21A956Z	£6.30	MOUNTING REAR	1	remote gear housing to under floor bracket
21	GHF332	£0.28	WASHER	4	
22	GHF201	£0.12	NUT	4	
23	22G1434	NCA	RETAINER, gear lever	1	
24	22A1932	NCA	ASSEMBLY, gear lever	1	

ill.	Part Number	Price £ea.	Description	Req.	Details
	MRAC1751	£42.00	GEAR LEVER, quick shift	1	rod type
	KAD1013218	£92.00	GEAR LEVER, quick shift	1	remote type
25	DAM4440	NCA	KNOB, gear lever	1	
26	CZH4278	£34.90	GAITER, gear lever	1	rod type
	22A608	£28.40	GAITER, gear lever	1	remote type
27	FJN10003	£2.63	RETAINER, for gaiter	1	rod type
	14A9942	£15.80	RETAINER, for gaiter	1	remote type
28	GHF426	£0.19	SCREW, gaiter retainer	4	

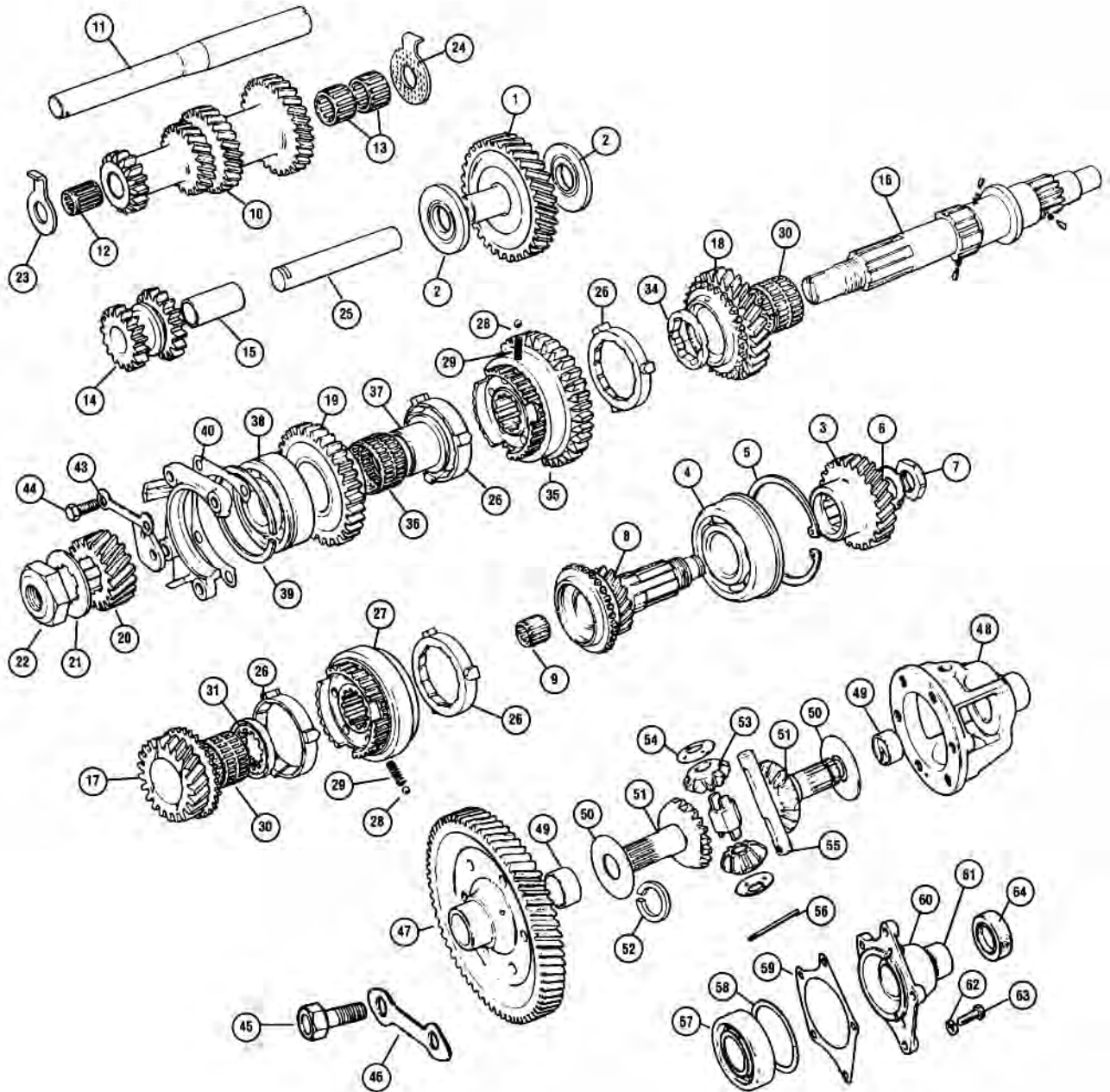

ill. Part Number Price £ea. Description Req. Details

Gearbox Internals

1	22G943	£100.00	GEAR, idler 31 teeth, shaft dia 0.75"	1	pre A +
	CSTR30	£62.00	GEAR, idler 30 teeth, shaft dia 0.75"	1	pre A+ straight cut EVO
	CSTR31	£205.00	GEAR, idler 30 teeth shaft dia 0.75" (Roller bearing).	1	pre A+ straight cut EVO
	DAM2924	£132.00	GEAR, idler 37 teeth, shaft dia 0.875"	1	998cc A+ and Cooper 1300
	CSTR30A	£62.00	GEAR, idler 30 teeth, shaft dia 0.875"	1	A+ straight cut EVO
	CSTR30TA	£176.00	GEAR, idler 30 teeth, shaft dia 0.875" (Timken bearing).	1	A+ straight cut EVO
	CSTR31	£205.00	GEAR, idler 30 teeth, shaft dia 0.875" (Roller bearing).	1	A+ straight cut EVO
	MRAC104	£218.60	DROP GEARS S/C, straight cut set	1	1-1 ratio 1275cc A+
	MRAC105	NCA	DROP GEARS S/C, straight cut set	1	1-1 ratio 1275cc A

Thrust Washers For Pre A+

2	22A1542	£17.50	THRUST WASHER, idler, green	a/r	0.130-0.131"
	22A1546	£17.00	THRUST WASHER, idler, black	a/r	0.132-0.133"
	22A1547	£19.00	THRUST WASHER, idler, white	a/r	0.134-0.135"
	22A1548	£18.00	THRUST WASHER, idler, blue	a/r	0.136-0.137"
	22A1549	NCA	THRUST WASHER, idler, red	a/r	0.138-0.139"
	DAM4822	£26.40	THRUST WASHER, idler, no code	a/r	0.131-0.133"

ill. Part Number Price £ea. Description Req. Details

Thrust Washers For A+

	DAM5914	NCA	THRUST WASHER, idler	a/r	0.130-0.135"
	DAM4823	£30.70	THRUST WASHER, idler, yellow	a/r	0.134-0.135"
	DAM4824	£15.00	THRUST WASHER, idler, red	a/r	0.136-0.137"
	DAM4825	£25.00	THRUST WASHER, idler, blue	a/r	0.138-0.139"
3	22G849	£58.00	GEAR, 1st motion, 24 teeth	1	pre A+
	DAM2925	NCA	GEAR, 1st motion, 29 teeth	1	998cc A+ and Cooper 1300cc
	CSTR230	NCA	GEAR, 1st motion, 23 teeth (Can be used with different primary gear to change gear ratio).	1	straight cut EVO
	CSTR240	£57.90	GEAR, 1st motion, 24 teeth (Can be used with different primary gear to change gear ratio).	1	straight cut EVO
	CSTR250	£57.90	GEAR, 1st motion, 25 teeth (Can be used with different primary gear to change gear ratio).	1	straight cut EVO
	MRAC104	£218.60	DROP GEARS S/C, straight cut set	1	1-1 ratio 1275cc A+
	MRAC105	NCA	DROP GEARS S/C, straight cut set	1	1-1 ratio 1275cc A series
4	ADU7619	£39.50	BALL BEARING, 1st motion	1	
5	22G850	NCA	CIRCLIP, bearing	1	alternatives
	22G851	NCA	CIRCLIP, bearing	1	
6	DAM4000	£2.50	LOCK TAB, washer	1	
7	2A3548	£6.46	NUT	1	
8	22G1093	£48.00	SHAFT, 1st motion	1	
	2A3643	£4.20	CIRCLIP, 1st motion shaft	1	retains nose bearing

ill.	Part Number	Price £ea.	Description	Req.	Details
9	CHM172	£5.40	BEARING, needle	1	
10	22G927	NCA	LAYGEAR, 15, 20, 25, 29 teeth	1	
11	22A1371Z	£18.20	LAYSHAFT	1	3 synchro gearbox
	22G931	£25.00	LAYSHAFT	1	engine No. ranges
12	13H9513	£4.44	BEARING, needle roller, small end	1	To 99H829P/871
13	CHM141	£3.92	BEARING, needle roller, large end	2	99H889AJ/423
14	22G1852	NCA	GEAR, reverse idler	1	99H889V/2864 +
15	22G825	NCA	BUSH, reverse gear	1	To 99H791P/320664
16	22G833	£140.00	SHAFT, 3rd motion	1	
17	22G1095	NCA	SPEED GEAR, 3rd	1	
18	22G1094	£85.00	SPEED GEAR, 2nd	1	
19	22G1096	£92.00	SPEED GEAR, 1st	1	
20	22A413	£48.00	PINION, final drive, 3.44:1	1	
	22A399	£20.90	PINION, final drive, 3.7:1	1	
	DAM5927	NCA	PINION, final drive, 2.95:1	1	
8	DAM3092	NCA	SHAFT, 1st motion	1	
	2A3643	£4.20	CIRCLIP, 1st motion shaft	1	retains nose bearing
9	13H9513	£4.44	BEARING, needle roller	1	
10	DAM3169	NCA	LAYGEAR, 15, 20, 25, 29 teeth	1	
11	DAM3187	£24.70	LAYSHAFT	1	
12	13H9513	£4.44	BEARING, needle roller, small end	1	A+ engine ranges
13	CHM141	£3.92	BEARING, needle roller, large end	2	99H829P/872 On
14	TUB10020	NCA	GEAR, reverse idler, 1 bush	1	99H889AJ/4234 On
	TUB10020	NCA	GEAR, reverse idler, 2 bush	1	99H889V/2865 On
15	22G825	NCA	BUSH, for DAM3189	1	99H791P/320665 On
	TUJ10001	£7.00	BUSH, for TUB10020	2	To 99H791P/Z500101
16	DAM168	NCA	SHAFT, 3rd motion	1	To 99HA53/P100101
	DAM7484	NCA	SHAFT, 3rd motion	1	
17	22G1095	NCA	GEAR, 3rd speed	1	
18	22G1094	£85.00	GEAR, 2nd speed	1	
19	22G1096	£92.00	GEAR, 1st speed	1	
20	DAM2679	£54.00	PINION, final drive, 3.44:1	1	
	DAM5927	NCA	PINION, final drive, 2.95:1	1	
8	DAM3167	NCA	SHAFT, 1st motion	1	18 teeth 1275cc GT
	DAM4930	£96.00	SHAFT, 1st motion	1	17 teeth
	2A3643	£4.20	CIRCLIP, 1st motion shaft	1	retains nose bearing
9	13H9513	£4.44	BEARING, needle roller	1	
10	DAM4931	NCA	LAYGEAR, 15, 21, 26, 30 teeth	1	A+ engine ranges
11	DAM3187	£24.70	LAYSHAFT	1	99H791P/Z500101 On
12	13H9513	£4.44	BEARING, needle roller, small end	1	99HA53P/100101 On
13	CHM141	£3.92	BEARING, needle roller, large end	2	all 99HB81P, B83P,
14	TUB10020	NCA	GEAR, reverse idler, 1 bush	1	B84P, B85P, C20P,
	TUB10020	NCA	GEAR, reverse idler, 2 bush	1	D80P, D81P, D83P,
15	TUJ10001	£7.00	BUSH, reverse gear	1/2	E20, E22, F15, F16,
16	DAM7484	NCA	SHAFT, 3rd motion	1	G30, G31, G32, G33,
17	DAM4933	£180.00	GEAR, 3rd speed	1	all Cooper 1300cc
18	DAM4932	NCA	GEAR, 2nd speed	1	
19	22G1096	£92.00	GEAR, 1st speed	1	
20	DAM2679	£54.00	PINION, final drive, 3.4:1	1	
	DAM2808	£99.00	PINION, final drive, 3.1:1/3.2:1	1	
21	DAM6140	£1.70	LOCK TAB, pinion to 3rd motion shaft	1	
22	22G48	£7.40	NUT, pinion	1	
	DAM7485	£4.69	NUT, pinion	1	(Use with 3rd motion shaft 22G833 & DAM168).
					(Use with 3rd motion shaft DAM7484).

Thrust Washers For Pre A+

23	22G856	NCA	T/WASHER, laygear, 0.123-124"	a/r	3.12-3.14mm
	22G857	NCA	T/WASHER, laygear, 0.125-126"	a/r	3.17-3.20mm
	22G858	NCA	T/WASHER, laygear, 0.127-128"	a/r	3.22-3.25mm
	22G859	NCA	T/WASHER, laygear, 0.130-131"	a/r	3.30-3.32mm

Thrust Washers For A+

	DAM3180	NCA	T/WASHER, laygear, 0.121-123"	a/r	3.07-3.12mm
	DAM3181	NCA	T/WASHER, laygear, 0.124-126"	a/r	3.10-3.20mm
	DAM3182	NCA	T/WASHER, laygear, 0.127-129"	a/r	3.22-3.27mm
	DAM3183	NCA	T/WASHER, laygear, 0.130-132"	a/r	3.30-3.35mm
24	22G860	£14.30	T/WASHER, laygear, large	1	
25	DAM8038	NCA	SHAFT, reverse idler gear	1	
26	22G2033	£14.40	BAULK RING	4	all gears
27	DAM7456	£230.00	HUB, 3rd & 4th synchro	1	
28	BLS107	£0.37	BALL BEARING, synchro hubs	6	3 per hub
29	22G2262	£2.00	SPRING, synchro hubs	6	3 per hub
30	AAU1816	£40.40	BEARING, 2nd & 3rd gear	2	needle roller
31	22G947	NCA	THRUST WASHER, 3rd gear	1	
34	22G839	NCA	THRUST WASHER, 2nd gear	1	
35	DAM7455	£220.00	HUB, synchro, 1st & 2nd	1	
36	AAU1815	£30.50	BEARING, needle roller	1	
37	22G837	NCA	JOURNAL, 1st gear	1	
38	AAU1365	£55.40	BALL BEARING, 3rd motion shaft	1	
39	ADU4992	NCA	SPRING RING, 3rd motion bearing	1	
40	2A3714	£1.55	SHIM, 0.002"	a/r	
	2A3715	£1.34	SHIM, 0.010"	a/r	
43	DAM2377	£3.40	LOCK TAB	2	
44	SH505071	£0.42	SCREW, retainer	4	

ill.	Part Number	Price £ea.	Description	Req.	Details
45	ATA7043	£1.15	BOLT, crown wheel to cage	6	
46	ATA7385	£2.46	LOCK TAB, crown wheel bolt	3	
Crown Wheels For Pre A+					
47	22A411	NCA	CROWN WHEEL, 62 teeth, 3.4:1	1	18 tooth pinion
Crown Wheels For A+					
	DAM2677	NCA	CROWN WHEEL, 62 teeth, 3.4:1	1	18 tooth pinion
	DAM6327	£267.30	CROWN WHEEL, 59 teeth, 3.1:1	1	19 tooth pinion
	DAM2806	NCA	CROWN WHEEL, 61 teeth, 3.2:1	1	19 tooth pinion
	DAM5925	NCA	CROWN WHEEL, 59 teeth, 2.95:1	1	20 tooth pinion
Competition Crown Wheel And Pinion Sets					
	CBTA1001	NCA	CROWN WHEEL + PINION, 3.46:1 (Stronger semi helical cut teeth for std or cross pin differentials).	1	
	CBTA1002	NCA	CROWN WHEEL + PINION, 3.76:1 (Stronger semi helical cut teeth for std or cross pin differentials).	1	
	CBTA1003	NCA	CROWN WHEEL + PINION, 3.93:1 (Stronger semi helical cut teeth for std or cross pin differentials).	1	
	CBTA1004	NCA	CROWN WHEEL + PINION, 4.07:1 (Stronger semi helical cut teeth for std or cross pin differentials).	1	
	CBTA1005	NCA	CROWN WHEEL + PINION, 4.31:1 (Stronger semi helical cut teeth for std or cross pin differentials).	1	
	CBTA1006	NCA	CROWN WHEEL + PINION, 4.57:1 (Stronger semi helical cut teeth for std or cross pin differentials).	1	
	CBTA1007	NCA	CROWN WHEEL + PINION, 4.67:1 (Stronger semi helical cut teeth for std or cross pin differentials).	1	
	CBTA1250	NCA	CROWN WHEEL + PINION, 3.46:1 (Stronger semi helical cut teeth for limited slip differentials only).	1	
	CBTA1248	NCA	CROWN WHEEL + PINION, 3.76:1 (Stronger semi helical cut teeth for limited slip differentials only).	1	
	CBTA1252	NCA	CROWN WHEEL + PINION, 3.93:1 (Stronger semi helical cut teeth for limited slip differentials only).	1	
	CBTA1246	NCA	CROWN WHEEL + PINION, 4.07:1 (Stronger semi helical cut teeth for limited slip differentials only).	1	
	CBTA1251	NCA	CROWN WHEEL + PINION, 4.23:1 (Stronger semi helical cut teeth for limited slip differentials only).	1	
	CBTA1249	NCA	CROWN WHEEL + PINION, 4.31:1 (Stronger semi helical cut teeth for limited slip differentials only).	1	
	CBTA1253	NCA	CROWN WHEEL + PINION, 4.67:1 (Stronger semi helical cut teeth for limited slip differentials only).	1	
	CBTA1250EVO	NCA	CROWN WHEEL + PINION, 3.47:1 (Straight cut teeth for limited slip differentials only).	1	
48	MRAC106	£191.50	DIFF UNIT, cross pin	1	four planet gears
	CAJJ3385	NCA	DIFF UNIT, cross pin	1	four planet gears
	CAJJ3387	NCA	DIFF UNIT, limited slip differential (90/35 ramped Evolution LSD is an upgraded version of the popular Salisbury clutch type LSD).	1	race
	CAJJ3387A	NCA	DIFF UNIT, limited slip differential	1	rally, 45/45 ramp
	CAJJ3387B	NCA	DIFF UNIT, limited slip differential	1	rally, 90/50 ramp
49	ATA7378	£5.50	BUSH, diff housing & crown wheel	2	
50	BTA101	£2.00	THRUST WASHER, fibre	2	
51	22G1952	NCA	SHAFT, differential output	2	pre A+
	DAM3114	NCA	SHAFT, differential output	2	all A+
	CCN122	£1.63	CIRCLIP, LSD output shaft	2	required to hold output shafts to differential side plate
52	22G2688	£7.10	CIRCLIP, output shaft	2	
53	2A7015	NCA	PLANET GEAR	2	pre A+
	DAM6624	£14.00	PLANET GEAR	2	all A+
54	2A7062	£2.40	T/WASHER, planet gear, 0.035"	2	no lip
	2A7062Z	£2.95	T/WASHER, planet gear, 0.054"	2	
	DAM5071	£4.40	T/ WASHER, planet gear to cage	2	with lip
55	C-BTA166	£15.80	DIFF PIN, competition	1	
56	RPS1418	£0.79	ROLL PIN, cross pin to diff. cage	1	
57	AHU1856	£13.40	BEARING, differential cage	2	
58	2A3535B	NCA	SHIM, differential bearing, 0.002"	a/r	
	2A3534B	NCA	SHIM, differential bearing, 0.003"	a/r	
	DAM3108	£1.45	SHIM, differential bearing, 0.006"	a/r	
	DAM3109	£1.30	SHIM, differential bearing, 0.010"	a/r	
	DAM3633	£1.50	SHIM, differential bearing, 0.020"	a/r	
59	TRK10004B	£0.62	GASKET, output shaft cover	2	
60	CHM85	£75.00	HOUSING, output shaft	2	
61	2A3538	£3.20	BUSH, output shaft housing	2	
62	GHF332	£0.28	WASHER, locking	10	
63	SH505101	£0.62	SCREW	10	bearing to differential housing
64	ADU5738	£1.10	SEAL, output shaft housing	2	
	AHU1082	£2.23	SEAL, output shaft housing	2	hardy spicer S type

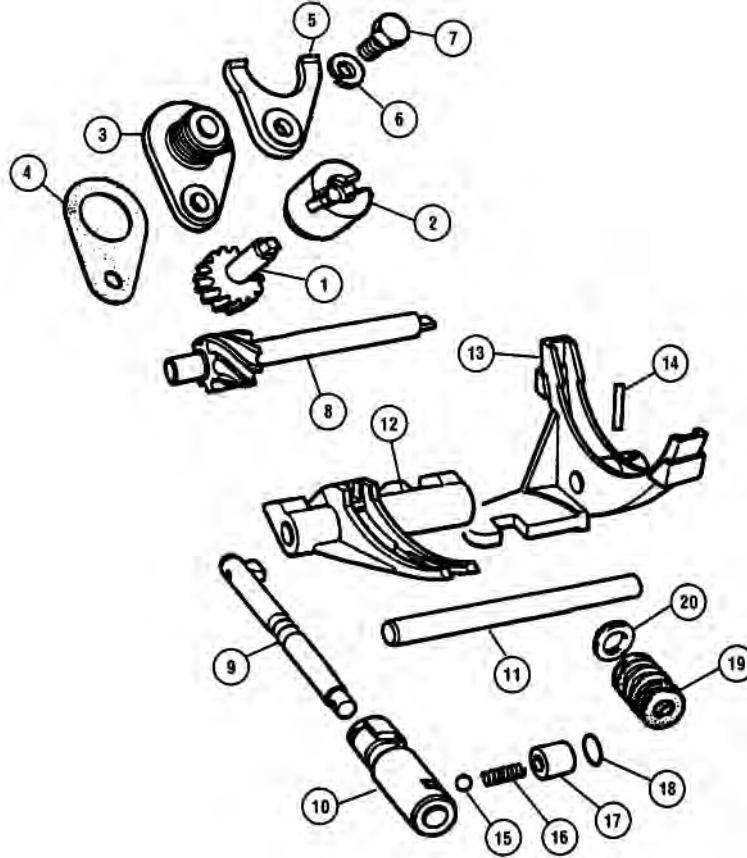

ill.	Part Number	Price £ea.	Description	Req.	Details
Gearbox Internals					
1	22A1881	NCA	PINION, speedo 17 teeth	1	To 1984 10" wheels
	DAM2905	NCA	PINION, speedo 16 teeth	1	
2	2A3624	£1.36	BUSH, metal seating	1	12" wheels
3	DAM8488	NCA	ADAPTOR, speedometer	4	cable to pinion housing
4	2A3628	NCA	GASKET	1	
5	22A862	NCA	FORK	1	
6	GHF331	£0.17	WASHER, locking	1	
7	SH504071	£0.42	SCREW, fork retaining	1	
8	2A3720	£55.70	SPINDLE, speedo drive, (6 teeth)	1	10" wheels
	DAM6028	£70.00	SPINDLE, speedo drive, (7 teeth)	1	blue gear 12" wheels
9	22G1858	£51.00	SHAFT SELECTOR	1	
10	22G1844	NCA	INTERLOCKING SPOOL	1	
11	22G1854	NCA	SHAFT SELECTOR	1	for selector forks
12	DAM7425	£75.00	SELECTOR FORK, 1st & 2nd	1	
13	TSP100400	NCA	SELECTOR FORK, 3rd & 4th	1	
14	22G2595	£2.30	ROLL PIN, (fork to rod), 3rd & 4th	1	
15	BLS110	£0.37	DETENT BALL	1	
16	22G2083	£0.42	DETENT SPRING	1	

ill.	Part Number	Price £ea.	Description	Req.	Details
17	22G1870	NCA	DETENT SLEEVE	1	
18	22G1417	£0.68	'O' RING, for sleeve	1	
19	DAM3022	£2.30	GAITER, rod change oil seal	1	
20	AHU1672	£1.70	OIL SEAL, gear linkage	1	rod change
	AHU1672Z	£1.25	OIL SEAL, gear linkage, aftermarket	1	gear linkages
	CAJJ4014	£520.00	GEAR KIT, remote	1	straight cut
	CSTN76	NCA	GEAR KIT, rod	1	straight cut
	CSTN77	£520.00	GEAR KIT, rod A+	1	straight cut
	CAHT54	£30.00	PICK UP PIPE, central	1	

(To ensure a constant supply of oil during hard cornering).

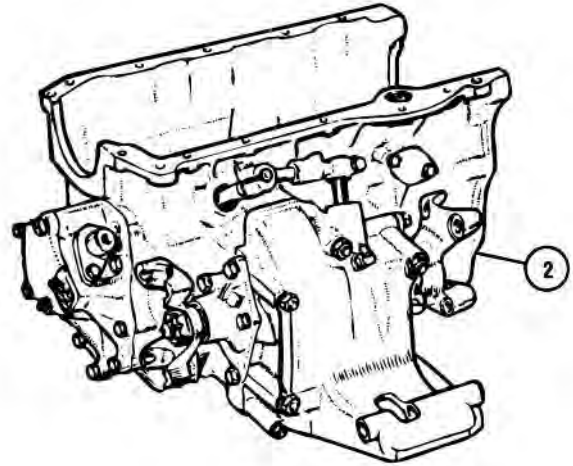
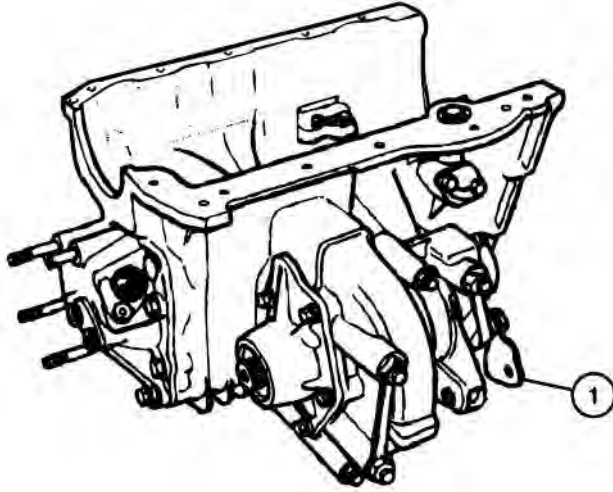

iii. Part Number Price £ea. Description Req. Details

Reconditioned Gearboxes

Reconditioned gearboxes are a great way to rectify problems with the Minis bottom end. Not everyone is able to strip down a Mini gearbox and rebuild it themselves as the procedure is quite complex.

Common problems with the Minis gearboxes are jumping out of gears when driven or stiffness selecting gears or crunching gears when selected. Some of these issues can be caused by bulk rings being badly worn or teeth on the gears being worn or missing. All these problems require the engine and gearbox to be removed from the in order to be rectified. Our reconditioned gearboxes are a great way to keep your Mini on the road where it belongs.

Please note you will need to retain the speedo pinion from your old gearbox and ensure you ask for the correct differential ratio! This is so your speedo reads correctly after fitting a reconditioned gearbox.

1	MT2101	£504.00	GEARBOX, reconditioned, (exchange)	1	rod type
2	MT2102	£481.00	GEARBOX, reconditioned, (exchange)	1	remote type

iii. Part Number Price £ea. Description Req. Details

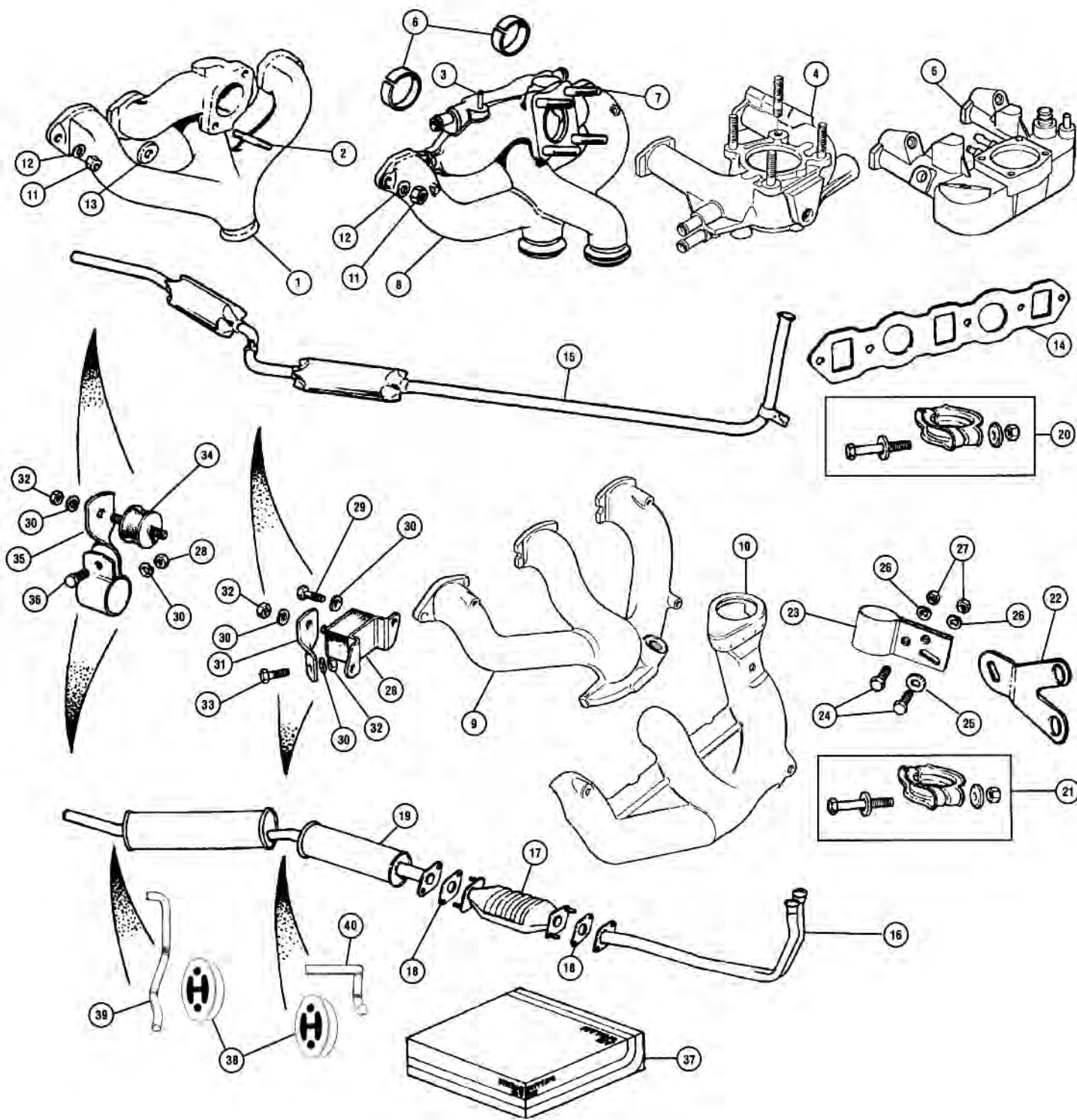

ill.	Part Number	Price £ea.	Description	Req.	Details
Manifolds & Fittings					
1	12G3279		NCA MANIFOLD	1	998cc models
2	CHS2613	£1.45	STUD, 3/8" dia UNC/UNF 1-5/8" long	2	manifold to carburettor
	CHS2614	£1.42	STUD, 3/8" dia UNC/UNF 1-3/4" long	4	
	CHS2616	£1.36	STUD, 3/8" dia UNC/UNF 2" long	2	
	CHS2514	£2.12	STUD, 5/16" dia UNC/UNF 1-3/4" long	2	
	CHS2515	£1.36	STUD, 5/16" dia UNC/UNF 1-7/8" long	2	
	CHS2516	£2.05	STUD, 5/16" dia UNC/UNF 2" long	2	

ill.	Part Number	Price £ea.	Description	Req.	Details
3	CAM6618		NCA MANIFOLD, Inlet	1	Copper 1300cc + SE
4	LKB10477		NCA MANIFOLD, inlet	1	spi 1991-0n
5	LKB106930		NCA MANIFOLD, inlet	1	mpi 1996-0n
	MT3603	£59.40	MANIFOLD, inlet (For 1.5" and 1.75" carburettors).	1	high flow alloy inlet
	LP4012	£171.00	MANIFOLD, inlet	1	for twin SU's (HS2 or HS4)
	C-AEG489	£78.00	MANIFOLD, inlet	1	for twin SU's (HS4 or HS6)
	AEG349	£6.60	THROTTLE BRACKET	1	for twin SU's

ill.	Part Number	Price £ea.	Description	Req.	Details
	TT10850	£161.50	MANIFOLD, inlet (Single Weber inlet manifold 10cm (4 inch) long. Will require bulkhead modifications).	1	
	TMG10850	£186.30	MANIFOLD, inlet (Single Weber inlet manifold 15cm (6 inch) long. Will require bulkhead modifications).	1	
	TWM0071	£353.00	MANIFOLD, inlet (Single Weber inlet manifold 15cm (6 inch) long. Supplied complete with direct acting throttle linkage. Will require bulkhead modifications).	1	
	LP42411	£94.90	LINKAGE KIT (Single cable, these are very easily installed and offer smooth operation).	1	Weber single carburettor
6	12G297	£1.36	RING, manifold locating	2	
7	CHS2514	£2.12	STUD, short	2	
	CHS2516	£2.05	STUD, long	2	
8	CAM6745	NCA	MANIFOLD, exhaust	1	Copper 1300cc + SE
9	LKC10090	NCA	MANIFOLD, exhaust	1	spl and mpi 1991-On
10	LKK10025	NCA	HEAT SHIELD, for injection manifold	1	spl and mpi 1991-On
	GAC8463X	£98.50	MANIFOLD LCB (Maniflow long centre branch (LCB) exhaust manifold for applications up to 100bhp includes primary pipes and Y piece with clamps).	1	
	MT6502	NCA	MANIFOLD LCB (Long centre branch manifold with link pipe to catalyst, carburettor model).	1	
	MT6505	£156.00	MANIFOLD LCB (Long centre branch manifold with link pipe to catalyst, injection model, mild steel).	1	
	MT6502	NCA	MANIFOLD, Cooper freeflow	1	stainless steel
11	GHF261	£0.42	NUT, brass, manifold to cyl. head	6	all models
	GHF261A	£2.42	NUT, brass (Longer ST version of GHF261).	6	longer alternative
12	GHF301	£0.22	WASHER, plain	2	
13	12A1211	£0.79	WASHER, plain	4	
14	AJM601	£2.05	GASKET, manifold to cylinder head	1	mpi models
	LKJ100580EVA	£7.50	GASKET, manifold to cylinder head	1	ERA turbo
	GUG704063MG	£16.00	GASKET, manifold to cylinder head	1	
	TMG10836	£4.44	GASKET, manifold to cylinder head (Large bore allows fitment of performance exhaust manifolds with larger primary pipes).	1	

Exhausts & Fittings

15	GEX106	£54.00	EXHAUST SYSTEM, single box	1	saloon
	GEX154	£54.60	EXHAUST SYSTEM	1	twin box saloon
	GEX1285	£31.80	EXHAUST DOWNPIPE (For single box GEX1562 (from exhaust manifold to side exit kink at front of rear subframe).	1	front repair section
	GEX155	£63.00	EXHAUST SYSTEM, 2x silencers (Mild steel).	1	van & estate
16	GEX12052	£62.95	DOWNPIPE, single pipe	1	carb std to catalyst
	WCP10021	NCA	SAMPLE PIPE	1	C/O sample pipe attaches To GEX12052
	GEX12017	£234.50	DOWNPIPE, twin pipes	1	Cooper 1300cc to catalyst
	GEX12043	£133.50	DOWNPIPE, twin pipes with flat face flange 1300cc spi and mpi to catalyst	1	
	GEX7779	£2.95	GASKET	1	for GEX12043
17	GEX8069	£253.60	CATALYST ASSEMBLY	1	spl and mpi 1991-On
	FX110041	£2.05	NUT, catalyst	4	
18	GEX7761	£1.92	GASKET, catalyst flange	2	
19	GEX33479	£110.60	TWIN BOX, rear (From catalyst back to vin 22123).	1	Cooper 1300cc
	GEX33515	£142.20	TWIN BOX, rear (From catalyst back from vin 22124).	1	Cooper 1300cc
	GEX33516	£109.70	TWIN BOX, rear	1	Cooper spi from catalyst back
	GEX3674	£29.95	SINGLE BOX, rear	1	1959-69
	C-STR811	£80.00	SINGLE BOX, rear (With intermediate pipe from catalyst).	1	RC40 rear box
	C-STR811S	£130.00	SINGLE BOX, rear (With intermediate pipe from catalyst).	1	stainless steel RC40 rear box
	GEX33519	£84.00	TWIN BOX, rear	1	standard spi from catalyst back
	GEX33679	£214.40	TWIN BOX, rear	1	mpi from cat. back
20	GEX7046	£2.53	CLAMP, pipe to manifold	1	all 998cc models
21	GEX7801	£3.92	CLAMP, pipe to manifold	2	Cooper 1300cc + SE
22	GEX7526	£3.18	BRACKET, gearbox to front pipe	1	

ill.	Part Number	Price £ea.	Description	Req.	Details
23	GEX7053	£3.30	CLIP, front pipe to gearbox bracket	1	
24	SH605051	£0.32	SCREW, clip to bracket	2	998cc models
25	GHF301	£0.22	WASHER	2	
26	GHF331	£0.17	WASHER, locking	7	
27	GHF201	£0.12	NUT	2	
28	GEX7081	£2.23	MOUNTING, centre, rubber	1	
29	SH605051	£0.32	SCREW, mounting to subframe	2	
30	GHF332	£0.28	WASHER, locking	2	
31	GEX7082	£0.62	STRAP, centre, twisted	1	998cc models
	GEX7273	£1.04	STRAP, centre, twisted	1	van, pick up, estate
	GEX7778	NCA	STRAP, centre, twisted	1	Cooper 1300cc + SE
	GEX7082	£0.62	STRAP, centre, twisted	1	1275cc GT, S, RC40
32	GHF201	£0.12	NUT	1	
33	SH605071	£0.60	SCREW, strap to centre clip	1	
34	GEX7251	£1.42	MOUNTING, bobbin, rubber	1/2	
	GEX7251P	NCA	MOUNTING, bobbin, poly	1/2	
35	GEX7084	£1.92	CLIP, rear mount, twisted	1	998cc models
	GEX7778	NCA	STRAP, twisted, rear	1	Cooper 1300cc + SE
	GEX7249	£2.05	STRAP, rear (Fits to subframe via two bobbins).	1	1275cc GT, S, RC40
36	GHF120	£0.28	SCREW, clip	1	
37	GEX9551	£11.90	FITTING KIT, exhaust	1	998cc models
	GEX40FK	£12.50	EXHAUST FITTING KIT	1	fitting kit for RC40 exhaust
38	GEX7661	£3.55	EXHAUST HANGER, rubber	2	late type exhaust
	GEX7661P	NCA	EXHAUST HANGER, poly	2	late type exhaust
39	KHU10011	£3.25	HANGER BRACKET, large	1	requires welding
40	KHU10012	£2.50	HANGER BRACKET, small	1	to subframe

Performance Exhausts

Note: Also see Accessories section for our full range of sports exhausts.

	GEX40RC	£60.76	EXHAUST SYSTEM, sports (Inc: intermediate pipe to downpipe).	1	RC40 two box system
	GEX50RC	£228.00	EXHAUST SYSTEM, sports (Two box system includes intermediate pipe to downpipe).	1	stainless steel RC40
	PM34	£31.10	LINK PIPE, stainless steel	1	to rear boxes
	MT6501	NCA	CARBON FIBRE REAR BOX (Carbon fibre box with stainless steel end caps, weighs just 3.7kg).	1	1992-On late type hangers
	AN180V	£17.00	INTERMEDIATE PIPE (Connects direct from Cooper freeflow manifold to performance rear boxes, requires shortening for LCB manifolds).	1	
	PME41	£154.00	REAR BOX (With outward rolled lip).	1	centre exit single tailpipe
	PME42	£162.20	REAR BOX (With straight cut).	1	centre exit twin tailpipe
	FES200	£155.00	REAR BOX (With outward rolled lip).	1	side exit single tailpipe
	FES201	£198.00	REAR BOX (With DTM style upswept straight cut).	1	centre exit twin tailpipe
	WPE3001X	£14.40	FITTING KIT	1	
	WPE3002X	£27.60	FITTING KIT	1	
	WPE3003X	£42.00	FITTING KIT	1	
	WPE3004X	£9.60	FITTING KIT	1	
	WPE1104X	£4.24	BLANKING PLUG, lambda sensor	1	

Note: When fitting any exhaust system to the classic Mini check that the engine mounting and engine stabiliser bushes are in good condition! Excessive movement of the engine will damage the exhaust causing leaks and bad running. See the Engine mountings section.

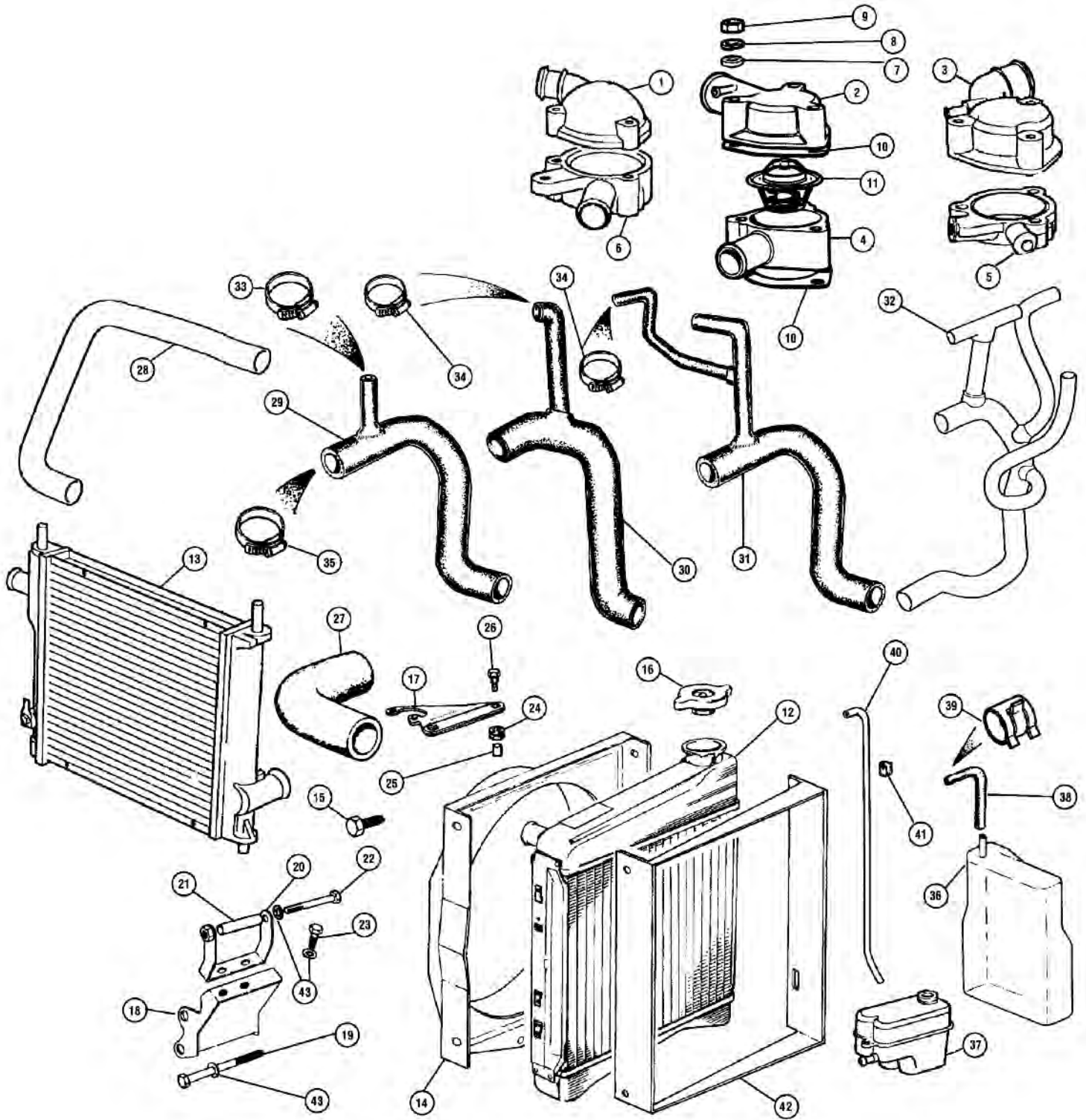

ill.	Part Number	Price £ea.	Description	Req.	Details
Radiator and Hoses					
1	12G103	£7.80	HOUSING, thermostat	1	all 998cc and A series 1275cc
	12G103Z	NCA	HOUSING, thermostat	1	all 998cc and A series 1275cc
2	PEQ10010	NCA	HOUSING, thermostat	1	standard 1300cc 1990-On
	PEQ10019	£37.00	HOUSING, thermostat	1	Cooper 1300cc
3	PEQ100650	NCA	HOUSING, thermostat (Front mounted radiator).	1	mpi 1996-On
	PEQ100690	£55.00	HOUSING, thermostat	1	spi
4	PEM10036	£40.00	PLATE, thermostat housing	1	
5	PEG100030	£40.00	PLATE, thermostat housing (12mm drilling for MEK100060 temperature sensor).	1	sandwich plate mpi 1996-On
6	PEG10002	£58.10	PLATE, thermostat housing (10mm outlet).	1	sandwich plate
7	GHF301	£0.22	WASHER,	3	
8	GHF332	£0.28	WASHER, locking	3	
9	GHF201	£0.12	NUT	3	
	DAM7760	£3.32	BOLT, thermostat housing	3	housing and sandwich plate
10	GTG101	£0.37	GASKET, thermostat	a/r	
11	GTS102	£3.58	THERMOSTAT, 74°C, (165°F)	1	summer
	GTS104	£3.80	THERMOSTAT, 82°C, (180°F)	1	standard To 1985
	GTS106	£4.43	THERMOSTAT, 88°C, (190°F)	1	standard 1985-On
	AJJ4012	£9.70	THERMOSTAT, blanking sleeve kit	1	replaces thermostat
12	GRD210	£83.20	RADIATOR	1	all 998cc models
	GRD172	£84.00	RADIATOR	1	Cooper 1300cc
13	GRD974	£84.00	RADIATOR, front mounted	1	mpi 1996-On

High Performance Radiators

GRD4442	£160.00	RADIATOR, 2 core, road/race	1	high performance radiator
GRD4442TDF	£77.10	RADIATOR, 3 core, road/race (With sensor boss at top)	1	high performance radiator
GRD4443	£160.00	RADIATOR, 2 core, road/race (With fan switch)	1	high performance radiator
GRD4444	£150.00	RADIATOR, 4 core, grass track	1	high performance radiator
MT3104	£255.00	RADIATOR, alloy	1	side mounted

Note: Aluminium radiators are made to high specification, aluminium radiators are substantially more efficient than the original unit in which they replace. This leads to an overall increase in performance and reliability.

14	PGK10034	£85.00	COWLING, radiator	1	
15	SH604031	£1.04	SCREW, radiator to cowl	4	
16	GRC180	£2.78	RADIATOR CAP, 13 psi	1	998cc To 1976
	GRC180SS	£6.14	RADIATOR CAP, 13 psi, stainless steel	1	998cc To 1976
	GRC1110	£2.78	RADIATOR CAP, 15 psi	1	998cc 1976-On
	GRC1110SS	£6.14	RADIATOR CAP, 15 psi, stainless steel	1	998cc 1976-On
	GRC207	£5.62	EXPANSION CAP	1	Cooper 1300cc
17	CAM4619	£14.00	BRACKET, radiator top mount	1	all 998cc models
	12G617	£12.10	BRACKET, radiator top mount	1	1275cc and S
	12G617S	£11.50	BRACKET, radiator top mount	1	1275cc and S stainless steel
	PCU10135	£16.50	BRACKET, radiator top mount	1	Cooper 1300cc
18	12A361	£116.60	BRACKET, radiator to engine	1	all models
19	HBZ534	£1.96	BOLT, bracket to gearbox	2	
20	12A2153	£15.00	BRACKET, lower radiator mounting	2	
21	ARP1073	£11.40	SPACER	1	
22	BH605261	£1.52	BOLT, cowl to bracket	1	
23	SH605051	£0.32	SCREW	2	
24	11G227	£1.80	GROMMET, upper radiator mounting	2	all 998cc models
25	CAM4415	£5.00	SLEEVE, for grommet	2	
	11G228	£3.20	SLEEVE, for grommet, 11G227	2	
	12A1985	£2.63	SLEEVE, for grommet, 11G227	2	replaces 11G228
26	GHF117	£0.28	SCREW	2	
	CAM4618	£1.50	BUSH, top mounting	2	Cooper 1300cc + SE
27	GRH244	£4.92	TOP HOSE	1	1959-67
	GRH245	£3.92	TOP HOSE	1	all 998cc models
	GRH247	£3.58	TOP HOSE	1	1275cc and S
	GRH469	£11.00	TOP HOSE	1	1275cc GT
	GRH1140	£9.95	TOP HOSE	1	Cooper 1300cc
	GRH1212	£23.30	TOP HOSE	1	Cooper spi
28	GRH1465	£12.00	TOP HOSE (Front mounted radiator fitment).	1	mpi 1996-On
	GRH1216	£110.20	HOSE	1	spi thermostat to manifold and heater
29	GRH240	£10.20	BOTTOM HOSE	1	all 998cc models
	GRH468	£14.40	BOTTOM HOSE	1	Clubman

ill.	Part Number	Price £ea.	Description	Req.	Details
30	GRH1159	£114.10	BOTTOM HOSE (Modify GRH1159 to suit Cooper SE 1300cc models).	1	Cooper SE 1300cc
31	GRH1159	£114.10	BOTTOM HOSE	1	Cooper 1300cc
	GRH1242	£106.20	BOTTOM HOSE	1	Cooper spi
32	GRH1466	£58.00	BOTTOM HOSE (Front mounted radiator fitment (water pump/rad/expansion tank/water valve/thermostat).	1	mpi 1996-On
33	GHC11022	£2.05	HOSE CLIP, heater outlet hose	1	To 1989
34	GHC11025	£2.17	HOSE CLIP, heater outlet hose	2	1990-On
35	GHC11035	£2.45	HOSE CLIP, top & bottom hose	4	
36	PCF10056	NCA	EXPANSION TANK	1	not stainless steel
	PCF10097	NCA	EXPANSION TANK	1	1991-96
37	PCF101240	£77.00	EXPANSION TANK	1	mpi 1996-On front mounted radiator fitment
38	GRH1213	NCA	HOSE, expansion tank	1	Cooper 1300cc
39	UKC3803	£0.84	CLIP, expansion hose	2	
40	GRH1001M	£2.12	PIPE, overflow	1	all 998cc models
41	ARA951	£1.45	CLIP, overflow pipe to cowl	2	
42	KRD10009	NCA	SEAL, rubber, radiator to fliitch	1	Cooper 1300cc
43	GHF332	£0.28	WASHER, spring	4	

Fan Switches

Fan switches for use with GRD4442TDF, MT3104 can be used to switch any electric fan on or off. Electronic fan controller (RFC010) can be adjusted for different temperatures.

IM50100	£8.00	Thermo switch, 82-68°C	1
IM50120	£8.30	Thermo switch, 88-79°C	1
IM50200	£8.80	Thermo switch, 92-87°C	1
IM50250	£8.30	Thermo switch, 88-74°C	1
RFC010	£78.00	Electronic fan controller (Thread fitting M22 x 1.5).	1

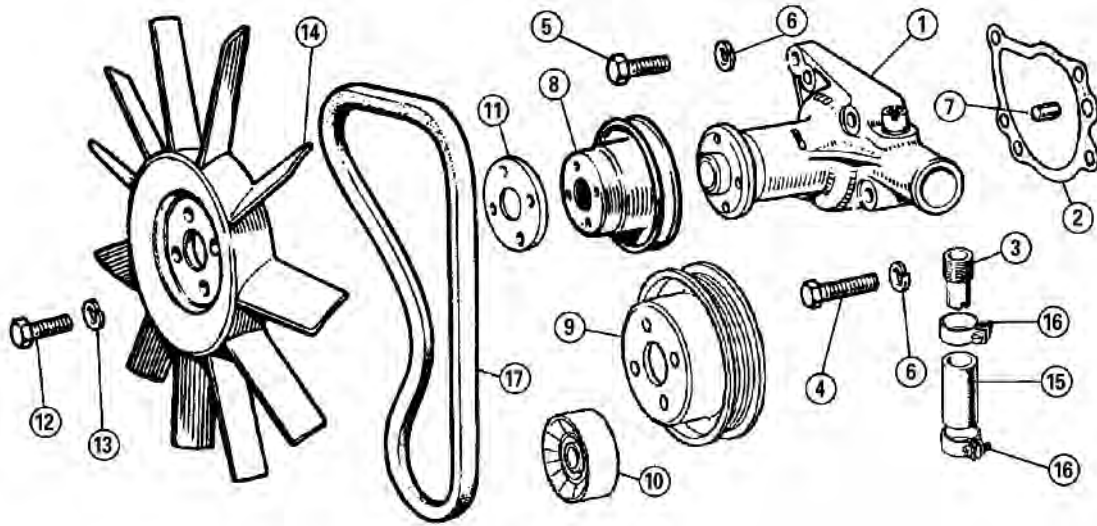

ill.	Part Number	Price £ea.	Description	Req.	Details
Water Pump					
1	GWP132	£18.00	WATER PUMP	1	998-1098cc
	GWP134	£18.00	WATER PUMP, with bypass outlet	1	1275cc
	GWP187	£18.70	WATER PUMP, no bypass outlet	1	
	GWP188	£36.40	WATER PUMP, no alternator lug	1	MPI 1996 on
2	88G215	£0.60	GASKET, water pump	1	
3	12A2075	£5.95	ADAPTOR, on cylinder head	1	all 998cc models
4	SH605141	£1.15	BOLT, pump to block, long	2	
	TAM1180	£0.73	BOLT, flanged, pump to block, long	2	Cooper 1300cc
5	SH605101	£0.84	BOLT, pump to block, short	2	all 998cc models
	TAM1178	£1.25	BOLT, flanged, pump to block, short	2	Cooper 1300cc
6	GHF332	£0.28	WASHER, locking	4	
7	12G2077	NCA	DOWEL, pump to block	2	
8	CAM6239	NCA	PULLEY, water pump	1	To 1985
	CAM6239A	£63.00	PULLEY, water pump, aluminium	1	To 1985
	CAM6408	£46.60	PULLEY, water pump	1	1985-On
9	PEZ100100	NCA	PULLEY, water pump, multi V belt	1	mpi 1996-On
10	PQR10028	£49.10	PULLEY TENSIONER	1	mpi 1996-On
11	12A312	NCA	SPACER, fan to pulley	1	
12	SH604041	£0.37	SCREW, fan to pump	4	
13	GHF331	£0.17	WASHER, locking	4	

ill.	Part Number	Price £ea.	Description	Req.	Details
14	12G2129	£19.00	FAN, 11 blade, plastic	1	1.5" thick blades
	2A998	£43.00	FAN, 6 blade, metal	1	export & performance
	2A997	£34.40	FAN, 2 blade, metal	1	special tuning
Note: 2A997 can also be doubled up to make a 4 blade fan for quieter running. For 4 blade fan simply order two 2A997.					
15	GZA2083	£1.42	HOSE, bypass	1	
	GZA2083X	£2.63	HOSE, bypass, silicone	1	
	GZA2083Z	£4.00	HOSE REPAIR KIT, bypass hose	1	998cc models
16	3H2963	£0.94	CLIP, bypass hose	2	
	CAM4126	£8.50	PLUG COVER	1	
(Covers bypass tube on cylinder head or water pump when bypass is not being used).					
17	GCB10813	£5.42	FAN BELT, 813mm long	1	To 1985
	GCB10838	£4.63	FAN BELT, 838mm long	1	A115 alternator 1981-85
	GCB10825	£5.20	FAN BELT, 825mm long	1	A127 alternator 1985-On
	GMB50920	£10.80	FAN BELT, multi groove	1	mpi 1996-On

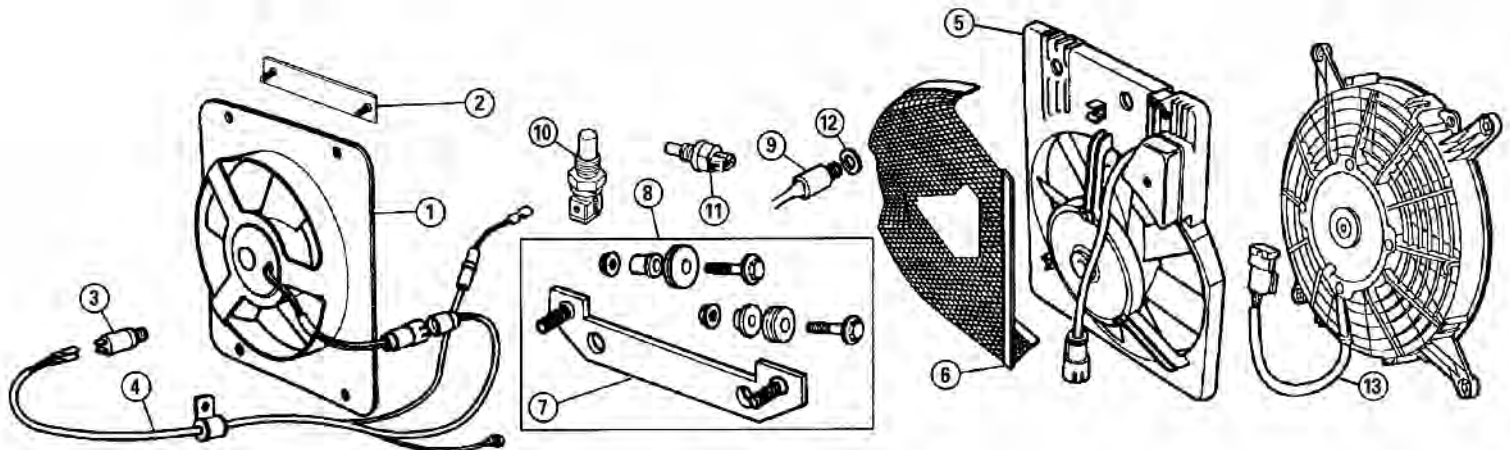

ill.	Part Number	Price £ea.	Description	Req.	Details
Electric Cooling Fan					
1	PGF10038	NCA	FAN	1	
2	PGU10006	NCA	BRACKET, cowl to inner wing	1	
3	YWL10010	£79.20	THERMAL SWITCH & SEAL	1	Cooper SE models
4	YMV10069	NCA	HARNESS	1	
5	PGG10046	NCA	FAN, long	1	
6	PGL10008	NCA	SHIELD	1	
7	PGU10007	£21.60	BRACKET, fan to inner wing	1	Cooper 1300cc
8	PGG10046FK	NCA	MOUNTING KIT, fan to fiitch	1	
9	GVS104	£8.40	THERMAL SWITCH	1	
10	GTR185	£9.90	TEMPERATURE TRANSMITTER	1	spi 1991-On

ill.	Part Number	Price £ea.	Description	Req.	Details
11	MEK100060	£10.50	TEMPERATURE TRANSMITTER	1	mpi Mini (brown)
12	PYF10036	NCA	WASHER, sealing	1	
	MDY100040	£2.59	WASHER, sealing	1	mpi for MEK100060
13	PGG10058	£166.40	FAN ASSEMBLY	1	1991-96
	PGG100890	£121.60	FAN ASSEMBLY	1	mpi 1996-On
(Front mounted radiator fitment).					

Note: See Performance in the Accessories section for high quality Cobalt silicone hose kits.

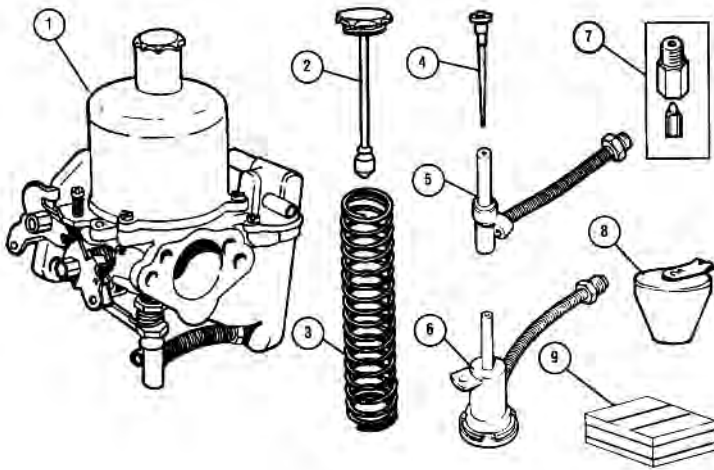

HS4

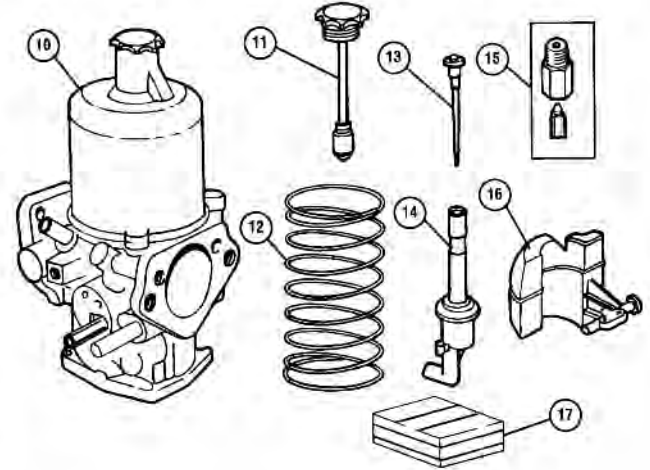

HIF44

ill. Part Number Price £ea. Description Req. Details

Carburettors

HS2 Carburettor

AUD327T	£539.80	CARBURETTOR	1
GAC6153X	£47.20	REBUILD KIT, (single)	1
AUD662T	£619.80	CARBURETTORS, (pair)	1

HS4 Carburettor

1	FZX3012	£325.30	CARBURETTOR, plain jet	1	1973-76
	FZX3014	£320.10	CARBURETTOR, waxstat jet	1	1976-82
	FZX3013	£325.30	CARBURETTOR, waxstat jet	1	1982-0n
2	AUC8103A	£15.40	CAP & DAMPER, dashpot	1	
3	AUC4387	£6.20	SPRING, dashpot, red	1	
4	NZX4005	£13.70	NEEDLE, ADE	1	
	NZX4008	£13.70	NEEDLE, ADH	1	
	CUD1002	£13.70	NEEDLE, AAC	1	

Note: Due to the number of different types of needle we have been unable to list all the carburettor tag numbers, (the number is on a tag on the dashpot cover screw) when ordering needles please check the three letter code stamped around the top of the needle. Please contact your local Moss Europe Ltd branch for help.

5	AUD9451A	£20.40	JET ASSEMBLY	1	
6	LZX1111A	£45.30	JET ASSEMBLY, waxstat cap	1	
7	WZX1101A	£10.50	FLOAT VALVE KIT, needle & seat	1	
8	WZX1300	£11.35	FLOAT, plastic	1	
	GAC9201X	£10.70	GROSE JET	1	
			(Superior replacement for original style needle and seat. The ball bearing design allows a much greater area of the surfaces to meet for a better seal and longer life).		
	WZX1852X	£38.50	SERVICE KIT	1	single HS4 pre waxstat main jet, needle valve, gaskets and washers).
	WZX1865	£80.70	SERVICE KIT	1	single HS4 waxstat (Inc: Instructions, diagrams, new main jet, needle valve, gaskets & washers).
9	CRK219	£67.00	REBUILD KIT	1	plain jet (Includes All service items and throttle shaft, throttle disc, 2 screws and 2 bushes, (needles not included).
	CRK227	£86.50	REBUILD KIT	1	plain jet (With over run throttle disc includes all service items and throttle shaft, throttle disc, 2 screws and 2 bushes, (Needles not included).
	CRK121	£76.20	REBUILD KIT	1	waxstat jet (Includes All service items and throttle shaft, throttle disc, 2 screws and 2 bushes, (needles not included).

HIF38 Carburettor

FZX3004	NCA	CARBURETTOR	1
---------	-----	-------------	---

ill. Part Number Price £ea. Description Req. Details

HIF44 Carburettor

10	FZX3006	£398.80	CARBURETTOR	1
	GAC8100	£46.60	SERVICE KIT	1
			(Includes Instructions, new main jet, needle valve, gaskets and washers).	
	CRK167	£81.28	REBUILD KIT	1
			(Includes All service items and throttle shaft, throttle disc, 2 screws and 2 bushes).	
11	LZX2085	£24.30	CAP & DAMPER, dashpot	1
12	AUD4355	£3.90	SPRING DASHPOT, red	1
13	NZX8071	£13.70	NEEDLE, BFY	1
14	WZX1453A	£17.95	JET	1
15	WZX1099A	£18.90	FLOAT VALVE KIT, needle & seat	1
16	WZX1509A	£12.25	FLOAT, plastic	1
17	WZX1505A	£12.25	KIT, gasket & seals	1

HIF6 Turbo Carburettor

FZX1435	£560.60	CARBURETTOR, turbo	1
---------	---------	--------------------	---

Twin Carburettor Kits

FZX3052	£759.20	TWIN CARBURETTOR KIT	1	HS2
		(Includes: Manifold, heat shields, carburettors, linkages etc, except air filters).		
AUD662T	£619.80	TWIN CARBURETTOR ONLY, (pair)	1	HS2
FZX3054	£795.60	TWIN CARBURETTOR KIT	1	HS4
		(Includes: Manifold, heat shields, carburettors, linkages etc, except air filters).		
12G292	£10.00	FUEL PIPE, twin carb	1	

Dash Pot Covers

HS4/6 Dash Pot Covers

SFR150	£11.50	COVER, dash pot	1	chrome
SFR23	£15.50	COVER, dash pot	1	polished
SFR23R	£18.10	COVER, dash pot	1	red anodised
SFR23B	£18.10	COVER, dash pot	1	blue anodised

HIF44/6 Dash Pot Covers

SFR175	£9.70	COVER, dash pot	1	chrome
SFR24	£15.50	COVER, dash pot	1	polished
SFR24R	£10.13	COVER, dash pot	1	red anodised
SFR24B	NCA	COVER, dash pot	1	blue anodised

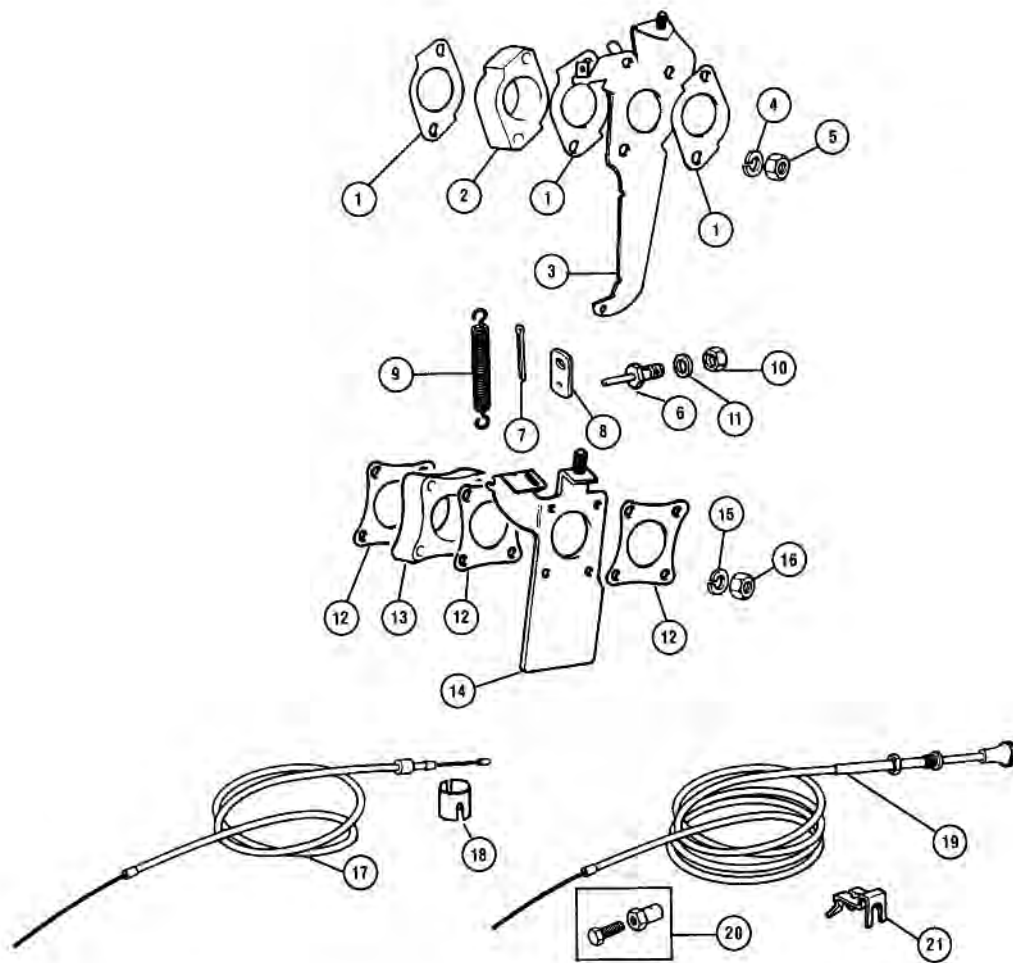

ill.	Part Number	Price £ea.	Description	Req.	Details
Carburettor Fixings					
1	AEC2083	£0.60	GASKET, carburettor to manifold	3	HS4 carburettors
2	12H1389	£18.10	SPACER, carburettor to manifold	1	
3	12G766	NCA	BRACKET, cable & spring	1	
4	GHF333	£0.28	WASHER, locking, carb. to manifold	2	
5	NT606041	£0.54	NUT, carburettor to manifold	2	
6	ACC5062	£1.90	LEVER PIN	1	
7	GHF502	£0.19	SPLIT PIN	1	
8	12A4	£1.85	TAG, return spring on lever	1	
9	21A839	£2.40	SPRING, throttle return	1	
	1E5537	£2.15	SPRING, throttle return	1	
10	GHF200	£0.19	NUT	1	
11	GHF300	£0.19	WASHER	1	
12	112867	£0.62	GASKET, carburettor to manifold	3	
13	112866	£3.49	SPACER, carburettor to manifold	1	
14	CAM4942	NCA	BRACKET, cable	1	
15	GHF332	£0.28	WASHER, locking	4	
16	NT605041	£0.28	NUT, carburettor to manifold	4	

ill.	Part Number	Price £ea.	Description	Req.	Details
	MCR104	£11.90	ACCELERATOR CABLE, RHD	1	1300cc Cooper SBB10099 alternative
	MCR104	£11.90	ACCELERATOR CABLE, RHD	1	
	SBB10126	£14.17	ACCELERATOR CABLE, LHD	1	
	SBB102510	£11.00	ACCELERATOR CABLE, RHD	1	1300cc Cooper late spi VIN 604847 On
	SBB103400	£21.70	ACCELERATOR CABLE, RHD	1	mpi 1996-On
	SBB103720	£68.00	ACCELERATOR CABLE, LHD	1	mpi 1996-On
	NNS10001	£96.30	SWITCH, ECU (Input, (ECU), electric control unit spi).	1	accelerator pedal switch
18	11H1172	£2.20	CLIP, cable to pedal	1	From VIN253000 To VIN303802
	DCP7342	£1.40	CLIP, cable to pedal	1	From VIN303803 On
19	21A1202	£19.50	CHOKE CABLE	1	Mkl and Mkl
	21A2329	£13.33	CHOKE CABLE	1	998cc To VIN278182
	MCR106	£19.63	CHOKE CABLE	1	998cc VIN278183 On
	MCR105	£13.60	CHOKE CABLE	1	Cooper 1300cc
	MCR105	£13.60	CHOKE CABLE	1	SBF10031 alternative
20	AUE34	£2.05	NIPPLE, cable end	1/2	quantity reduced for 998cc
21	516962A	£0.68	CLIP, choke cable to bracket	1	

Engine Controls

17	NAM7914	£6.00	ACCELERATOR CABLE	1	all 998cc models
	CAHT85	£6.10	ACCELERATOR CABLE (Nylon inner sleeved to create smoother action. 5 inches longer making it ideal for Weber fitment).	1	special tuning cable

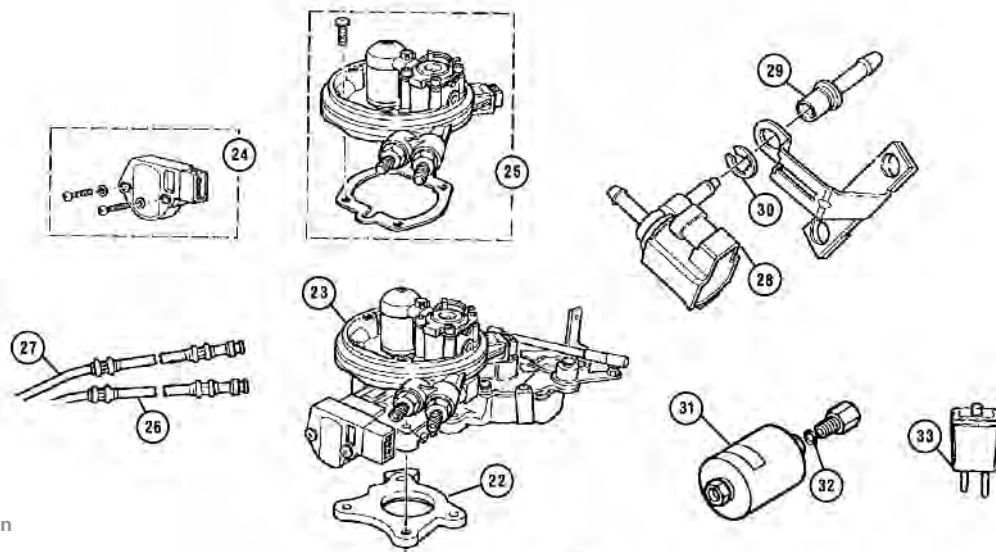

Single Point Injection

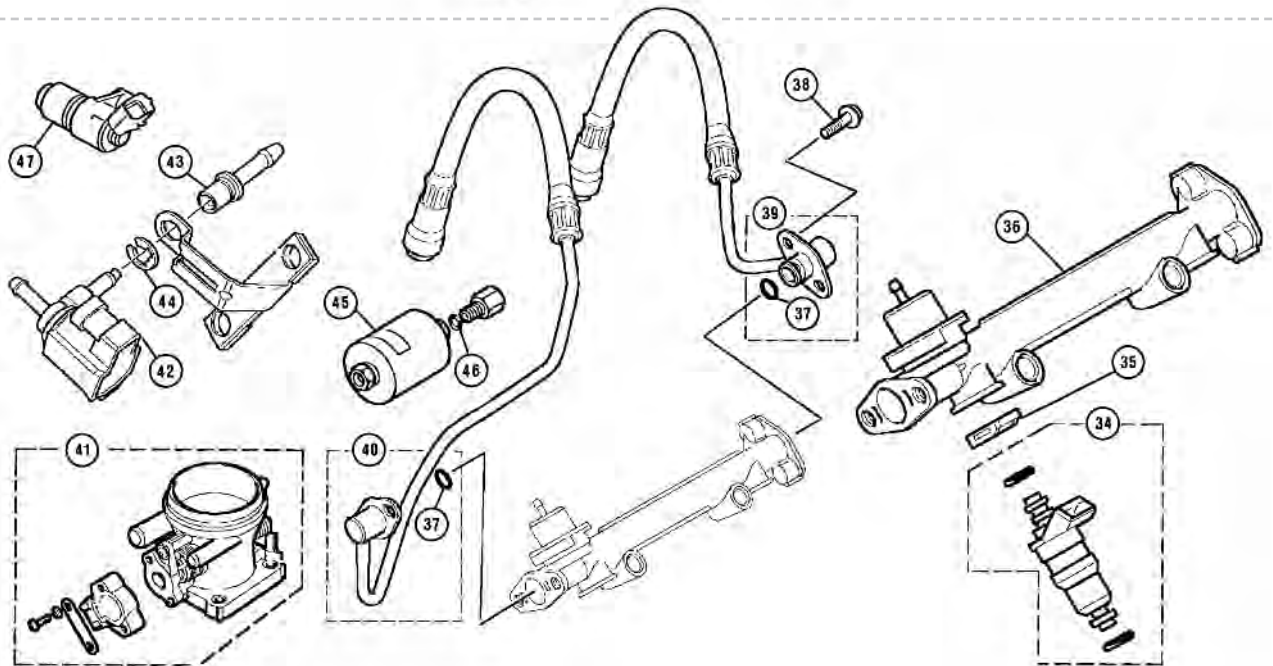

Multi Point Injection

ill.	Part Number	Price £ea.	Description	Req.	Details
Fuel Injection					
Single Point Injection					
22	LZV1101EVA	£17.30	SPACER, throttle body	1	
23	MLB10028	£425.40	THROTTLE BODY	1	spi includes injector
24	MMJ10003	£170.60	THROTTLE POTENTIOMETER	1	spi
25	MMJ10004	NCA	INJECTOR ASSEMBLY	1	spi
26	WJH104300	NCA	HOSE, fuel supply	1	
27	WJH104310	NCA	HOSE, fuel return	1	
28	AUU1503	NCA	PURGE VALVE	1	
29	JZV1223	NCA	TUBE, purge valve	1	
30	JZV1224	NCA	CLIP, tube	1	
31	GFE7059	£11.20	FILTER, fuel	1	
32	EDP9976	£2.20	SEAL	2	seal at fuel filter
33	NPC10001	£19.60	FUEL TRAP	1	
	NNS10001	£96.30	PEDAL SWITCH	1	

Multi Point Injection

34	MJY100460	£100.00	FUEL INJECTOR	2	mpi
----	-----------	---------	---------------	---	-----

ill.	Part Number	Price £ea.	Description	Req.	Details
35	MHN10004	NCA	CLIP, hold fuel injector	2	mpi
36	MJN100670	NCA	FUEL DELIVERY RAIL	1	mpi
37	BAU5325	£8.40	SEAL	2	mpi 'O' ring seal fuel delivery & return pipes to fuel rail
38	MYP100300	£1.60	BOLT	4	fuel hose to delivery rail
39	WJH103900	£55.70	HOSE, fuel supply	1	
40	WJH103910	£66.50	HOSE, fuel return	1	
41	MHB000480	£682.20	THROTTLE BODY, plastic	1	mpi 48mm
	MT3601	NCA	THROTTLE BODY, alloy	1	mpi replacement 48mm
	MT3602	NCA	THROTTLE BODY, alloy	1	mpi replacement 52mm
42	AUU1503	NCA	PURGE VALVE	1	
43	JZV1223	NCA	TUBE, purge valve	1	
44	JZV1224	NCA	CLIP, tube	1	
45	GFE7059	£11.20	FILTER, fuel	1	MPI 1997-98
	WJN101190	£10.40	FILTER, fuel	1	MPI 1998-On
46	EDP9976	£2.20	SEAL	2	seal at fuel filter
47	MHK100600	£130.00	SENSOR, manifold pressure	1	

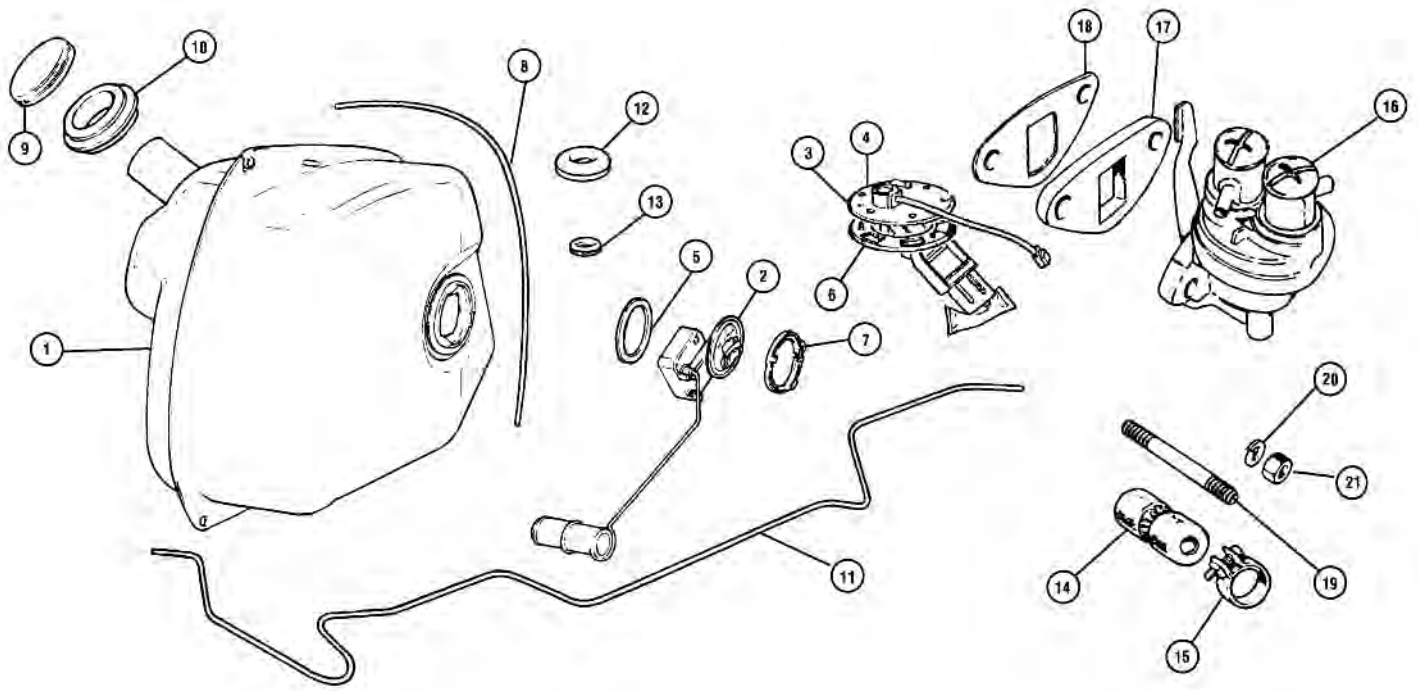

ill.	Part Number	Price £ea.	Description	Req.	Details
Fuel Tank and Pump					
Note: 5.5 gallon fuel tanks are no longer available. Use ARP1043 with 21A2838 strap.					
1	ARP1043	£274.00	FUEL TANK, 7.5 gallon	1	carburettor models
	WFE106090	£343.10	FUEL TANK, 7.5 gallon	1	injection models
	21A2838	£14.00	STRAP SUPPORT, fuel tank	1	7.5 gallon tank, diagonal fit
	2A2226	£9.00	STRAP SUPPORT, fuel tank, upper, long	1	5.5 gallon tanks, two piece retaining strap
	SH605181	£1.36	SCREW, strap to floor	1	
	346071A	£1.66	CAGED NUT, on boot floor bracket	1	
2	XNB10007	£21.20	SENDER UNIT, fuel tank	1	carburettor only
	XNB100380	£33.40	SENDER UNIT, fuel tank	1	injection only
3	WFX10045	NCA	FUEL PUMP	1	spi
4	WFX100810	£156.00	FUEL PUMP	1	mpi
	WFX100810Z	NCA	FUEL PUMP, alternative	1	
5	ARA1502	£2.47	SEAL, sender unit	1	
6	EDP9317	£35.00	SEAL, fuel pump	1	injection only
7	ARA1501	£1.20	RING, locking, sender unit	1	
8	GWW202M	£1.15	PIPE, tank vent	a/r	per metre
9	GSS154	£14.40	FUEL CAP, locking, vented	1	carburettor models
	GSS154Z	£12.00	FUEL CAP, locking, vented, slimline	1	
	WLD10027	£6.00	FUEL CAP, non locking, non vented	1	injection models
	WLD100310	£14.40	FUEL CAP, locking, non vented	1	
	21A2109	£3.32	SEAL, fuel cap	1	
10	14A7057	£7.30	SEAL, filler neck to body	1	
	2A2069	£1.36	SEAL, filler neck foam	1	alternative
11	MPKF225	£47.40	PIPE, fuel, tank to pump, kunifer	1	1/4" O/D x 25ft long
	21A2183	£390.00	FUEL TANK, right hand	1	Cooper S, 5.5 gal
	21A2185	NCA	FUEL TANK, right hand, alloy	1	Cooper S, 5.5 gal
	MT3121	£62.00	FITTING KIT, right hand tank	1	tank fitting kit
	GAC8436X	£18.00	FILLER NECK KIT	1	
	GAC8436Q2	£2.71	NECK SEAL	1	dummy seal for GAC8436X
	21A291	£245.00	FUEL TANK, van/estate/pickup	1	use only vented cap
	WLD10027	£6.00	FUEL CAP, non locking	1	vented
	21A2109	£3.32	SEAL, fuel cap	1	
	AAU8340	£31.40	SENDER UNIT	1	
	2H1082	£0.48	GASKET, sender unit	1	
	293-401	£8.00	GASKET SET, VITON	1	
	21A304	£1.96	NUT, large	3	fits at rear of tank
	AB614101	£1.00	SCREW, large	3	for 21A304
	21A305	£1.50	NUT, small	3	fits at rear of tank
	AB614061	£1.04	SCREW, small	3	for 21A305

Note: For the main feed pipe 4 metres is required. This can then be cut to the correct length.

CDU2283M	NCA	HOSE, fuel, rubber	a/r	per metre
----------	-----	--------------------	-----	-----------

Note: CDU2283M is only sold in metre lengths and must be cut to the following lengths: Tank to main

ill.	Part Number	Price £ea.	Description	Req.	Details
pipe 11", main pipe to pump 3", pump to pipe 3", pipe to carburettor 3".					
12	ACB8474	£1.36	GROMMET	1	fuel pipe through floor
13	RFN403	£1.60	GROMMET	1	tank vent pipe through floor
	WYA10001	£9.30	GROMMET, oval hole 2in fuel lines	1	MPI (Required also if a new body shell has been purchased).
14	GGT101	£2.23	HOSE, fuel, braided	a/r	2.5" long
	GGT102	£4.56	HOSE, fuel, braided	a/r	6.75" long
	GGT104	£5.60	HOSE, fuel, braided	a/r	10.0" long
	GGT105	£6.00	HOSE, fuel, braided	a/r	11.75" long
	GGT106	£6.00	HOSE, fuel, braided	a/r	14" long
15	GGT1117X	£1.50	CLIP, for braided hose	a/r	
16	AZX1818	£54.00	FUEL PUMP, mechanical	1	For all mechanical pumps
	AZX1818	£54.00	FUEL PUMP, mechanical, aftermarket	1	
	AZX1817	£54.00	FUEL PUMP, mechanical	1	Cooper 1990-91
17	GUG705603GM	£7.70	SPACER, pump to block	1	
18	GUG705779GM	£0.84	GASKET, mechanical pumps	2	
19	CHS2515	£1.36	STUD, for mechanical pump	2	
20	GHF332	£0.28	WASHER, locking	2	
21	GHF201	£0.12	NUT	2	
	AUF214	£81.00	FUEL PUMP, electric	1	point type To 1970
	AUF214Z	£57.00	FUEL PUMP, electric, aftermarket	1	point type To 1970
	AUB6106A	£12.60	CONTACT SET	1	
	AUB663	£5.10	BANJO	2	
	AUB676	£0.62	SEALING WASHER	a/r	
	AUB617	£4.56	FILTER	1	
	WZX1701	£12.00	VALVE KIT	1	

Interrupter Fuel Pump Kits

Note: These pumps can be mounted either at the front or rear of the car.

TMG2930K	£114.40	FUEL PUMP KIT, negative earth	1	18 gal/hr flow 4.0 psi
TMG2930P	£76.70	FUEL PUMP KIT, positive earth	1	18 gal/hr flow 4.0 psi
MGS2930K	£119.60	FUEL PUMP KIT, negative earth	1	25 gal/hr flow 5.0 psi
TT2930	£103.00	FUEL PUMP KIT, negative earth	1	38 gal/hr flow 6.5-7.0 psi

Solid State Fuel Pump Kits

Note: These pumps are required to be fitted within 12 inches of the fuel supply (tank) and below the fuel outlet because they rely on a gravity feed.

TMG2931K	£61.40	FUEL PUMP KIT, negative earth	1	18 gal/hr flow 4.0-5.5 psi
MGS2931	£43.70	FUEL PUMP KIT, negative earth	1	25 gal/hr flow 6.0- 7.0 psi

Note: We recommend that you fit an in line pressure regulator/filter.

TT2927	£75.90	FILTER/REGULATOR (67mm deep glass bowl, 6mm unions).	1	road, competition
--------	--------	--	---	-------------------

ill.	Part Number	Price £ea.	Description	Req.	Details
	C41220AX	£36.30	INERTIA SWITCH KIT (Cuts electrical supply to pump).	1	inline switch

Fuel Pump Unions

				Pipe	Thread
FPA903B	£1.92	UNION, straight	a/r	1/4 (6mm)	1/8 npt
MOC1604	£3.64	UNION, straight	a/r	5/16 (8mm)	1/8 npt
FPA904/B	£3.07	UNION, straight	a/r	3/8 (10mm)	1/8 npt
MOC1841	£6.14	UNION, 90°	a/r	5/16 (8mm)	1/8 npt
TT2930A	£13.20	UNION, 90°, (pair)	a/r	5/16 (8mm)	1/4 npt
FPA902B	£12.20	UNION, 90°, (pair)	a/r	3/8 (10mm)	1/4 npt

ill.	Part Number	Price £ea.	Description	Req.	Details
------	-------------	------------	-------------	------	---------

Fuel Filter/Regulators & Unions

Note: We recommend fitting an in line pressure regulator/filter with uprated fuel pumps. Also see Accessories.

				Pipe	Thread
TT29321	£8.64	UNION, (pair)	a/r	1/4 (6mm)	1/8 npt
TT2927	£75.90	FILTER/REGULATOR (67mm deep glass bowl, 6mm unions).	1	road/competition	
C41220AX	£36.30	INERTIA SWITCH KIT (Cuts electrical supply to pump).	1	inline switch	
PRO804	£10.80	IN LINE FILTER, chrome/glass	1		
PRO895	£1.00	SEAL, in-line fuel filter	1		
PRO896	£5.12	ELEMENT, filter pack	1	Pack of 3	

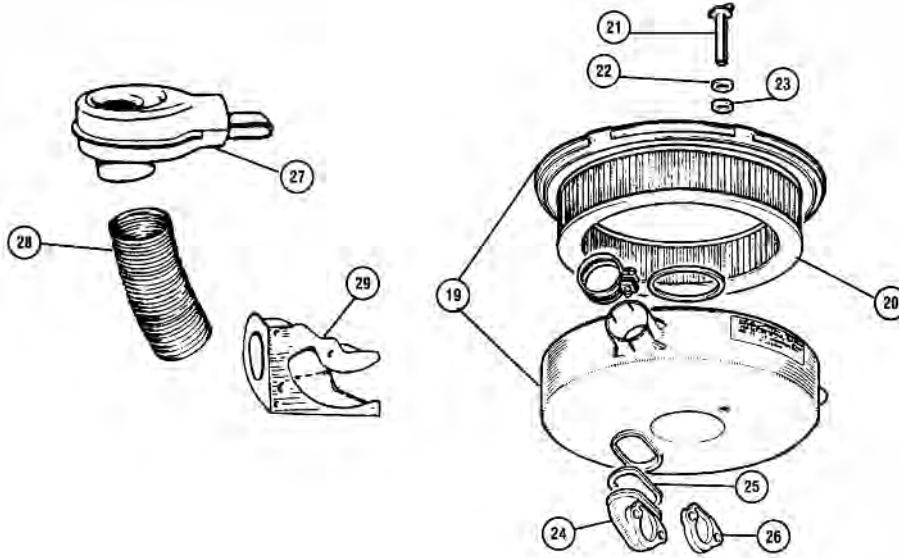

ill.	Part Number	Price £ea.	Description	Req.	Details
------	-------------	------------	-------------	------	---------

Air Filters

19	12G4298	NCA	AIR FILTER ASSEMBLY	1	998cc non servo
20	GFE1002	£7.00	ELEMENT, air filter	1	all 850cc models
	GFE1008	£6.50	ELEMENT, air filter	1	all 998cc models
	GFE1096	£4.30	ELEMENT, air filter	1	Cooper 1300cc + SE
	GFE1143	£12.40	ELEMENT, air filter	1	injection spi and mpi
21	12G1811	NCA	WING NUT, filter casing	2	
22	12A1436	£0.94	WASHER, steel	2	
23	12A1437	£0.62	WASHER, fibre	2	
24	12G1812	NCA	ELBOW, filter case to carburettor	1	all 998cc models
	CAM4694	NCA	ELBOW, filter case to carburettor	1	Cooper 1300cc + SE
25	12A1433	£2.00	SEAL, elbow to filter seal	1	
26	12G2125	£0.37	GASKET, elbow to carburettor	1	all 998cc models
	GUG705576GM	£1.04	GASKET, elbow to carburettor	1	Cooper 1300cc + SE
27	12G3210	£22.60	CONTROL, air temperature	1	all 998cc models
28	12H4344	£3.50	HOSE, (cut to length)	1	998cc non servo and Cooper
	LKM10002	NCA	HOSE, (cut to length)	1	998cc direct servo
29	12G3213	NCA	DUCT, warm air	1	998cc non servo
	TAM2149	NCA	DUCT, warm air	1	998cc direct servo
	CAM6767	NCA	DUCT, warm air	1	Cooper 1300/1275cc

K&N Air Filters

Replacement Elements

Note: These filters fit inside the standard air filter case.

KNE2601	£46.20	K&N ELEMENT, air filter	1	HS4 and HIF38
KNE9172	£48.60	K&N ELEMENT, air filter	1	injection cars, spi and mpi

Bolt-On Air Filters

Note: These filters replace the air filter and elbow, bolts directly to carburettor.

KN56-9128	£87.50	AIR FILTER	1	HS4 1-1/2" SU
-----------	--------	------------	---	---------------

ill.	Part Number	Price £ea.	Description	Req.	Details
	KN56-9142	£90.50	AIR FILTER, oval (7" wide x 5" high x 1-3/4" deep).	1	HS6 1-3/4" SU with offset hole
	KN56-9320	£102.00	AIR FILTER, tapered	1	HS4 1-1/2" SU
	KN56-9327	£110.00	AIR FILTER, tapered	1	HS6 1-3/4" SU
	KN56-9330	£110.20	AIR FILTER, tapered	1	HIF6/44 1-3/4" SU
	KN62-1010	£29.20	BREATHER FILTER	a/r	1/2" inlet
	KN62-1330	£24.00	BREATHER FILTER	a/r	1/2" inlet
	KN99-0621	£12.30	CLEANING FLUID, 1ltr	a/r	
	KN99-11312	£5.17	FILTER OIL, sachet, 14ml	a/r	
	KN99-0533	£6.35	FILTER OIL, 250ml	a/r	
	KN99-0516	£10.80	FILTER OIL, aerosol, 335ml	a/r	

57i Induction Kits

Note: These kits replace the air filter case and are supplied with cold air ducting.

KN57-0082	£93.20	57i INDUCTION KIT	1	spi models
KN57-0189	£136.60	57i INDUCTION KIT	1	mpi models

Stub Stacks

HS4 Stub Stacks

SFR430	£27.40	STUB STACK, 30mm	1	silver polished
SFR430R	NCA	STUB STACK, 30mm	1	red anodised
SFR430B	NCA	STUB STACK, 30mm	1	blue anodised
SFR2	£17.50	STUB STACK, short	1	period style
SFR8	£17.50	STUB STACK, long	1	period style

HS6 Stub Stacks

SFR650	£27.40	STUB STACK	1	silver polished
SFR650R	NCA	STUB STACK	1	red anodised
SFR650B	NCA	STUB STACK	1	blue anodised
SFR3	£17.50	STUB STACK, short	1	period style
SFR9	£17.50	STUB STACK, long	1	period style

HIF SU's Stub Stacks

SFR4430	£29.30	STUB STACK	1	silver polished
SFR4430B	£24.90	STUB STACK	1	blue anodised

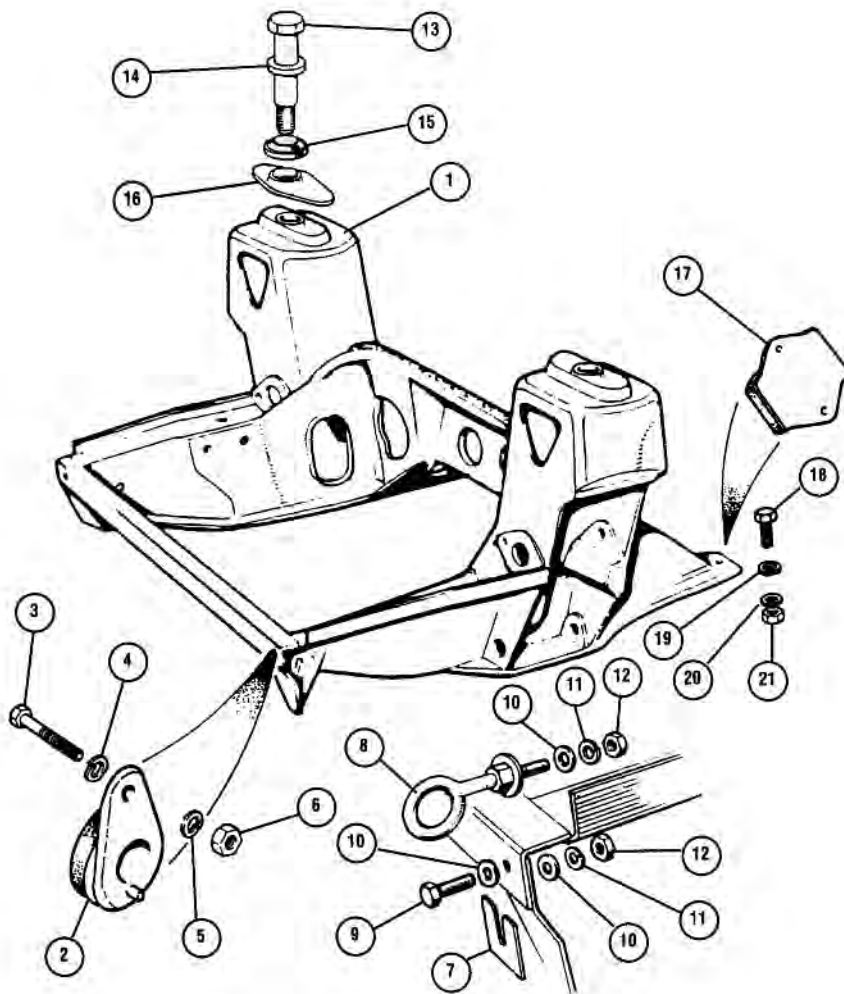

ill.	Part Number	Price £ea.	Description	Req.	Details
Front Subframe					
1	21A2570	£500.00	FRONT SUBFRAME, BMH	1	1969-75
	KGB10022	£471.20	FRONT SUBFRAME, BMH	1	1976-92, 998cc
	KGB10027	£471.20	FRONT SUBFRAME, BMH	1	1991-96, 1275cc
	KGB100500	£471.20	FRONT SUBFRAME, BMH	1	1997-On
	KGB10024	£471.20	FRONT SUBFRAME, BMH	1	1976-On, Automatic
	HMP241001	£1,980.00	ASSEMBLED FRONT SUBFRAME, BMH	1	1976-96 (Includes full suspension, brakes, hubs & drive shafts).
	HMP241003	£1,980.00	ASSEMBLED FRONT SUBFRAME, BMH	1	1997-On (Includes full suspension, brakes, hubs & drive shafts).
2	21A2624	£12.00	FRONT MOUNTING, teardrop, OE	2	
	21A2624Z	£3.80	FRONT MOUNTING, teardrop	2	aftermarket
	21A2624X	£28.70	FRONT MOUNTING, teardrop, (single)	2	blue anodised machined billet alloy
	CSTR641	£20.00	FRONT MOUNTING, teardrop, (pair)	1	cast alloy
Note: See the Accessories section for more polyurethane and solid subframe mounting options.					
3	GHF103	£0.54	SCREW, mounting to valance	2	
4	GHF332	£0.28	WASHER, locking	2	
5	GHF301	£0.22	WASHER	2	
6	FNZ505	£0.68	NUT	2	
7	2A4292	£9.60	PACKING	a/r	
			(Subframe to front valance standard fitment 96 on required when fitting 13 inch wheels or 165/60/12 tyres to 4.5 + wide wheels to space the front panel slightly forward).		
8	21A1241	£9.60	EYE BOLT	2	alternatives

ill.	Part Number	Price £ea.	Description	Req.	Details
	KPU100160	NCA	EYE NUT, towing eye	2	female fitment
9	GHF105	£0.37	BOLT	2	alternatives
10	GHF302	£0.60	WASHER, plain	2	
11	GHF333	£0.28	WASHER, locking	2	
12	FNZ506	£0.62	NUT	2	
13	21A2596	NCA	BOLT, subframe tower mounting	2	
14	53K3755	£1.20	WASHER	2	
15	KGE100050	£3.92	BUSH, bolt to crossmember	2	
	KGE100050SP	£6.35	BUSH, bolt to crossmember, polyurethane	2	
	KAD1013297	£17.30	BUSH, alloy, bolt to crossmember	2	solid subframe mounting
	CSTR640	£19.20	BUSH KIT, alloy kit, set of 4	1	solid tower mount kit (Replaces both top and bottom pads between cross member and subframe).
16	KGE100060	£6.00	PAD, subframe to body, rubber	2	
	KGE100060SPK	£39.50	PAD KIT, subframe to body, poly	1	(Kit includes: 2 tower mounting pads & 2 tower bolt washers).
17	21A2599Z	£3.58	REAR MOUNTING	2	
	CSTR642	£20.00	REAR MOUNTING, (pair)	1	solid steel subframe mount (Eliminates front subframe movement).
18	SH605061	£0.19	SCREW	8	Mounting to toe board and subframe
19	WC108051	£0.28	WASHER, plain	8	
20	GHF332	£0.28	WASHER, locking	12	
21	GHF201	£0.12	NUT	8	

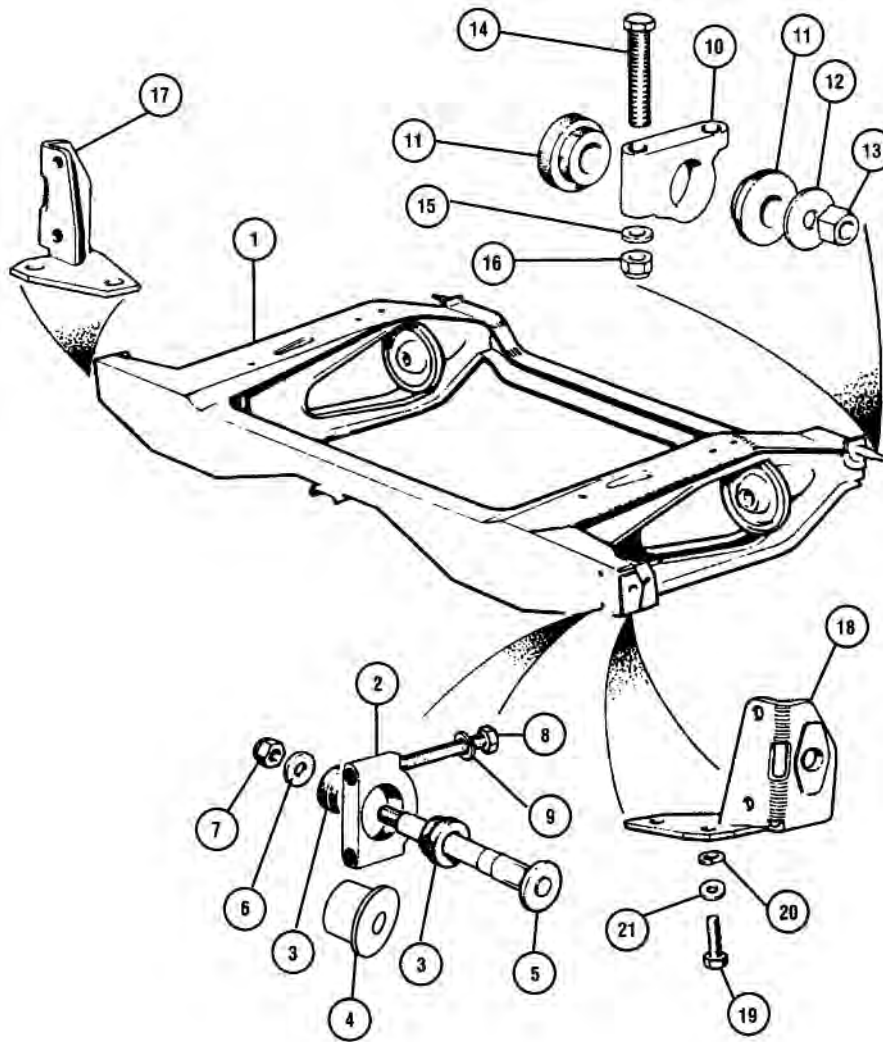

Part Number	Price £ea.	Description	Req.	Details
Rear Subframe				
1 KHB10026	NCA	REAR SUBFRAME, BMH (Hook/rod type exhaust hangers. With mounting trunnions).	1	1959-97 pre-injection, dry
FAM6292	NCA	REAR SUBFRAME, BMH (Bolt-on/cotton reel exhaust hangers).	1	1959-91
FAM6292Z	NCA	REAR SUBFRAME, aftermarket (Bolt-on/cotton reel exhaust hangers).	1	pre-injection, dry
FAM6292A	NCA	REAR SUBFRAME, BMH, Hi-Lo (Bolt-on/cotton reel exhaust hangers).	1	1959-91 pre-injection, dry
KHB10024	NCA	REAR SUBFRAME, BMH (Includes rods for rubber exhaust mountings).	1	1992-On
KHB10023	NCA	REAR SUBFRAME, BMH (Hook/rod type exhaust hangers. Without mounting trunnions)	1	Germany
KHB100590	NCA	REAR SUBFRAME, BMH (Hook/rod type exhaust hangers).	1	13" Wheels (Silverstone, Sportpack & Cooper.
21A2160	NCA	REAR SUBFRAME, BMH (Not Cooper or Cooper S)	1	1964-71 hydrolastic
HMP241002	NCA	ASSEMBLED REAR SUBFRAME, BMH (Hook/rod type exhaust hangers. Includes full suspension, brakes & hubs).	1	1976-On
2 2A5819	£36.00	TRUNNION, stepped, front mount	2	To 1976
21A2558	£36.00	TRUNNION, front mount	2	1976-On
3 2A5818	£1.36	MOUNTING BUSH, split type, rubber	4	To 1976
2A5818SPK	£16.94	MOUNTING BUSH KIT, split type, poly (Kit includes: 4 bushes for one pair of trunnions).	1	front mount

Note: In 1976 the rear subframe were changed to a large single bush on the front mounting and the small split bushes kept on the rear mountings. The large bushes are used with 21A2558 trunnion. Note: see the Accessories section for more polyurethane and solid subframe mountings.

Part Number	Price £ea.	Description	Req.	Details
4 21A2560	£5.00	MOUNTING BUSH, large, rubber	2	1976-On
21A2560SPK	£17.75	MOUNTING BUSH KIT, large, poly (Kit includes: 2 bushes for one pair of trunnions).	1	front mount
5 21A1440	£20.00	SUPPORT PIN, front mounting	2	
6 PWZ207	£0.73	WASHER, plain	4	
7 LNZ207	£1.04	NUT, nyloc	4	
8 BH605101	£0.79	BOLT, front trunnion, short	2	To 1976
BH605201	£1.20	BOLT, front trunnion, long	2	To 1976
BH605201	£1.20	BOLT, front trunnion, long	4	1976-On
9 GHF332	£0.28	WASHER, locking	4	
10 2A5819	£36.00	TRUNNION, stepped	2	To 1976
11 2A5818	£1.36	MOUNTING BUSH, split type, rubber	4	all models
2A5818SPK	£16.94	MOUNTING BUSH KIT, split type, poly (Kit includes: 4 bushes for one pair of trunnions).	1	rear mount
12 PWZ207	£0.73	WASHER, plain	4	
13 LNZ207	£1.04	NUT, nyloc	4	
14 BH605101	£0.79	BOLT, rear trunnion, short	2	
BH605201	£1.20	BOLT, rear trunnion, long	2	
15 GHF301	£0.22	WASHER	4	
16 GHF222	£0.62	NUT, nyloc	4	
17 21A195	£20.80	BRACKET, radius arm RH	1	
18 21A197	£20.80	BRACKET, radius arm LH	1	
WPT90021	£39.60	BRACKETS, radius arms, (pair)	1	adjustable camber
WPT9002X	£30.00	BRACKETS, radius arms, (pair)	1	+ 1.5° extra -ve camber
19 GHF120	£0.28	SCREW, bracket to rear subframe	8	
20 GHF332	£0.28	WASHER, locking	8	
21 GHF301	£0.22	WASHER	8	

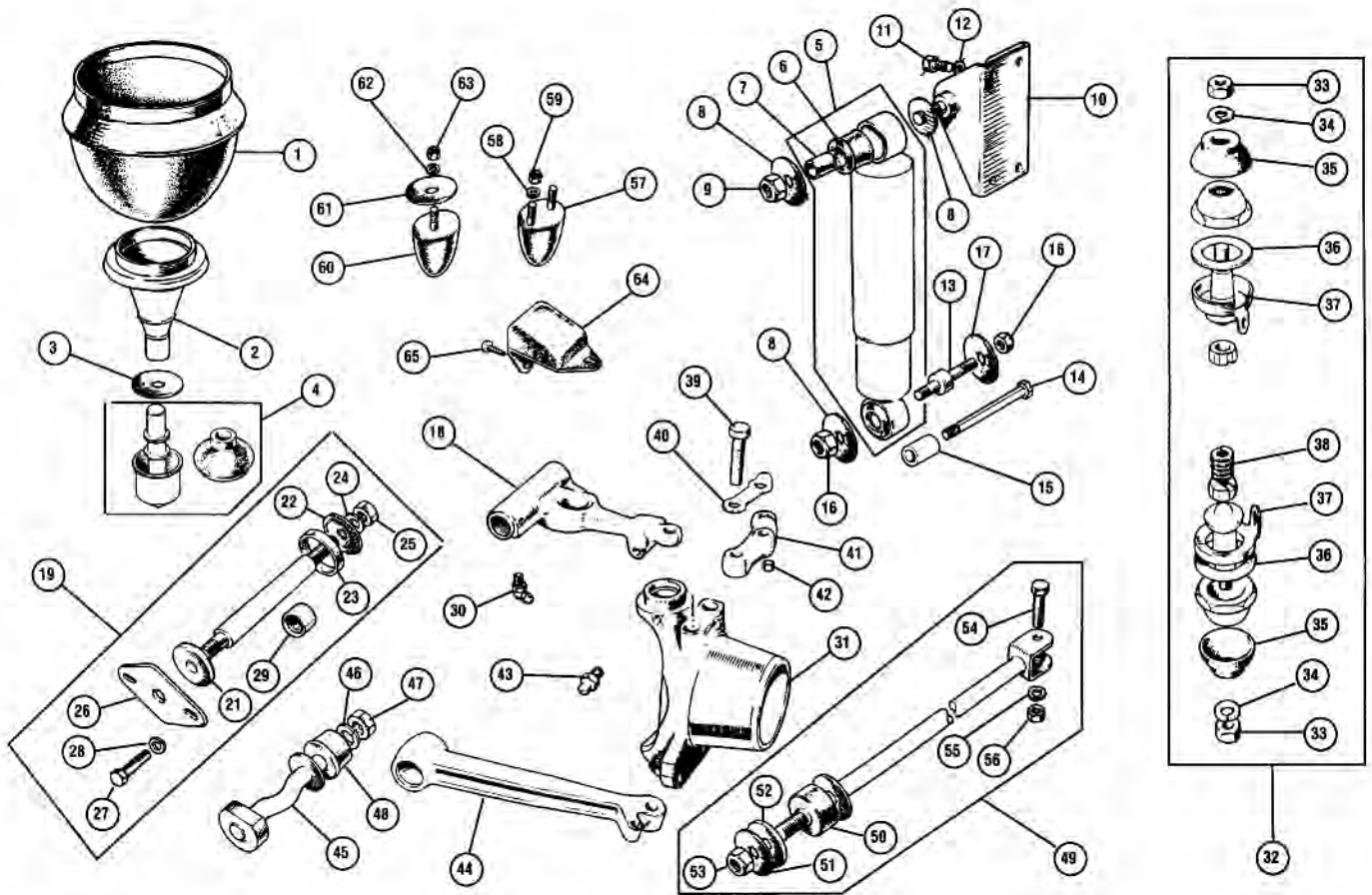

Ill.	Part Number	Price £ea.	Description	Req.	Details
Front Suspension (Dry)					
1	FAM3968	£56.00	RUBBER CONE, standard, metric thread	2	genuine Rover
	FAM3968RX	£68.00	RUBBER CONE, uprated, metric thread	2	use with Hi-Lo kit
	FAM3968X	£420.00	COIL SPRING KIT, blue	1	softer, front and rear spring kit, replaces rubber cone
	FAM3968HX	£360.00	COIL SPRING KIT, red	1	firmer, front and rear spring kit, replaces rubber cone
2	21A530	£39.00	STRUT	2	
	GAC8437X	£128.11	HI-LO, suspension kit	1	adjustable height kit front and rear
	GAC84371	£55.00	HI-LO TRUMPET (Inc: 2 x Hi-lo cones and 2 x 21A423).	1	adjustable height cones kit
	GAC84374	£7.00	ALLEN BAR, front	1	adjustable suspension heights
	GAC8432X	£61.80	ADJUSTA-RIDE, suspension kit	1	adjustable height kit front
3	21A1845	£3.74	WASHER, packing (Cars with 12" wheels require 1 packing washer per side).	a/r	to raise ride height
4	GSV1118	£3.18	KNUCKLE JOINT	2	
	21A423	£1.15	CUP	2	suspension knuckle cup
	21A425	£0.90	GAITER	2	suspension knuckle gaiter
5	GSA71541	£15.60	SHOCK ABSORBER	2	
	GAC84011XPR	£139.70	SHOCK ABSORBER, Spax, pair	2	standard height
	GAC84021XPR	£139.70	SHOCK ABSORBER, Spax, pair	2	lowered height
	GAC8401XG	£55.00	SHOCK ABSORBER, Gaz	2	standard height
	GAC8402XG	£57.20	SHOCK ABSORBER, Gaz	2	lowered height
	MT1302	£29.30	SHOCK ABSORBER, Gmax	2	30% uprated
	SPCK19	£641.70	SHOCK ABSORBER KIT, Spax (Adjustable ride height for front and rear).	1	coil over kit, standard height
	SPCK20	£641.70	SHOCK ABSORBER KIT, Spax (Adjustable ride height for front and rear).	1	coil over kit, lowered height
6	21A1230	£1.36	BUSH, shock absorber	4	
7	21A504	£2.81	SLEEVE	4	shock absorber
8	AJD7162	£0.42	WASHER	8	bush
9	GHF223	£0.48	NUT, nyloc	2	top mount
10	21A471	£24.00	MOUNTING, RH	1	shock absorber
	21A474	£24.00	MOUNTING, LH	1	top
11	GHF117	£0.28	SCREW, bracket to inner wing	8	
12	GHF331	£0.17	WASHER, locking	8	
13	2A4337	NCA	PIN, lower shock absorber mount	2	
14	BH606321	£1.62	BOLT, lower shock absorber mount	2	alternatives to
15	21A2694	£3.00	SPACER, (use with BH606321)	2	item 13
16	GHF223	£0.48	NUT, nyloc (Quantity reduced when item 14, (BH606321) is used).	4/2	
17	GHF302	£0.60	WASHER	2	
18	21A2690	£223.00	UPPER ARM, RH	1	
	21A2691	£223.00	UPPER ARM, LH	1	
19	2A4325K	£15.60	REPAIR KIT, top fulcrum shaft	2	
21	2A4326	£3.49	THRUST COLLAR	2	
22	2A7324	£3.00	THRUST WASHER	2	
23	2A7327	£0.60	SEAL, rubber ring on top arm	4	
	115702SP	£2.26	SEAL, polyurethane	4	alternative
24	GHF335	£0.32	WASHER, locking, shaft end	4	
25	FNZ508	£1.42	NUT, shaft end	4	
26	2A4327	£6.66	PLATE, shaft retaining	2	
27	SH604051	£0.28	SCREW, plate retaining	4	
28	GHF331	£0.17	WASHER, locking	4	
29	88G302	£5.30	NEEDLE ROLLER, top arm	4	
30	UHN445	£1.45	GREASE NIPPLE, top arm	2	
31	21A371	£70.70	HUB CARRIER, RH	1	drum brakes
	21A372	NCA	HUB CARRIER, LH	1	
	FAM2390	£70.00	HUB CARRIER, RH	1	disc brakes
	FAM2391	£57.60	HUB CARRIER, LH	1	
32	GSJ166	£8.10	SWIVEL PIN KIT, (per side)	2	
	GSJ166SK	£1.36	SHIM KIT, swivel pin, (per side)	2	
33	FNZ507	£0.79	NUT, high tensile	4	
34	GHF334	£0.37	WASHER, locking	4	
35	BTA377	£1.04	DUST COVER	4	
36	2A4240	NCA	SHIM, 0.005" (0.127mm)	a/r	
37	2A4238	£1.90	LOCKTAB	4	
38	21A370	NCA	SPRING	2	
39	2A4315	£4.44	BOLT, steering arm to hub carrier	4	
40	2K5377	£1.66	LOCKTAB, steering arm	2	
41	BTA896	NCA	STEERING ARM, RH	1	
	BTA897	£47.30	STEERING ARM, LH	1	
	BTA894	£19.50	STEERING ARM, RH	1	Cooper S
	BTA895	£19.50	STEERING ARM, LH	1	Cooper S
42	FAM6924	£4.44	DOWL, steering arm locating	4	
43	UHN400	£0.73	GREASE NIPPLE, swivel pin	4	

Ill.	Part Number	Price £ea.	Description	Req.	Details
44	21A1879	£39.00	LOWER ARM, RH	1	
	21A1881	£39.00	LOWER ARM, LH	1	
	WPT9001X	£60.00	LOWER ARMS, negative camber	1	
	C-AJJ3363	£114.00	LOWER ARMS, adjustable (1 piece, forged, spherical-jointed rod end, adjustable lower arms (with joint) to allow adjustment for camber. Heat tested and crack tested).	1	sold in pairs
45	2A4362	£18.00	FULCRUM PIN, lower	2	
46	GHF333	£0.28	WASHER, locking	2	
47	FNZ506	£0.62	NUT	2	
48	2A4294	NCA	BUSH, lower arm, straight hole	4	1959-65
	21A1882	£1.32	BUSH, lower arm, tapered hole	4	1966-On
	21A1882SPK	£19.90	BUSH KIT, lower arm, polyurethane (Kit includes: 2 bushes & 2 tubes).	1	
49	21A450	£8.90	TIE BAR	2	
	8G4249	£14.20	TIE BAR & BUSH SET	2	per side
	WPT9003X	£27.40	TIE BAR SET, heavy duty, pair (This set does not include bushes).	1	
50	31G1155	£0.68	BUSH, tie bar end, rubber	4	
	31G1155H	£2.23	BUSH, tie bar end, rubber	4	harder road spec
	31G1155VH	£2.47	BUSH, tie bar end, rubber	4	harder race spec
	31G1155SPK	£14.40	BUSH KIT, tie bar end, polyurethane (Kit includes: 4 bushes).	1	
51	PWZ207	£0.73	WASHER, tie bar end	2	
52	2A4328	£1.30	WASHER, cup tie bar end	2	
	ACA9759	£1.85	WASHER SET, front tie bar	2	contains items 51 and 52
53	GHF224	£0.62	NUT, nyloc tie bar end	2	
54	53K1031	£1.66	BOLT, tie bar to lower arm	2	
55	GHF332	£0.28	WASHER, locking	2	
56	FNZ505	£0.68	NUT	2	
57	2A4332	£6.20	BUMP STOP, 2 stud fixing	2	To 1975
58	GHF331	£0.17	WASHER, locking	4	
59	GHF200	£0.19	NUT	4	
	21A1598	£14.00	REBOUND BUFFER	2	fit hydro suspension cars fitted to top arm
60	FAM2764	£5.66	BUMP STOP, 1 stud fixing	2	1976-On
61	FAM2767	£4.27	PACKING, bump stop	2	12" wheel models only
62	GHF331	£0.17	WASHER, locking	2	
63	GHF200	£0.19	NUT	2	
64	2A4267	£3.38	BUFFER, rebound	2	
	2A4267P	NCA	BUFFER, rebound	2	polyurethane
65	PMZ308	£0.28	SCREW, buffer retaining	4	
	MTR4201	£37.10	GAUGE, camber (This gauge allows you to correctly set up your suspension to get the best from your Mini where it excels most, the corners).	1	
	MT9600	£29.10	CONE COMPRESSOR	1	metric cones only
	GAC9424X	£79.90	CONE COMPRESSOR	1	metric and imperial cones

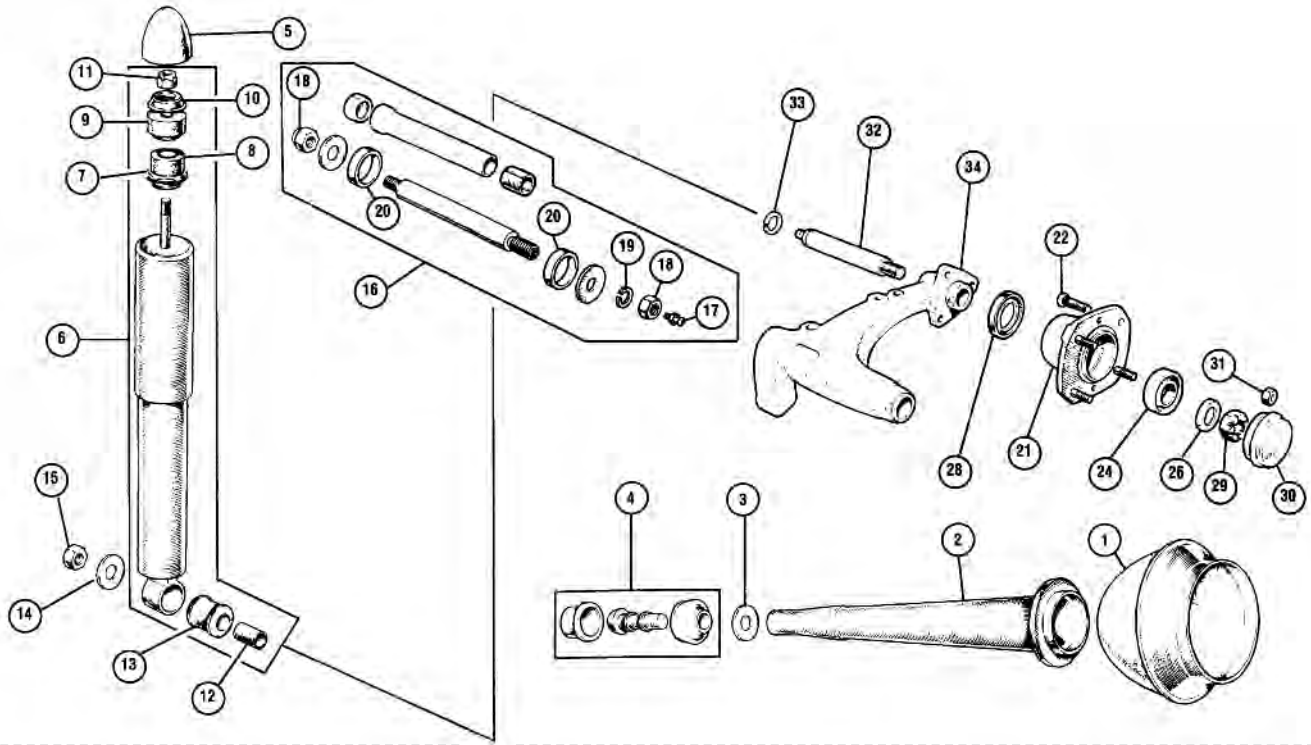

ill.	Part Number	Price £ea.	Description	Req.	Details
Rear Suspension (Dry)					
1	FAM3968	£56.00	RUBBER CONE, standard, metric thread	2	genuine Rover
	FAM3968RX	£68.00	RUBBER CONE, uprated, metric thread	2	use with Hi-Lo kit
	FAM3968X	£420.00	COIL SPRING KIT, blue	1	softer
	FAM3968HX	£360.00	COIL SPRING KIT, red	1	firmer
			(Front and rear coil spring kit that replaces the rubber cone).		
			(Front and rear coil spring kit that replaces the rubber cone).		
2	21A1684	£110.00	STRUT	2	
	GAC8437X	£128.11	HI-LO, suspension kit	1	adjust height kit front and rear
	GAC84371	£55.00	HI-LO TRUMPET	1	adjustable height cones kit
	GAC84372	£15.00	RODS, extension, (pair)	1	used with GAC84371 when fitting to rear suspension
	GAC84373	£7.50	ALLEN BAR, rear	1	adjusting suspension height
	GAC8433X	£111.70	ADJUSTA-RIDE, suspension kit	1	adjustable height kit rear
3	21A1845	£3.74	WASHER	a/r	packing to raise ride height
4	GSV1118	£3.18	KNUCKLE JOINT	2	
	21A423	£1.15	CUP	2	suspension knuckle
	21A425	£0.90	GAITER	2	suspension knuckle
5	21A640	NCA	COVER, top shock absorber mounting	2	
6	GSA71542	£13.20	SHOCK ABSORBER	2	
	GAC84031XPR	£139.70	SHOCK ABSORBER, Spax, pair	1	standard height
	GAC84041XPR	£139.70	SHOCK ABSORBER, Spax, pair	1	lowered height
	GAC8403XG	£55.00	SHOCK ABSORBER, Gaz, each	2	standard height
	GAC8404XG	£57.20	SHOCK ABSORBER, Gaz, each	2	lowered height
	GAC8408XPR	NCA	SHOCK ABSORBER, Koni, pair	1	lowered height
	SPCK19	£641.70	SHOCK ABSORBER KIT, Spax	1	coil over kit (Height adjustable front and rear kit standard height).
	SPCK20	£641.70	SHOCK ABSORBER KIT, Spax	1	coil over kit (Height adjustable front and rear kit lowered height).
7	517984	£1.40	WASHER, lower bush retaining	2	
8	517985	£1.25	BUSH, lower top, s/absorber	2	
9	C2542	£5.00	BUSH, upper top, s/absorber	2	
10	517984	£1.40	WASHER, upper bush retaining	2	
11	GHF273	£0.37	NUT, nyloc, top s/absorber mount	2	
12	21A504	£2.81	SLEEVE, bottom s/absorber bush	2	
13	21A1230	£1.36	BUSH, bottom s/absorber mounting	2	
14	AJD7162	£0.42	WASHER	2	
15	GHF223	£0.48	NUT, nyloc	2	
16	GSV1125	£12.00	REPAIR KIT	2	radius arm fulcrum pin

Note: GSV1125 requires a special tool for reaming after installation of the bearings. The special reamer 18G588 is NCA. However reconditioned and new radius arms are available. See below.

	ACA9099	£8.60	SHAFT, radius arm	2	
	17 UHN400	£0.73	GREASE NIPPLE, fulcrum pin	2	
	18 FNZ508	£1.42	NUT, fulcrum pin	4	

ill.	Part Number	Price £ea.	Description	Req.	Details
	19 GHF335	£0.32	WASHER, locking	4	
	20 2A7327	£0.60	SEAL, radius arm	4	
	115702SP	£2.26	SEAL, poly version of 2A7327	4	

Rear Hub & Stub Axle

21	21A2023	£33.20	HUB, with short studs	2	10" wheels To 1984
	RLH10021	NCA	HUB, with long studs	2	12" wheels 1984-On
	21A2023XR	NCA	HUB, alloy, with long studs, red	2	includes bearings
	21A2023XB	£100.13	HUB, alloy, with long studs, blue	2	includes bearings
22	21A2064	£1.36	WHEEL STUD, short	8	10" wheels To 1984
	RLJ10001	£1.42	WHEEL STUD, long	8	12" wheels 1984-On
23	GHK1548	£12.50	HUB BEARING KIT, taper roller type	2	heavy duty
26	BTA672	£3.32	WASHER, hub	2	
28	GHS227	£1.50	SEAL, grease	2	all models
29	51K328	£2.90	NUT, RH hub	1	
	FNN2410	£5.05	NUT, LH hub	1	
30	ATB4098	£6.70	GREASE CAP	2	
31	88G322	£0.79	WHEEL NUT, round chamfer	16	standard 10" wheels
	113087	£1.32	WHEEL NUT, 60° chamfer angle	16	standard 12" wheels
	FAM5701	£8.30	WHEEL NUT, round chamfer*	16	10" with hub caps
	FAM3428	NCA	WHEEL NUT, 60° chamfer*	16	12" with hub caps
	RRD10009	£3.74	WHEEL NUT, 60° chamfer	16	Rover alloy wheels (Feature a loose washer and stainless cap).

*Note: If your car is fitted with wheel trims retained by the wheel nuts, you will require wheel nuts marked with an asterisk. Care must be taken when ordering as 'radius' and 'chamfered' wheel nuts are not interchangeable!

32	2A7351	£29.00	STUB AXLE, RH, rear	1	
	2A7364	£29.00	STUB AXLE, LH, rear	1	
33	2A7352	£5.00	CIRCLIP, stub axle retaining	2	
34	NAM7162	£282.00	RADIUS ARM, RH, new	1	
	NAM7162N	£222.00	RADIUS ARM, RH, new, loaded	1	(Supplied with bearing, reamed bush, shaft and seals).
	NAM7162R	£64.00	RADIUS ARM, RH, reconditioned	1	(Refundable surcharge on this item - old unit required).
	NAM7163	£282.00	RADIUS ARM, LH, new	1	
	NAM7163N	£222.00	RADIUS ARM, LH, new, loaded	1	(Supplied with bearing, reamed bush, shaft and seals).
	NAM7163R	£64.00	RADIUS ARM, LH, reconditioned	1	(Refundable surcharge on this item - old unit required).
	21A1577Z	£78.65	HYDROLASTIC PIPE, suspension	2	universal replacement
	MTR4201	£37.10	GAUGE, camber measuring	1	
			(This gauge allows you to correctly set up your suspension to get the best from your Mini where it excels).		
	21A1517	NCA	BUMP STOP, cone type	2	original
	21A1520	£10.00	BUMP STOP, flat type	2	alternative

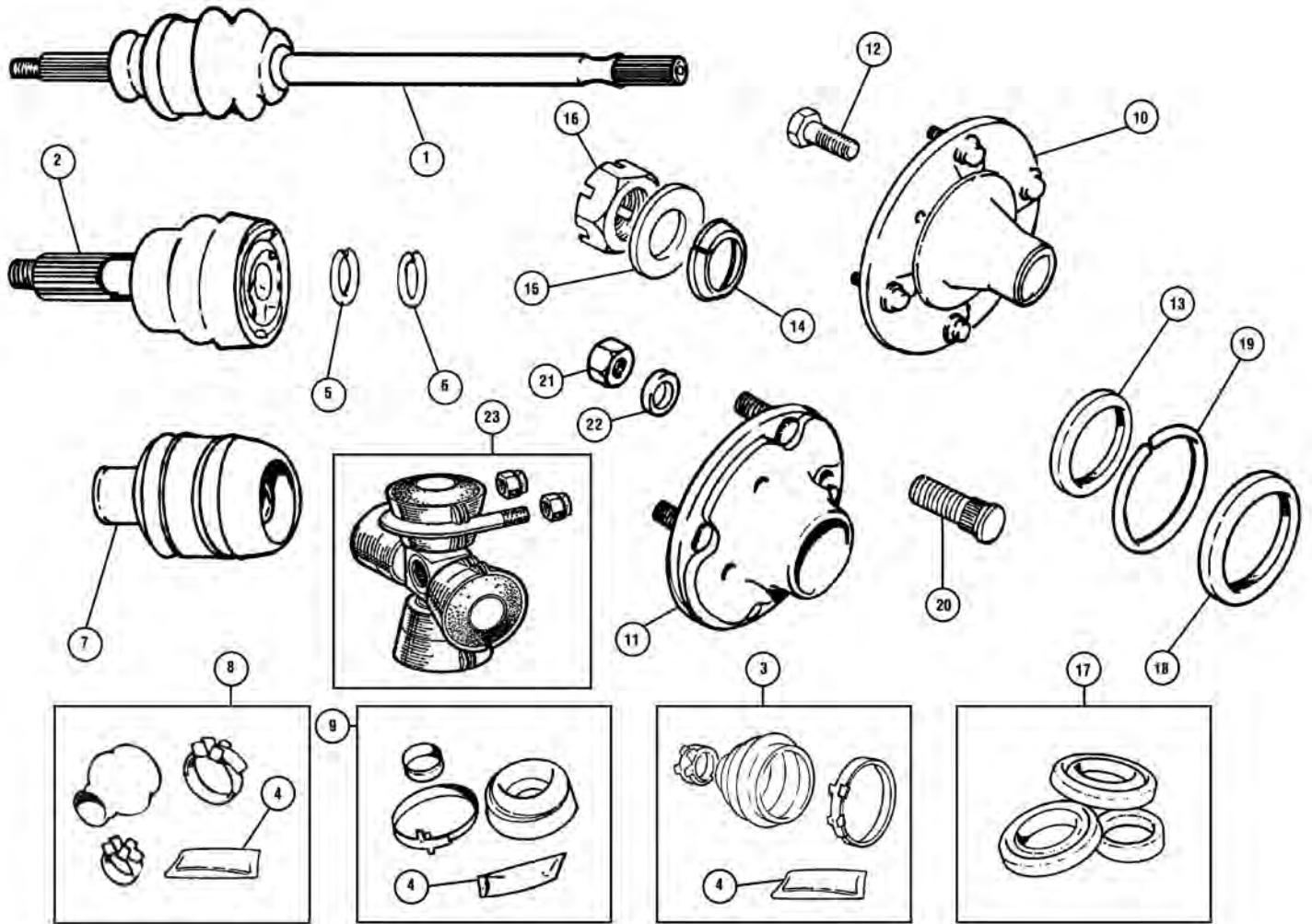

Part Number	Price £ea.	Description	Req.	Details
Drive Shafts and Flanges				
1	GCV1104 £127.30	DRIVE SHAFT RH, no inner joint	1	drum brakes
	GCV1103 £127.30	DRIVE SHAFT LH, no inner joint	1	To 1984
	GCV1100 NCA	DRIVE SHAFT RH, no inner joint	1	disc brakes
	GCV1101 NCA	DRIVE SHAFT LH, no inner joint	1	1984-On
2	GCV1105 £35.00	CV JOINT, outer	2	drum brake models
	GCV1013 £36.00	CV JOINT, outer	2	disc brake models
3	GSV1185 £13.60	GAITER KIT, heavy duty, OE	2	to fit GCV1105
	GDG233 NCA	GAITER KIT, standard duty, OE	2	
	GSV1053 £8.00	GAITER KIT, heavy duty, OE	2	to fit GCV1013
	GDG202 £7.70	GAITER KIT, standard duty, OE	2	
4	GDG999 £3.00	GREASE, separate sachet, 50cc	a/r	
5	37H8706 £2.05	CIRCLIP, inner CV thick section	2	
6	17H8597 NCA	CIRCLIP, outer CV tin section	2	
7	27H7880Z £140.00	HARDY SPICER JOINT, inner	2	auto and Cooper S
	GCV1102 £36.40	POT JOINT, inboard	2	
	GCD101 £30.36	COUPLING, drive shaft, rubber	2	early Mini
	QL5000 £67.00	COUPLING, nylon	1	upgrade to GCD101
	GUJ101 £8.60	COUPLING REPAIR KIT	2	auto and Cooper S
		(Repair kit for Hardy Spicer, (27H7880Z).		
8	GSV1192 £1.70	GAITER	2	sliding joint to drive shaft
	GSV1192Z NCA	GAITER KIT	2	sliding joint to drive shaft
	21A963 NCA	GAITER, OE	2	sliding joint to drive shaft
9	GSV1073 £10.20	GAITER KIT, heavy duty, OE	2	to fit GCV1102
	GSV1073 £10.20	GAITER KIT, standard duty, OE	2	
	DMR54680 NCA	INSTALL TOOL, CV boot	1	used to fit the CV gaiter
10	21A231 £36.40	DRIVE FLANGE	2	drum brakes
11	21A1270 £26.50	DRIVE FLANGE	2	7.5in disc brakes
	21A2695 £32.60	DRIVE FLANGE	2	8.4in disc brakes
	NAM6450F £42.00	DRIVE FLANGE	2	disc
			2	8.4in disc brakes
				vented

Part Number	Price £ea.	Description	Req.	Details
12	SF604061 £0.37	SCREW, drive flange to disc	8	7.5in disc brakes
	BTA370 £1.42	BOLT, drive flange to disc	8	Cooper S
			8	8.4in disc brakes
13	2A4295 £3.58	COLLAR, oil seal	2	disc
14	FAM9270 £8.50	COLLAR, outer, tapered	2	drum brakes
			2	disc brakes
Note: FAM9270 collar should be replaced whenever the hub nut BTA249 is removed! When re-installing the drive flange, collar and nut re-torque BTA249 without the collar but using a suitable sized flat washer then replace the flat washer with the tapered collar and re-torque.				
15	2A7323 £3.00	WASHER, outer, plain	2	drum brakes
16	BTA249 £4.94	NUT, hub 1 5/16" AF	2	disc brakes
	21A79 £2.57	NUT, hub 1 1/8" AF	2	drum brakes
17	GHK1140 £25.20	HUB BEARING KIT, includes seals	2	disc brakes
	GHK1018 £22.30	HUB BEARING KIT, includes seals	2	drum brakes
18	GHS101 £1.52	OIL SEAL, outer	2	
	GHS173 £2.00	OIL SEAL, inner with shield	2	
19	2A4361 NCA	SPACER, 0.094" seal to bearing	2	disc brakes
	21A1307 NCA	SPACER, 0.229" seal to bearing	2	drum brakes
20	NAM5645 £2.57	STUD, 1.1875", 30mm, shaft length	8	disc brakes
	21A2064 £1.36	STUD, 1.375", 35mm, shaft length	8	drum brakes
21	88G322 £0.79	WHEEL NUT, round chamfer	8	standard 10" road wheels
	113087 £1.32	WHEEL NUT, 600 chamfer angle	2	standard 12" road wheels
	FAM5701 £8.30	WHEEL NUT, round chamfer*	16	10" with hub caps
	FAM3428 NCA	WHEEL NUT, 600 chamfer*	16	12" with hub caps
	RRD10009 £3.74	WHEEL NUT	16	Cooper 1300cc
22	FAM2563 NCA	WASHER, for wheel nut*	16	

*Note: If your car is fitted with wheel trims retained by the wheel nut, then you will require the wheel nuts marked with an asterisk. Care must be taken when ordering as 'radius' and 'chamfered' wheel nuts are not interchangeable!

23	GCD101 £30.36	DRIVE COUPLING, rubber	2	sold individually
	QL5000 £67.00	DRIVE COUPLING KIT (nylon & roller bearing).	1	sold as a pair

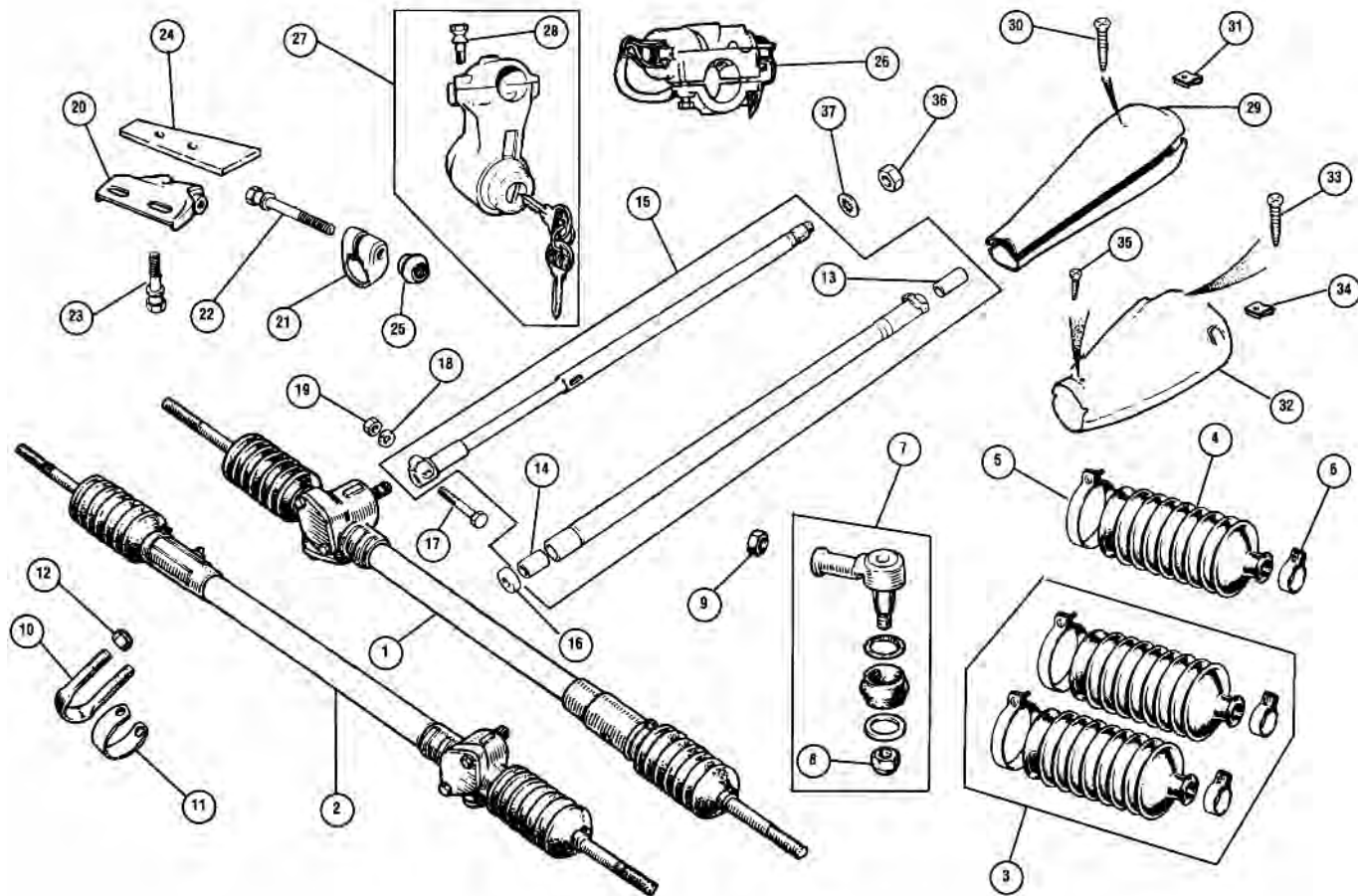

iii. Part Number Price £ea. Description Req. Details

Steering Rack

RHD Steering Rack

1	GSR371	£126.70	STEERING RACK	1	new
	CAJJ1570	£116.00	STEERING RACK, quick rack	1	2.2 turns lock to lock

LHD Steering Rack

2	GSR1163	£126.70	STEERING RACK	1	new
	CAJJ1571	£119.00	STEERING RACK, quick rack	1	2.2 turns lock to lock

Gaiters All Models

3	GSV1153	£6.00	GAITER KIT, for OE racks	1	2 boots and 4 metal clips
	GSV1153	£6.00	GAITER KIT	1	2 boots and plastic ties
	GRG205	NCA	GAITER KIT, for OE racks	1	2 boots and 4 plastic ties
	GRG210Z	£10.90	GAITER KIT, aftermarket racks	1	2 boots and 4 plastic ties
4	17H6298	£3.07	GAITER, OE racks only	2	single, no clips
5	ADG1682	£2.08	CLIP, large	2	gaiter to rack casing
6	GGT1117X	£1.50	CLIP, small	2	gaiter to track rod
7	GSJ734	£15.00	TRACK ROD END	2	
	GSJ734Z	£5.40	TRACK ROD END	2	
	GSJ158	£7.30	TRACK ROD END	2	slightly longer in thread
	GSJ158Z	£6.00	TRACK ROD END, reproduction	2	
8	GHF223	£0.48	NUT, nyloc, imperial	2	track rod end
	NY210041	£1.36	NUT, nyloc, metric	2	to steering arm.

Note: Due to Rover changing sources on the track rod ends, the pin thread can vary. Please check before ordering, nuts with imperial threads use a 9/16" AF spanner.

9	FNZ208	£0.62	LOCK NUT, track rod end to track rod	2	
10	2A6208	£7.90	U BOLT, rack mounting to body	2	
11	21A2553	£1.20	PACKING PIECE, nylon strip	2	
12	GHF222	£0.62	NUT, nyloc	4	

iii. Part Number Price £ea. Description Req. Details

Steering Column

Note: See Accessories section for our full range of steering wheels.

21A2252	NCA		HORN PUSH, centre	1	Mini motif MkII and MkIII
13	GSV1095	£2.90	BUSH, column top	1	
14	GSV1127	£6.02	BUSH, column lower, felt	1	To VIN 380107
	NAM8563	£5.00	BUSH, column lower	1	From VIN380108 On
	NAM8563SP	£7.80	BUSH, column lower, polyurethane	1	alternative
15	NAM8527	£338.00	COLUMN	1	fits all models To 1996
	QMB101550PMA	£402.00	COLUMN ASSEMBLY	1	mpi 1996-On
16	21A30	£1.45	SEAL, rack to body	1	
17	BH604111	£0.68	BOLT, pinching clamp	1	
18	GHF331	£0.17	WASHER, spring	1	
19	GHF200	£0.19	NUT	1	
20	21A2463	NCA	BRACKET, clamp to body	1	
	GAC8426X	£3.60	DROP BRACKET, steering column	1	
21	21A2666	£4.85	CLAMP, column to bracket	1	
22	51K4006	£5.00	SHEARBOLT, column clamp	1	2.69" long
23	51K4002	£4.80	SHEARBOLT, bracket to body	2	1.45" long
24	21A2464	£9.90	NUT PLATE, bracket to body	1	
25	21H295	£3.32	NUT, column clamp	1	
26	18G8892	NCA	LOCK, steering, key in side	1	To 1976
27	BHM7107	£43.00	LOCK, steering, key facing driver	1	1976-On
	BHM7252	NCA	LOCK, steering, key facing driver	1	Mini 25
	QRF100750	£64.20	LOCK, steering, key in side	1	mpi 1996-On
28	51K4001	£2.26	SHEARBOLT, steering lock	2	
29	18G8803	NCA	COWLING	1	
			(With steering lock, single stalk).		
30	13H3737	NCA	SCREW, cowl to column	4	To 1976
31	GHF711	£0.25	SPIRE CLIP, on column	4	
32	BHM7085	£50.00	COWLING, twin stalks, black	1	
33	AD606083	£1.20	SCREW, cowl to column	3	1976-On
34	GHF711	£0.25	CLIP, on column	2	
35	AC606051	£0.32	SCREW, cowling, (twin stalks)	1	
36	ACH6001	£5.12	NUT, steering wheel retaining	1	1 5/16" AF
	QYH10007	£11.10	NUT, steering wheel retaining	1	1" AF
37	6K900	£1.00	WASHER, shakeproof	1	use with ACH6001
	QYF10005	NCA	WASHER, shakeproof	1	use with QYH10007

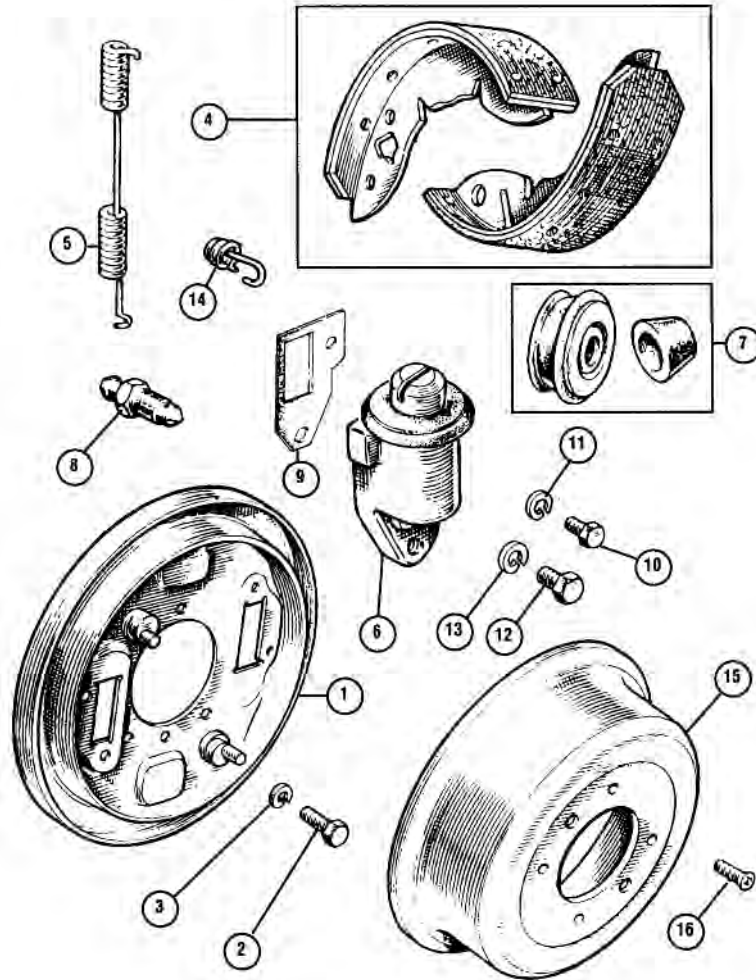

ill. Part Number Price £ea. Description Req. Details

Front Brakes

Drum Brake Twin Leading Shoe (10" Wheels)

1	37H2013	£38.50	BACK PLATE, RH	1	
	37H2014	£38.50	BACK PLATE, LH	1	
2	SH605051	£0.32	BOLT, backplate to hub	6	
3	GHF332	£0.28	WASHER, locking	6	
4	GBS733AF	£13.00	BRAKE SHOES, set of four	1	asbestos free
5	AAU8243	£1.80	SPRING, brake shoe return	4	
6	GWC102	NCA	WHEEL CYL. RH, 0.8125 bore size	2	Mkl only, early back plate
	GWC102Z	£12.40	WHEEL CYL. RH, 0.8125 bore size	2	Mkl only, early back plate
	GWC103Z	£14.00	WHEEL CYL. LH, 0.8125 bore size	2	Mkl only, early back plate
	GWC126	£12.70	WHEEL CYL. RH, 0.9375 bore size	2	
	GWC126Z	£7.80	WHEEL CYL. RH, 0.9375 bore size	2	

ill. Part Number Price £ea. Description Req. Details

GWC127	£12.70	WHEEL CYL. LH, 0.9375 bore size	2
GWC127Z	£7.80	WHEEL CYL. LH, 0.9375 bore size	2

Note: When replacing the wheel cylinders you will probably need to replace the bolts (items 10 and 12).

7	GRK2002	£3.84	REPAIR KIT, wheel cylinder	4
	GRK2002Z	£3.84	REPAIR KIT, wheel cylinder	4
8	3H2428	£0.95	BLEED NIPPLE	4
9	37H3833	£0.73	GASKET, w/cylinder to back plate	4
10	7H7520	£2.95	BOLT, w/cyl to back plate, (small)	4
11	GHF331	£0.17	WASHER, spring	4
12	SH605051	£0.32	BOLT, w/cyl to back plate, (large)	4
13	GHF332	£0.28	WASHER, spring	4
14	27H3753	£5.30	SPRING, retaining, shoe to cylinder	4
15	GDB105Z	£12.00	BRAKE DRUM	2
16	CMZ407	£0.73	SCREW, brake drum retaining	4

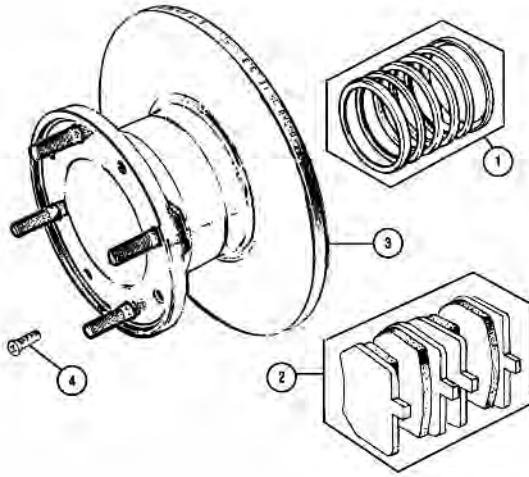

iii. Part Number Price £ea. Description Req. Details

Brakes

Front Disc Brakes 7.0" (10" wheels)

Note: Calipers for 7.0" disc brake model's are not available.

Part Number	Price £ea.	Description	Req.	Details
1 GRK5009Z	£3.68	SEAL KIT, per caliper	2	
2 GBP102KV	£17.10	PAD SET, EBC Ultimix	1	road
GBP102G	£32.00	PAD SET, EBC Greenstuff	1	road/fast road
GBP102Y	£57.00	PAD SET, EBC Yellowstuff	1	fast road/track
3 BTA193	£60.00	DISC	2	
4 CMZ407	£0.73	SCREW, disc to drive flange	8	

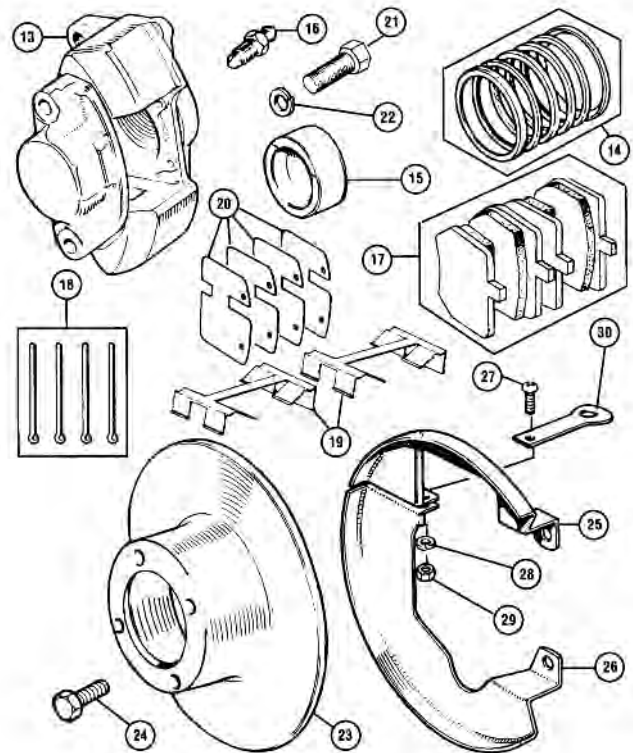

iii. Part Number Price £ea. Description Req. Details

Front Disc Brakes 1984-On (12" Wheels)

Part Number	Price £ea.	Description	Req.	Details
13 GBC141E	£69.00	CALIPER, RH, exchange	1	
GBC138E	£69.00	CALIPER, LH, exchange	1	
14 GRK5008	£7.80	SEAL KIT, per caliper	2	
15 17H7960	£10.00	PISTON, caliper	4	
16 3H2428	£0.95	BLEED NIPPLE	2	
17 GBP281	£12.90	PAD SET	1	
GBP281CM	£23.95	PAD SET, EBC Ultimix	1	road
STR505G	£37.30	PAD SET, EBC Greenstuff	1	road/fast road
STR505Y	£80.70	PAD SET, EBC Yellowstuff	1	fast road/track
STR5051	£58.80	PAD SET, Mintex M1144	1	fast road/track
18 GBK1010	£0.84	SPLIT PIN, car set	1	
19 17H7963	£1.32	SPRING CLIP, anti rattle	2	
17H7963X	£1.96	SPRING CLIP, anti rattle	2	
20 17H2460	£1.45	SHIM, anti squeal	4	
21 53K1048	£0.94	BOLT, caliper to hub	4	
22 GHF333	£0.28	WASHER, spring	4	
23 GBD90806	£11.40	DISC	2	
GBD90806Z	NCA	DISC, aftermarket	2	
24 BTA370	£1.42	BOLT, disc to drive flange	8	
25 21A2613	£21.60	BACK PLATE, RH top	1	
21A2613Z	£14.00	BACK PLATE, RH top, aftermarket	1	
21A2617	£20.00	BACK PLATE, LH top	1	
21A2617Z	£14.00	BACK PLATE, LH top, aftermarket	1	
26 21A2614	£24.00	BACK PLATE, RH lower	1	
21A2614Z	£14.00	BACK PLATE, RH lower, aftermarket	1	
21A2618	NCA	BACK PLATE, LH lower	1	
21A2618Z	£14.00	BACK PLATE, LH lower, aftermarket	1	
27 PMZ308	£0.28	SCREW, backplate	4	
28 WL700101	£0.19	WASHER, locking	4	
29 GHF206	£0.13	NUT	4	
30 BTA1208	£4.10	BRACKET, back plate RH	1	
BTA1209	£4.10	BRACKET, back plate LH	1	
17H7679	£1.25	SEAL, caliper bridge	2	seal not shown

Warning: Do not split the caliper into two halves unless absolutely necessary.

Front Disc Brake Parts - 4 Pots

GBD496	£19.50	BRAKE DISC, vented, each	2	
MS0508	NCA	BRAKE DISCS, vented, 7.9", (pair)	1	fit 10" wheel only
KADDISC12	NCA	BRAKE DISCS, vented, (pair)	1	fit 12" wheel only
		(To fit 12" wheels with Metro or KAD type vented calipers).		
MT1203	£35.00	BRAKE DISCS, vented, (pair)	1	fit 12" wheel only
		(To fit 12" wheels with Metro or KAD type vented calipers).		
GBP258	£15.80	PAD SET, standard	1	
GBP258KV	£28.80	PAD SET, EBC Ultimix	1	road
GBP258G	£45.00	PAD SET, EBC Greenstuff	1	road/fast road
GBP258Y	£71.60	PAD SET, EBC Yellowstuff	1	fast road/track
TMG309474	NCA	PAD SET, Mintex M1144	1	fast road/track
GRK5003	£10.30	SEAL KIT, brake caliper, '4 pots'	2	Metro/4 pot calipers
MT5402	£12.20	PISTON, caliper, stainless steel	8	Metro/4 pot calipers

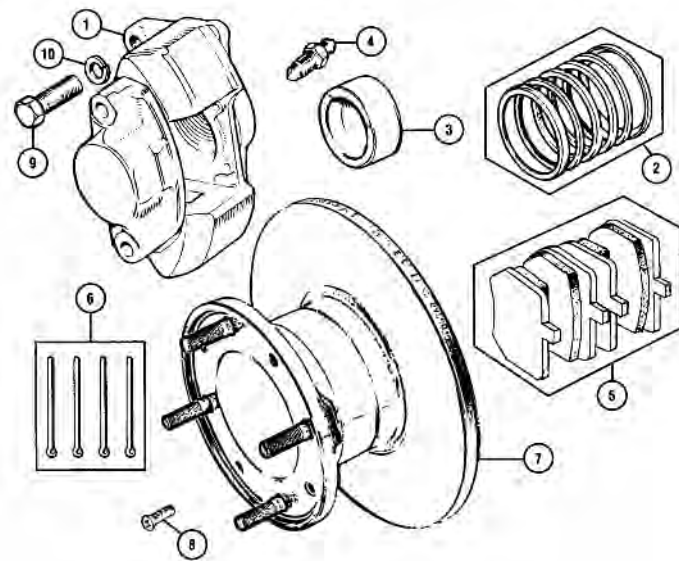

iii. Part Number Price £ea. Description Req. Details

Front Disc Brakes 7.5" (10" Wheels)

Part Number	Price £ea.	Description	Req.	Details
1 27H4656	£46.00	CALIPER, RH, original	1	1275GT & Cooper S
27H4657	£46.00	CALIPER, LH, original	1	
27H4656Z	£88.00	CALIPER, RH, aftermarket	1	
27H4657Z	£88.00	CALIPER, LH, aftermarket	1	
2 GRK5006	£6.00	SEAL KIT, per caliper	2	
GRK5006Z	£5.00	SEAL KIT, per caliper, aftermarket	2	
3 17H8626SS	£9.00	PISTON, caliper, stainless steel	4	
4 3H2428	£0.95	BLEED NIPPLE	2	
5 GBP103AF	£17.80	BRAKE PAD SET, front, standard	1	
GBP103KV	£17.60	BRAKE PAD SET, front, EBC Ultimix	1	road
GBP103G	£38.30	BRAKE PAD SET, front, EBC Greenstuff	1	road/fast road
GBP103Y	£59.00	BRAKE PAD SET, front, EBC Yellowstuff	1	fast road/track
6 TMG307521	£1.96	SPLIT PIN	4	
7 GBD101	£28.00	BRAKE DISC, 7.5" diameter	2	
8 SF604061	£0.37	SCREW, disc to drive flange	8	
9 53K1048	£0.94	BOLT, caliper to hub	4	
10 GHF333	£0.28	WASHER, locking	4	

Warning: Do not split the caliper into two halves unless absolutely necessary.

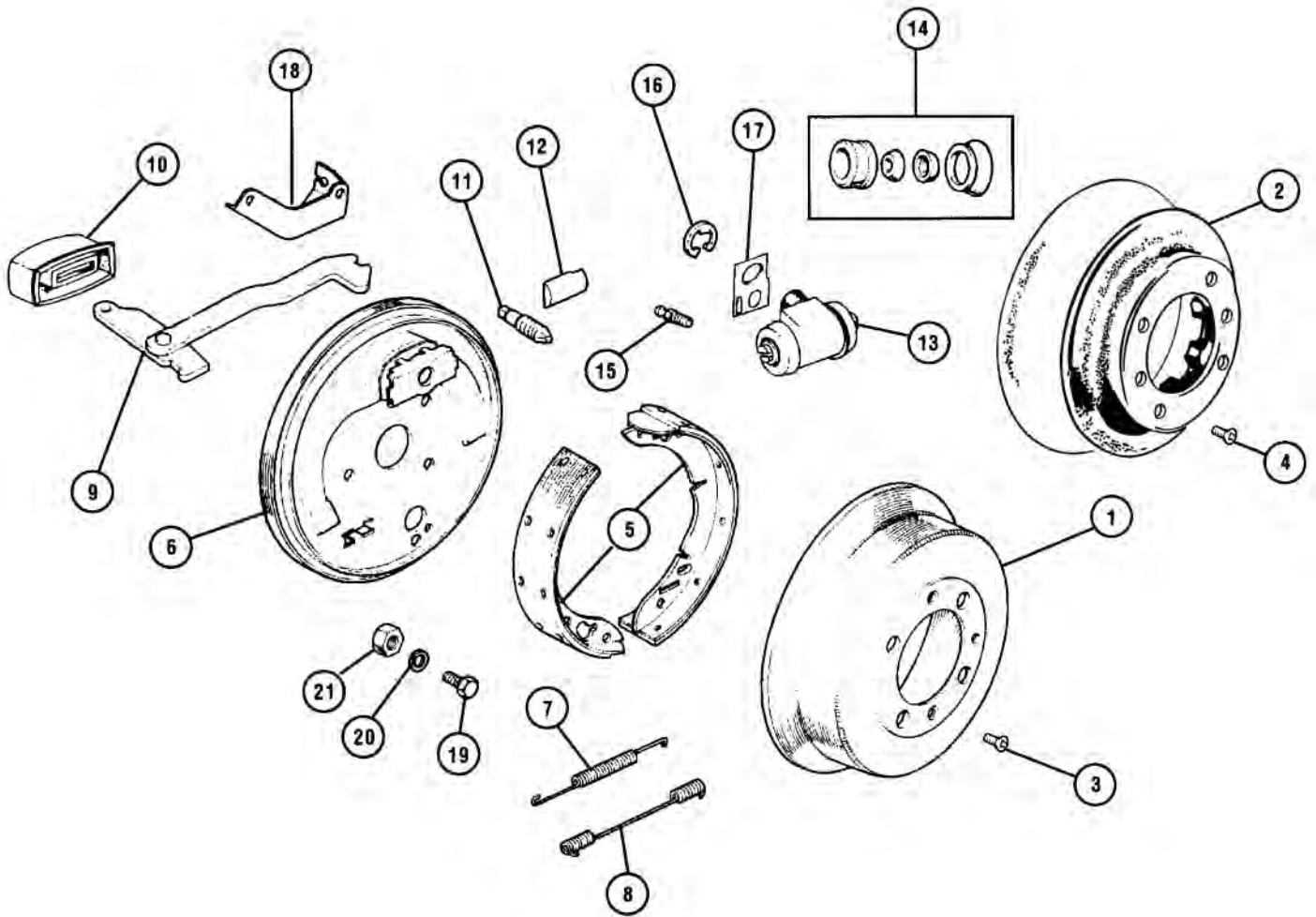

iii.	Part Number	Price £ea.	Description	Req.	Details
Rear Brakes					
1	GDB105Z	£12.00	BRAKE DRUM	2	10" wheels } To 1984
2	GDB106Z	£17.00	BRAKE DRUM, with spacer	2	12" wheels } 1984-On
	MT1210	£80.00	BRAKE DRUM, with spacer	1	alloy superfins
3	CMZ407	£0.73	SCREW, brake drum	4	To fit GDB105Z
4	SF604121	£0.70	SCREW, brake drum	4	To fit GDB106Z
5	GBS834AF	£13.70	BRAKE SHOES, car set of 4 shoes	1	
6	21A1058	£37.75	BACK PLATE, RH	1	
	21A1060	£37.75	BACK PLATE, LH	1	
Note: Only one type of back plate is now available. When replacing a back plate, you may need to drill a new hole for the wheel cylinder locating roll pin.					
7	17H7621	£2.53	SPRING, lower shoe return	2	
8	17H8092	£2.42	SPRING, upper shoe return	2	
9	SMN10005	£26.00	LEVERS, handbrake operating, (pair)	1	set of 2
10	17H8057	£2.38	DUST SEAL, lever aperture	2	
11	17H7619	£5.05	ADJUSTER WEDGE	2	
12	17H7618	£4.90	ADJUSTER TAPPETS	4	
	17H7620	£8.30	ADJUSTER KIT, per side	2	includes tappets } and adjusters
13	GWC1126	£18.74	WHEEL CYLINDER, OE diagonal sys.	2	not UK 1976-77

iii.	Part Number	Price £ea.	Description	Req.	Details
	GWC1126Z	£9.70	WHEEL CYLINDER, diagonal system	2	not UK 1976-77
	GWC1131	£14.00	WHEEL CYLINDER, OE diagonal sys.	2	not UK 1976-77
	GWC1131Z	£12.20	WHEEL CYLINDER, diagonal system	2	not UK 1976-77
	GWC1101	£14.40	WHEEL CYLINDER, OE	2	To 1967
	GWC1101Z	£10.80	WHEEL CYLINDER	2	To 1967
	GWC1102	£9.56	WHEEL CYLINDER, OE	2	1967-On
	GWC1102Z	£7.00	WHEEL CYLINDER	2	1967-On
	GWC1134	NCA	WHEEL CYLINDER, OE (Japan/Norway).	2	no locating pin
14	BHM7015	NCA	REPAIR KIT, wheel cylinder	2	To fit GWC1126
	GRK2003	NCA	REPAIR KIT, wheel cylinder	2	To fit GWC1131
	GRK2014	£6.00	REPAIR KIT, wheel cylinder	2	To fit GWC1102
	GRK2014Z	£6.20	REPAIR KIT, wheel cylinder, aftermarket	2	To fit GWC1102
	8G8801Z	£8.70	REPAIR KIT, wheel cylinder	2	To fit GWC1101
	18G9071Z	£3.18	REPAIR KIT, wheel cylinder	2	to fit GWC1134
15	513118A	£1.60	BLEED NIPPLE	2	All except GWC1131
	3H2428	£0.95	BLEED NIPPLE	2	to fit GWC1131 only
16	17H7949	£0.65	CIRCLIP, w/cylinder retaining	2	
17	37H4642	£1.00	GASKET, w/cylinder to back plate	2	
18	21A1669	£14.90	BRACKET, RH, handbrake cable	1	
	21A1670	£14.90	BRACKET, LH, handbrake cable	1	
19	GHF103	£0.54	SCREW, back plate to radius arm	6	
20	GHF332	£0.28	WASHER, locking	6	
21	GHF201	£0.12	NUT	6	

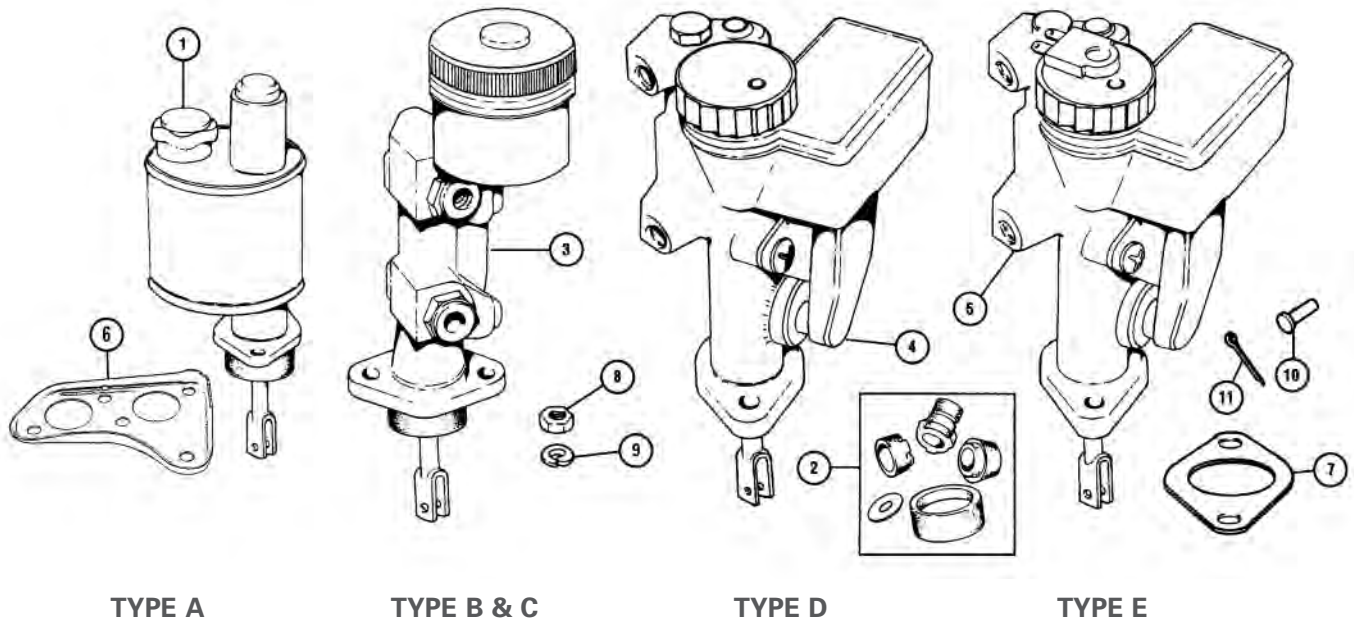

ill.	Part Number	Price £ea.	Description	Req.	Details
------	-------------	------------	-------------	------	---------

Brake Master Cylinders

Type A: Single Line System

1	GMC153	NCA	MASTER CYLINDER, brake, 0.75" bore (Aftermarket with plastic reservoir).	1	drum brakes 1959-62; Coopers with servo 1961-62
	GMC171	£81.30	MASTER CYLINDER, brake, 0.7" bore (Original type with round metal 60mm high reservoir. Use DOT4/5 fluid only).	1	drum brakes 1962-75; replacement for original GMC105
	GMC171Z	£51.20	MASTER CYLINDER, brake, 0.7" bore (Aftermarket with plastic reservoir).	1	Coopers without servo
	GMC172	£80.40	MASTER CYLINDER, brake, 0.7" bore (Original type with round metal 75mm high reservoir. Use DOT4/5 fluid only).	1	disc brake Coopers & 1275GT 1963-75
2	GRK1026	£8.00	REPAIR KIT, 0.75" bore master cyl. (With one end cap seal one ring seal on piston).	1	GMC153 type

Note: Before ordering a seal kit for a 0.7" master cylinder, please check which type of piston seals are used in your master cylinder. The master cylinder manufacturer changed the specification of the piston seals; early pistons used one cap seal (located on the end of the piston) & one ring seal. Later master cylinders have two ring seals.

	GRK1028	£11.00	REPAIR KIT, 0.7" bore master cyl. (With one end cap seal one ring seal on piston).	1	for 0.7" bore cylinders GMC171 and GMC172 type
	GRK1028Z	£6.00	REPAIR KIT, 0.7" bore master cyl. (Aftermarket, with one end cap seal one ring seal on piston).	1	
	GRK1006Z	£3.58	REPAIR KIT, 0.7" bore master cyl. (with two ring seals).	1	
	513123A	£4.00	CAP	1	all cylinders

Type B: Front To Rear Split System

3	GMC159	NCA	BRAKE MASTER CYLINDER	1	round plastic reservoir
2	GRK1019	NCA	REPAIR KIT	1	
	GRK1019Z	£29.40	REPAIR KIT	1	
	AAU3815	£10.90	CAP	1	

Type C: Diagonal Split System

3	GMC160	NCA	BRAKE MASTER CYLINDER	1	round plastic reservoir
2	GRK1019	NCA	REPAIR KIT	1	

ill.	Part Number	Price £ea.	Description	Req.	Details
------	-------------	------------	-------------	------	---------

	GRK1019Z	£29.40	REPAIR KIT	1	
	AAU3815	£10.90	CAP	1	

Type D: Diagonal Split System

4	GMC167	NCA	BRAKE MASTER CYLINDER	1	square plastic reservoir
2	GRK1002	£36.00	REPAIR KIT	1	
	GRK1002Z	£9.25	REPAIR KIT, aftermarket	1	
	GRK907014	NCA	CAP	1	

Type E: Front To Rear Split System

5	GMC227	£106.60	BRAKE MASTER CYLINDER	1	square plastic reservoir
2	GRK1035	£30.00	REPAIR KIT	1	
	AEU1796	NCA	CAP, with failure switch	1	

Note: Between 1980 and 1985 the Mini had 4 different types of master cylinder fitted, these being part numbered GMC173 and GMC198 having a pressure failure switch fitted to the body of the cylinder and GMC192 and GMC195 with a fluid level switch fitted to the cap, all these cylinders are superseded by GMC227.

As the cylinder is manufactured with metric fittings the conversion pipes must be used in conjunction with GMC227 when replacing an original master cylinder. Although it is possible to rebuild the original master cylinder with a repair kit.

	BAU5654	£33.30	PIPE CONVERSION KIT	1	RHD
	BAU5655	£24.65	PIPE CONVERSION KIT	1	LHD

All Models

6	14A6733	£13.00	BRACKET, engine stabiliser	1	fitted under brake and clutch master cylinders
7	31G279	£1.96	GASKET, single line master cylinder	1	
	31G840	£2.05	GASKET, dual master cylinder	1	
	8 FNZ505	£0.68	NUT, master cylinder to bracket	2	
	9 GHF332	£0.28	WASHER, locking	2	
	10 CLZ512	£1.52	CLEVIS PIN, pedal to push rod	1	
	11 GHF502	£0.19	SPLIT PIN	1	

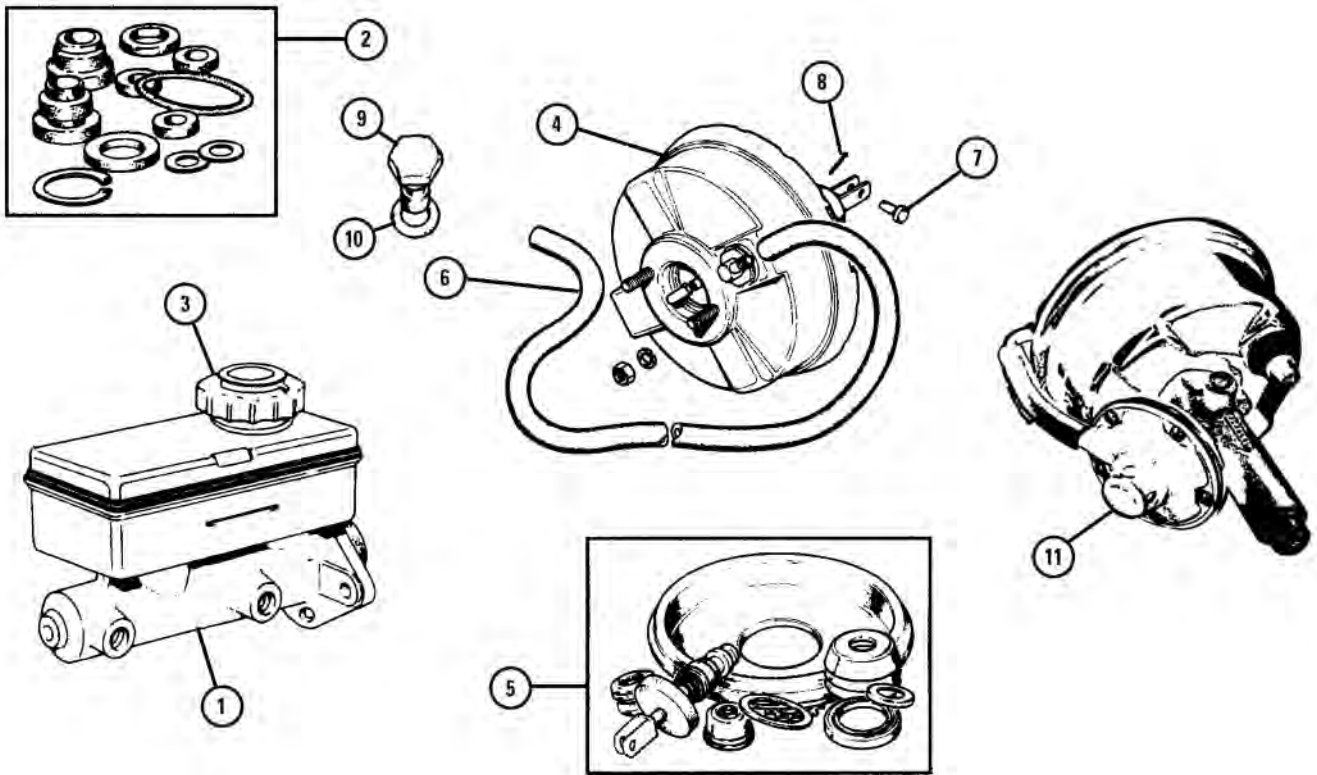

ill.	Part Number	Price £ea.	Description	Req.	Details
Front To Rear Split System With Direct Acting Servo					
1	GMC90376	£111.20	BRAKE MASTER CYLINDER*	1	metric fittings 1989-On

*Note: The early direct acting brake master cylinder is no longer available, it has been superseded by the later version GMC90736, which has metric threads. Please check your pipe work carefully before fitting. A rebuild kit is available for GMC242, see GRK1032 below.

2	GRK1032	£18.00	REPAIR KIT	1	
	GRK1032Z	£14.00	REPAIR KIT, aftermarket	1	
3	GRK6009	£14.00	CAP, with float switch	1	
4	GSM119	£127.90	SERVO UNIT (Direct-acting attached to master cylinder).	1	1989-On
5	GSM120	NCA	REPAIR KIT	1	
6	NAM8568	NCA	VACUUM HOSE, with return valve	1	
7	NAM8540	NCA	CLEVIS PIN, bell crank	2	

ill.	Part Number	Price £ea.	Description	Req.	Details
8	511032	£0.94	SPLIT PIN	1	
9	2A715	£21.10	BANJO BOLT, brake servo	1	
	ADP210	£6.24	PLUG, manifold blanking	1	if servo take-off not required
10	AED172	£1.15	WASHER	a/r	use 2 washers with banjo bolt

Remote Servo Kit

Note: This servo kit fits all single line brake systems.

11	TT3949	£198.00	SERVO KIT, remote	1	lockheed
	TT3949Z	£95.50	SERVO KIT, remote	1	aftermarket
	18G8938	£57.60	REPAIR KIT, servo	1	for TT3949

Note: As MkIII S TT3949 can be used as conversion on Minis, comes as complete kit. Fitting a remote servo means less effort required when braking.

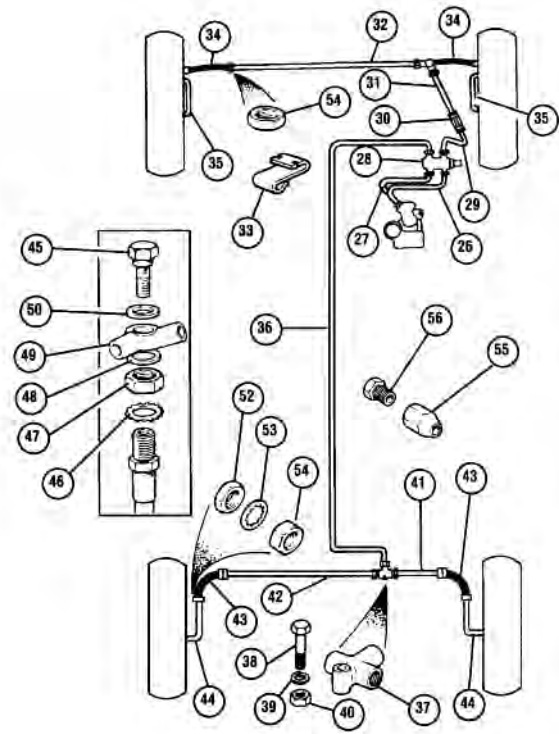
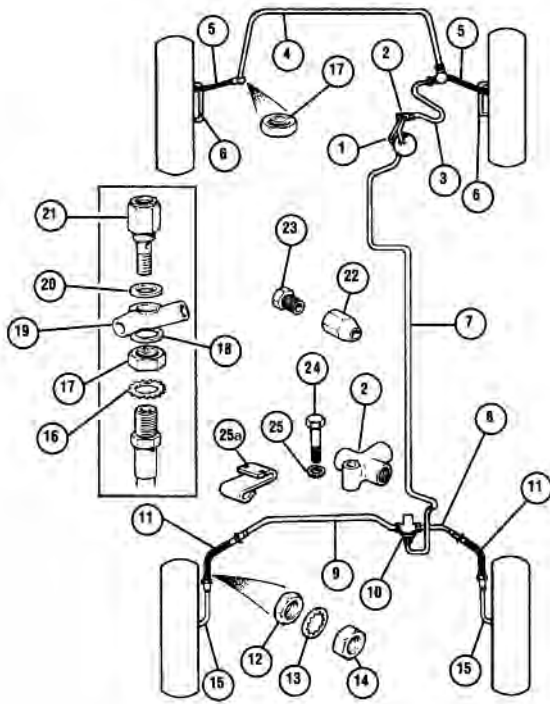

ill. Part Number Price £ea. Description Req. Details

Brake Pipes

Brake Pipes For Single Line Brakes (Drum Brakes)

1	GPP14AA	£11.75	BRAKE PIPE	1	master cylinder to 3 way union
2	3H2424	£7.80	CONNECTOR, 3 way	1	
3	GPP18AA	£12.20	BRAKE PIPE, 3 way	1	union to banjo connector
4	GPP46AA	£13.66	BRAKE PIPE	1	banjo connects to LH front hose
5	GBH170	£6.50	BRAKE HOSE, front, flexible	2	
	GBH170Z	£5.40	BRAKE HOSE, front, flexible	2	aftermarket
	GAC8412X	NCA	BRAKE HOSES, 4, stainless steel	1	front and rear
	MT5105	NCA	BRAKE HOSES, 5, stainless steel (Includes GAC8447X clutch hose).	1	front and rear
	MT5401	NCA	BRAKE HOSES, 5, stainless steel (Includes GAC0080 clutch hose).	1	front and rear
	233220A	£0.84	WASHER, copper, brake to cylinder	2	
6	GPP10AA	£11.75	BRAKE PIPE, front hub bridge pipe	2	
7	GPP102AA	£19.00	BRAKE PIPE	1	3 way union to regulator valve
8	GPP6AC	£9.05	BRAKE PIPE	1	regulator valve to RH rear hose
9	GPP26AC	£12.00	BRAKE PIPE	1	regulator valve to LH rear hose
10	21A2031	NCA	REGULATOR VALVE	1	mounted on rear subframe
11	GBH250	£4.96	BRAKE HOSE, rear, flexible	2	
	GBH250Z	£3.60	BRAKE HOSE, rear, flexible	2	aftermarket
	MT5101	£24.80	BRAKE HOSES, rear, stainless steel	1	pair
	MT5104	NCA	BRAKE HOSES, rear, stainless steel (From subframe to wheel cylinder).	1	pair
12	NT606041	£0.54	NUT, locking, hose to radius arm	2	
13	GHF323	£0.19	WASHER, locking	2	
14	GHF202	£0.19	NUT	2	
15	GPP10AC	£11.75	BRAKE PIPE	2	rear brake hose to wheel cylinder
16	WE600101	£0.42	WASHER, locking	2	
17	21A228	£3.32	NUT, locking to subframe RH/LH	1	
	2K8686	£1.20	NUT, locking to subframe RH/LH	1	
18	3H550	£0.60	WASHER, copper	1	
19	11D5263	£27.70	UNION, 2 way banjo	1	
20	233220A	£0.84	WASHER, copper	3	
21	7H7995	£12.60	BOLT, banjo for brake light switch	1	
22	AEHU1A	£1.90	UNION, female UNF thread	a/r	
23	TM606031	£0.94	UNION, male UNF thread	a/r	
24	GHF101	£0.28	BOLT, 3 way connector to bulkhead	1	
25	GHF331	£0.17	WASHER	1	
25a	11K9181	£0.60	CLIP, pipe to subframe	a/r	

ill. Part Number Price £ea. Description Req. Details

Brake Pipes For Split System (Front To Rear)

Note: P.D.W.A. = (Pressure Differential Warning Actuator).

26	GPP13DD	£11.26	PIPE, m/cyl. to P.D.W.A., (tandem)*	1	long, RHD
	GPP30DD	£13.15	PIPE, m/cyl. to P.D.W.A.	1	long, LHD
27	GPP10DD	£11.75	PIPE, m/cyl. to P.D.W.A., (tandem)*	1	short, RHD
	GPP29DD	£13.15	PIPE, master cylinder to P.D.W.A.	1	short, LHD
28	13H5905	NCA	FAILURE SWITCH, 4 way, P.D.W.A.	1	To 1975, LHD
	FAM7821	£98.00	P.D.W.A.	1	All RHD and LHD 1975-On
29	GPP9DD	£10.00	BRAKE PIPE, P.D.W.A. to connector*	1	*in-line connectors
30	BMK2466A	£14.60	CONNECTOR, in-line	1	
31	GPP10AD	£11.75	BRAKE PIPE, connector to banjo	1	
32	GPP44AA	£13.66	BRAKE PIPE, banjo to LH front hose	1	
33	11K9181	£0.60	CLIP, pipe to subframe	2	
34	GBH170	£6.50	BRAKE HOSE, front	2	drum
	GBH170Z	£5.40	BRAKE HOSE, front	2	disc
	GBH249	£5.90	BRAKE HOSE, front	2	aftermarket
	GBH246	NCA	BRAKE HOSE, front, flexible	4	ERA turbo twin feed
	GBH246Z	£10.30	BRAKE HOSE, front, flexible	4	ERA turbo non genuine
	GAC8412X	NCA	BRAKE HOSES, 4, stainless steel	1	front and rear
	MT5102	NCA	BRAKE HOSES, 2, stainless steel	1	front, (pair)
	MT5105	NCA	BRAKE HOSES, 5, stainless steel (Including GAC8447X clutch hose).	1	front and rear
	MT5401	NCA	BRAKE HOSES, 5, stainless steel (Including GAC0080 clutch hose).	1	front and rear
	233220A	£0.84	WASHER, copper	2	brake hose to cylinder
35	GPP10AA	£11.75	BRAKE PIPE, front bridge pipe	2	
36	GPP97AD	£18.40	BRAKE PIPE	1	P.D.W.A. to rear T piece
37	3H2424	£7.80	T PIECE	1	
38	SH604091	£0.79	SCREW, T piece to rear subframe	1	
38	GHF331	£0.17	WASHER, locking	1	
40	GHF200	£0.19	NUT	1	
41	GPP6AC	£9.05	BRAKE PIPE	1	T piece to RH rear hose
42	GPP26AC	£12.00	BRAKE PIPE	1	T piece to LH rear hose
43	GBH250	£4.96	BRAKE HOSE, rear, flexible	2	
	GBH250Z	£3.60	BRAKE HOSE, rear, flexible	2	aftermarket
	MT5101	£24.80	BRAKE HOSES, rear, stainless steel	1	pair
	MT5104	NCA	BRAKE HOSES, rear, stainless steel	1	pair, subframe to wheel cylinder
44	GPP10AC	£11.75	BRAKE PIPE, rear hose to w/cylinder	2	
45	C5192A	£5.40	BOLT, banjo	1	
46	WE600101	£0.42	WASHER, locking	2	
47	21A228	£3.32	NUT, locking to subframe	1	RH
	2K8686	£1.20	NUT, locking to subframe	1	RH/LH
48	3H550	£0.60	WASHER, copper	1	
49	11D5263	£27.70	UNION, 2 way banjo	1	
50	233220A	£0.84	WASHER, copper	3	

ill. Part Number Price £ea. Description Req. Details

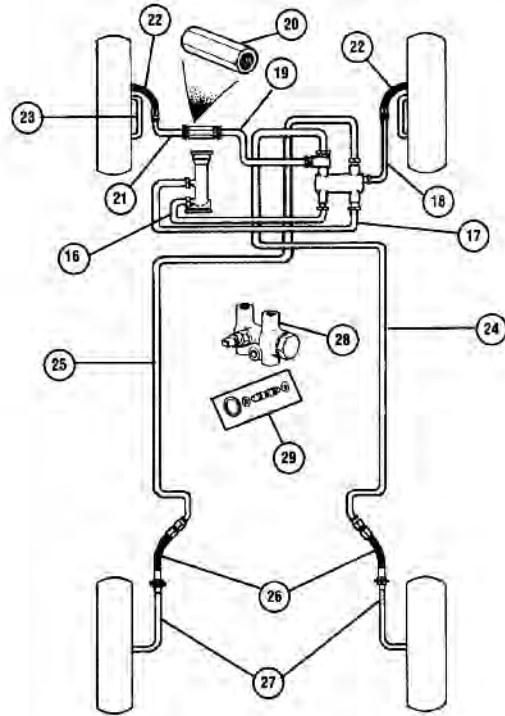
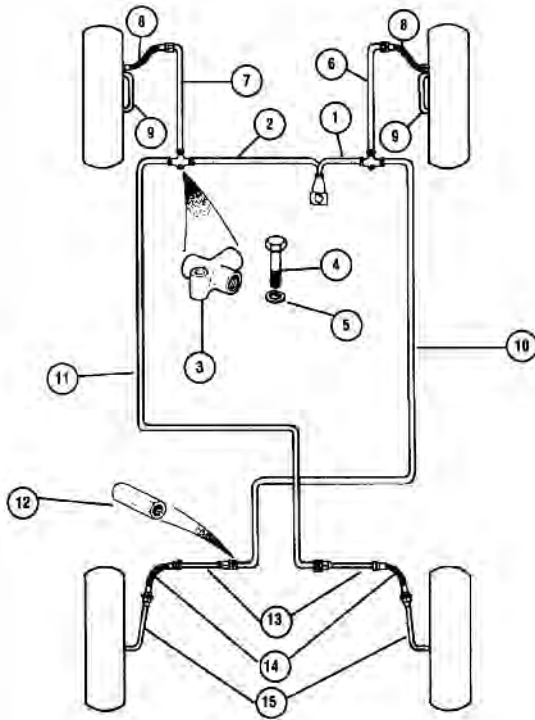

ill.	Part Number	Price £ea.	Description	Req.	Details
52	NT606041	£0.54	NUT, locking, hose to radius arm	2	
53	GHF323	£0.19	WASHER, locking	2	
54	GHF202	£0.19	NUT	2	
55	AEHU1A	£1.90	UNION, female UNF thread	a/r	
56	TM606031	£0.94	UNION, male UNF thread	a/r	

Brake Pipes for Diagonal Split System (RHD)

1	GPP10AD	£11.75	BRAKE PIPE	1	master cylinder to RH 3 way union
2	GPP34AD	NCA	BRAKE PIPE	1	master cylinder to LH 3 way union
3	3H2424	£7.80	UNION, 3 way	2	
4	GHF101	£0.28	SCREW, 'T' piece to bulkhead	2	
5	GHF331	£0.17	WASHER, locking	2	
6	GPP18AA	£12.20	BRAKE PIPE	1	3 way union to RH front hose
7	GPP20AA	£11.45	BRAKE PIPE	1	3 way union to LH front hose
8	GBH170	£6.50	BRAKE HOSE, front	2	drum brakes
	GBH170Z	£5.40	BRAKE HOSE, front, flexible	2	aftermarket
	GAC8412X	NCA	BRAKE HOSES, 4, stainless steel	1	front and rear
	MT5102	NCA	BRAKE HOSES, 2, stainless steel	1	front, (pair)
	MT5105	NCA	BRAKE HOSES, 5, stainless steel (Inc: GAC8447X clutch hose).	1	front and rear
	MT5401	NCA	BRAKE HOSES, 5, stainless steel (Includes GAC0080 clutch hose).	1	front and rear
9	GPP10AA	£11.75	BRAKE PIPE, wheel cyl. bridge pipe	2	
10	GPP122AD	NCA	BRAKE PIPE, RH	1	3 way union to LH rear connector
11	GPP118AD	NCA	BRAKE PIPE, LH	1	3 way union to RH rear connector
12	BMK2466A	£14.60	CONNECTOR, rear pipes	2	
13	GPP8CD	£8.20	BRAKE PIPE	2	rear connector to hose
14	GBH250	£4.96	BRAKE HOSE, rear	2	
	GBH250Z	£3.60	BRAKE HOSE, rear, flexible	2	aftermarket
	MT5101	£24.80	BRAKE HOSES, rear, stainless steel	1	pair
	MT5104	NCA	BRAKE HOSES, rear, stainless steel	1	pair, subframe to wheel cylinder
	NT606041	£0.54	NUT, locking, hose to radius arm	2	
	GHF323	£0.19	WASHER, locking	2	
	GHF202	£0.19	NUT	2	
15	GPP10AC	£11.75	BRAKE PIPE	2	rear hose to wheel cylinder

Brake Pipes For Diagonal Split System (LHD)

Note: With failure switch (illustrated)

16	GPP10AA	£11.75	BRAKE PIPE, RHD	1	
	GPP30TT	NCA	BRAKE PIPE, LHD	1	master cylinder to failure switch
17	GPP10AA	£11.75	BRAKE PIPE, RHD	1	
	GPP32AA	£13.66	BRAKE PIPE, LHD	1	
18	GPP17AA	NCA	BRAKE PIPE	1	failure switch to RH front hose

ill.	Part Number	Price £ea.	Description	Req.	Details
19	GPP29AA	NCA	BRAKE PIPE	1	failure switch to connector
20	BCA4002	£2.80	CONNECTOR	1	connector to LH front, (pair)
21	GPP17AA	NCA	BRAKE PIPE	1	connector to LH front hose
22	GBH170	£6.50	BRAKE HOSE, front	2	drum brakes
	GBH170Z	£5.40	BRAKE HOSE, front, flexible	2	aftermarket
	GBH249	£5.90	BRAKE HOSE, front	2	disc brakes
	MT5103	£51.80	BRAKE HOSES, 2, stainless steel	1	front, (pair)
	GAC8412X	NCA	BRAKE HOSES, 4, stainless steel	1	front and rear
	MT5102	NCA	BRAKE HOSES, 2, stainless steel	1	front, (pair)
	MT5105	NCA	BRAKE HOSES, 5, stainless steel (Including GAC8447X clutch hose).	1	front and rear
	MT5401	NCA	BRAKE HOSES, 5, stainless steel (Including GAC0080 clutch hose).	1	front and rear
23	GPP10AA	£11.75	BRAKE PIPE, wheel cylinder bridge	2	drum brakes only
24	GPP96CT	£14.90	BRAKE PIPE	1	failure switch to RH rear hose
25	GPP120CT	£21.95	BRAKE PIPE	1	failure switch to LH rear hose
26	GBH250	£4.96	BRAKE HOSE, rear	2	
	GBH250Z	£3.60	BRAKE HOSE, rear, flexible	2	aftermarket
	MT5101	£24.80	BRAKE HOSES, rear, stainless steel	1	(pair)
	MT5104	NCA	BRAKE HOSES, rear, stainless steel	1	(pair), subframe to wheel cylinder
27	GPP10CT	£11.75	BRAKE PIPE, rear hose to w/cyl	2	
28	13H5905	NCA	FAILURE SWITCH	1	
29	BAU1704A	£11.00	REPAIR KIT, failure switch	1	

Brake and Clutch Fluids

When Did You Last Change Your Brake Fluid?

DOT3 fluid ought to be completely discarded, DOT4 ('GBF4') should be installed and replaced every 2 years, as recommended by manufacturers. An alternative, especially if you are replacing master cylinders, brake calipers and/or wheel cylinders, is to thoroughly flush out the pipes and install Silicone fluid (DOT5 'ABF'), which is 'Non-Hygroscopic', so it doesn't promote rust problems in the hydraulic system. The bonus is that it won't damage paint work. When silicone is in use it will provide years of trouble free braking and an end to the monotonous and expensive pastime of repairing or replacing worn or leaking hydraulic components. Racing Fluid (DOT5.1 'GBF5') really is the ultimate in brake fluid. Its anti-boil properties mean that even when the brakes get hot the fluid will remain efficient, rather than boiling locally (such as in the calipers) into useless vapour. Ideal on the race track or when the brakes are used to their limits. Due to its high 'Hygroscopic' nature, DOT5.1 Racing fluid should be replaced annually otherwise the quality and effectiveness will be drastically reduced.

GBF4102	£6.50	BRAKE/CLUTCH FLUID, DOT4	a/r	500ml
GBF4103	£11.65	BRAKE/CLUTCH FLUID, DOT4	a/r	1 litre
GBF4104	£46.80	BRAKE/CLUTCH FLUID, DOT4	a/r	5 litre
ABF3	NCA	BRAKE/CLUTCH FLUID, DOT5	a/r	silicone 500ml
ABF4	NCA	BRAKE/CLUTCH FLUID, DOT5	a/r	silicone 1 litre
GBF5102	£8.10	BRAKE/CLUTCH FLUID, DOT5.1	a/r	racing 500ml
GBF5103	£15.14	BRAKE/CLUTCH FLUID, DOT5.1	a/r	racing 1 litre

Note: When bleeding the Minis brake system always start with the cylinder furthest away from the master cylinder, so for a RHD car this would mean start with the passenger side rear then the drivers side, keep the car as high as possible on the cylinder you are bleeding! Always use axle stands when working under your car, they may be little but they are still quite heavy, Safety first.

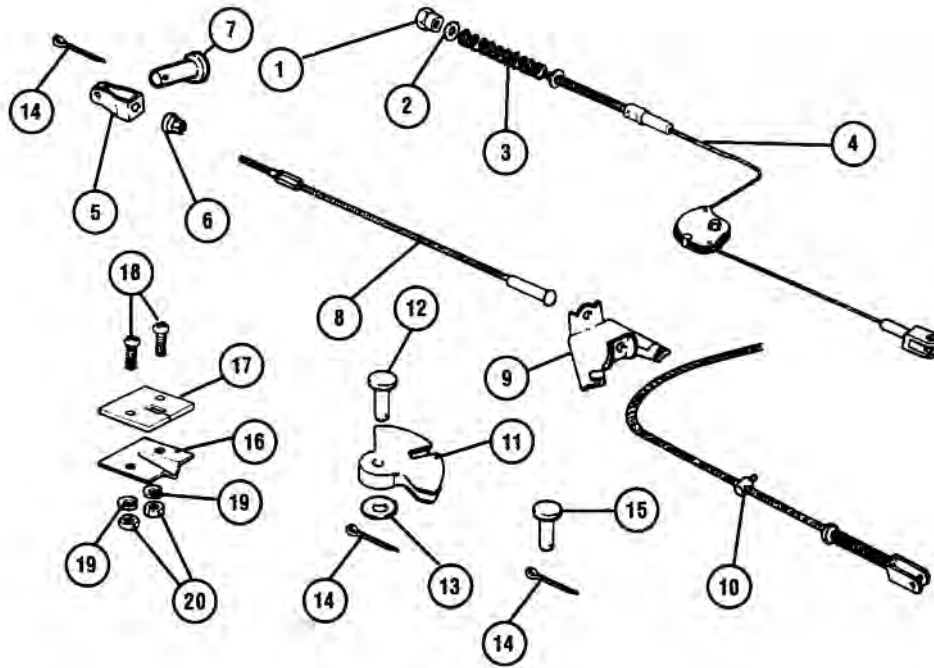

ill.	Part Number	Price £ea.	Description	Req.	Details
Handbrake Cables And Fittings					
1	2A5858	£2.57	NUT, cable adjusting*	1/2	
2	PWZ204	NCA	WASHER*	4	
3	ACH8508	£1.36	SPRING, adjuster tension*	1/2	
4	GVC1022	£3.68	CABLE, handbrake	2	twin cable system
	GVC1021	£4.98	CABLE, handbrake (Dry suspension saloon).	2	twin cable system
	GVC1020	£5.30	CABLE, handbrake (Hydrostatic suspension saloon). (Van, estate and pick up).	2	twin cable system
5	FAM628	£12.00	FORK, cable end	1	
6	31G5049	£4.56	NUT, cable adjusting	1	
7	CLZ513	£0.70	CLEVIS PIN	1	fork to handbrake lever
8	GVC1035	£4.80	CABLE	1	lever to compensator
	FAM625	£6.50	CABLE (Pick up, van or estate).	1	
9	FAM621	£25.70	COMPENSATOR	1	
10	GVC1034	£7.30	CABLE	1	between wheels
11	21A2454	£11.40	QUADRANT	2	
12	CLZ549	£5.20	CLEVIS PIN	2	
13	AWZ105	£0.42	WASHER, waved	2	
14	GHF502	£0.19	SPLIT PIN	2	For CLZ549
	GHF501	£0.42	SPLIT PIN	2	For CLZ409
15	CLZ409	£1.32	CLEVIS PIN	2	cablE to brake levers
16	ACA5522	£3.32	GUIDE, cable through floor*	1/2	
17	21A385	£2.23	SEAL, cable guide to floor*	1/2	
18	SE910201	£0.62	SCREW, guide retaining*	2/4	
19	WL700101	£0.19	WASHER, locking*	2/4	
20	GHF206	£0.13	NUT*	2/4	

*Note: Quantity increased when twin cables fitted to early cars.

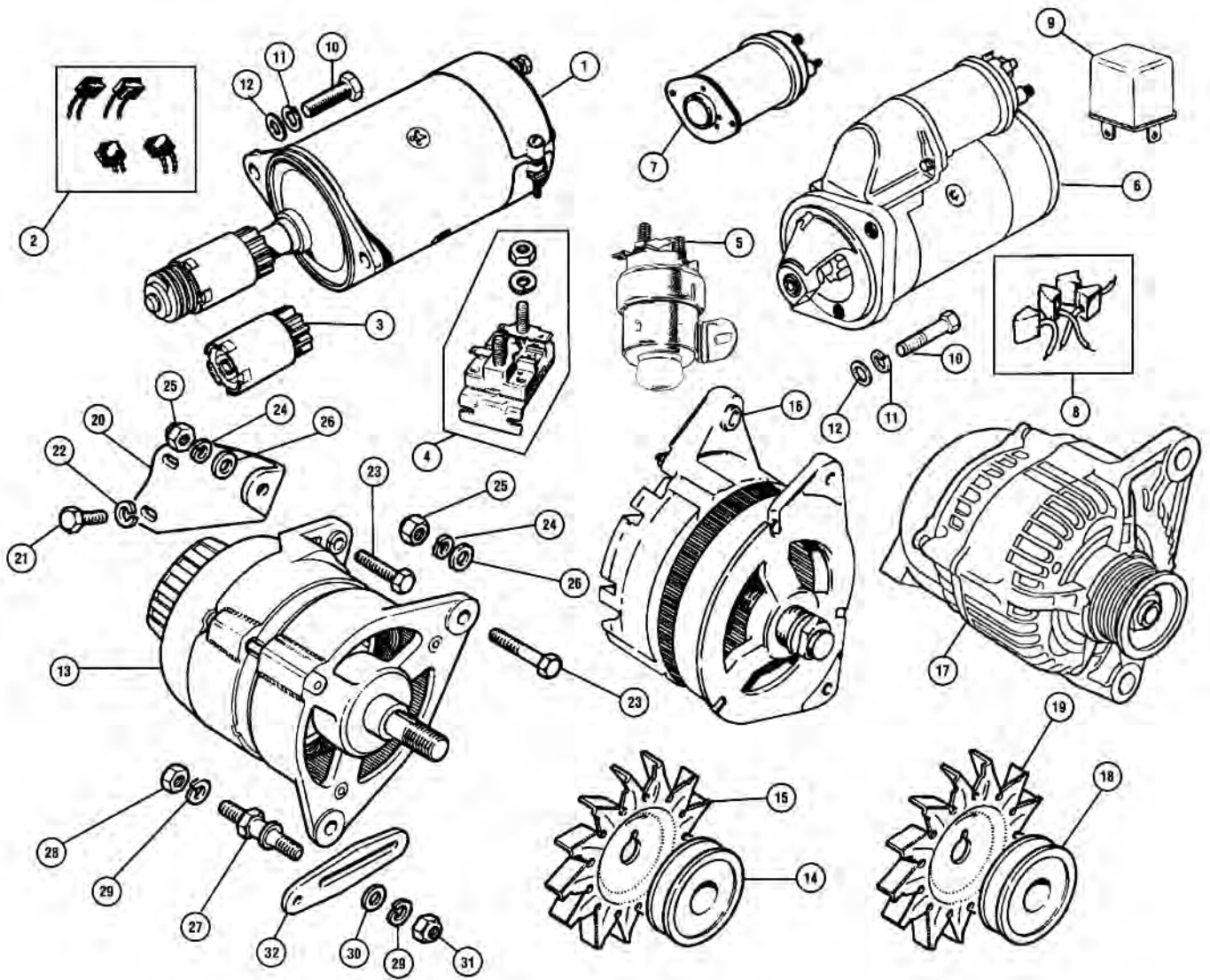

ill.	Part Number	Price £ea.	Description	Req.	Details
Starter Motors					
1	GEU9404	£90.00	STARTER MOTOR, inertia, new	1	To 1985
	GXE4404X	£222.80	STARTER MOTOR, high torque (Replaces inertia type starter motors. See the accessories section for more information).	1	To 1985
2	GSB105	£5.30	BRUSH SET, 35J type starter	1	
3	67H5010	£21.30	PINION, 9 teeth	1	} alternatives
	BAU5781	£30.50	PINION, 10 teeth	1	
4	13H5952	£9.00	SOLENOID, inertia starter	1	
5	BCA4501	£29.30	SOLENOID, inertia starter early	1	round push button
6	GXE4527	£87.40	STARTER MOTOR, pre-engaged	1	1985-On
	GXE4527X	£222.80	STARTER MOTOR, high torque (Replaces pre-engaged type starter motors. See the Accessories section for more information).	1	pre-engaged type
7	NAF10004	NCA	SOLENOID, pre-engaged starter	1	
8	BAU5448	NCA	BRUSH SET, pre-engaged starter	1	
9	YWB10032	£4.56	RELAY, pre engaged starter	1	
10	SH506101	£0.94	SCREW, starter to housing	2	
11	GHF332	£0.28	WASHER, locking	2	for both types
12	GHF302	£0.60	WASHER, plain	2	starter motor

Alternators

13	GEU2206	£65.30	ALTERNATOR, 18 ACR, new	1	} alternatives
	GXE8211	£55.00	ALTERNATOR, 17 ACR	1	
	GEU250	£4.50	PLUG, cable end	1	
14	12G1054	£14.95	PULLEY, 2.750" diameter	1	
	BAU1461A	£15.90	PULLEY, 2.500" diameter	1	
15	C37222A	£18.74	FAN, alternator	1	use with 12G1054 (ACR types: 23640, 23725, 23774, 23750, 23748 & 23804).
	AAU3956A	£12.00	FAN, alternator (ACR type: 23802).	1	use with BAU1461

ill.	Part Number	Price £ea.	Description	Req.	Details
16	GXE2257	NCA	ALTERNATOR, A115/45, rebuilt	1	1981-85
	GEU2297	£80.40	ALTERNATOR, A127/45, rebuilt	1	1985-On
17	GNU2521	£162.80	ALTERNATOR, multi groove belt	1	1996-On fitment mpi
18	BAU5819	£6.00	PULLEY, alternator, (A115/45)	1	use with GXE2257
	ADU7778	NCA	PULLEY, alternator, (A127/45)	1	use with GXE2297
	GCB10813	£5.42	ALTERNATOR BELT, (813mm long)	1	To 1985
	GCB10838	£4.63	ALTERNATOR BELT, (838mm long)	1	} A115 alternator } 1981-85
	GCB10825	£5.20	ALTERNATOR BELT, (825mm long)	1	
	GMB50920	£10.80	ALTERNATOR BELT, multi groove	1	mpi 1996-On
19	AAU3956A	£12.00	FAN, alternator, (A115/45)	1	use with GXE2257
	AUU1097	NCA	FAN, alternator, (A127/45)	1	use with GXE2297
20	12G1053	£9.50	BRACKET, rear mounting	1	pre A+ engines
	CAM4853	£12.60	BRACKET, rear mounting	1	A+ engines
21	GHF120	£0.28	SCREW, bracket to block	2	
22	GHF332	£0.28	WASHER, locking	2	
23	BH605131	£0.84	BOLT	2	} alternator to rear } bracket + water } pump
24	GHF332	£0.28	WASHER, locking	2	
25	GHF201	£0.12	NUT, plain 5/16" UNF	2	
26	WC108051	£0.28	WASHER, plain	1	
27	12G289	£6.90	PILLAR, adjustment link	1	pre A+ engines
	SH606111	£0.73	SCREW, 3/8"	1	A+ engines engine front plate to alternator link
	PWZ306	£0.42	SPACER, adjusting link	2	alternator link
28	GHF202	£0.19	NUT, plain, 3/8" UNF	2/1	quantity reduced
29	GHF333	£0.28	WASHER, locking	2/1	with SH606111
30	GHF302	£0.60	WASHER, plain	2/1	
31	GHF223	£0.48	NUT, nyloc	1	not used with SH606111
32	12G2627	£8.75	LINK, alternator adjustment	1	

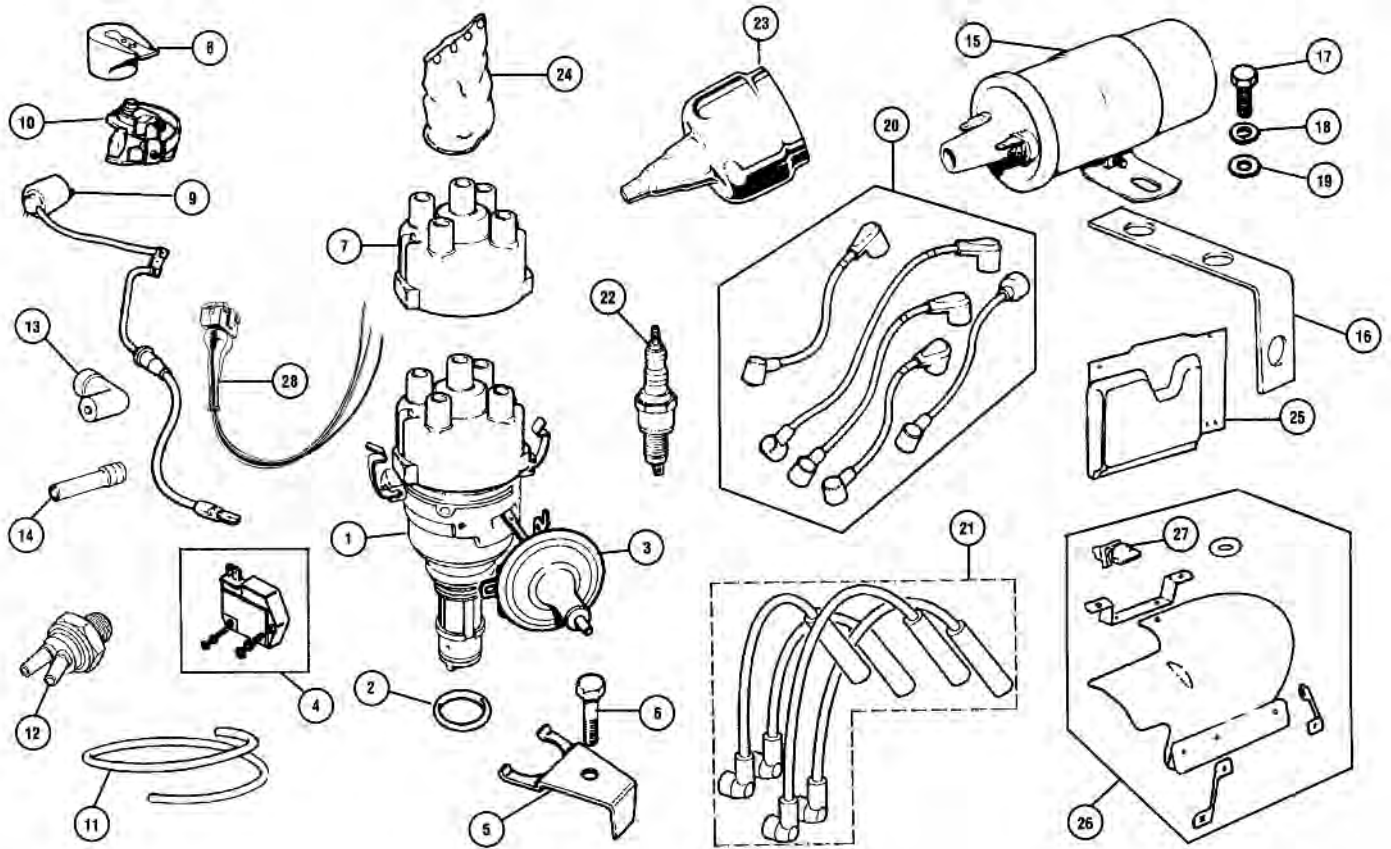

Part Number	Price £ea.	Description	Req.	Details
Distributors				
1	BAU1962	NCA DISTRIBUTOR (45D)	1	998cc pre A+
	ADU3766	NCA DISTRIBUTOR (45D)	1	998cc A+
	AAU9142	NCA DISTRIBUTOR (59D)	1	998cc A+ (For engine codes: 99H/791P/792P/A97P/B83P/B84P/B85P/D83P/E22).
	ADU4049	£100.00 DISTRIBUTOR (59D)	1	998cc A+ (For engine codes: 99H/997P/998P/A53P/A94P/B81P/B82P/C20P/D80P/D82P).
	ADU5789	£199.70 DISTRIBUTOR (59D)	1	998cc A+ lead free
	AUU1536	£80.00 DISTRIBUTOR, electronic	1	Cooper 1300cc + SE
	TMG10871	£200.00 DISTRIBUTOR	1	performance (Fast road ignition curve, with vacuum unit for A series only).
	TMG10873	£168.20 DISTRIBUTOR	1	performance (Fast road ignition curve, without vacuum unit for A series only, side entry cap fitted).
	TMG10869	£153.70 DISTRIBUTOR	1	performance (Fast road ignition curve, without vacuum unit for A series only).
	TMG10870	£140.10 DISTRIBUTOR	1	performance (Fast road ignition curve, without vacuum unit for A+ only).
2	513682A	£1.00 'O' RING, distributor	1	
3	37H8225	£25.00 VACUUM UNIT, Lucas	1	To 1976
	37H8414	£25.00 VACUUM UNIT, Lucas	1	1976-89 (Use with distributor AAU9142).
	37H8226	NCA VACUUM UNIT, Lucas	1	1980-89 (Use with distributor ADU4049 and ADU5789).
	BAU5252	NCA VACUUM UNIT, Ducellier	1	
	BAU5309	NCA VACUUM UNIT, Lucas	1	Cooper 1300cc (Use with distributor AUU1536).
4	NJL100060	£27.00 MODULE, electronic ignition	1	Cooper 1300cc + SE
5	613857A	£8.00 CLAMP, distributor	1	A To 1985
	TAM1671	£8.50 CLAMP, distributor	1	A+ 1985-On
6	CAM6105	NCA BOLT, distributor clamp	1	A To 1985
	TAM1706	£1.66 BOLT, distributor clamp	1	A+ 1985-On

Ignition System Service Parts

Part Number	Price £ea.	Description	Req.	Details
7	GDC136	£4.80 CAP, distributor	1	Lucas 45D and 59D
	GDC142	£7.00 CAP, distributor side entry	1	Lucas 45D and 59D
	GDC214	£13.50 CAP, distributor	1	Ducellier distributor

Note: The side entry push fit cap, GDC142 requires slight modification to fit. The two screws need to be removed and a groove filed. Fits 45D distributors with a clip retained cap GDC136.

Part Number	Price £ea.	Description	Req.	Details
	GDC156	£3.08 CAP, distributor	1	Cooper 1300cc + SE
	GDC156CLEAR	NCA CAP, distributor	1	Cooper 1300cc A+ SE, clear
8	GRA2114	£2.86 ROTOR ARM	1	Lucas 45D and 49D
	GRA2114HQ	£6.95 ROTOR ARM, high quality	1	
	GRA123	£2.86 ROTOR ARM	1	Ducellier distributor
	GRA2123B	NCA ROTOR ARM	1	Ducellier distributor
	GRA2143	£2.86 ROTOR ARM	1	Cooper 1300cc + SE
9	GSC2109	£2.95 CONDENSER	1	Lucas 45D and 59D
	GSC113	NCA CONDENSER	1	Ducellier distributor
	GCS118	£3.76 CONTACT SET	1	Lucas 45D
	GCS119	£5.65 CONTACT SET	1	Ducellier distributor
	GCS124	£4.24 CONTACT SET	1	Lucas 59D
11	37H4229M	£1.60 VACUUM PIPE	1	sold per metre
12	MAQ10008	NCA VACUUM SWITCH	1	1992-On (This thermostatically controlled vacuum switch fits in thermostat housing).
13	12B2062	£1.36 CONNECTOR, vacuum pipe	1	angled
14	12B2095	£1.90 CONNECTOR, vacuum pipe	1	straight
15	GCL110	£13.85 COIL	1	To 1982
	GCL132	£11.90 COIL, Ballast resistor	1	all 1982-On
	GCL143	£17.10 COIL, electronic	1	
	GCL204	£38.00 COIL, coil pack	1	1996-On mpi
16	12G2994	£9.00 BRACKET, coil mounting to head	1	Lucas coil
17	SH605041	£0.32 SCREW, coil to bracket	2	
18	GHF332	£0.28 WASHER, locking	2	
19	WC108051	£0.28 WASHER, plain	2	
20	GHT7003	NCA HT LEAD, right angle	4	1968-69
	GHT241	£14.40 HT LEAD SET	1	1275cc
	GHT289	£21.80 HT LEAD SET	1	1996-On mpi
22	BP6ES	£3.30 SPARK PLUG, non resistor	4	998cc To 1986
	BP5ES	£3.79 SPARK PLUG, non resistor	4	998cc 1987 To September 1989
	BPR4ES	£4.96 SPARK PLUG, resistor, lead free	4	998cc October 1989-On
	BPR6ES	£5.15 SPARK PLUG, resistor	4	1275cc Cooper carburettor and TBI
23	8G727	£5.40 COVER, coil	1	not fitted as standard
24	AUU1104	NCA COVER, distributor	1	VIN 315055
25	BHM773	£29.10 COVER, moulded plastic, grille	1	van
26	BHM1675	£105.20 SHIELD KIT, ignition system	1	From VIN 315056
	BHM1676	£21.50 SHIELD KIT, ignition system	1	
	NJT10004	£34.00 SHIELD KIT, ignition system	1	Cooper SE + 1300cc
	GDS102A	£11.90 SHIELD KIT, ignition system	1	small saloon
27	13H6461	£4.50 TURN BUTTON, shield retaining	3	
28	54966877	£6.76 PLUG & LEAD, electronic module	1	Cooper 1300

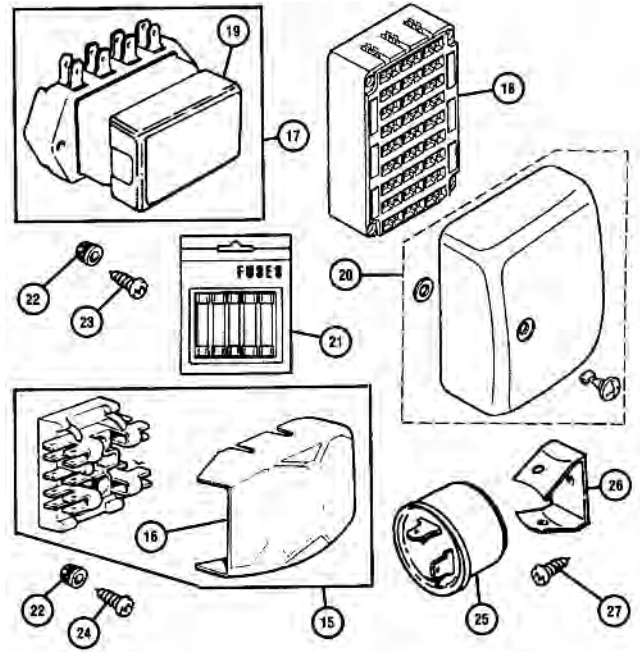
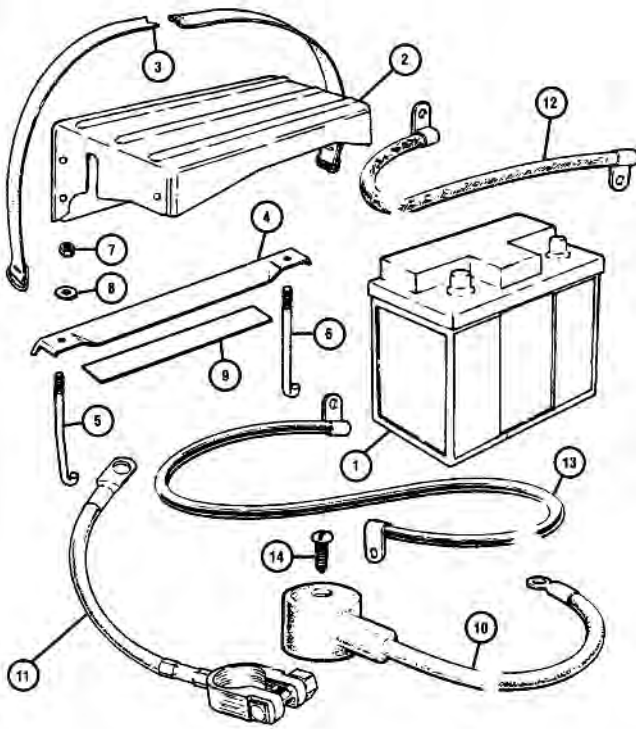

iii. Part Number Price £ea. Description Req. Details

Batteries and Cables

1	GBY5601D	£90.00	BATTERY, 12 volt, 30 A/hr, dry	1	
	GBY5601W	£90.00	BATTERY, 12 volt, 30 A/hr, wet	1	
2	5L877	£21.90	COVER, battery	1	
3	14A7776	£9.00	STRAP, battery cover retaining	1	
4	HAM2457	£8.90	BAR, battery retaining	1	
5	5L1158	£1.96	HOOK BOLT, rear, 2 1/8"	1	
	YJH100010	£1.80	HOOK BOLT, rear, 3"	1	
6	5L1159	£1.80	HOOK BOLT, front, 2 1/8"	1	
	YJJ100040	£1.86	HOOK BOLT, front, 3"	1	
7	GHF200	£0.19	NUT, hook bolt	4	
8	GHF300	£0.19	WASHER, plain	2	
9	078447A	£4.70	PACKING STRIP	1	cut to length
10	5L885	NCA	CABLE, battery to solenoid	1	inertia starters
	AUU1089	£43.90	CABLE, battery to solenoid	1	pre engaged starters
11	5L924	£13.00	CABLE, battery earth	1	
12	YMS10090	£5.90	CABLE, engine earth	1	
13	5L925	£8.00	CABLE, solenoid to starter	1	inertia starters only
14	2K8645	£0.24	SCREW, cable to battery terminal	1	
	GHF2750	£5.22	CLAMP, battery terminal, -VE	1	
	GHF2755	£5.22	CLAMP, battery terminal, +VE	1	

Note: To ensure good reliability of your Mini make sure the earth leads are in good condition. A damaged or old earth lead can be a major source of problem on the Mini, bad starting and sticky Throttle cables are quite common due to a neglected earth cable.

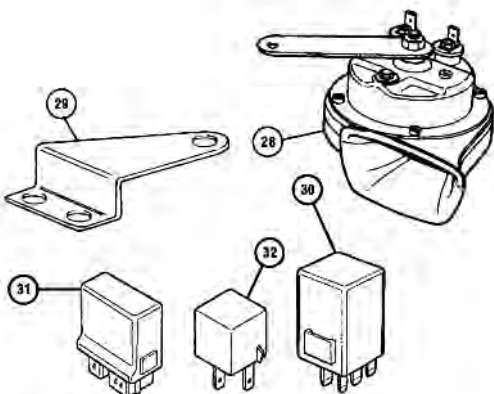

iii. Part Number Price £ea. Description Req. Details

Fuse Box, Fuses and Flasher Units

15	606253A	£12.05	FUSE BOX, (2 fuses required)*	1	To 1976
16	505158A	£4.44	COVER, fuse box	1	
17	RTC440A	£18.00	FUSE BOX, (4 fuses required)*	1	1976-On
18	AFU3103	NCA	FUSE BOX	1	1996-On mpi (Located inside car under dash in drivers footwell).
*Note: Fuse boxes do not come with fuses.					
19	37H4727A	£2.00	COVER, fuse box	1	
	BST440	£22.60	COVER, fuse box, stainless steel	1	
20	YQH100720PMA	NCA	COVER, fuse box	1	1996-On mpi
21	GFS3015	£1.66	FUSES, 15A, pack of five	1	as required
	GFS3025	£2.05	FUSES, 25A, pack of five	1	
	GFS3035	£2.05	FUSES, 35A, pack of five	1	
22	GHF1030	£0.54	NUT, insert in bulkhead	1/2	(Qty. increased for fuse box RTC440A).
23	AB610081	£0.37	SCREW, self tapping	2	use with RTC440A
24	AB608031	£0.19	SCREW, self tapping	1	use with 606253A
25	GFU2124	£4.32	FLASHER UNIT	1	cars with or without repeater lamps
	GFU2204	£4.60	FLASHER UNIT, hazard lights	1	
	GFU2218	£5.12	FLASHER UNIT	1	two pin
	GFU2208	£14.00	FLASHER UNIT	1	three pin hazard warning
26	BHA4780	£2.80	CLIP, square flasher unit	a/r	
27	GHF425	£0.19	SCREW, clip to bulkhead	a/r	

iii. Part Number Price £ea. Description Req. Details

Horns

Note: R-Numbering of horns.

28	GGE101	£12.70	HORN, high tone, single terminal	1	France, To VIN 175685
	GGE164	£10.20	HORN, high tone, twin terminal	1	
	GGE165	£10.20	HORN, low tone, twin terminal	1	
	MT9143	£16.70	HORN, Chrome, twin terminal	1	
29	57H5309	£4.55	BRACKET	1	To VIN175685

Note: Brackets may require modification due to metric threads on horns.

30	YWC10050	£18.00	RELAY, dim dip control	1	
31	YWB10022	£160.10	RELAY, spi and mpi	1	engine management relay
32	YWB10012	£10.00	RELAY, multi use	a/r	(Headlamps, horn, driving lamps, direction indicator lamps).

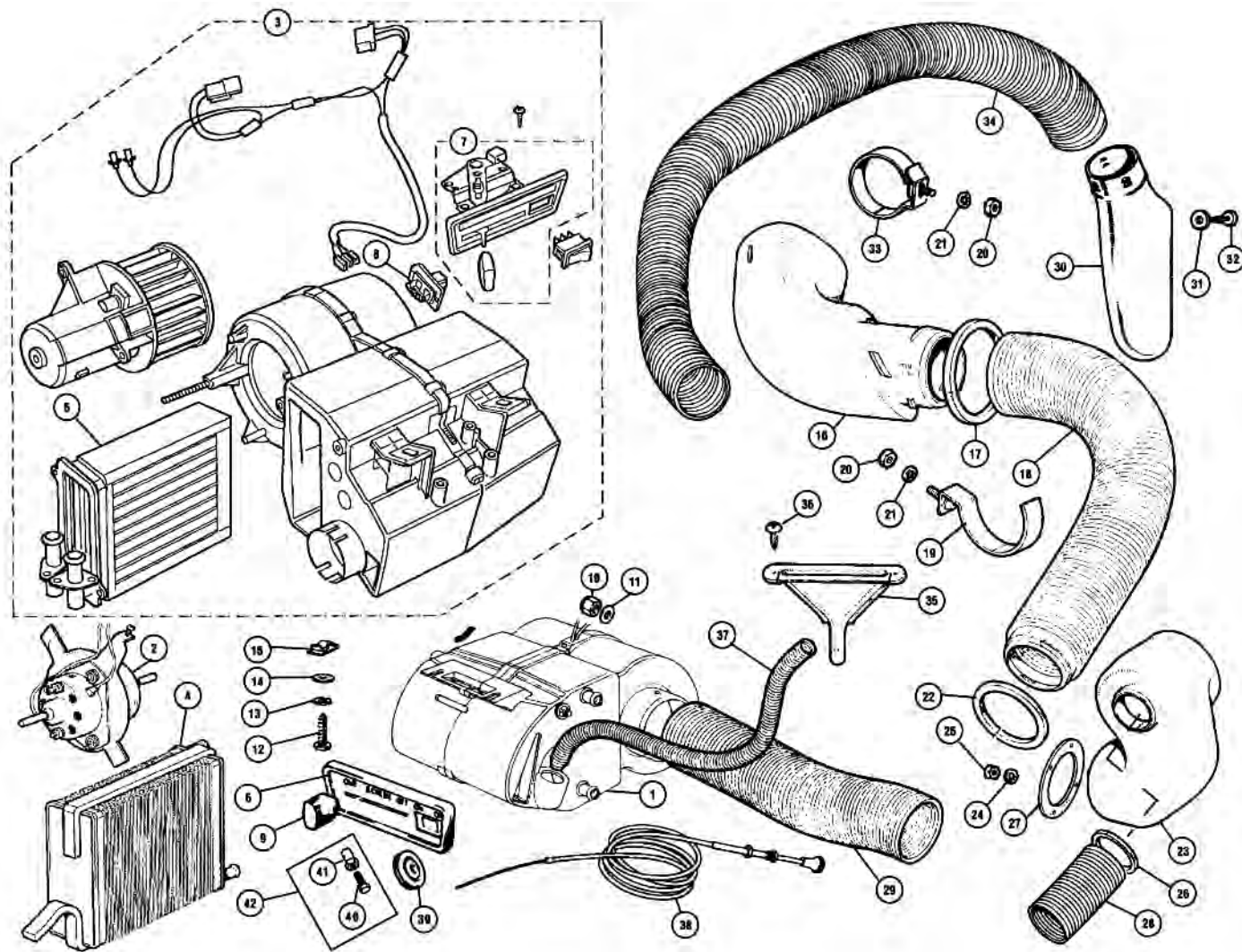

ill.	Part Number	Price £ea.	Description	Req.	Details
Heater Unit And Ducting					
1	JGC10008	NCA	MOTOR, with fan	1	To VIN 073750
2	JGC100110	NCA	MOTOR, with fan	1	From VIN 073751
3	JEC101790	NCA	MOTOR, twin speed, with fan	1	mpi From VIN 134455
4	37H216	£80.10	HEATER MATRIX, 0.50" bore	1	To VIN 212068
	BAU5043	£47.80	HEATER MATRIX, 0.625" bore	1	From VIN 212069
5	JEF10005	£78.00	HEATER MATRIX, 0.625" bore	1	plastic casing (Inlet and outlet unions are not supplied with matrix).
	JEP10008	£32.80	OUTLET PIPES, heater matrix	1	for JEF10005
6	BAU1924	NCA	CONTROL PANEL, air distribution	1	fits all
7	JFC101620PMA	NCA	CONTROL PANEL, air distribution	1	1996-On mpi
8	JGM100100	NCA	RESISTOR, speed controller	1	1996-On mpi (For twin speed heater JEC101790).
9	BAU1923	NCA	KNOB, air distribution control	1	
10	GHF243	£1.00	NUT, heater to bulkhead	2	
11	GHF302	£0.60	WASHER, plain, for above	2	
12	AB610071	£0.62	SCREW, heater to parcel shelf	2	
13	WL700101	£0.19	WASHER, locking	2	
14	GHF306	£0.28	WASHER, plain	2	
15	GHF713	£0.37	SPIRE NUT	2	
16	JKA10012	NCA	DUCT, air intake behind grille, RH	1	
17	JPC6876	NCA	SEAL, duct to flitch	1	
18	EAM7437	NCA	HOSE, duct to air box	1	
19	AHH5714	£2.57	CLIP, air hose to flitch	1	To VIN 290002
	JCG10001	NCA	CLIP, air hose to flitch	1	From VIN 290003
20	GHF200	£0.19	NUT	2	
21	WE702101	£0.28	WASHER, locking	2	
22	CZH1717	NCA	SEAL, hose to air box	1	To VIN 336452
	JPC6876	NCA	SEAL, hose to air box	1	From VIN 336543
23	CZH1951	NCA	AIR BOX, no face vents	1	
	CZH1755	NCA	AIR BOX, with face vents	1	To VIN 504653
	JKQ10002	NCA	AIR BOX, with face vents	1	From VIN 504654
24	WE702101	£0.28	WASHER, locking	4	
25	ANZ103	£1.15	NUT	4	
26	CZH693	NCA	SEAL, air box to face vent	1	
27	CZH1717	NCA	SEAL, air box to flitch	1	To VIN 336542
	JPC6877	NCA	SEAL, air box to flitch	1	From VIN 336543

ill.	Part Number	Price £ea.	Description	Req.	Details
28	CZH700	NCA	HOSE, air box to RH face vent	1	
29	346999A	£12.00	HOSE, air box to heater	1	
30	CZH1318	NCA	DUCT, air intake, LH	1	
31	GHF306	£0.28	WASHER	3	
32	AB608031	£0.19	SCREW, self tapping	3	air intake to front panel
33	JCG10001	NCA	CLIP, HOSE LH	1	
34	EAM7097	NCA	HOSE, nozzle to face vent, LH	1	From VIN 073751 To 5740
	627527	£10.40	HOSE, nozzle to face vent, LH	1	alternative
	JKC10025	NCA	NOZZLE, screen demister	2	To VIN 073750
	JKC10025	NCA	NOZZLE, screen demister	2	From VIN 073751 To 5740
36	AB610051	£0.28	SCREW, nozzle to dash	4	From VIN 073751 To 5740
37	CZH1753	£31.60	HOSE, heater to nozzle	2	To VIN 073750
	JKC10024	£20.10	HOSE, heater to nozzle	2	From VIN 073751 To 5740
38	14A9988	£30.00	CABLE, heater	1	original Bakerlite type knob
	MCR101	£16.70	CABLE, heater, 30"	1	
	MCR102	£19.63	CABLE, heater, 30"	1	From VIN 369449 To VIN 463230
	MCR103	£20.16	CABLE, heater, 30", (less motif)	1	From VIN 463231 not TBI
	JFD10039	£4.44	MOTIF, knob, (for above)	1	
	JFF10051	£13.20	CABLE, heater, 40"	1	1991-On
	JFF100910	£76.10	CABLE, heater	1	mpi, remote heating valve
	MCR101	£16.70	CABLE, heater	1	To 1989
	MCR102	£19.63	CABLE, heater	1	1989-On option for JFF10003
	MCR103	£20.16	CABLE, heater	1	30" option for JFF10048
39	CAM5969	£2.00	GROMMET	1	cable through bulkhead
40	53K1016	£0.60	SCREW, cable to water valve	1	tap on head
41	24G1482	NCA	TRUNNION, cable end	1	
42	24G1482K	£2.05	TRUNNION KIT, cable end	1	remote tap

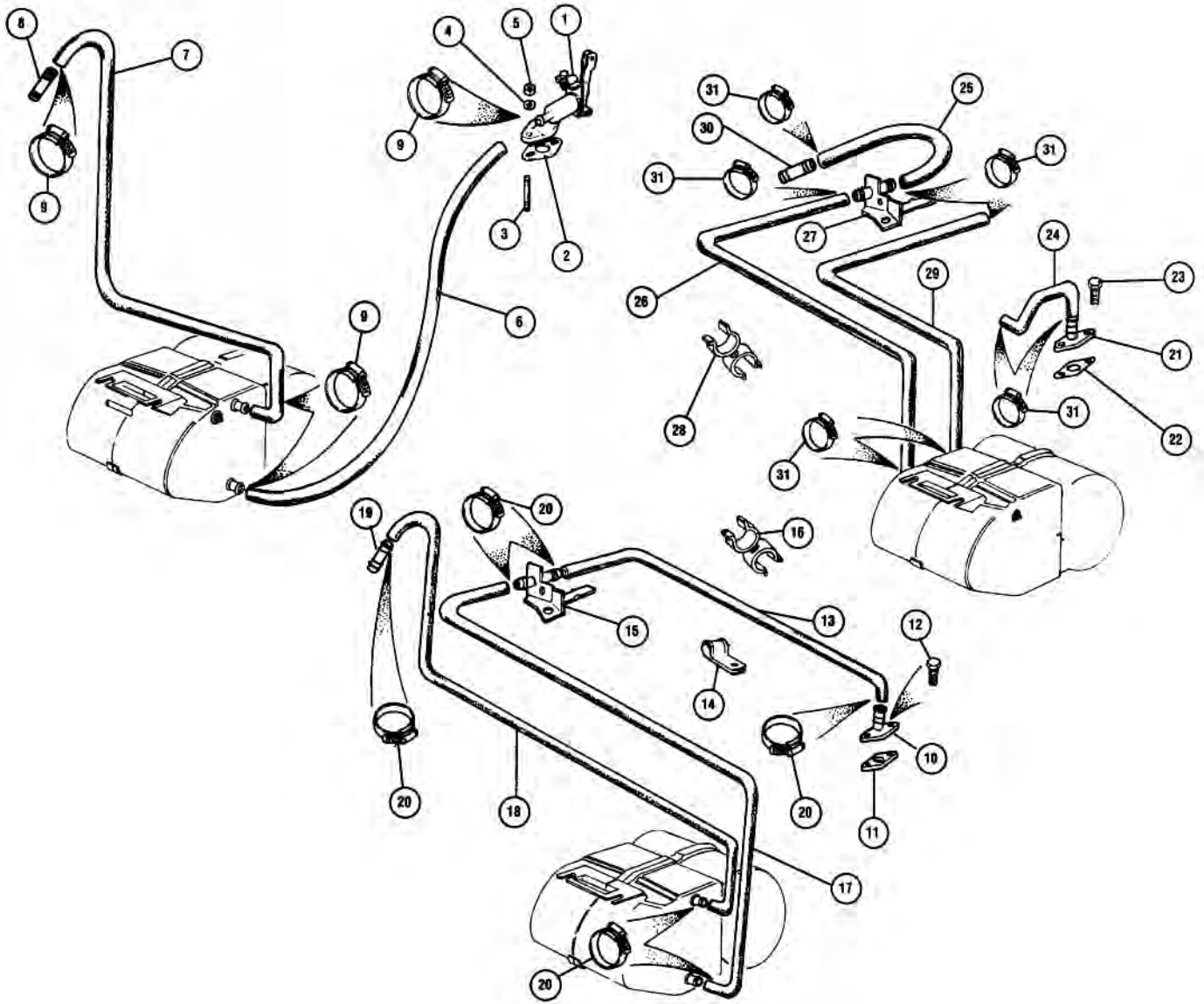

Part Number	Price £ea.	Description	Req.	Details
Heater Hoses				
Heater Hoses & Taps To VIN 396448				
1	ADU9102	NCA HEATER VALVE, angled type	1	
	ADU9102Z	£19.90 HEATER VALVE, angled type	1	aftermarket
	JJC10018	£33.60 HEATER VALVE, straight type	1	Morris Minor fitment
	2A180	£3.80 BLANKING PLUG	1	when water valve not fitted
2	88G221	£0.40 GASKET, heater tap	1	
3	53K402	£1.50 STUD, heater tap	2	
4	GHF331	£0.17 WASHER, locking	2	
5	GHF200	£0.19 NUT	2	
6	GRH1006M	£6.14 HOSE, valve to heater	1	1974-89 per metre (0.50" bore, cut to length RHD = 29" and LHD = 26").
7	602057	£17.40 HOSE, heater return 0.50 bore	1	aftermarket

Note: (0.50" bore) for LHD cut to 35" length.

6	BMP366	NCA HOSE, inlet RHD & LHD (Stepped bore 0.5"/0.625", cut to length RHD = 29" and LHD = 26").	1	1984-89
7	GRH905	£6.14 HOSE, heater return RHD (Stepped bore 0.5"/0.625").	1	1984-89
	BMP366	NCA HOSE, heater return LHD (Stepped bore 0.5"/0.625").	1	1984-89
8	CAM4412Z	NCA CONNECTOR, heater hose	1	return to bottom hose
9	GHC11022	£2.05 CLIP, hose, 0.500"	a/r	
	GHC11030	£2.45 CLIP, hose, 0.625"	a/r	

Heater Hoses From VIN 396449 On

10	12G2534	£24.00 WATER OUTLET, cylinder head	1	
----	---------	------------------------------------	---	--

Part Number	Price £ea.	Description	Req.	Details
11	88G221	£0.40 GASKET, water outlet to cylinder head	1	
12	TAM1368	NCA SCREW, water outlet to cylinder head	2	
13	NAM8677	NCA HOSE, outlet to water valve	1	
14	PEU10016	£2.32 CLIP, heater hose to rocker cover	1	
15	JJB10011	£31.70 WATER VALVE, remote mounted	1	
	JJB100260	£36.10 WATER VALVE, remote mounted	1	mpi
16	CDU2153	NCA CLIP, hose to hose	1	
17	JHB10002	£11.65 HOSE, valve to heater In	1	998cc models
18	JHC10004	£29.60 HOSE, heater return	1	To VIN504670
17	GRH1211	£28.50 HOSE, valve to heater In	1	998cc models
18	GRH1219	NCA HOSE, heater return	1	From VIN504671
19	PCP10006	£19.80 CONNECTOR	1	heater return to bottom hose
20	GHC11030	£2.45 CLIP, hose 0.625"	a/r	

Heater Hoses Cooper 1300 Models

21	12G2534	£24.00 WATER OUTLET, cylinder head	1	
22	88G221	£0.40 GASKET, water outlet to cylinder head	1	
23	TAM1368	NCA SCREW, water outlet to cylinder head	2	
24	PEH10021	NCA HOSE, water outlet to manifold	1	
25	GRH1006M	£6.14 HOSE, alternative, CTF	1	manifold to valve and bottom hose
26	JHB10017	NCA HOSE, heater outlet to valve	1	To VIN031529
27	JJB10011	£31.70 WATER VALVE, remote mounted	1	To VIN134454
	JJB100260	£36.10 WATER VALVE, remote mounted	1	From VIN134455
28	CDU2153	NCA CLIP, hose to hose	1	
29	JHC10004	£29.60 HOSE, thermostat to heater, RHD	1	
	JHC10007	NCA HOSE, thermostat to heater, LHD	1	
30	PCP10006	£19.80 CONNECTOR	1	To VIN504670
		(Heater return to bottom hose).		
	PCP10095	NCA CONNECTOR	1	From VIN504671
		(Heater return to bottom hose).		
31	GHC11030	£2.45 CLIP, hose 0.625"	a/r	

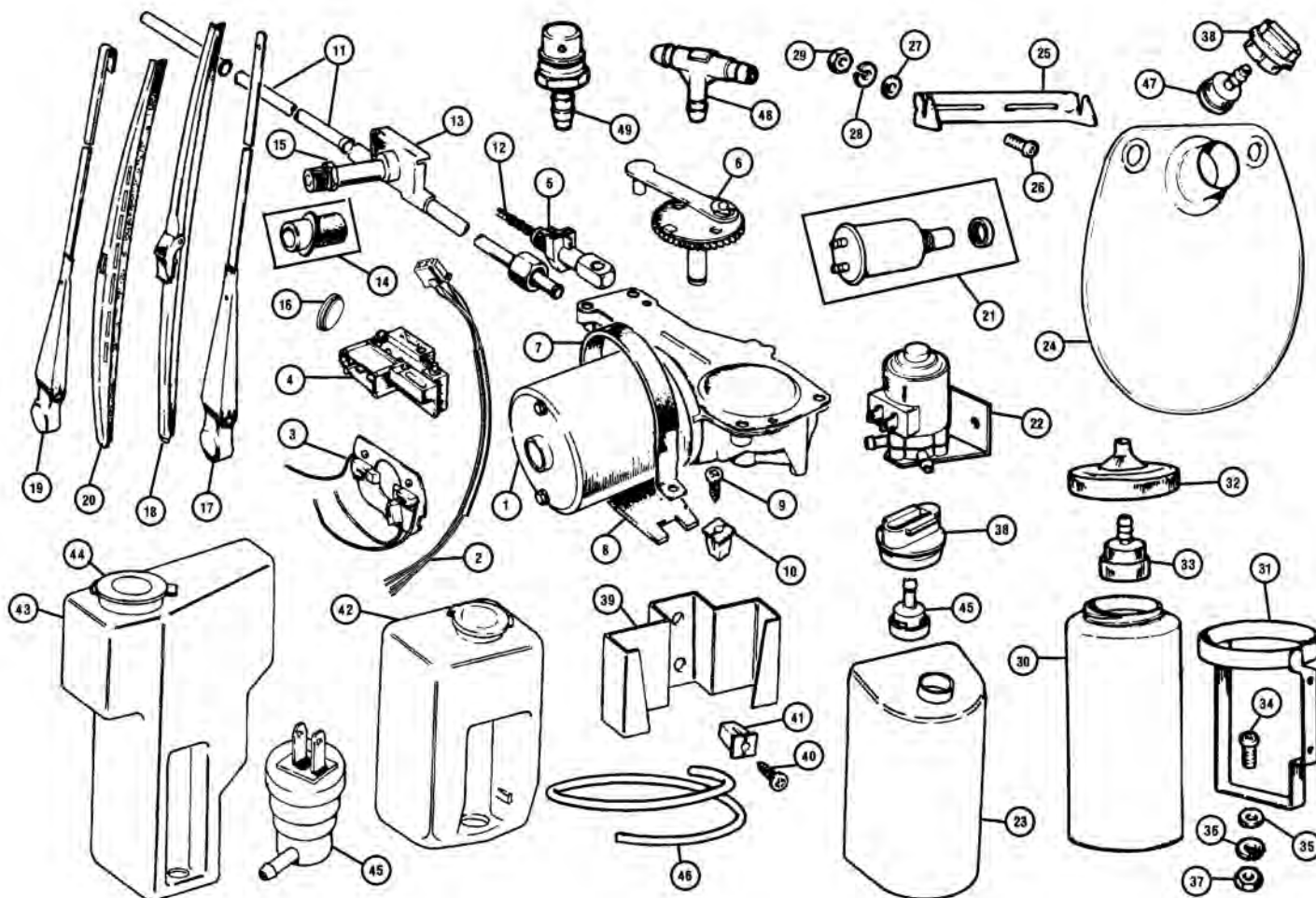

Part Number	Price £ea.	Description	Req.	Details
Windscreen Wiper System				
1 GXE7708	£48.00	WIPER MOTOR, new	1	less drive gear
2 GXE7708P	£8.80	PLUG & LEAD, wiper motor wiring	1	
Note: Due to the motor assembly being used in many different cars, the drive gear is not supplied with an exchange assembly, it must be retained from the original.				
3 RTC198A	£12.90	BRUSH KIT	1	
4 520160A	£20.00	PARK SWITCH	1	
5 37H3694	£2.23	FERRULE, wiper motor	1	
6 608092A	£34.90	GEAR, (110 degree), 46 teeth	1	
7 37H4836SS	£10.70	STRAP, motor to bulkhead	1	stainless steel
8 150844A	£1.92	PAD, wiper motor to bulkhead	1	
9 AB612051	£1.92	SCREW, strap retaining	2	self tapping
SE604051	£1.92	SCREW, strap retaining	2	machine thread
GHF300	£1.92	WASHER, plain	2	not illustrated
10 GHF1029	£1.92	NUT, insert in bulkhead	2	
11 AAU1909A	£1.92	TUBE KIT, wiper rack guide	1	cut and flare to fit
12 RTC202A	£1.92	WIPER RACK	1	cut to fit
13 37H7200	£1.92	WIPER WHEEL BOX	2	1971-On
14 37H7201	£1.92	WIPER BUSH KIT	2	
15 17H8769	£1.92	WIPER WHEEL BOX NUT	2	
16 14A7091	£1.92	PLUG, unused wiper Holes	2	
WPA9022X	£1.92	WIPER ARMS AND BLADES KIT, RHD	1	inc: GWB219 x2 and 13H5629 x2
WPA9023X	£1.92	WIPER ARMS AND BLADES KIT, LHD	1	inc: GWB219 x2 and 13H5626 x2
17 13H5629	£1.92	WIPER ARM, s/steel, LH side, RHD	2	
13H5626	£1.92	WIPER ARM, s/steel, RH side, LHD	2	
CZH4331	£1.92	WIPER ARM, black, LH side, RHD	2	
CZH4173	£1.92	WIPER ARM, black, RH side, LHD	2	
18 GWB219	£1.92	BLADE, wiper, stainless steel	2	
GWB219Z	£1.92	BLADE, wiper, stainless steel	2	
GWB911	£1.92	BLADE, wiper, black	2	
19 DKB101480	£1.92	WIPER ARM, hook fitting, RHD	2	
DKB101490	£1.92	WIPER ARM, hook fitting, LHD	2	1990-On
20 GWB911	£1.92	BLADE, wiper, hook fitting	2	

Part Number	Price £ea.	Description	Req.	Details
21 GWW102	£18.00	WASHER PUMP, manual	1	
GWW102B	£21.60	WASHER PUMP, manual, plastic	1	
22 GWW125	£9.90	WASHER PUMP, electric	1	remote mounted 1976 To VIN107477
GWW1069	NCA	WASHER PUMP, electric	1	
GWW1192	£17.70	WASHER PUMP, electric	1	1989-On
23 GWW906	£14.40	BOTTLE, 1 litre	1	bulkhead mounted
24 GWW917	£17.10	WASHER POUCH	1	fitted to early Minis
GWW917X	£22.60	WASHER POUCH, including motor	1	fitted to early Minis
25 BHA4919	£7.90	BRACKET, washer pouch	1	
26 PMZ308	£0.28	SCREW	2	
27 GHF306	£0.28	WASHER, flat	2	
28 WL700101	£0.19	WASHER, spring	2	
29 GHF206	£0.13	NUT	2	
30 GWW918K	£9.30	WASHER BOTTLE, with lid	1	plastic, Mkl & MklI
31 13H232	£6.40	BRACKET, washer bottle	1	
13H232SS	£8.00	BRACKET, washer bottle	1	stainless steel
32 AHG6848	£4.50	TOP WASHER BOTTLE	1	
33 GWW506	£1.92	FOOT, VALVE	1	
43 PMZ306	£0.42	SCREW	2	
35 PWZ203	£0.17	WASHER, flat	2	
36 WL700101	£0.19	WASHER, spring	2	
37 GHF206	£0.13	NUT	2	
38 GWW951	£2.05	CAP	1	
39 CZH1624	£6.66	BRACKET	1	
40 GHF423	£0.28	SCREW, bracket to bulkhead	2	
41 GHF1030	£0.54	NUT, insert in bulkhead	2	
42 GWW935	NCA	BOTTLE & CAP (Mounted on fliitch)	1	VIN 107478 To 396448
43 GWW940	£49.90	BOTTLE & CAP (Mounted on fliitch, direct acting servo).	1	VIN 396449 To 504653
44 GWW973	NCA	CAP, washer bottle	1	
45 GWW130	£8.50	WASHER PUMP, fitted in bottle	1	
46 GWW202M	£1.15	TUBING	a/r	per metre
47 GWW601	£5.00	VALVE, in bottle	1	
48 GWW401	£1.42	T-PIECE	1	1980-On
49 GWW804	£3.38	JET, black plastic	2	MkIII, to 1978
GWW829	£2.30	JET, black plastic	2	1978-On

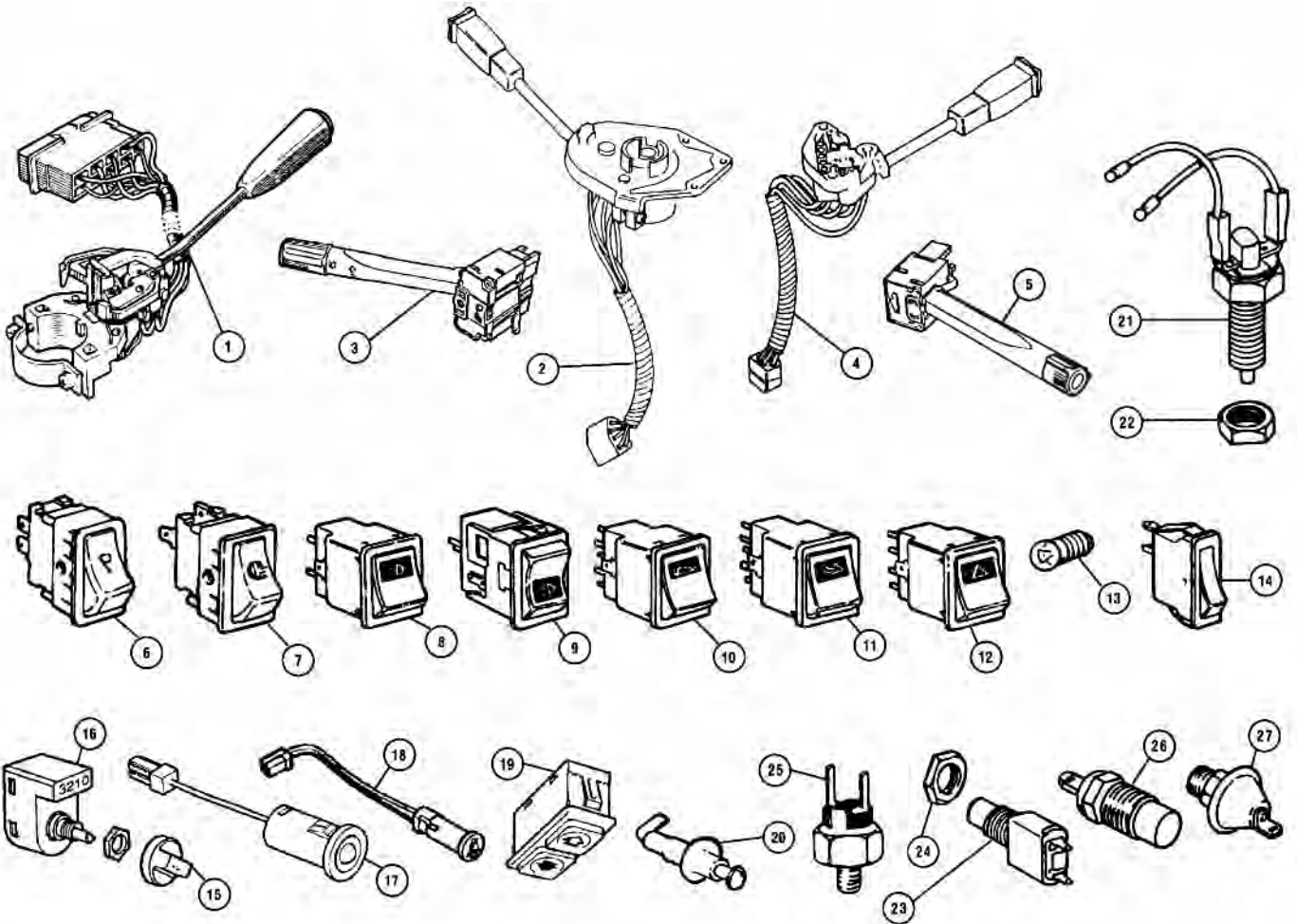

ill.	Part Number	Price £ea.	Description	Req.	Details
Column Switches					
1	2A6215	£62.00	SWITCH, indicator	1	Mkl with indicator warning lamp on the end of stalk
	47H5200	£1.56	LENS, green	1	for Mkl indicator warning lamp
	13H7779	£49.10	SWITCH, indicator with horn and dip	1	To 1976
2	21A2658	£36.50	SWITCH, indicator, RH side	1	RHD, 1976 To VIN 196212
	21A2660	£36.00	SWITCH, indicator, LH side	1	From VIN 196213-290002
	BAU5345	£35.00	SWITCH, indicator, LH side	1	VIN290003 On
3	XPC100200PMP	£132.00	SWITCH, indicator, LH side	1	1996-On mpi
4	37H8285	£24.76	SWITCH, wipers, LH side	1	RHD, 1976 To VIN196212
	37H8286	£49.10	SWITCH, wipers, RH side	1	From 196212-290002
	BAU5346	£15.00	SWITCH, wipers, RH side	1	VIN290003 On
5	XPE100420PMP	£77.00	SWITCH, wipers, RH side	1	1996-On mpi

Note: For manual washer pump fitted prior to 1976 please see windscreen wiper system section.

Note: Between 1976 & 1984 BL Cars bought switches from both Lucas and Bonnella. Only Lucas switches are currently supplied, so when replacing a Bonnella switch both Lucas switches must be purchased as the two makes are not compatible. To quickly identify which is fitted to your car, Lucas type wash/wipe is fitted to the indicator switch by a hex-headed self tapping screw whereas the Bonnella type is riveted.

Dash Switches

6	13H6343	£11.70	SWITCH, wipers, single speed	1	Lucas terminals
	BHA5110	£11.95	SWITCH, wipers, two speed	1	To 1976
7	13H6342	£29.30	SWITCH, lights	1	
8	YUF101030	£11.00	SWITCH, lights	1	

ill.	Part Number	Price £ea.	Description	Req.	Details
9	ADU4791	NCA	SWITCH, fog lights	1	
	YUF000110	£11.30	SWITCH, fog lights	1	
10	YUF101680	£10.80	SWITCH, heated rear screen	1	pin terminals
11	ADU4794	NCA	SWITCH, brake check switch	1	1976-On
	YUF101650	£11.10	SWITCH, brake check switch	1	
12	13H8725	NCA	SWITCH, hazards	1	
	YUF101660	£14.30	SWITCH, hazards	1	
13	GLB280	£1.45	BULB, illuminating switches	a/r	
14	YUF101090	£7.90	SWITCH, heater control	1	
15	YUM10002	£1.92	KNOB, rotary switch	1	
16	YUK100140	NCA	SWITCH, headlamp level	1	rotary switch
17	YWN10002	£14.60	LED LIGHT, burglar alarm	1	alarm indicator LED light fits into dash
18	XHC100010	£7.80	WARNING LAMP	1	seat belt indicator
19	YUC10004	NCA	SWITCH, sunroof	1	fitted to British open classic
	14E3386	NCA	SWITCH PANEL	1	Mkl
	14A7172	£16.00	BEZEL, switch panel	1	Mkl
	ALE2960	£18.00	SWITCH PANEL, grey	1	MkII
	24G6617	£4.56	SWITCH PLINTH, auxiliary	1	(For fog light switch, fitted under lower dash).

Miscellaneous Switches

20	YUE10003	£8.20	SWITCH, door courtesy light	2	
21	GAE191A	£7.45	SWITCH, reverse lights	1	
22	54K1723	£0.84	LOCK NUT, reverse light switch	1	
23	13H3735	£3.58	SWITCH, brake lights	1	mechanical type,
	13H3735X	£11.60	SWITCH, brake lights, uprated	1	fitted on pedal box
24	FNZ208	£0.62	NUT, locking	1	
25	C16062A	£4.27	SWITCH, brake lights	1	hydraulic type, fitted in brake line
26	GTR101	£6.00	SENDER UNIT, water temperature	1	all 998cc models
	GTR185	£9.90	SENDER UNIT, water temperature	1	Cooper 1300
27	GPS133	£3.68	SWITCH, oil pressure	1	

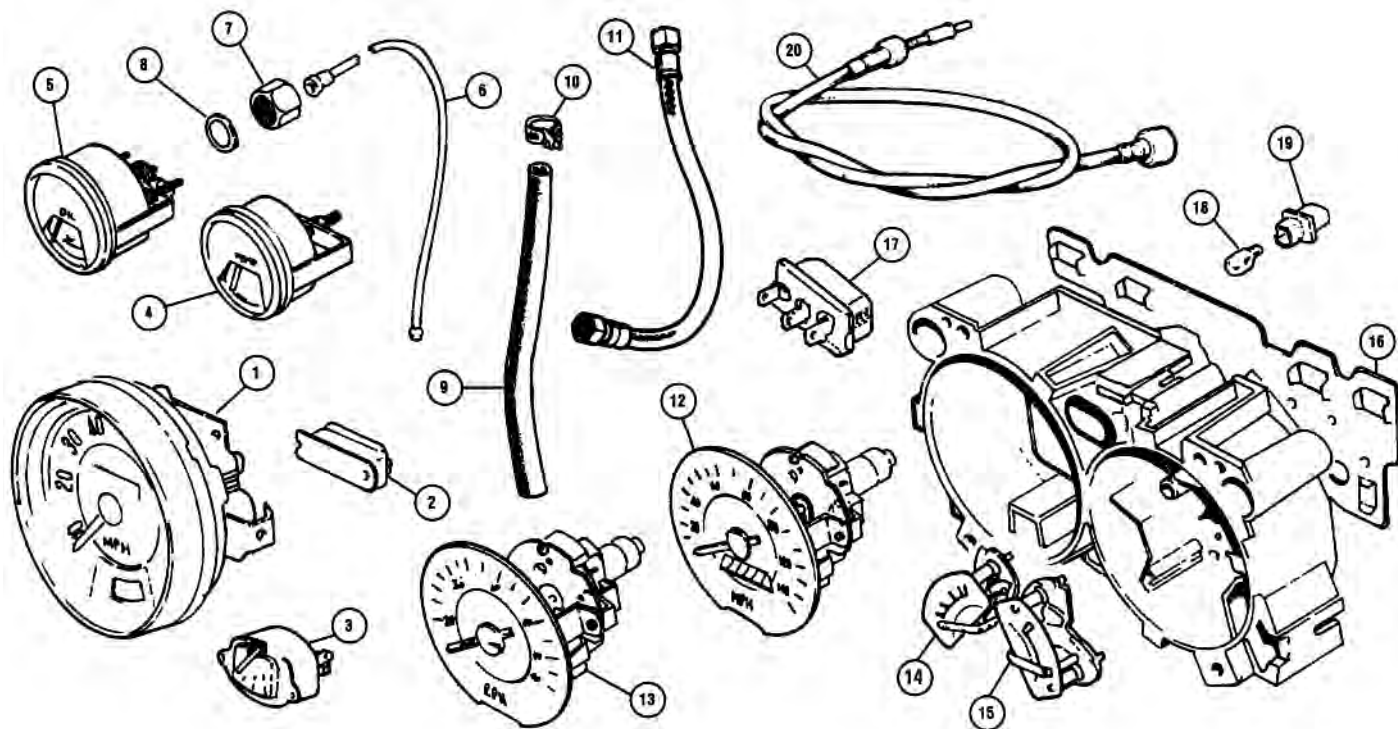

ill. Part Number Price £ea. Description Req. Details

Instruments And Gauges

Centre Binnacle Instruments

1	ADU2341	NCA	SPEEDOMETER, MPH, 90MPH	1	3.4 final drive
	13H4442	£189.00	SPEEDOMETER, MPH, 130MPH	1	Cooper S
	13H4442M	£194.40	SPEEDOMETER, MPH, 130MPH	1	Cooper S, magnolia face
	13H4444	£182.20	SPEEDOMETER, KPH, 200KPH	1	Cooper S
	13H4444M	£265.00	SPEEDOMETER, KPH, 200KPH	1	Cooper S, magnolia face
2	C34770A	£13.00	VOLTAGE STABILISER	1	BR1310/00
3	13H2133E	£49.80	FUEL GAUGE	1	
4	13H4460	£52.50	GAUGE, water temperature	1	
	13H4460W	£46.90	GAUGE, water temperature	1	magnolia face
5	13H4459	£81.00	GAUGE, oil pressure	1	
	13H4459W	£70.50	GAUGE, oil pressure	1	magnolia face
6	21A804	£17.45	OIL PIPE, gauge to hose	1	
7	11B2037	£4.25	NUT	1	
8	2K4936	£0.28	SEALING WASHER	1	
9	ACA5420	£9.30	OIL HOSE	1	
	MT9102	NCA	OIL HOSE	1	braided 4ft long
10	GGT1113X	£1.60	OIL HOSE CLIP	2	
11	LUSIB703	£13.90	HOSE, plastic, oil gauge	1	alternative, with fittings
	CAM4202	£18.20	OIL PIPE, hose to cylinder block	1	
	GLB987	£0.62	BULB, dash illumination	a/r	
	24A2702	£34.30	BINNACLE, 3 clocks	1	centre clocks
	14A9907	£18.00	FINISHER TRIM, centre binnacle	1	
	14A9796	£1.60	CLIP, trim to binnacle	14	
	GAC8460X	£8.30	BINNACLE, crinkle black, single aux	1	for 80mm gauge
	GAC8461X	£10.50	BINNACLE, crinkle black, two aux	1	for 80mm + 52mm gauge
	GAC8468X	£9.80	BINNACLE, crinkle black, single aux	1	for 52mm gauge
	GAC8469X	NCA	BINNACLE, crinkle black, two aux	1	for 52mm gauge
	GAE120	£54.40	GAUGE, dynamo ammeter	1	black half face
	GAE121	£52.70	GAUGE, 52mm, alternator ammeter	1	black half face
	GAE122M	£55.40	GAUGE, 52mm, voltmeter	1	magnolia half face
	GAE122	£50.00	GAUGE, 52mm, voltmeter	1	black half face
	GAE123M	£94.30	GAUGE, 52mm, oil pressure	1	magnolia half face
	GAE123X	£89.50	GAUGE, 52mm, oil pressure	1	black half face
	GAE124M	£55.40	GAUGE, 52mm, electric water temp.	1	magnolia half face
	GAE124X	£53.30	GAUGE, 52mm, electric water temp.	1	black half face
	GAE125X	NCA	GAUGE, 80mm, 0-7000 tachometer	1	black full face
	GAE127X	£162.00	GAUGE, 52mm, w/temp + o/press (Capillary water temp and capillary oil pressure).	1	black two face
	GAE128M	£85.00	GAUGE, 52mm, clock	1	magnolia full face
	GAE128X	£90.00	GAUGE, 52mm, clock	1	black full face

ill. Part Number Price £ea. Description Req. Details

GAE129M	£73.40	GAUGE, 52mm, oil temperature	1	magnolia half face
GAE130A	£165.80	GAUGE, 80mm, 0-10000 tachometer	1	black full face
GAE130M	£159.30	GAUGE, 80mm, 0-8000 tachometer	1	magnolia full face

All Saloons After 1980 (Smiths Only)

12	ADU2281	£94.45	SPEEDOMETER, MPH	1	HL models
	ADU2283	NCA	SPEEDOMETER, KPH	1	To VIN122248
	ADU6142	NCA	SPEEDOMETER, MPH (From VIN122249 To VIN290002).	1	HLE, Mayfair & Ritz
	BAU5340	NCA	SPEEDOMETER, KPH (From VIN122249 To VIN290002).	1	HLE & Mayfair only
	BAU5340	NCA	SPEEDOMETER, KPH (From VIN277263 To VIN290002).	1	Ritz only
	BAU5402	NCA	SPEEDOMETER, MPH	1	From VIN290003
	BAU5403	NCA	SPEEDOMETER, KPH	1	
13	ADU1197E	NCA	TACHOMETER	1	To VIN290002
	BAU5404	NCA	TACHOMETER	1	From VIN290003
14	13H5894	NCA	FUEL GAUGE	1	To VIN122248
	ADU6455	NCA	FUEL GAUGE	1	From VIN122249 To VIN290002
	BAU5405	NCA	FUEL GAUGE	1	From VIN290003
15	13H5893	NCA	TEMPERATURE GAUGE	1	To VIN122248
	ADU6456	NCA	TEMPERATURE GAUGE	1	From VIN122249 To VIN290002
	BAU5406	NCA	TEMPERATURE GAUGE	1	From VIN290003
16	37H4881	NCA	PRINTED CIRCUIT BOARD	1	2 clock pod
	BAU1930	NCA	PRINTED CIRCUIT BOARD	1	3 clock pod
	CDU3247	£75.00	PRINTED CIRCUIT BOARD	1	3 clock pod 1989-96
	YAH100750	NCA	PRINTED CIRCUIT BOARD	1	3 clock pod 1996-On
17	BMK1539A	£24.90	VOLTAGE STABILISER	1	
18	GLB297	£1.60	BULB, dash illumination	a/r	
19	13H5270	NCA	BULB HOLDER	a/r	
20	GSD152	£12.80	DRIVE CABLE, speedometer	1	centre binnacle
	GSD102	£9.00	DRIVE CABLE, speedometer	1	To VIN122248
	GSD415	£13.20	DRIVE CABLE, speedometer	1	From VIN122249
	GSD402	£12.60	DRIVE CABLE, speedometer	1	LHD all models
	GSD487	£11.65	DRIVE CABLE, speedometer	1	1989-On
	MT9501B	£25.90	GAUGE FACE KIT, blue	1	Nippon Seiko 89-On
	MT9501G	£25.90	GAUGE FACE KIT, green	1	Nippon Seiko 89-On
	MT9501M	£26.50	GAUGE FACE KIT, magnolia	1	Nippon Seiko 89-On
	MT9501R	NCA	GAUGE FACE KIT, red	1	Nippon Seiko 89-On
	MT9501S	£25.90	GAUGE FACE KIT, silver	1	Nippon Seiko 89-On
	MT9501W	£25.90	GAUGE FACE KIT, white	1	Nippon Seiko 89-On
	MT9501Y	NCA	GAUGE FACE KIT, yellow	1	Nippon Seiko 89-On
	GAC8453X	£450.00	CENTRE BINNACLE KIT	1	Accessories section

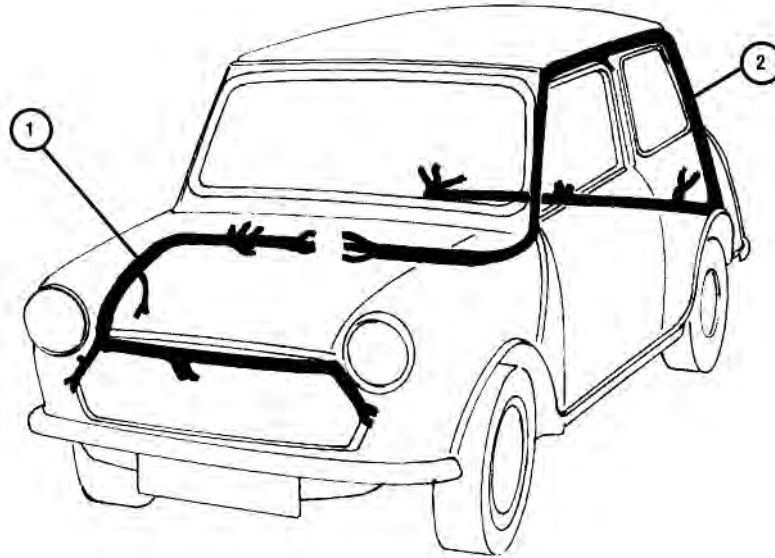

iii. Part Number Price £ea. Description Req. Details

Wiring Looms

Note: Although most of the Mini wiring looms are shown as NCA most are still available as a special order item. Please contact your local branch to discuss your requirements.

Front Wiring Looms

Part Number	Price £ea.	Description	Req.	Details
5L503	£227.10	MAIN LOOM (850 Super Deluxe, Cooper Mkl RHD).	1	1963-67
5L518	£227.10	MAIN LOOM (Cooper Mkl complete)	1	1965-67
5L1332	NCA	MAIN & TAIL LOOM (850 Coil on bell housing, No temperature gauge).	1	1959-60
5L518LHD	£231.60	MAIN LOOM (1275 with oil filter light).	1	Mkl COOPER LHD
5L1331	£213.70	MAIN & DASH LOOM (Comm no. N20S165797A To N20S 320000A (alternator fitted)).	1	1972-75
HAM1199	£208.10	MAIN & DASH LOOM (Comm no. N20S320001A To N20S 358125. 2 column stalk switches and mechanical brake switch).	1	1976-77
HAM1487	£216.40	MAIN & DASH LOOM (Comm no. N20S358126 To N20S 363841. Reverse lamps 4 Fuse box).	1	1978
HAM2174	£216.40	MAIN & DASH LOOM (Comm no. N20S363842 To N20S 122248. Fog lamps and offset instrument binnacle).	1	1979-81
HAM2859	NCA	MAIN & DASH LOOM (VIN122249 - 179627. No reverse lamps).	1	City E model UK only
HAM2921	NCA	MAIN & DASH LOOM (VIN 122249 - 179658).	1	City E model not UK
HAM3683	NCA	MAIN & DASH LOOM (VIN179628 On).	1	City E model UK only
HAM3682	NCA	MAIN & DASH LOOM (VIN 179659 On).	1	City E model not UK
HAM2315	NCA	MAIN & DASH LOOM (Up To VIN 107477).	1	HL model
HAM2705	NCA	MAIN & DASH LOOM (VIN 107478 - 122248. Washer pump in bottle).	1	HL model
HAM2861	NCA	MAIN & DASH LOOM (VIN 122249 - 179630. Tachometer included).	1	HLE, Mayfair, Sprite
HAM3684	NCA	MAIN & DASH LOOM (VIN 179631 onwards).	1	HLE, Mayfair, Sprite
HAM4625	NCA	MAIN & DASH LOOM (VIN 253000 To VIN 345417. Pre-engaged starter & repeater lamps).	1	All LHD Models
HAM4626	£240.40	MAIN & DASH LOOM (VIN 253000 To VIN 328623).	1	All RHD models
HAM4625	NCA	MAIN & DASH LOOM (VIN 345418 - 396448. Dim & dip head lamps, large indicator lamps).	1	All LHD models
HAM4626	£240.40	MAIN & DASH LOOM (VIN 328624 To 396448. Dim & dip head lamps).	1	All RHD models

iii. Part Number Price £ea. Description Req. Details

YMC10201	NCA	MAIN & DASH LOOM (From VIN 396449 To VIN 426487 (approximately)).	1	All RHD models
YMC10202	NCA	MAIN & DASH LOOM (From VIN 396449 To VIN 426487 (approximately)).	1	All LHD models
YMC10654	NCA	MAIN & DASH LOOM (VIN 426488 (approximately) To VIN 504653).	1	All RHD models
YMC10655	NCA	MAIN & DASH LOOM (VIN 426488 (approx.) to VIN 504653).	1	All LHD models
YMC11768	NCA	MAIN & DASH LOOM (VIN 504654 On with dim/dip head lamps).	1	All manual cars
YMC11769	NCA	MAIN & DASH LOOM (VIN 504654 On without dim/dip head lamps).	1	All manual cars
YMC11428	£253.80	MAIN & DASH LOOM	1	RHD Cooper 1300cc
YMC11388	NCA	MAIN & DASH LOOM	1	RHD Cooper SE
YMC11389	NCA	MAIN & DASH LOOM	1	LHD Cooper 1300cc & SE

Rear Wiring Looms

Part Number	Price £ea.	Description	Req.	Details
5L875	£34.70	BODY LOOM (Comm no. N20S165797A To N20S 320000A. Use with 5L1331).	1	1972-75
HAM1301	NCA	BODY LOOM (Comm no. N20S320001A To N20S 358125. Use with HAM1199).	1	1976-77
HAM1286	£53.50	BODY LOOM (Comm no. N20S35126A To N20S 435211).	1	
HAM1924	NCA	BODY LOOM (Comm no. N20S358126 (VIN unknown), XL25IN100001 To N20S 675453).	1	
HAM2920	NCA	BODY LOOM (City Export To VIN 228613, City Europe & Sprite RHD VIN 122249 On).	1	
HAM2846	NCA	BODY LOOM (City Export VIN 228614 On, 1000cc & HL models XL25IN675454 On, City Europe & Sprite RHD VIN 140358 - 252999, Mayfair UK VIN 100720 - 147143).	1	
HAM3065	£56.10	BODY LOOM (VIN 147144 - 252999).	1	Mayfair UK
HAM3835	£53.50	BODY LOOM (VIN 25300 - 441904).	1	City E UK & Ritz LHD
HAM3835	£53.50	BODY LOOM (VIN 441905).	1	Mayfair & Ritz RHD
YMD10258	NCA	BODY LOOM (VIN 441905).	1	All RHD models
HAM3836	NCA	BODY LOOM (To VIN 442929).	1	All LHD models
YMD10259	NCA	BODY LOOM (VIN 442930 On).	1	
YMD10502	NCA	BODY LOOM (To VIN057167).	1	Sprite, Mayfair, Cooper
YMD10744	NCA	BODY LOOM (To VIN057168).	1	Sprite, Mayfair, Cooper

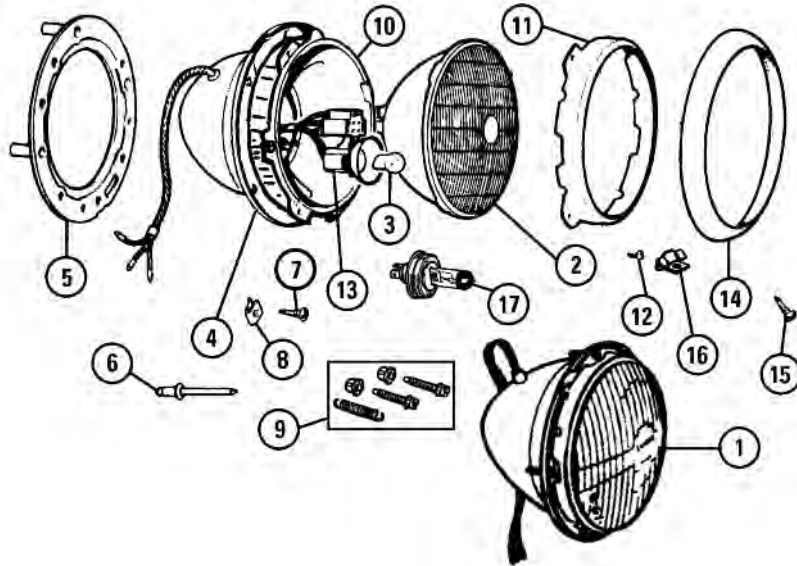

ill.	Part Number	Price £ea.	Description	Req.	Details
Headlamps & Fittings					
1	13H7922	NCA	HEADLAMP ASSEMBLY, sealed beam	2	RHD, Lucas
	BHM7198	£49.00	HEADLAMP ASSEMBLY, sealed beam	2	RHD, Wipac
	XBC103220	£134.60	HEADLAMP ASSEMBLY, levelling type	2	LHD (Includes: headlamp, level motor & wire harness).
	XBC105220	£74.50	HEADLAMP ASSEMBLY, levelling type	2	RHD, no chrome rim
	XBC105230	£80.70	HEADLAMP ASSEMBLY, levelling type	2	LHD (Includes: headlamp, level motor & wiring harness).
2	13H3471A	£15.20	LAMP UNIT, sealed beam	2	RHD
	27H5981A	£22.20	LAMP UNIT, sealed beam	2	LHD
	BAU1177A	£49.09	LAMP UNIT, bulb type	2	LHD
	GLB410	£2.90	BULB, headlamp, white	2	France only
	GLB472	£5.12	BULB, headlamp, halogen H4, 60/55W	2	standard bulb
	GLB484	£6.20	BULB, headlamp, halogen H4, 100/90W	2	not road legal
	GLB472X	£10.40	BULB, headlamp, Xenon H4, 60/55W	2	
	GLB472BLU	£10.40	BULB, headlamp, Xenon H4, 60/55W	2	blue tint
3	GLB233	£0.79	BULB, side lamp, bayonet	2	
	GLB501	£0.73	BULB, side lamp, capless, push fit	2	
4	SML3	£15.20	BUCKET, headlamp, metal	2	
	SML3P	£16.60	BUCKET, headlamp, plastic	2	
Note: SML3P does not require the inner mounting ring or outer lamp retainer. It comes complete with adjusters, rubber seal and body fixings. Still requires 500929 chrome rim.					
5	009403	£4.82	SEAL, bucket to body	2	
6	569313	£0.60	RIVET, lamp to wing	8	
7	GHF426	£0.19	SCREW	8	alternatives
8	GHF713	£0.37	SPIRE CLIP	8	
9	BHM7058	£5.00	ADJUSTER KIT	2	
10	27H6481	£23.45	MOUNTING RING, inner, plastic	2	
	SML4	£9.00	MOUNTING RING, inner, metal	2	
11	515218A	£5.50	RIM, lamp unit retaining	2	
12	AB606021	£0.32	SCREW, rim retaining	6	
13	BAU2111	£10.40	HARNES, headlamp	2	saloon with side lamp holder
	BAU2110	£7.64	HARNES, headlamp	2	clubman without side lamp
14	500929	£16.00	RIM, chrome	2	
	DHF100060	£41.40	RIM, chrome	2	levelling headlamps only
15	RTC465	£0.54	SCREW, headlamp rim	2	
16	37H7421A	£1.80	SPIRE CLIP, headlamp rim	2	

Halogen Conversion Kits

Note: Halogen headlamp conversion kits. Kits include 2 lamp units, bulbs and side light fittings. Also available are kits for Clubman models without side lamp fitted in the headlamp.

GAC4023	£50.00	HEADLAMP KIT, Lucas, halogen H4	1	RHD
GAC4023Z	£51.25	HEADLAMP KIT, Wipac, halogen H4	1	RHD
GAC4023X	£50.00	HEADLAMP KIT, Wipac, crystal H4	1	RHD
GAC4022	£43.45	HEADLAMP KIT, Wipac, halogen H4	1	RHD without side lamp
GAC4022X	£58.90	CRYSTAL LAMP KIT	1	RHD without side lamp
LULUB802	£99.90	HEADLAMP KIT, Lucas, halogen H4	1	LHD

ill.	Part Number	Price £ea.	Description	Req.	Details
	WPS4699	£61.60	HEADLAMP KIT, Wipac, halogen H4	1	LHD
	£61.60	£61.60	HID CONVERSION KIT, H4 (Use with H4 headlamp conversion).	1	upgrade H4 halogen headlamps

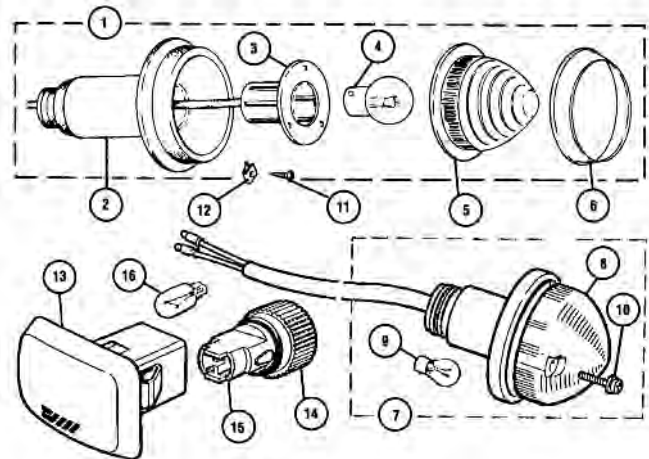

ill.	Part Number	Price £ea.	Description	Req.	Details
Front Indicator & Side Repeater Lamps					
1	CHM13	£7.80	LAMP, indicator, plastic amber lens	2	To 1986
	2A9013	£15.60	LAMP, indicator, glass amber lens	2	alternatives
2	508162	£2.42	SEAL, rubber	2	
3	37H5528	£6.14	HOLDER, bulb	2	
4	GLB382	£0.73	BULB, single filament	2	
5	37H5520	£6.60	LENS, amber glass	2	
	37H5520Z	£4.82	LENS, amber glass	2	aftermarket
	37H8130	£2.84	LENS, amber plastic	2	alternative
6	7H5182	£2.23	RIM, lens retaining	2	
7	AFU3389	£7.30	LAMP, indicator, screw on lens	2	
8	CDU3374	£3.38	LENS, amber, screw fixing	2	1987-On
	CDU3374W	£2.53	LENS, white, screw fixing	2	
9	GLB382	£0.73	BULB, single filament	2	
	GLB343	£1.96	BULB, amber, single filament	2	
(Required when fitting clear indicator lens).					
10	AB60601SS	£0.48	SCREW, lens retaining	2	
11	GHF421	£0.17	SCREW, lamp to body	6	
12	AK606021	£0.48	SPIRE CLIP, on body	6	
	AAU3296A	NCA	REPEATER LAMP	2	
13	AHU2592	£4.20	REPEATER LENS	2	
	AHU2592W	£5.35	REPEATER LENS, white	2	
14	DCP8004	£9.20	HOLDER, bulb	2	1986-On
15	AFU3112	£1.04	SEAL, bulb holder	2	
16	GLB501	£0.73	BULB	2	
	GLB501X	£1.36	BULB, amber	2	
(Required when fitting clear indicator lens).					
NI	AFU3358	£32.40	LOOM, indicator side repeater	2	

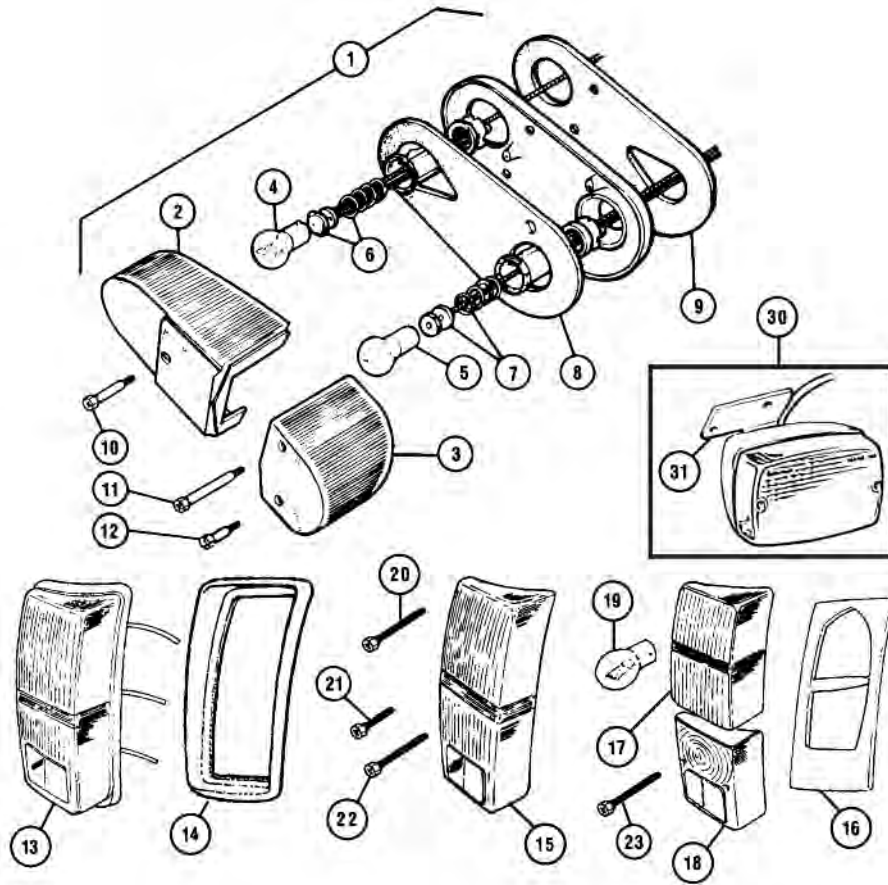

ill. Part Number Price £ea. Description Req. Details

Rear Lamp Assemblies

Mkl Models

1	BHA4228	£53.90	LAMP ASSEMBLY, rear, RH	1	
	BHA4229	£53.90	LAMP ASSEMBLY, rear, LH	1	
2	47H5363	£9.10	LENS stop/tail, RH	1	
	47H5358	£9.10	LENS stop/tail, LH	1	
3	47H5362	£9.00	LENS, indicator, RH	1	} amber
	47H5355	£9.00	LENS, indicator, LH	1	
4	GLB380	£0.62	BULB, stop/tail, dual filament	2	
5	GLB382	£0.73	BULB, flasher, single filament	2	
6	37H5459	£3.10	TERMINAL KIT, bulb socket	2	twin contact
7	37H5452	£2.80	TERMINAL KIT, bulb socket	2	single contact
8	47H5360	£2.96	GASKET, lens to base	2	
9	57H5399	£3.30	GASKET, lamp to body	2	
	47H5356K	£8.60	SCREW SET, lens retaining	2	
10	47H5359	£1.36	SCREW, stop/rear light lens	2	
11	47H5356	£1.70	SCREW, flasher lens, long	2	
12	47H5357	£1.30	SCREW, flasher lens, short	2	

Mkll on Models

There were several manufacturers of rear lamps during Mini production; Altissimo and Lucas/Carello. The Lucas/Carello type can be identified by the 'posts' which accept the lens retaining screws. Lucas/Carello are the most common type and are the type that are currently available.

13	13H6479	£63.35	LAMP ASSEMBLY, RH	1	without
	13H6480	£63.35	LAMP ASSEMBLY, LH	1	reverse light
	XFB10082	£84.00	LAMP ASSEMBLY, RH	1	
	XFB10082Z	£76.50	LAMP ASSEMBLY, RH, alternative	1	with reverse light
	XFB10083	£84.00	LAMP ASSEMBLY, LH	1	and 2 piece lens
	XFB10083Z	£76.50	LAMP ASSEMBLY, LH, alternative	1	
14	37H2690	£8.15	SEAL, lamp to body, RH	1	for lamps without
	37H2689	£8.15	SEAL, lamp to body, LH	1	reverse light
	37H2692	£10.90	SEAL, lamp to body, RH	1	for Lucas type
	37H2691	£10.90	SEAL, lamp to body, LH	1	lamps
15	37H4838	£25.80	LENS, stop/tail & indicator, RH	1	for lamps without
	37H4837	£25.80	LENS, stop/tail & indicator, LH	1	reverse light
16	37H6778	£1.66	SEAL, lens to lamp body	2	for lamps without
				2	reverse light
	XFH100460	£3.40	SEAL, lens to lamp body	2	for lamps with
				2	reverse light

ill. Part Number Price £ea. Description Req. Details

17	XFJ10026	£19.40	LENS, stop/tail & indicator, RH	1	} for Lucas type lamps
	XFJ10026Z	£8.65	LENS, stop/tail & indicator, RH, altern.	1	
	XFJ10027	£19.40	LENS, stop/tail & indicator, LH	1	
	XFJ10027Z	£8.65	LENS, stop/tail & indicator, LH, altern.	1	
	AAU4946	£43.45	LENS SET, RH (Includes: stop/tail & indicator lens, reverse lens and seal & screws).	1	} for Altissimo type lamps
	AAU4947	NCA	LENS SET, LH (Includes: stop/tail & indicator lens, reverse lens and seal & screws)	1	
	GAC4617	£16.30	CLEAR LENS SET, stop/tail & indicator (Includes: clear stop/tail & indicator lenses only. Bulbs and seals sold separately. Requires bulbs: 2 x GLB343 and 2 x GLB380R).	1	} use with Lucas type lamps only
18	XFJ10028	£14.40	LENS, reverse lamp, RH	1	
	XFJ10028Z	£8.15	LENS, reverse lamp, RH, alternative	1	
	XFJ10029	£18.00	LENS, reverse lamp, LH	1	
	XFJ10029Z	£8.15	LENS, reverse lamp, LH, alternative	1	
19	GLB382	£0.73	BULB, single filament (Clear bulb for standard coloured lenses).	a/r	indicator/reverse
	GLB343	£1.96	BULB, single filament, indicator (Amber tinted bulb for clear indicator lenses only).	a/r	
	GLB380	£0.62	BULB, twin filament, stop/tail (Clear bulb for standard coloured lenses).	a/r	
	GLB380R	£2.23	BULB, twin filament, stop/tail (Red tinted bulb for clear indicator lenses only).	a/r	
20	PMP214	£0.60	SCREW, top	2	without
21	PMP214	£0.60	SCREW, bottom, short	2	reverse lamp
22	518868	£0.73	SCREW, bottom, long	2	
23	XYPP100310	NCA	SCREW, lens retaining	6	with reverse lamp

Rear Fog Lamps

30	XFE10006	£25.30	FOG LAMP, rear, without bracket	1	RHD
	XFE10007	£30.00	FOG LAMP, rear, with bracket	1	LHD
31	XFU10002	NCA	BRACKET, fog lamp RHD	1	RHD
	XFU10003	NCA	BRACKET, fog lamp LHD	1	LHD
	GAC9400X	£28.30	BRACKET, fog lamp (Relocates fog lamp when fitting overriders).	1	RHD

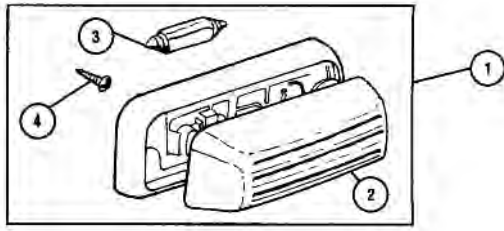

ill. Part Number Price £ea. Description Req. Details

Miscellaneous Lamps

Interior Lamps

1	13H8919	NCA	INTERIOR LAMP, clear cover	1	To 1976
	EAM1650	£9.10	INTERIOR LAMP, white cover	1	1976-85
	AFU3003	NCA	INTERIOR LAMP, in headlining	1	1985-On
2	37H5923	NCA	LENS, for lamp 13H8919	1	
	24G3389	£6.80	LENS, for lamp EAM1650	1	
3	GLB239	£0.79	BULB, festoon	1	
4	AB606051	£0.37	SCREW, lamp retaining	2	

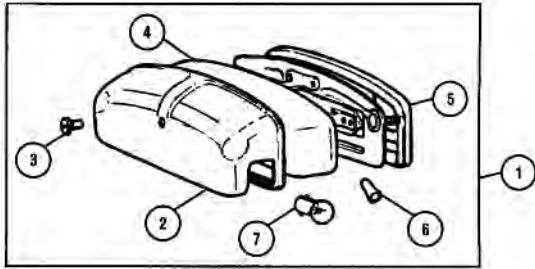

ill. Part Number Price £ea. Description Req. Details

Mkl Number Plate Lamp

1	127916BLK	£30.30	NUMBER PLATE LAMP, black OE	1	Mkl
	127916	£24.40	NUMBER PLATE LAMP, chrome	1	} alternative
	127916Z	£14.40	NUMBER PLATE LAMP, plastic	1	
2	502264	£11.35	COVER CHROME	1	
3	17H5385	£2.05	SCREW, lens cover to back plate	1	
4	601721A	£5.00	LENS, clear glass	1	
5	57H5368	£3.58	GASKET	1	
6	27H6713	£0.89	CONNECTOR, bullet terminal	2	
7	GLB989	£0.89	BULB	2	

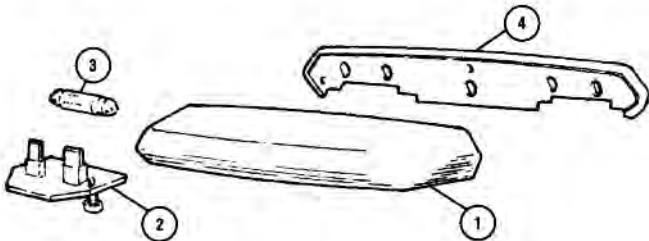

ill. Part Number Price £ea. Description Req. Details

MklIII Number Plate Lamp

1	13H6900	£26.50	BODY, number plate lamp	1	MklIII, unpainted
	GAC4614	£16.80	BODY, number plate lamp	1	} MklIII, chromed metal body
2	PRC1230A	£7.30	LENS, number plate lamp	2	
3	GLB239	£0.79	BULB, festoon	2	
4	13H6010	£4.30	GASKET, lamp body to boot lid	1	



British Motor Heritage Certificate of Authenticity

When you purchase a BMH bodyshell from Moss Europe, you will receive a Certificate of Authenticity from British Motor Heritage. Confirming: BMH manufacture, date of purchase, body style and number.

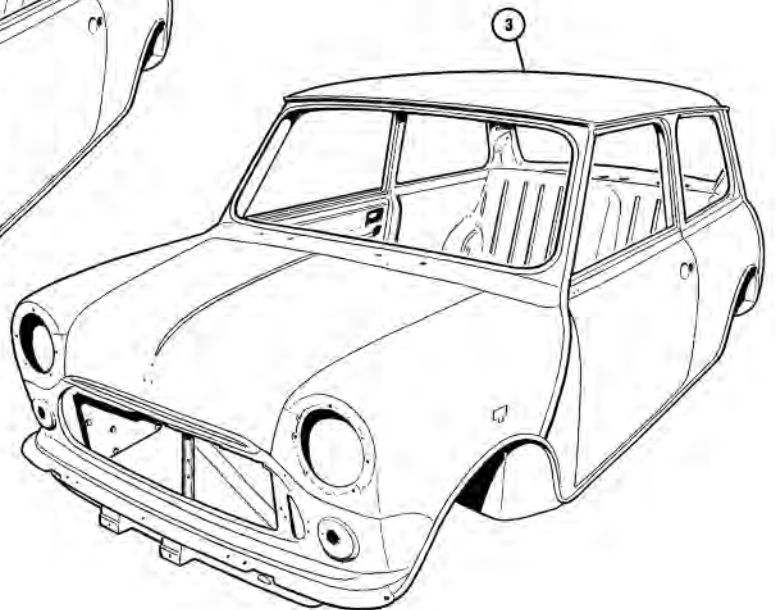
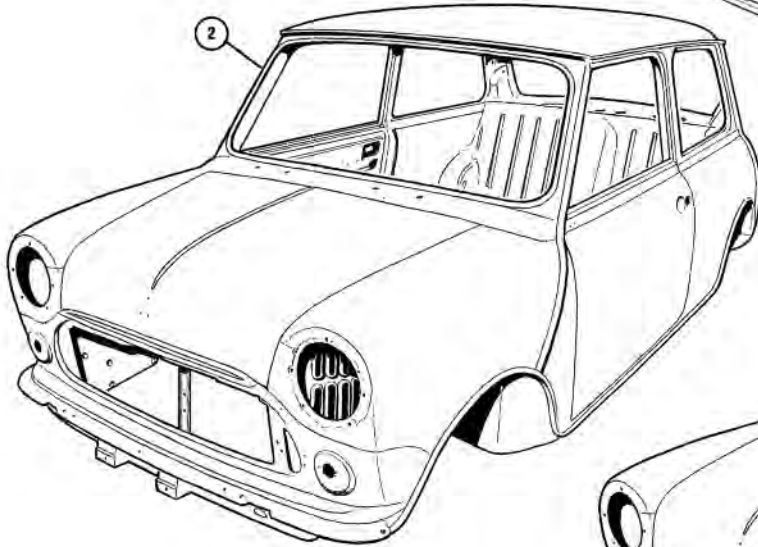
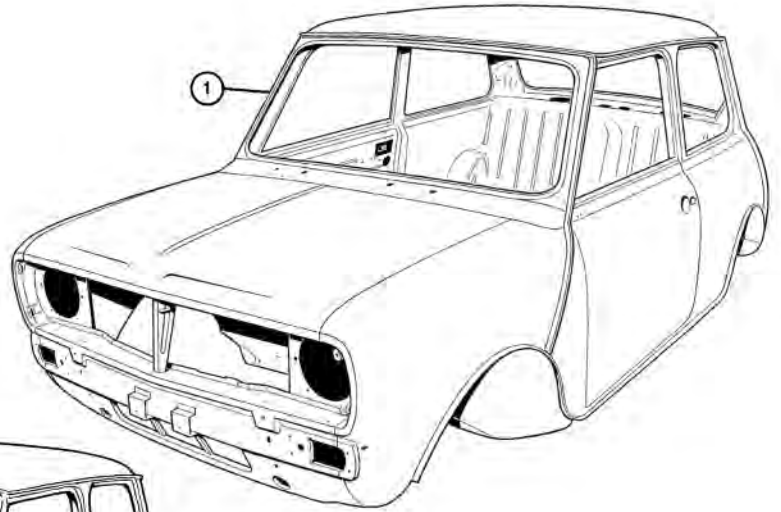

ill. Part Number Price £ea. Description Req. Details

British Motor Heritage Bodyshells

If your car needs major bodywork repairs a new bodyshell may be the best option. The cost is less than you think, by the time you add in the labour cost of fitting body parts it may well be the cheapest option.

British Motor Heritage bodyshells are built using the original assembly jigs. Long life is ensured by the use of zinc coated steel in rust prone areas, the shells are finished in motor industry standard black electrocoat. The shells are completely immersed in an electrically charged tank of anodic etch primer. This ensures the best possible coverage and paint ingress into all area of the body. The bodyshells listed below come with doors, bonnet and bootlid, they are also available without these bolt-ons please contact your branch for details.

Bodyshell policy

1. Bodyshells are purchased with a 30% deposit as a special order item and customers must pay all delivery charges.
2. When bodyshells are received, the customer will be notified and delivery will take place within 14-21 days.
3. There will be storage charge (call) per day drawn from the deposit beginning on the 22nd day following notification if the customer is unable to take delivery.
4. If delivery is not taken within 30 days, the remaining deposit money will be returned to the customer and the order cancelled.

Clubman bodyshell

The Heritage Clubman bodyshell is a direct replacement for 1976 on Clubman models with rubber mounted subframes. It can be used for earlier cars with some modifications, 1972-76 cars will need the subframes replacing with the rubber mounted versions,

ill. Part Number Price £ea. Description Req. Details

1969-72 models had a different gear shift mechanism that will need some modifications to the bodyshell.

1	CZH594	£8,050.00	BODYSHELL, Clubman	1
---	--------	-----------	--------------------	---

MkIV bodyshell

The MkIV bodyshell is suitable for all models 1976 to 1989 with rod change and rubber mounted subframes. As with the Clubman shell this can be fitted to 1972-76 models by changing to rubber mounted subframes. For earlier models more modifications will be necessary.

The bodyshell comes with front wings without repeater holes, roof without aerial holes, slatted inner wing for side mounted radiators and the MkIV grille panel. The dashboard bulkhead panel includes the large 'rotodip' aperture making access to the centre binacle easier. Rear seatbelt mountings are fitted and front seatbelt mountings are in the pre-1977 locations. Doors supplied with side impact bars fitted.

2	BMP343	£7,750.00	BODYSHELL, MkIV	1
---	--------	-----------	-----------------	---

The MkIV throttle body injection (TBI) shell is most suitable for MkIV 1990-1996 models. This bodyshell has the large round hole in the inner wing for the cooling fan.

2	AAA36002	£7,750.00	£7750.00	1
---	----------	-----------	----------	---

MkV bodyshell

These bodyshells are for cars produced from 1997 onwards, available to either standard or Sports Pack specification. Latest specification brackets for airbag sensor, alarm and boot mounted washer bottle are not included. Compatible with front mounted radiators.

3	AAA360200	£7,750.00	BODYSHELL, MkV, standard	1
	AAA360210	£7,750.00	BODYSHELL, MkV, Sports-Pack	1

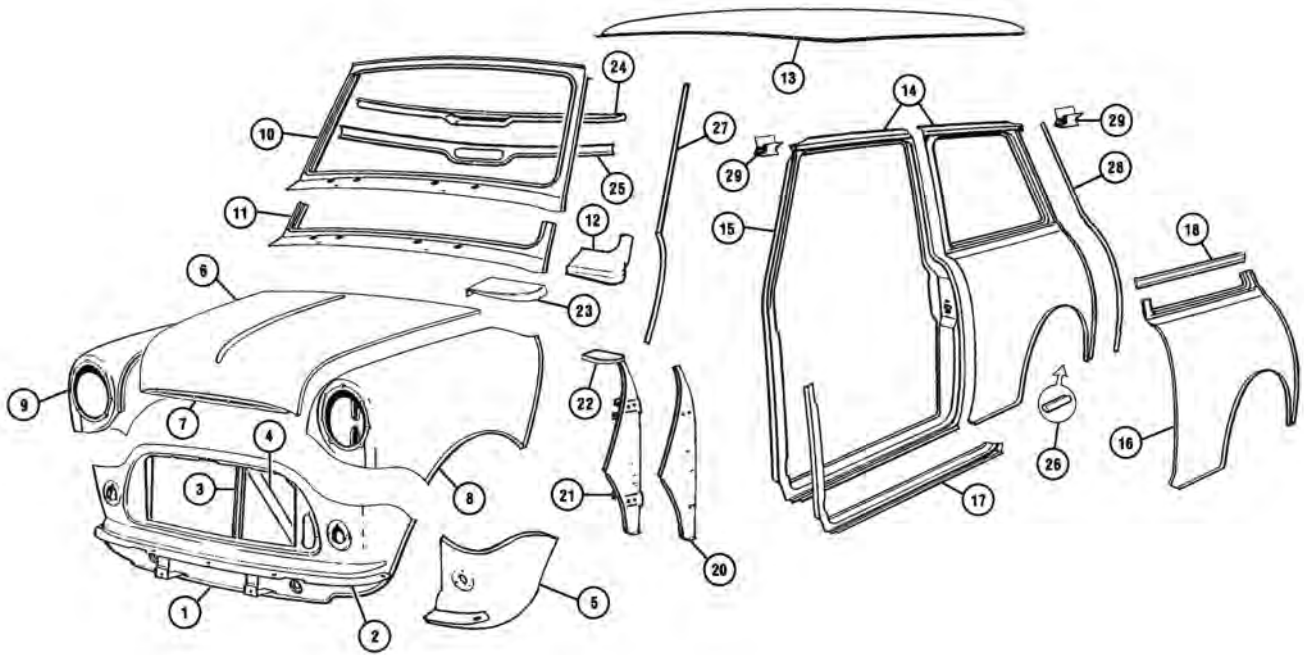

ill.	Part Number	Price £ea.	Description	Req.	Details
Front & Side Body Panels					
Saloon Models					
1	14A8308	£195.00	FRONT PANEL	1	1964-75
	MBP9026	£138.50	FRONT PANEL	1	to 1976
	ALA8619	£194.00	FRONT PANEL	1	1976-89
	ALA8619Z	£98.80	FRONT PANEL, aftermarket	1	1976-89
	ASJ36002	£194.00	FRONT PANEL	1	1990-96
	ASJ360070	£194.00	FRONT PANEL	1	1996-On
2	BMP103	£17.00	BUMPER MOUNTING RAIL	1	all models
3	ALA4583	£9.70	SUPPORT, slam panel, vertical	1	to 1996
4	24A1918	£12.20	SUPPORT, slam panel, diagonal	1	with oil cooler
5	MBP9001	£77.40	REPAIR PANEL, lower front panel, RH	1	aftermarket
	MBP9002	£77.40	REPAIR PANEL, lower front panel, LH	1	aftermarket
6	24A1182	£182.80	BONNET	1	1959-67
	ALA8430	£183.00	BONNET	1	van & pick up 1972-83
	ALA7455	£183.00	BONNET	1	1967-69
	CZH455	£182.00	BONNET	1	1970-96
	CZH455Z	£150.00	BONNET, aftermarket	1	1970-96
	BKA360070	£183.00	BONNET	1	1997-On
	BKA360110	£182.00	BONNET	1	1997
7	ALA6664	£18.30	BRACKET, bonnet moulding lip	1	1967-On
8	14A7240	£104.00	WING, RH	1	to 1986
	14A7241	£104.00	WING, LH	1	
	14A6476Z	£78.40	WING, RH, aftermarket	1	no side repeater
	14A6477Z	£78.40	WING, LH, aftermarket	1	hole, to 1986
	BMP454	£105.00	WING, RH	1	with side repeater
	BMP454Z	£80.20	WING, RH, aftermarket	1	hole, 1986-On
	BMP455	£105.00	WING, LH	1	with side repeater &
	BMP455Z	£71.70	WING, LH, aftermarket	1	aerial hole, 1986-On
	ASB360010	£105.00	WING, LH	1	with side repeater hole, no aerial hole
9	14A6693	£12.20	HEADLAMP RING	2	1959-86
10	CZH3140	£216.00	WINDSCREEN FRAME	1	1970-On
11	HMP441001	£138.50	REPAIR PANEL, scuttle, full	1	windscreen lower
	MBP9000	£88.40	REPAIR PANEL, scuttle, full, aftermarket	1	panel
12	MBP9005	£26.00	REPAIR PANEL, RH, aftermarket	1	windscreen lower
	MBP9006	£26.00	REPAIR PANEL, LH, aftermarket	1	corner
13	14A5503	£407.00	ROOF PANEL, no aerial	1	1969-96
14	CZH430	£366.00	SIDE PANEL, RH, complete	1	1970-On
	CZH431	£366.00	SIDE PANEL, LH, complete	1	

ill.	Part Number	Price £ea.	Description	Req.	Details
15	CZH122	£122.00	DOOR SURROUND, RH	1	1970-On
	CZH123	£122.00	DOOR SURROUND, LH	1	
16	HMP441014	£123.00	QUARTER PANEL, rear, RH	1	
	MBP9019	£97.00	QUARTER PANEL, rear, RH, aftermarket	1	lower section below
	HMP441015	£123.00	QUARTER PANEL, rear, LH	1	window line, 1970-On
	MBP9020	£97.00	QUARTER PANEL, rear, LH, aftermarket	1	
17	HMP441012	£87.50	DOOR STEP REPAIR, RH	1	1970-On
	HMP441013	£87.50	DOOR STEP REPAIR, LH	1	
18	CZH426	£50.00	WAIST RAIL ASSY, RH	1	1970-On
	CZH427	£50.00	WAIST RAIL ASSY, LH	1	
20	14A6901	£37.80	A PANEL, outer, RH	1	
	14A6901Z	£16.40	A PANEL, outer, RH, aftermarket	1	1959-69
	14A6902	£37.80	A PANEL, outer, LH	1	
	14A6902Z	£16.00	A PANEL, outer, LH, aftermarket	1	
	ALA5660	£23.00	A PANEL, outer, RH	1	
	ALA5660Z	£16.60	A PANEL, outer, RH, aftermarket	1	1970-On
	ALA5661	£23.00	A PANEL, outer, LH	1	
	ALA5661Z	£16.60	A PANEL, outer, LH, aftermarket	1	
21	14A8346	£72.00	A PANEL, inner, RH	1	1959-69
	14A8346Z	£38.80	A PANEL, inner, RH, aftermarket	1	
	14A8347	£72.00	A PANEL, inner, LH	1	1959-69
	14A8347Z	£42.50	A PANEL, inner, LH, aftermarket	1	
22	14A8348	£14.00	GUSSET, A post, RH	1	top of A post
	14A8349	£14.00	GUSSET, A post, LH	1	1959-69
23	MBP9007	£9.10	REPAIR PANEL, closing, RH, aftermarket	1	fitch to scuttle
	MBP9008	£9.10	REPAIR PANEL, closing, LH, aftermarket	1	1970-On
24	14A6675	£37.00	DASH RAIL, top	1	all models
25	BMP201	£51.00	DASH RAIL, bottom	1	1970-On
26	14A6782	£3.20	SEAM COVER LOWER, rear	2	all models
27	BMP127	£21.00	MOULDING, front seam	2	
	BMP127Z	£12.70	MOULDING, front seam, aftermarket	2	
28	BMP124	£18.60	MOULDING, rear seam, RH	1	
	BMP124Z	£15.00	MOULDING, rear seam, RH, aftermarket	1	
	BMP125	£18.60	MOULDING, rear seam, LH	1	
	BMP125Z	£13.70	MOULDING, rear seam, LH, aftermarket	1	
	8B12400	£31.00	MOULDINGS, front, pair	1	stainless steel
	8B12401	£29.20	MOULDINGS, rear, pair	1	
29	GHF1560	£0.32	CLIP	a/r	for body seam moulding
	BMP128MS	£0.32	CLIP, stainless steel	a/r	for body seam moulding

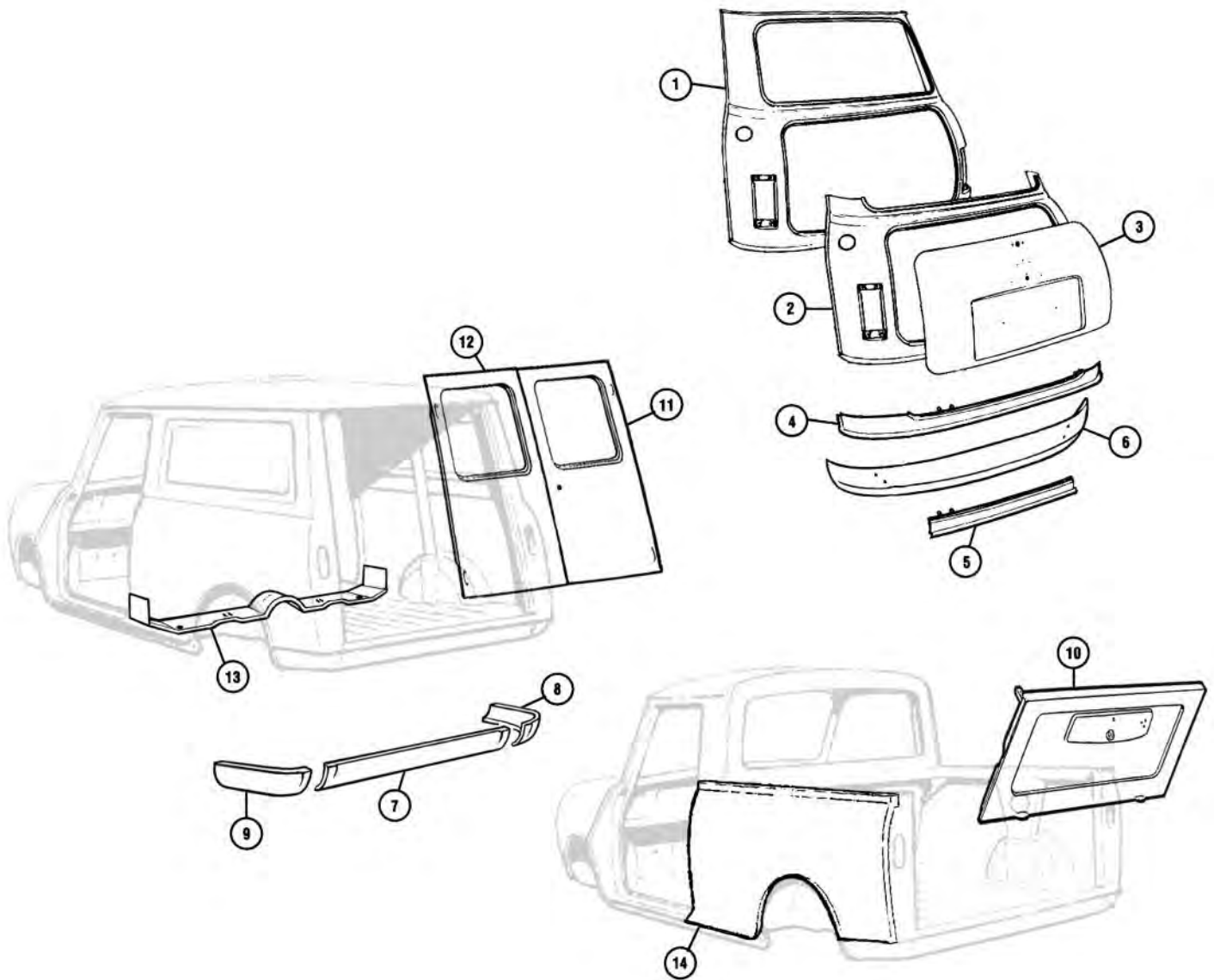

iii. Part Number Price £ea. Description Req. Details

Rear Body Panels

Saloon, Van & Pickup Models

1	HMP441046	£337.80	REAR PANEL, complete	1	Mkl rear lamps
	HMP441022	£299.00	REAR PANEL, complete	1	1967-89
	ALA6417	£299.00	REAR PANEL, complete	1	with alarm bracket 1990 on

Note: The rear panel HMP441046 from BMH is supplied complete with Mkl lamp and bootlid apertures. However, the rear window aperture is only for models from 1967 (MkII) on, when the screen changed to a larger one. The complete rear panel is not available with the original Mkl size rear window aperture as the pressing is made from MklI tooling. If you have a Mkl this panel can be used as a repair section and cut to suit individual requirements.

	GAC8452X	£26.95	LAMP PANEL KIT, welded in	1	retro fit Mkl lamps into MkII & MkIII body
2	HMP441019	£221.50	REAR PANEL, REPAIR	1	1967-On
3	28G110	£333.00	BOOT LID ASSEMBLY	1	1959-69
	HMP441051	£120.00	BOOT LID SKIN, aluminium	1	1959-69
	BMP339	£205.00	BOOT LID ASSEMBLY	1	1970-89
	BMP339Z	£101.30	BOOT LID ASSEMBLY, aftermarket	1	seal on boot lid
	BMD36001	£204.00	BOOT LID ASSEMBLY	1	1990-On seal on bodysell

iii. Part Number Price £ea. Description Req. Details

	BMP102	£64.70	SKIN, boot lid	1	1970-On
4	HMP441009	£203.50	BOOT HINGE PANEL	1	1967-On
5	HMP441026	£85.00	LOWER REAR PANEL CENTRE	1	1967-On hinge panel repair
6	14A5497	£57.00	REAR VALANCE	1	all saloons
	14A6940	£57.00	REAR VALANCE	1	1959-69 no holes
	CZH3353	£57.00	REAR VALANCE	1	1980-On including fog lamp mount
	CZH3353Z	£29.00	REAR VALANCE, reproduction	1	1980-On
7	14A8154	£40.00	REAR APRON CENTRE PANEL	1	all vans & pickups
	14A8154Z	£33.70	REAR APRON CENTRE PANEL	1	
8	14A6908	£23.50	REAR APRON CORNER, RH	1	
	14A6908Z	£16.80	REAR APRON CORNER, RH	1	
9	14A6909	£23.50	REAR APRON CORNER, LH	1	
	14A6909Z	£16.80	REAR APRON CORNER, LH	1	
10	CZH3293	£262.00	TAILGATE	1	pickup
11	14A8096	£272.00	REAR DOOR, RH	1	van & estate
12	14A8097	£272.00	REAR DOOR, LH	1	van & estate
13	14A9023	£72.10	FLOOR EXTENSION	1	commercials
14	14A7555	£227.50	SIDE PANEL, RH	1	pickup
	14A7556	£227.50	SIDE PANEL, LH	1	pickup

Wood Kit Countryman Estate

	HMP341002	£1,145.00	WOOD TRIM KIT	1	
	HMP341002FK	£43.50	FIXING KIT, wood trim	1	

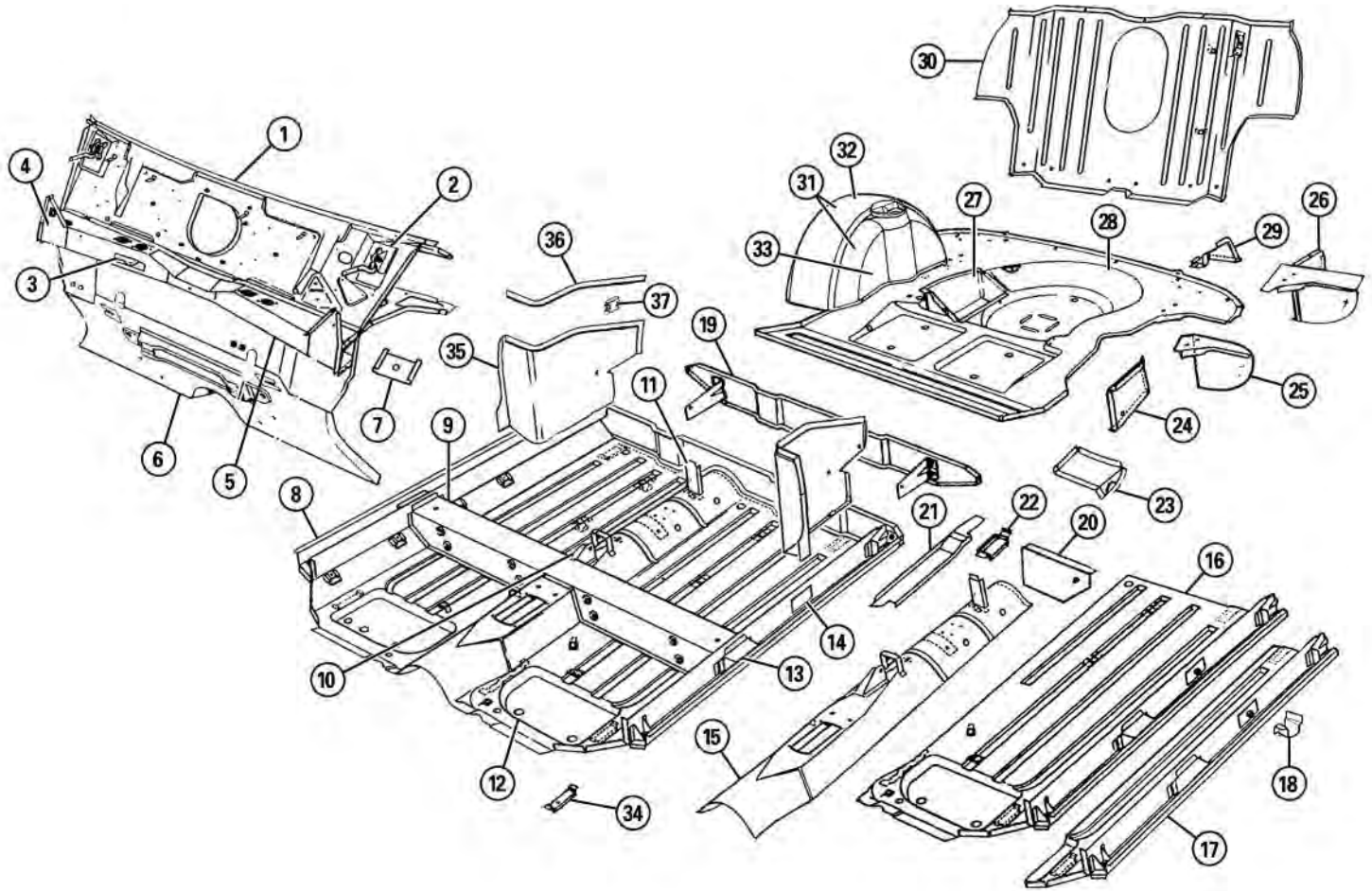

ill.	Part Number	Price £ea.	Description	Req.	Details
Underframe					
1	CZH3216	£462.00	BULKHEAD ASSEMBLY, complete	1	1976-89
	AHA36005	£316.00	BULKHEAD ASSEMBLY, complete	1	1990-On
2	14A7246	£34.00	HINGE, bonnet, RH	1	1959-69
	14A7247	£34.00	HINGE, bonnet, LH	1	
	BMP348	NCA	HINGE, bonnet, RH	1	
	BMP349	NCA	HINGE, bonnet, LH	1	1970-On
	HMP441027	£36.70	HINGE SET, bonnet	1	
3	14A6730	£10.20	BRACKET, engine stabiliser	1	
4	AHP36001	£30.00	BRACKET, crossmember to dash, RH	1	1970-On
	AHP36007	£30.00	BRACKET, crossmember to dash, LH	1	
5	AHC36003R	£61.00	CROSSMEMBER, half, RH	1	1970-On
	AHC36003L	£61.00	CROSSMEMBER, half, LH	1	
6	AHA36006	£107.00	TOEBOARD	1	
	AHA36007	£81.00	TOEBOARD, lower repair section	1	1990-On
7	CZG1496	£1.96	BRACKET, washer bottle	1	
8	14A9534	£41.50	SILL, outer, RH	1	
	14A9534Z	£25.40	SILL, outer, RH, aftermarket	1	
	14A9535	£41.50	SILL, outer, LH	1	
	14A9535Z	£25.40	SILL, outer, LH, aftermarket	1	saloon 1970-On
	HMP441028	£73.81	SILL KIT, outer, pair	1	
	BHM3	£31.30	SILL, outer, RH	1	
	BHM4	£31.50	SILL, outer, LH	1	
	14A9026	£34.00	SILL, outer, RH	1	van & traveller
	14A9027	£34.00	SILL, outer, LH	1	
9	CZH2675	£63.40	CROSSMEMBER, under seat, complete	1	
	CZH2675R	£51.00	CROSSMEMBER, under seat, half, RH	1	1970-On
	CZH2675L	£51.00	CROSSMEMBER, under seat, half, LH	1	
10	CZH3214	£12.00	BRACKET, handbrake mounting	1	
11	14A6624	£10.50	SUPPORT, rear seat to tunnel	1	
12	ADA36002E	£668.00	FLOOR ASSEMBLY, complete	1	1976-89
	ADA36002	£580.00	FLOOR ASSEMBLY, complete	1	1990-On
	CZH2669	£238.50	FLOOR PANEL, main	1	
	HMP441004	£110.50	FLOOR PANEL, half, RH	1	1976-On rod change
	HMP441005	£110.50	FLOOR PANEL, half, LH	1	
13	14A8374	£17.20	EXTENSION, crossmember, RH	1	
	14A8375	£17.20	EXTENSION, crossmember, LH	1	
14	24A2186	£8.00	PLATE, seatbelt mounting	2	1964-On
15	ADA36002EC	£116.00	TUNNEL ASSEMBLY	1	1976-On
	ADA36002C	£116.00	TUNNEL ASSEMBLY	1	1990-On
16	ADA36002RH	£285.00	FLOOR & SILL ASSEMBLY, half, RH	1	1990-On
	ADA36002LH	£285.00	FLOOR & SILL ASSEMBLY, half, LH	1	
17	ADA36002RQ	£227.00	FLOOR & SILL ASSEMBLY, repair, RH	1	1990-On
	ADA36002LQ	£227.00	FLOOR & SILL ASSEMBLY, repair, LH	1	to first groove on floor
18	14A8336	£2.30	JACKING POINT, RH	1	

ill.	Part Number	Price £ea.	Description	Req.	Details
	14A8337	£2.30	JACKING POINT, LH	1	
19	HMP441008	£77.90	HEELBOARD, complete	1	
	HMP441006	£37.80	HEELBOARD, half, RH	1	
	HMP441007	£37.80	HEELBOARD, half, LH	1	
20	MBP9017	£24.00	HEELBOARD, repair, RH	1	
	MBP9018	£24.00	HEELBOARD, repair, LH	1	
21	14A8994	£15.30	CLOSING PANEL, comp. box, RH	1	
	14A8995	£15.30	CLOSING PANEL, comp. box, LH	1	
22	24A42	£7.60	BRACKET, sling, rear, RH	1	
	24A43	£7.60	BRACKET, sling, rear, LH	1	
23	14A6611	£14.60	CLOSING PANEL, wheel arch, RH	1	
	14A6612	£14.60	CLOSING PANEL, wheel arch, LH	1	
24	ALA5532	£13.50	BRACKET, boot floor to bulkhead, RH	1	saloon 1967-On
	ALA5533	£13.50	BRACKET, boot floor to bulkhead, LH	1	
25	ALA5524	£29.80	CLOSING PANEL, plain, rear valance, RH	1	
	MBP9013	£20.40	CLOSING PANEL, plain, rear valance, RH, aftermarket	1	
	ALA5525	£29.80	CLOSING PANEL, plain, rear valance, LH	1	
	MBP9014	£20.40	CLOSING PANEL, plain, rear valance, LH, aftermarket	1	
26	HMP441020	£39.80	CLOSING PANEL ASSEMBLY, rear valance RH (complete with gusset & stiffener)	1	
	HMP441021	£39.80	CLOSING PANEL ASSEMBLY, rear valance, LH (complete with gusset & stiffener)	1	
27	14A6499	£57.60	BATTERY BOX	1	
	14A6499Z	£26.20	BATTERY BOX, aftermarket	1	
28	HMP441016	£241.90	BOOT FLOOR ASSEMBLY (with battery box)	1	
	ALA5513	£203.50	BOOT FLOOR ASSEMBLY (without battery box)	1	
29	14A6609	£21.00	BRACKET, rear subframe mounting, RH	1	
	14A6610	£21.00	BRACKET, rear subframe mounting, LH	1	
	24A2204	£153.00	BULKHEAD, seat back	1	
	14A9558	£95.00	WHEEL ARCH ASSEMBLY, rear, RH	1	
	14A9559	£95.00	WHEEL ARCH ASSEMBLY, rear, LH	1	
32	14A6617	£40.00	WHEEL ARCH, outer, rear, RH	1	
	14A6618	£40.00	WHEEL ARCH, outer, rear, LH	1	
33	HMP441010	£54.10	TURRET, shock absorber mount, RH	1	
	HMP441011	£54.10	TURRET, shock absorber mount, LH	1	
	MBP9009	£35.60	TURRET, shock absorber mount, universal	2	
34	24A41	£7.60	BRACKET, sling, front	2	
35	ADO360020	£39.50	COMPANION BOX ASSEMBLY, RH	1	1990-On
	ADO360030	£39.50	COMPANION BOX ASSEMBLY, LH	1	
	ALA5828	£12.00	FINISHER, companion box, RH	1	
	ALA5829	£12.00	FINISHER, companion box, LH	1	
37	EYC10048	£2.23	CLIP, finisher	10	

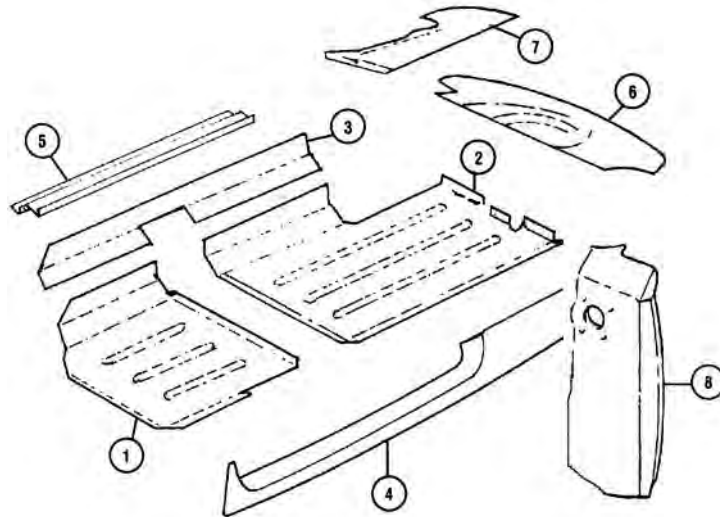

ill.	Part Number	Price £ea.	Description	Req.	Details
Underframe Repair Panels					
1	BHM9	NCA	FLOOR PAN, front, RH	1	1969-On
	BHM9Z	£43.50	FLOOR PAN, front, RH, aftermarket	1	1969-On
	BHM10	NCA	FLOOR PAN, front, LH	1	1969-On
	BHM10Z	£43.50	FLOOR PAN, front, LH, aftermarket	1	1969-On
2	BHM11	£62.95	FLOOR PAN, rear, RH	1	1969-On, saloon only
	BHM11Z	£58.30	FLOOR PAN, rear, RH, aftermarket	1	1969-On, saloon only
	BHM12	£60.10	FLOOR PAN, rear, LH	1	1969-On, saloon only
	BHM12Z	£58.30	FLOOR PAN, rear, LH, aftermarket	1	1969-On, saloon only
3	MBP9023	£26.20	FLOOR EDGE INNER, RH	1	1969-On

ill.	Part Number	Price £ea.	Description	Req.	Details
	MBP9024	£26.20	FLOOR EDGE INNER, LH	1	1969-On
4	MBP9015	£60.40	DOOR STEP & QUARTER, repair, RH	1	1969-On
	MBP9016	£60.40	DOOR STEP & QUARTER, repair, LH	1	1969-On
5	BHM13	NCA	DOOR STEP, repair, OE	1	1969-On
	BHM13Z	£72.60	DOOR STEP, repair, aftermarket	1	1969-On
6	MBP9010	£35.00	BOOT FLOOR EDGE	1	1969-On
7	MBP9011	£23.80	BOOT FLOOR CORNER, RH	1	1969-On
	MBP9012	£23.80	BOOT FLOOR CORNER, LH	1	1969-On
8	ALA6278RP	£34.40	INNER WING, repair, RH	1	1969-On
	ALA6279RP	£34.40	INNER WING, repair, LH	1	1969-On

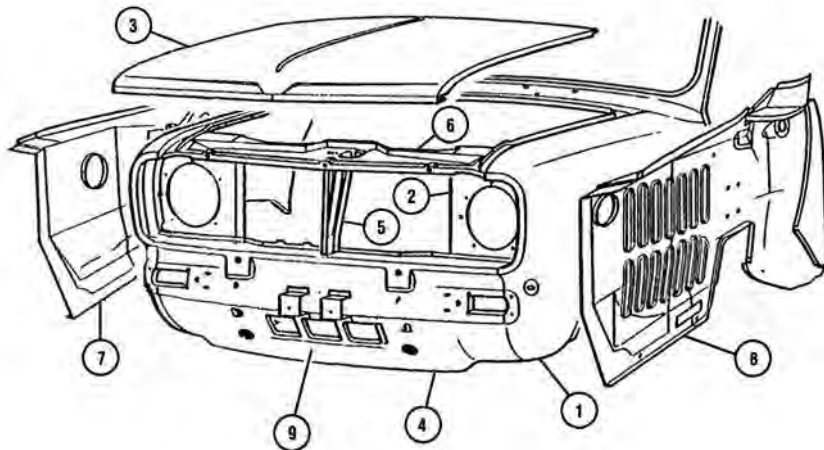

ill.	Part Number	Price £ea.	Description	Req.	Details
Front Body Panels Clubman					
1	CZH408	£117.30	FRONT WING, RH	1	
	CZH409	£117.30	FRONT WING, LH	1	
2	CZH120	£16.40	HEADLAMP MOUNTING, RH	1	
	CZH121	£16.40	HEADLAMP MOUNTING, LH	1	
3	CZH2609	£177.00	BONNET ASSEMBLY	1	
4	CZH563	£122.00	FRONT LOWER PANEL	1	1970-76
	AAM1022	£116.00	FRONT LOWER PANEL	1	1976-83

ill.	Part Number	Price £ea.	Description	Req.	Details
5	CZH155	£33.00	BONNET SUPPORT PANEL	1	
6	CZH149	£47.00	BONNET LANDING PANEL	1	
7	CZH410	£245.00	INNER WING WITH A POST, RH	1	
8	CZH567	£263.00	INNER WING WITH A POST, LH	1	
9	HMP441039	£241.50	FRONT PANEL COMPLETE*	1	1970-75
	HMP441040	£241.50	FRONT PANEL COMPLETE*	1	1976-83

*(Includes CZH120, CZH121, CZH563, CZH155 and CZH149).

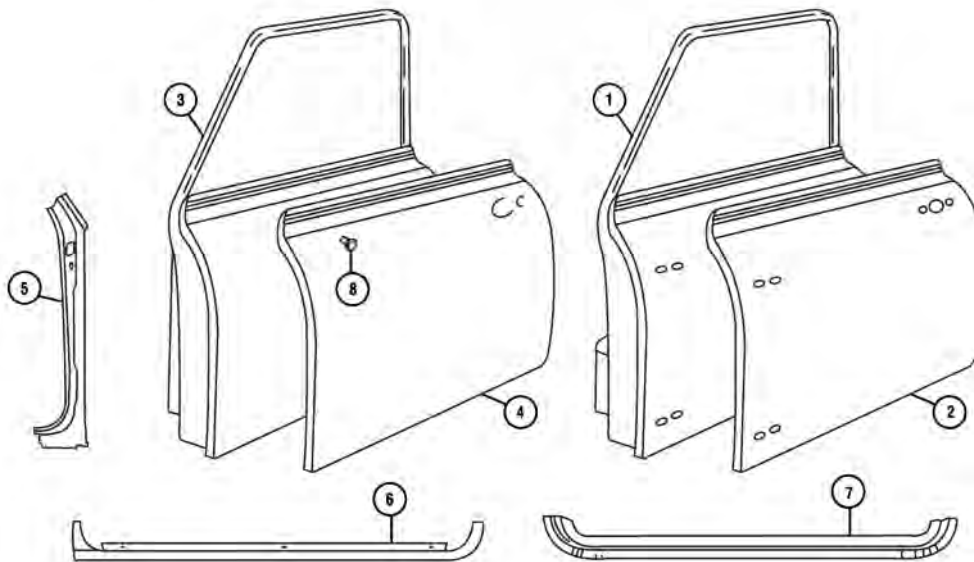

ill.	Part Number	Price £ea.	Description	Req.	Details
Doors					
1	14A8306	£620.00	DOOR ASSEMBLY, RH	1	1959-69
	14A8307	£620.00	DOOR ASSEMBLY, LH	1	1959-69
2	14A5498	£89.00	DOOR SKIN, RH	1	1959-69
	14A5498Z	£50.00	DOOR SKIN, RH, aftermarket	1	1959-69
	HMP441052	£125.00	DOOR SKIN, RH, aluminium	1	1959-69
	14A5499	£89.00	DOOR SKIN, LH	1	1959-69
	14A5499Z	£50.00	DOOR SKIN, LH, aftermarket	1	1959-69
	HMP441053	£125.00	DOOR SKIN, LH, aluminium	1	1959-69
3	BMP326	£470.00	DOOR ASSEMBLY, RH	1	1970-89
	BMP327	£470.00	DOOR ASSEMBLY, LH	1	1970-89
	BDA360100	£470.00	DOOR ASSY. & CRASH BAR, RH	1	1990-0n
	BDA360110	£470.00	DOOR ASSY. & CRASH BAR, LH	1	1990-0n

ill.	Part Number	Price £ea.	Description	Req.	Details
4	CZH3300	£86.40	DOOR SKIN, RH	1	1970-On
	CZH3300Z	£49.00	DOOR SKIN, RH	1	1970-On
	CZH3300AL	£57.30	DOOR SKIN, alloy, RH	1	1970-On
	CZH3301	£86.40	DOOR SKIN, LH	1	1970-On
	CZH3301Z	£49.00	DOOR SKIN, LH	1	1970-On
	CZH3301AL	£57.30	DOOR SKIN, alloy, LH	1	1970-On
5	14A8349Z	£33.80	DOOR JAMB, repair, RH	1	1970-On
	14A8348Z	£35.20	DOOR JAMB, repair, LH	1	1970-On
6	CZH3355Z	£18.70	DOOR INNER, repair, LH	1	1970-On
	CZH3356Z	£18.90	DOOR INNER, repair, RH	1	1970-On
7	14A8307RP	£66.50	LOWER DOOR, repair, RH	1	1959-69
	14A8306RP	£66.30	LOWER DOOR, repair, LH	1	1959-69
	CZH3350Z	£26.30	DOOR BOTTOM, repair, LH	1	1970 On
	CZH3351Z	£26.30	DOOR BOTTOM, repair, RH	1	1970 On
8	ADU2038	£0.73	RIVET NUT, door mirror	a/r	

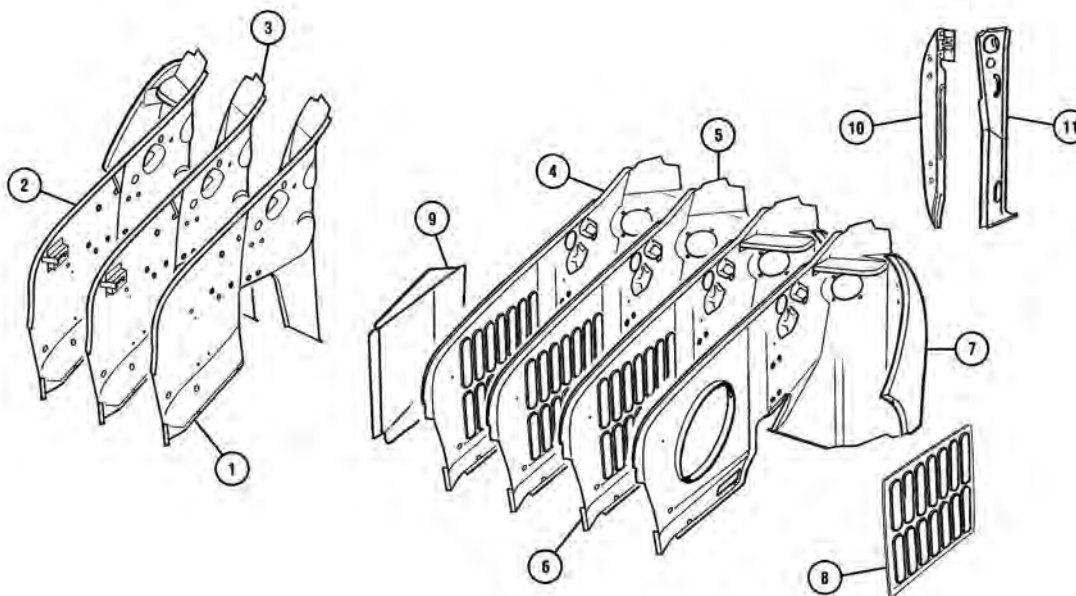

ill.	Part Number	Price £ea.	Description	Req.	Details
Inner Wings					
1	14A7900	£124.00	INNER WING, without A panel, RH	1	1959-69
	ABD36008	NCA	INNER WING, without A panel, RH	1	1969-0n
2	ABD36004	£215.00	INNER WING ASSY., with A panel, RH	1	1969-0n
3	ABD36006	£168.00	INNER WING ASSY., without A panel, RH	1	1969-0n
4	14A7901	£157.00	INNER WING, without A panel, LH	1	1959-69
	ALA6271	£124.00	INNER WING, without A panel, LH	1	1969-89
	ABD36009	£111.30	INNER WING, without A panel, LH	1	1990-96
	ABD360180	£124.00	INNER WING, without A panel, LH	1	1997-0n
5	ABD36007	£168.00	INNER WING, without A panel, LH	1	1990-96 with fan hole

ill.	Part Number	Price £ea.	Description	Req.	Details
6	ALA6279	£215.20	INNER WING ASSY., with A panel, LH	1	1969-89
	ABD360200	£215.00	INNER WING ASSY., with A panel, LH	1	1997-0n
7	ABD36005	£215.00	INNER WING ASSY., with A panel, LH	1	1990-96 with fan hole
8	HMP441023	£49.80	PANEL COOLING SLATS	1	1959-89
9	14A6498	£64.00	RADIATOR COWLING	1	1959-75
10	ALA6472	£27.30	A POST INNER STIFFENER, RH	1	1970-On
	MBP9003	£21.00	A POST INNER STIFFENER, RH	1	1970-On, aftermarket
	ALA6473	£27.30	A POST INNER STIFFENER, LH	1	1970-On
	MBP9004	£37.00	A POST INNER STIFFENER, LH	1	1970-On, aftermarket
11	ALA5686	£16.30	BOXING PLATE A PANEL, RH	1	1970-On
	ALA5687	£16.30	BOXING PLATE A PANEL, LH	1	1970-On

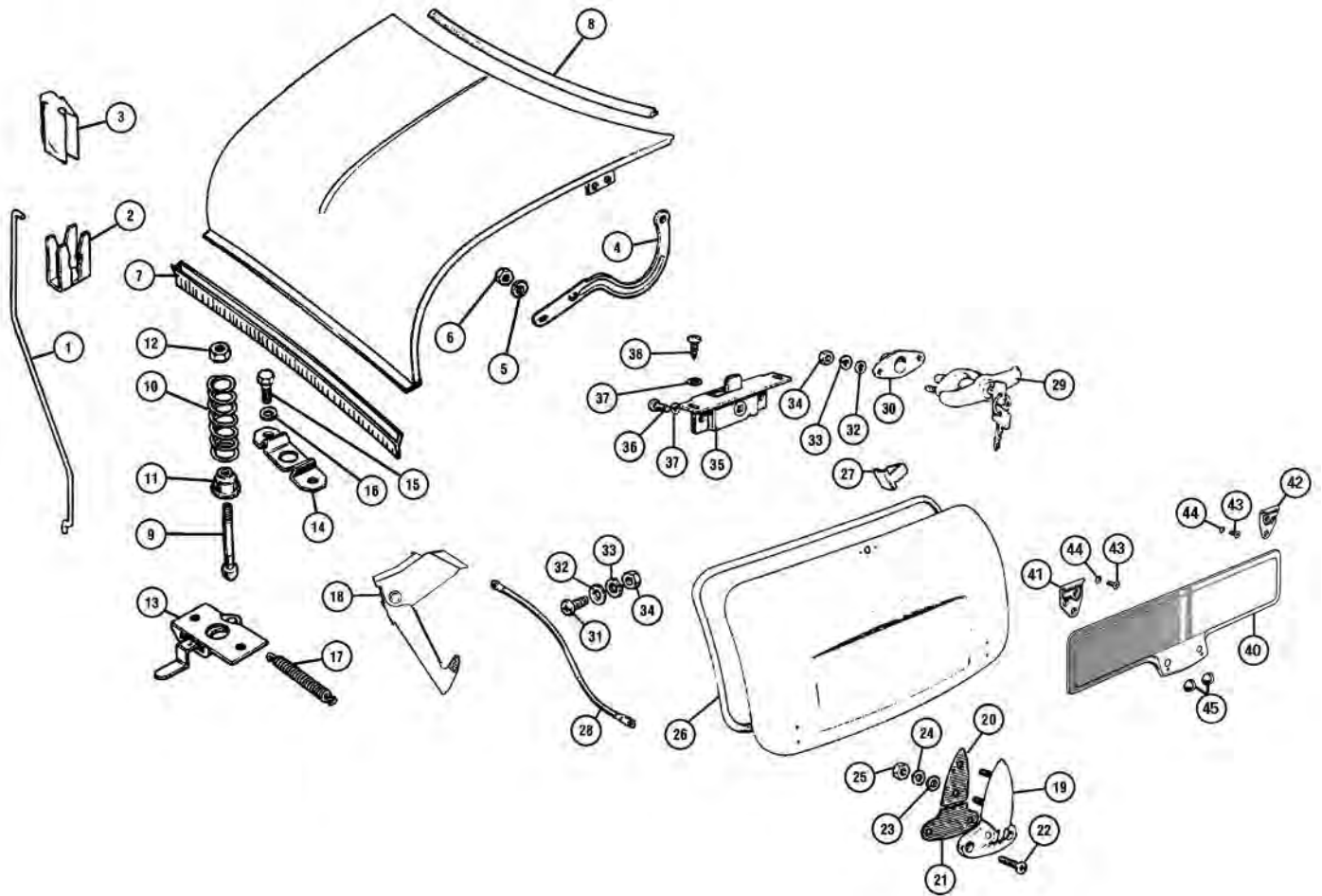

ill.	Part Number	Price £ea.	Description	Req.	Details
Body Fittings					
1	BKD360030	£11.00	STAY, bonnet	1	
2	24A859	£2.10	CLIP, stay to bonnet, metal	1	
3	GFK7344	£1.66	CLIP, stay retaining, rubber	1	
	GHF504	£0.19	SPLIT PIN, retainer	a/r	
4	14A7246	£34.00	HINGE, bonnet, RH	1	1959-69
	14A7247	£34.00	HINGE, bonnet, LH	1	
	BMP348	NCA	HINGE, bonnet, RH	1	1970-On
	BMP349	NCA	HINGE, bonnet, LH	1	
	MSSK019	£34.00	HINGE KIT, quick release	1	
5	PWZ204	NCA	WASHER	4	
6	GHF200	£0.19	NUT	4	
7	JRC7898	£8.10	SEAL, bonnet, front	1	
8	14A9010	NCA	SEAL, bonnet, rear, self adhesive	1	scuttle panel drain to 1991
	CJE10021	£5.22	SEAL, bonnet, rear, self adhesive	1	scuttle panel drain 1992-On
	JRC7008	£10.80	SEAL, bonnet, rear, rubber	1	bonnet lip, 1980-On
	BHH626M	£3.32	SEAL, bonnet, rear, per metre	1	
9	14A6586	£7.00	PIN, bonnet	1	
10	FPQ10001	£2.90	SPRING	1	
11	ADA458	£9.70	SPRING CUP	1	
12	ND606041	£1.15	LOCK NUT	1	
13	AAM1206	£27.50	CATCH	1	
14	AAM1223	£4.40	GUIDE	1	
15	SH604051	£0.28	SCREW, catch and guide to body	2	
16	GHF331	£0.17	WASHER, locking	2	
17	4G2494	£2.40	SPRING, catch return	1	alternatives
	24G3591	£4.96	SPRING, catch return	1	
18	ALA7608	£20.00	HOOK	1	
	MCR108	£13.64	CABLE, bonnet release	1	
	GAC8425X	£32.00	BONNET RELEASE KIT	1	
19	HMP441031	£12.40	HINGES, boot, (pair)	1	
	MT8101	£14.00	HINGES, boot, (pair)	1	chrome plated
20	BMP401	£0.46	GASKET, upper hinge	1	
21	BMP402	£1.40	GASKET, lower hinge	1	
22	SG604051	£1.04	SCREW	4	
23	GHF300	£0.19	WASHER	4	

ill.	Part Number	Price £ea.	Description	Req.	Details
24	GHF331	£0.17	WASHER, locking	4	
25	GHF200	£0.19	NUT	4	
26	14A6584	£8.90	SEAL, boot lid, fitted to boot lid	1	To VIN 398599
	CKE10018	£8.40	SEAL, boot lid, fitted to body	1	From VIN 398600
27	14A6585	£0.68	CLIP, seal to boot lid	a/r	use with seal 14A6584
28	MCR107	£4.00	CABLE, boot lid check strap	2	
29	JRC2844	£57.00	HANDLE, boot lid, chrome	1	To 1980
	JRC2843	£54.00	HANDLE, boot lid, black	1	1980-84
	JRC8182	£62.10	HANDLE, boot lid, nimbus	1	1984-On
	14A7194	£59.40	HANDLE, boot lid, chrome	1	1959-69
30	CZH1747	£0.60	SEAL, handle to boot	1	
31	PMZ314	£0.28	SCREW, cable to body	2	
	PMZ308	£0.28	SCREW, cable to boot lid	2	
32	PWZ203	£0.17	WASHER, plain	6	
33	WL700101	£0.19	WASHER, locking	6	
34	GHF206	£0.13	NUT	6	
35	14A5696	£34.00	LATCH, boot Lock	1	
36	PMZ307	£0.48	SCREW, latch to boot lid	2	
37	WF702101	£0.32	WASHER, locking	a/r	
38	GHF425	£0.19	SCREW, self tapping	2	
40	14A6468	£15.00	BACKING PLATE, number plate	1	
41	14A6466	£7.45	HINGE, number plate, RH	1	
42	14A6467	£7.45	HINGE, number plate, LH	1	Mkl-II,
43	CMZ308	£0.28	SCREW, hinge to bootlid	6	not MklI Germany
44	WL700101	£0.19	WASHER	6	
45	14A7625	£2.30	BUFFER, number plate	2	

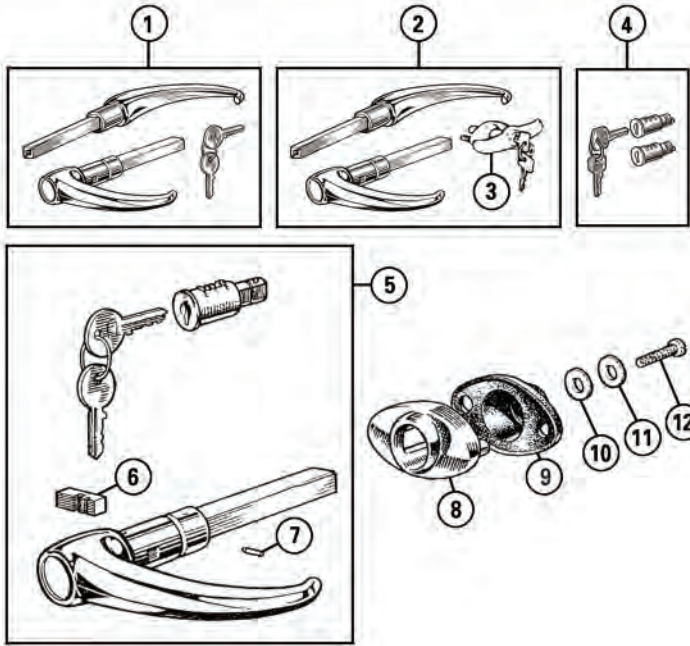

MkI 1959-65

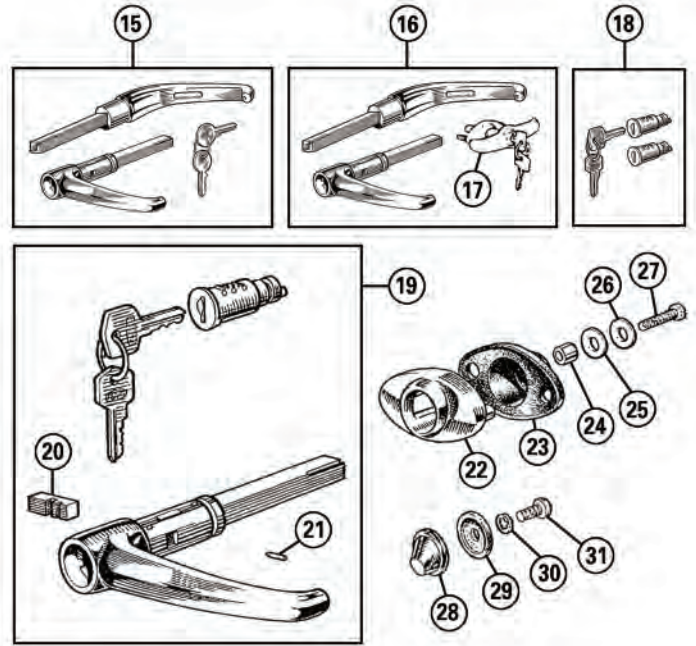

MkII 1966-On

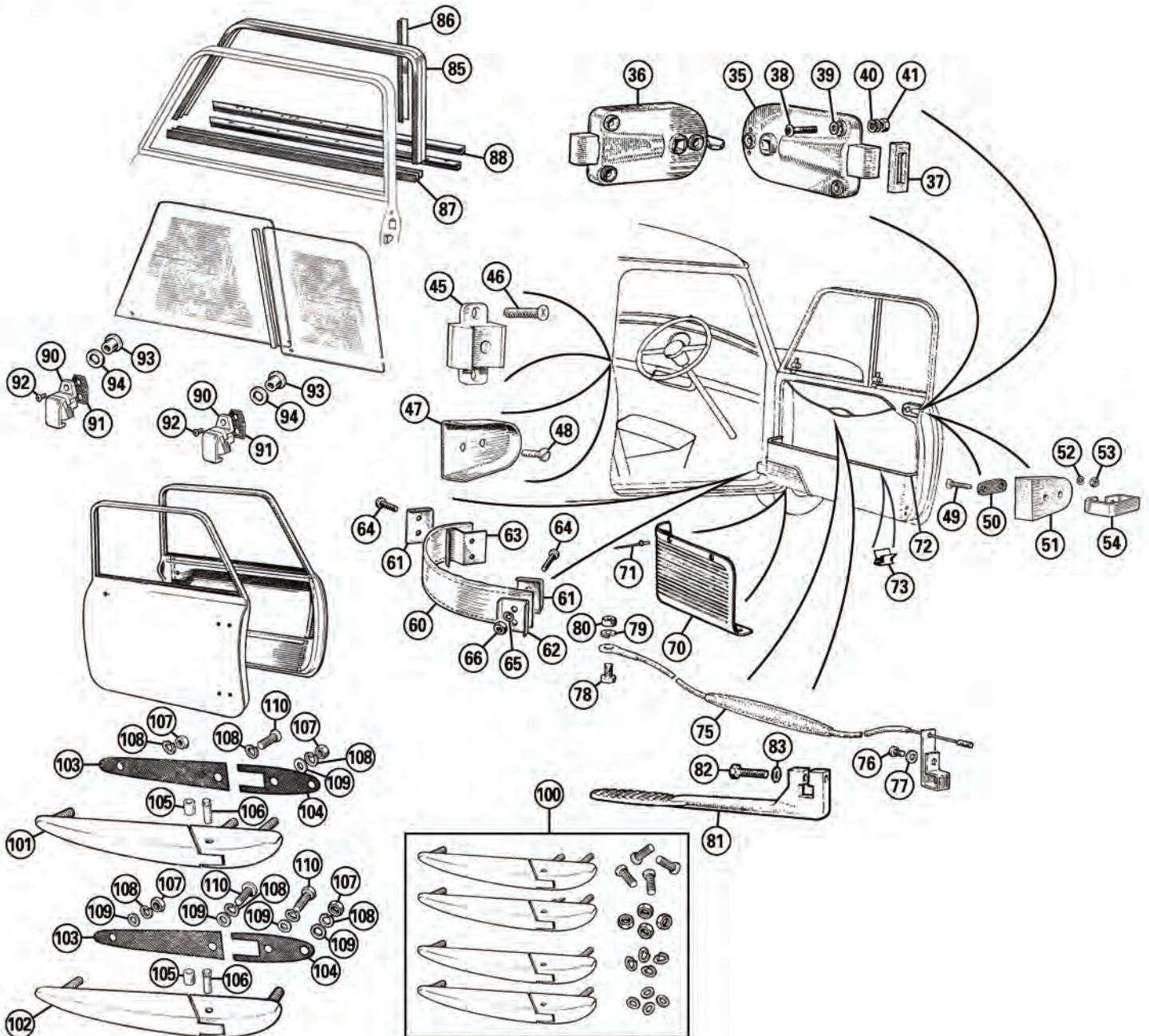

ill. Part Number Price £ea. Description Req. Details

Door Handles & Locks

There are two different types of door handles for the early MkI-II door. The early type, 1959-65, was a standard door handle whereas from 1966 onwards a safety boss (to stop people catching themselves on the early handle) was fitted to the door skin, under the end of the handle. This meant a shorter door handle was made to allow fitment for the boss. Originally only one lock was fitted to these cars, the exterior handle on the driver's side and the interior passenger side. In the inside of the car, the reverse was the case, with the passenger's lock assembly incorporating a safety catch and the driver's side lock assembly not. All door handles we now supply are of the locking type.

Door Handles & Seals

MkI, 1959 - 1965

1	24A1140P	NCA	HANDLE SET, doors only	1	2 piece, with keys
2	24A1140S	£116.30	HANDLE SET, doors & boot	1	3 piece, with keys
3	14A7194	£59.40	HANDLE, boot lid, chrome, with key	1	MkI-II, 1959-65
4	24A1140LB	£45.60	LOCK BARREL SET, 2 piece, with keys	1	
5	24A1140	£32.40	DOOR HANDLE, locking, RH, with keys	1	
	14A6829	£32.40	DOOR HANDLE, locking, LH, with keys	1	
6	17H6596	NCA	BOLT, locking	2	
7	27H8618	NCA	PIN, retaining	2	
8	24A2245	£12.60	ESCUTCHEON, locking handle	1	MkI-II
	24A2246	£12.60	ESCUTCHEON, non locking handle	1	
9	ADA3817	£3.08	SEAL, escutcheon to door	2	
10	PWZ203	£0.17	WASHER, plain	4	
11	WL700101	£0.19	WASHER, locking	4	to 1966
12	PMZ308	£0.28	SCREW, escutcheon to door	4	

MkI-II, 1966-On

15	24A2083P	NCA	HANDLE SET, doors only	1	2 piece, with keys
16	24A2083S	£115.20	HANDLE SET, doors & boot	1	3 piece, with keys
17	14A7194	£59.40	HANDLE, boot lid, chrome, with key	1	MkI-II, 1966-70
18	24A1140LB	£45.60	LOCK BARREL SET, 2 piece, with keys	1	
19	24A2083	£36.00	DOOR HANDLE, RH, with keys	1	
	24A1833	NCA	DOOR HANDLE, LH, with keys	1	
20	17H6596	NCA	BOLT, locking	2	
21	27H8618	NCA	PIN, retaining	2	
22	24A2245	£12.60	ESCUTCHEON, locking handle	1	MkI-II
	24A2246	£12.60	ESCUTCHEON, non locking handle	1	
23	ADA3817	£3.08	SEAL, escutcheon to door	2	
24	24A2086	NCA	SPACER	4	
25	PWZ203	£0.17	WASHER, plain	4	1966-On
26	WL700101	£0.19	WASHER, locking	4	
27	PMZ308	£0.28	SCREW, escutcheon to door	4	
28	24A1834	£9.60	BOSS, door handle	2	
29	24A1835	£1.25	SEAL, boss to door	2	1966-On
30	WL700101	£0.19	WASHER, shakeproof	2	
31	PMZ308	£0.28	SCREW	2	

Door Lock Assembly

35	24A2145	NCA	LOCK ASSEMBLY, no safety catch, RH	1	RHD, drivers side
	24A2146	£36.00	LOCK ASSEMBLY, no safety catch, LH	1	LHD, drivers side
36	24A2144	£36.00	LOCK ASSEMBLY, safety catch, LH	1	RHD, passengers side
	24A2143	£36.00	LOCK ASSEMBLY, safety catch, RH	1	LHD, passengers side
37	14A8568	NCA	SEAL, lock to door	2	
38	RMZ316	£1.70	SCREW	6	
39	PWZ103	£0.19	WASHER, plain	2	
40	WL700101	£0.19	WASHER, spring	2	
41	FNZ103	£0.28	NUT	2	

Door Lock Strikers

45	14A6832	NCA	STRIKER PLATE, door lock	2	
46	RMZ310	£0.62	SCREW, striker plate retainer	6	
47	14A6835	£3.40	PLATE, buffer	2	
48	CMZ204	£0.42	SCREW, buffer plate retainer	4	
49	CMZ210	NCA	SCREW, buffer to door	4	
50	14A6834	NCA	PLATE, buffer fixing	2	
51	14A6833	£3.20	BUFFER, nylon	2	
52	WL700101	£0.19	WASHER, locking	4	
53	CNZ102	£0.28	NUT	4	
54	14A7680	NCA	PLATE, tapped, buffer inside door	2	

Check Straps

60	ALE1221	£11.50	CHECK STRAP, black	2	
	14E4289	£15.00	CHECK STRAP, red	2	
	DC3005P	£11.50	CHECK STRAP, grey	2	
61	14A764	£1.80	BRACKET, check strap, 2 per strap	4	
62	14A6744	£2.20	BRACKET, check strap	2	1959-69
63	14A6745	£2.15	BRACKET, check strap	2	
64	SG604083	£1.32	SCREW, countersunk, chrome	8	
65	GHF331	£0.17	WASHER, spring	4	
66	GHF200	£0.19	NUT	4	

ill. Part Number Price £ea. Description Req. Details

Kick Plate & Trim

70	14A7176	£24.00	KICK PLATE, RH	1	
	14A7177	£24.00	KICK PLATE, LH	1	1959-69
71	GHF600	£0.13	RIVET, kick plate to door pocket	8	
72	24A1169	£13.70	FINISHER, door pocket, chrome	2	MkI-II, van &
73	EYC10048	£2.23	CLIP, door pocket	8	pick-up

Interior Door Pulls

75	24A664	NCA	CABLE, door pull	2	
76	PMZ308	£0.28	SCREW, clamping cable to lock	2	1959-68, standard,
77	PWZ103	£0.19	WASHER, plain	2	deluxe, van &
78	PMZ308	£0.28	SCREW, cable to door	2	pick-up models
79	WL700101	£0.19	WASHER, locking	2	
80	FNZ103	£0.28	NUT	2	
81	GLZ119A	£28.00	HANDLE, interior, black	2	
82	PMZ314	£0.28	SCREW, clamping handle to lock	2	1968-On, all models
83	WE702101	£0.28	WASHER, shakeproof	2	

Window Channel

85	14A7167	NCA	CHANNEL UPPER	2	
	14A7167Z	£16.50	CHANNEL UPPER	2	aftermarket
86	EAM8530	£10.00	WEATHER STRIP, RH/LH	2	
87	24A88	£22.00	CHANNEL, lower	2	
88	24A1303	£20.70	CHANNEL PLATE, RH	1	1961-On
	24A1304	£20.70	CHANNEL PLATE, LH	1	

Window Catch

90	24A1194	£7.25	WINDOW CATCH, front, RH	1	
	24A1195	£7.25	WINDOW CATCH, front, LH	1	
	24A1196	£7.25	WINDOW CATCH, rear, RH	1	
	24A1197	£7.25	WINDOW CATCH, rear, LH	1	1963-On
91	24A1198	£3.50	SEAL, catch to glass	4	
92	RMP307	£2.32	SCREW, window catch	4	
93	14A8151	£5.20	BOSS, window catch, chrome	4	
94	14A7065B	£0.60	WASHER, for chrome boss	4	

Early Door With External Hinges

100	14A6818KA	£135.00	HINGE SET, external	1	
101	14A6818	NCA	HINGE, RH, upper	1	
	14A6819	NCA	HINGE, LH, upper	1	
102	14A6820	NCA	HINGE, RH, lower	1	
	14A6821	NCA	HINGE, LH, lower	1	
103	BMP134	£0.73	GASKET, large	4	
104	BMP135	£0.89	GASKET, small	4	1959-69
105	37H3043	£1.80	BUSH, hinge, repair	4	
106	37H3044	£1.32	PIN, hinge, repair	4	
107	GHF200	£0.19	NUT	10	
108	GHF331	£0.17	WASHER, spring	16	
109	GHF300	£0.19	WASHER, flat	12	
110	SE604061	£0.62	SCREW, pan head	6	

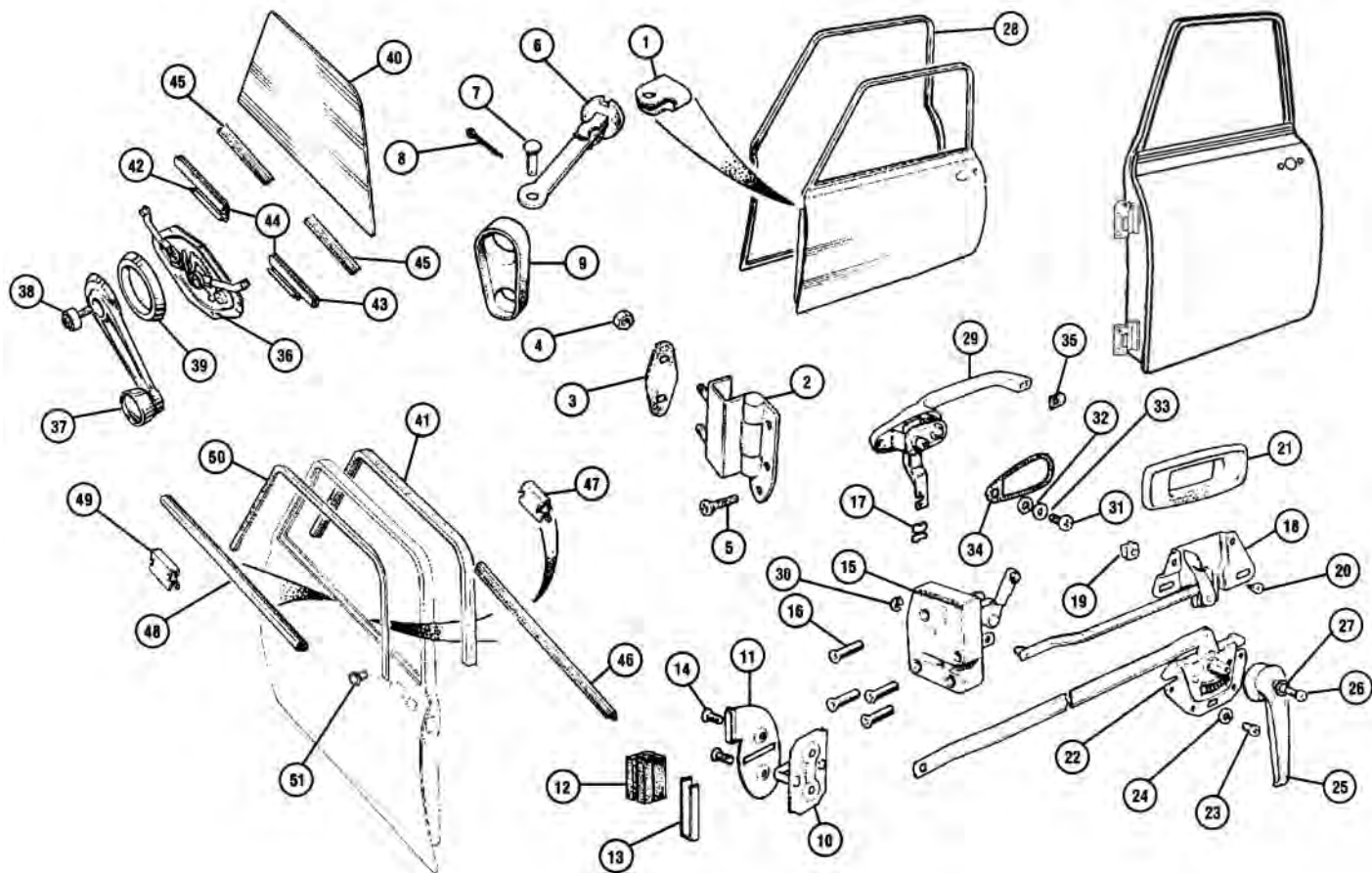

ill.	Part Number	Price £ea.	Description	Req.	Details
Door Fittings					
Later Door With Internal Hinges					
1	CZH3121	£6.46	BRACKET, check arm	2	
2	HMP441030	£180.00	HINGE SET, upper & lower	1	
	CZH202	£32.15	HINGE, upper, RH	1	OE
	CZH203	£32.15	HINGE, upper, LH	1	from 1970
	CZH212	£30.30	HINGE, lower	2	
	CZH202K	£18.10	HINGE SET, RH, pair	1	aftermarket
	CZH203K	£18.10	HINGE SET, LH, pair	1	from 1970
			(The RH & LH hinge sets include a lower and handed upper hinge).		
3	ALA6381	£2.40	WASHER, door hinge	a/r	
4	GHF221	£0.37	NUT, nyloc, hinge to body	8	
5	SF604061	£0.37	SCREW, hinge to door	10	
6	ADA5671	£16.00	CHECK STRAP, door	2	
7	CLZ413	£1.20	CLEVIS PIN, check strap to body	2	
8	GHF500	£0.19	SPLIT PIN	2	
9	CZH4052	£4.00	SEAL, check strap, rubber, RH	1	To VIN 324224
	CZH4053	£4.00	SEAL, check strap, rubber, LH	1	
	CGE10038	£5.50	SEAL, check strap, foam, RH	1	From VIN 324225
	CGE10039	£5.50	SEAL, check strap, foam, LH	1	
10	CZH627	£16.80	STRIKER, door lock	2	
11	CZD1184	NCA	STRIKER PLATE, RH	1	
	CZD1185	NCA	STRIKER PLATE, LH	1	
	CZG5254	£1.32	STRIKER PLATE	2	1990-On
12	CZD1351	NCA	BUFFER, door to striker plate	2	
13	CZD1350	NCA	RETAINER, door buffer	2	
14	SF604051	£0.28	SCREW, striker to B post	4	
	CZH628	NCA	PLUG, B post, behind catch	2	
15	CZH3528	£87.00	LOCK ASSEMBLY, RH	1	
	CZH3529	£87.00	LOCK ASSEMBLY, LH	1	
16	ZCT410	£1.36	SCREW, lock to door	8	
17	37H6519	NCA	RETAINER, operating link	2	
18	CZH616	£3.92	LOCK CONTROL, RH	1	
	CZH617	£3.92	LOCK CONTROL, LH	1	
19	GHF1030	£0.54	NUT, plastic	4	alternative
20	AB608031	£0.19	SCREW, self tapping	4	door lock to frame
21	CZH611PA	£12.00	BEZEL, lock control, plastic	2	
22	CZH640	£5.35	RELEASE MECHANISM, RH	1	
	CZH641	£5.35	RELEASE MECHANISM, LH	1	
23	PMZ305	£0.32	SCREW, release mechanism	4	
24	WL700101	£0.19	WASHER, locking	4	
25	JPC8387PA	£6.30	HANDLE, opening, black	2	plastic
26	PMP308	£0.62	SCREW, release handle to spigot	2	
27	WE702101	£0.28	WASHER, locking	2	
28	24A1351	£11.20	SEAL, door aperture, black	2	Mkl 1959-69

ill.	Part Number	Price £ea.	Description	Req.	Details
	CFB10047	£14.50	SEAL, door aperture, black	2	
29	CZH886	£57.00	HANDLE, locking, chrome, RH	1	
	CZH887	£57.00	HANDLE, locking, chrome, LH	1	
	CZH886/7	£91.80	HANDLES, chrome, (pair)	1	1970-On inc: keys
	JRC2841/2	£60.00	HANDLES, black, (pair)	1	1970-On inc: keys
	CZH1784S	£98.90	HANDLE SET, chrome, Mkl boot handle	1	1970-On
	WPA9019X	£144.00	HANDLE SET, chrome, Mkill boot handle	1	1970-On
	CZH1785LB	£55.20	BARREL SET	1	1970-On includes doors & boot
30	13H2899	£1.66	LINK CLIP	4	
Note: We supply exterior lock sets with matching keys.					
31	PMZ306	£0.42	SCREW, exterior handle to door	4	
32	WL700101	£0.19	WASHER, locking	4	
33	GHF306	£0.28	WASHER	4	
34	ALA5795	£1.45	GASKET, handle large	2	
35	CZH1729	£1.04	GASKET, handle small	2	
36	CZH646	£84.20	REGULATOR, RH	1	
	CZH647	£71.40	REGULATOR, LH	1	
Note: See Accessories section for electric window kits.					
37	CZA7109	£4.94	HANDLE, window winder	2	
	YGA4330	£9.70	HANDLE, window winder	2	late type
38	ZKC3317	£2.00	SCREW, window winder handle	2	
39	CZH701PA	£5.40	HANDLE SURROUND, black	2	
	GAC8495X	£77.10	HANDLE SET, alloy	1	8 piece set
			(Includes winders, openers, door pulls and lock bezels).		
40	ALA5723	£41.00	DOOR GLASS, RH/LH	2	clear
	CZH4007	£65.00	DOOR GLASS, RH/LH	2	green tint
41	PAM3076	£11.50	RUBBER SEAL, glass upper, RH	1	
	PAM3077	£11.50	RUBBER SEAL, glass upper, LH	1	
42	ALA5746	£34.90	CHANNEL, lower glass, front	2	
43	ALA5747	NCA	CHANNEL, lower glass, rear	2	
44	ALA5746/7	£41.30	CHANNEL SET, lower glass, (pair)	2	
45	37H4297	£3.18	GLAZING STRIP, rubber	4	0.5m length
46	EJU10003	£15.50	WEATHER STRIP, inner	2	with moulding
47	EYC10048	£2.23	CLIP, inner weather strip	a/r	
48	PAM1014	£17.00	WEATHER STRIP, outer, RH	1	
	PAM1015	£17.00	WEATHER STRIP, outer, LH	1	
	HMP841007	£60.00	WEATHER STRIP KIT	1	stainless steel
			(Includes pair of outer weather strips & clips).		
49	ADH3809	£0.50	CLIP, outer moulding	a/r	
50	MS67	£37.00	MOULDING, frame surround, RH	1	1970-On
	MS68	£37.00	MOULDING, frame surround, LH	1	
51	13H743	£1.30	CLIP, frame surround	24	

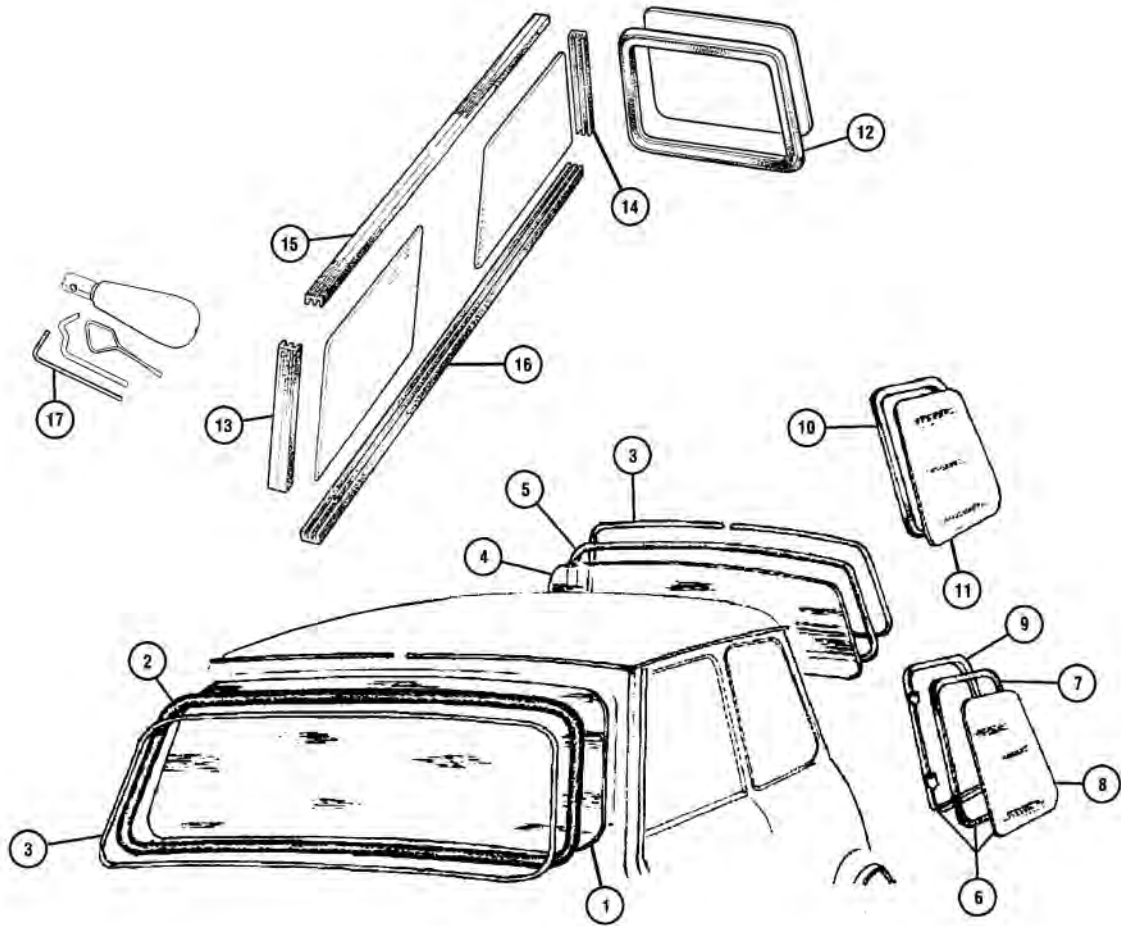

ill.	Part Number	Price £ea.	Description	Req.	Details
Glazing					
Windscreen, Side & Rear Glass					
1	24A2236	£53.80	WINDSCREEN, laminated	1	clear
	24A2236H	£193.40	WINDSCREEN, laminated, heated	1	clear
	24A2236HM	£269.60	WINDSCREEN, laminated, heated	1	clear Monte Carlo style
	CZH4048	£55.90	WINDSCREEN, laminated	1	green tint
	CZH4048H	£211.80	WINDSCREEN, laminated, heated	1	green tint
	MS85	£62.00	WINDSCREEN, laminated	1	green tint/green top tint
	MS85H	£213.00	WINDSCREEN, laminated, heated	1	green tint/green top tint
2	JRC2671	£13.20	SEAL, windscreen, front	1	
	CCB100130	£14.60	SEAL, windscreen, front	1	latest wide type seal
3	24A1466	£4.52	FILLER STRIP, front, chrome	2	pre-cut for front
	24A1466R	£5.12	FILLER STRIP, rear, chrome	2	pre-cut for rear
	JPC2017	£7.00	CLIP, filler strip end finisher	2	
4	13H7323	£71.30	REAR SCREEN, heated	1	clear
	CZH4013	£92.80	REAR SCREEN, heated	1	green tint

Note: Special shipping applies to all windscreens. Please see page 02 for more information.

2	14A8744	£17.30	SEAL, rear screen	1	1959-67
	JRC2674	£12.55	SEAL, rear screen	1	1967-On
6	CZH3522	£268.40	QUARTER LIGHT, RH	1	clear
	CZH3523	NCA	QUARTER LIGHT, LH	1	clear
	JRC5142	NCA	GLASS, quarter light	2	clear
	CZH4010	NCA	QUARTER LIGHT, RH	1	green tint

ill.	Part Number	Price £ea.	Description	Req.	Details
	CZH4011	NCA	QUARTER LIGHT, LH	1	green tint
	JRC5143	£31.10	GLASS, quarter light	2	green tint
7	24A2131	£4.02	RUBBER, glazing	2	
8	JRC5142	NCA	GLASS, opening quarter light	2	clear
	JRC5143	£31.10	GLASS, opening quarter light	2	green tint
9	CZH3537	£98.20	FRAME, quarter light, RH	1	
	CZH3538	£98.20	FRAME, quarter light, LH	1	
10	PAM1019	£12.00	SEAL, opening quarter light	2	
	JRC2673	£12.20	SEAL, fixed quarter light	2	
	ALA5897	£7.80	SEAL, opening quarter light	2	Mkl
11	CZH1315	£30.50	GLASS, fixed quarter light	2	clear
12	14A7210	£32.40	SEAL, rear door windows	2	van & estate
13	14A7631	£9.50	CHANNEL, front	2	estate rear side windows
14	14A7630	£10.40	CHANNEL, rear	2	
15	14A7632	£22.30	CHANNEL, upper	2	
16	14A7633	£25.00	CHANNEL, lower	2	

Windscreen Tool

This is the best tool for fitting windscreens and insert strips. Supplied with a variety of hooks and eyes to allow easy fitting of the screen and rubber or plastic insert. Not suitable for metal inserts. Tech tip don't rush this job! Use a little washing up liquid to lubricate the tool and seals.

17	WBT001	NCA	WINDSCREEN INSERT FITTING TOOL	1	
----	--------	-----	--------------------------------	---	--

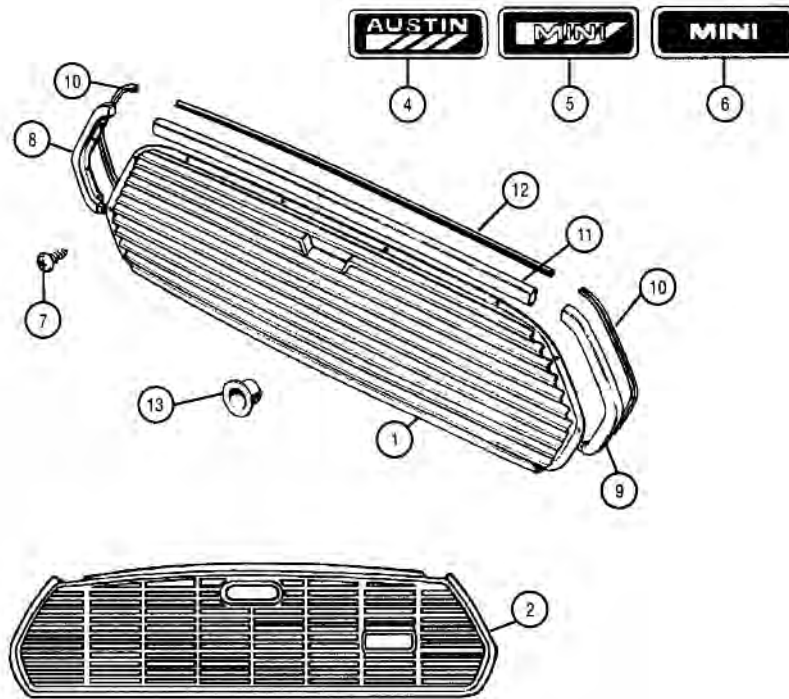

ill.	Part Number	Price £ea.	Description	Req.	Details
Front Grille & Fittings					
Note: Please see the Accessories section for our full range of grilles.					
1	24A2158	£78.00	GRILLE, stainless steel	1	Mkl Morris Cooper
	24A2159	£75.00	GRILLE, stainless steel (With full slats for internal bonnet release).	1	Mkl Morris Cooper
	14A7781FK	£6.00	MOUSTACHE KIT, complete	1	includes end mouldings
	14A7781	£90.00	MOUSTACHE	1	
	14A7782	£10.00	MOULDING, RH	1	for 14A7781
	14A7783	£10.00	MOULDING, LH	1	for 14A7781
	ADA3583	£0.60	CLIP	3/6	for left/right end mouldings
	24A198	£82.00	GRILLE	1	Austin Mkl Cooper and S
	14A7299	£86.00	GRILLE	1	Austin Mkl wavy grille
	ALA6654Z	£58.00	GRILLE, chrome	1	To 1977 & Mini 30
	HMP841003	£102.50	GRILLE KIT	1	inc: ALA6654Z and surrounds
	DHB10150PME	£60.00	GRILLE, black	1	1977-81
	CZH4015Z	NCA	GRILLE, black	1	1977-81
2	PAM1878	NCA	GRILLE, black with shield	1	1981-84
3	ALA6668	£63.70	GRILLE, chrome (External bonnet release).	1	Cooper Mkl
	ALA6669	£54.00	GRILLE, chrome (Internal bonnet release).	1	Cooper Mkl
	8B12502	£96.00	GRILLE (With 6in holes for spot lamp fitment, external bonnet release access).	1	Cooper Mkl stainless steel
	8B12503	£98.00	GRILLE, stainless steel (With 6in holes for spot lamp fitment, internal bonnet release).	1	Cooper Mkl

ill.	Part Number	Price £ea.	Description	Req.	Details	
	GAC8434X	£123.70	GRILLE KIT	1	inc: 8B12502 grille and lamps	
	GAC8420X	£123.70	GRILLE KIT	1	inc: 8B12503 grille and lamps	
	8B12504	£75.00	GRILLE, stainless steel (External bonnet release access).	1	Cooper Mkl	
	8B12505	£75.00	GRILLE, stainless steel (Internal bonnet release).	1	Cooper Mkl	
	8B12507	£82.00	GRILLE, stainless steel (External bonnet release access).	1	as Austin wavy Mkl	
	8B12508	£80.00	GRILLE, stainless steel (Internal bonnet release).	1	as Austin wavy Mkl	
	ALA6669	£54.00	GRILLE, Cooper	1	Cooper 1.3i	
	GAC8421X	£9.70	GRILLE BUTTON KIT	1		
	GAC8439X	£15.30	BONNET LOCK, black (Covers access to bonnet release).	1	fits externally	
	4	JRC7084	NCA	BADGE, grille, Austin	1	
	5	JPC9935	NCA	BADGE, grille, Mini	1	
	6	DAH10003	NCA	BADGE, grille, Mini	1	Mayfair and City
	7	AB608021	£0.17	SCREW, self tapping	4	top of grille to body
	7	AB606031	£0.32	SCREW, self tapping	8	side edges of grille to body
	8	ALA6508	£10.00	SURROUND, RH	1	
	9	ALA6509	£10.00	SURROUND, LH	1	Designer
	AB606028	£0.42	FIXING SCREW,	13	surrounds and top	
	10	37H8108M	£6.96	SEATING STRIP, chrome	1	per metre
	11	ALA6559	£17.00	FINISHER, grille top	1	
	11	ALA6559Z	£28.80	MOULDING TOP	1	
	12	24A2708	£21.70	SURROUND seating strip, 29"	2	
	13	ALA6747	NCA	PLUG, grille	2	
	HMP841009	£44.40	MOULDING KIT	1	inc: ALA6508/9/59	
	CZH3553	£25.90	SURROUND, headlamp, LH	1	GT and Clubman	

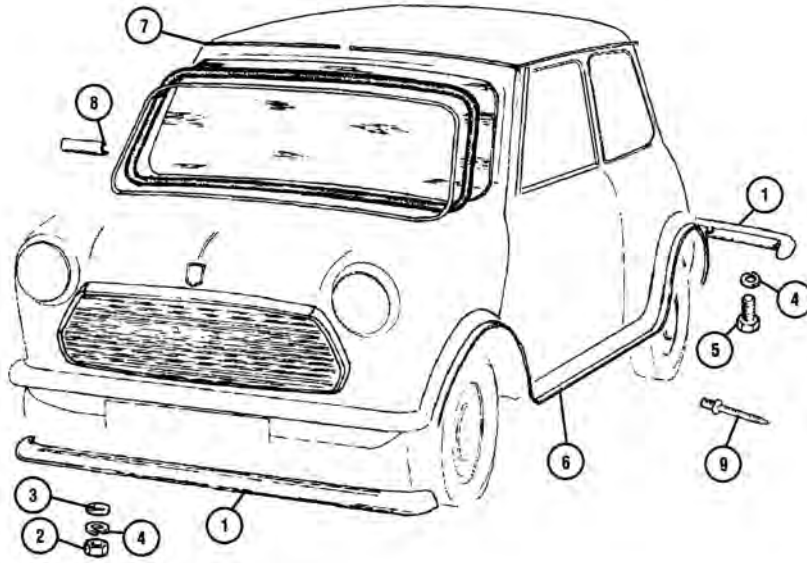

ill.	Part Number	Price £ea.	Description	Req.	Details
Bumpers & Fittings					
1	DPB10166Z	£38.00	BUMPER, stainless steel	2	aftermarket
	14A6779Z	£42.00	BUMPER, chrome	2	alternative
	14A6779SS	£53.20	BUMPER, stainless steel	2	
	14A9871	£70.00	BUMPER, stainless steel	2	with holes for corner bars
	EAM9219	£32.80	BUMPER, black	2	Clubman
	DPB10085PMG	£43.00	BUMPER, black	2	
	JRC8268Z	£43.00	BUMPER, nimbus	2	1984-88 and Mini 25
	CZH600Z	NCA	BUMPER, front	1	Clubman
	CZH605	NCA	BUMPER, rear	1	Clubman
	14A7550	£12.10	BUMPER, quarter, chrome	2	Mini van
	14A7550Z	NCA	BUMPER, quarter, chrome, aftermarket	2	Mini van
	EAM9248	£45.10	BUMPER, quarter, black	2	Mini van
2	GHF200	£0.19	NUT, plain, 1/4"	6	all bumpers
3	PWZ204	NCA	WASHER, plain, 1/4"	6	except EAM9219
	WC108051	£0.28	WASHER, plain, 5/16"	8	for bumper EAM9219
4	GHF331	£0.17	WASHER, spring, 1/4"	6	all except EAM9219
	GHF332	£0.28	WASHER, spring, 5/16"	8	for bumper
5	SH605051	£0.32	BOLT, bumper to body, 5/16"	8	EAM9219
	14A9923	£20.00	OVERRIDER	2	Mkl
	14A9924	£20.00	OVERRIDER	2	Mkl
	14A9877	£15.00	CORNER BAR, front, RH	1	
	14A9878	£15.00	CORNER BAR, front, LH	1	
	14A9919	£14.00	CORNER BAR, rear, RH	1	
	14A9920	£15.30	CORNER BAR, rear, LH	1	
	14A7598	£1.25	BRACKET	4	for fitment of overrider
	SH605101	£0.84	BOLT	4	for fitment of overrider
	37H9871M	£1.50	SEATING RUBBER	1	sold by the metre
	14A9879	£1.50	DISTANCE PIECE	4	bumper to corner bar
	GHF102	£0.42	BOLT	4	bumper to corner bar
	GHF117	£0.28	BOLT	4	overrider to corner bar
	WPA9006X	£310.00	OVERRIDER AND BUMPER KIT	1	(Kit includes 2 bumpers pre drilled 4 corner bars, 4 overriders and all fixings).
	14A8738SS	£20.00	OVERRIDER	4	Mkl plain overriders
	14A7598	£1.25	BRACKET	4	for fitment of overrider
	SH605101	£0.84	BOLT	4	for fitment of overrider
	37H9871M	£1.50	SEATING RUBBER	1	sold by the metre
	WPA9005X	£86.40	OVERRIDERS ONLY KIT	1	(Contains overriders and fixings, no corner bars).

ill.	Part Number	Price £ea.	Description	Req.	Details
	GAC9400X	£28.30	BRACKET, fog lamp relocation	1	required when fitting overriders and corner bars

Mouldings & Finishers

6	GZF105	£9.60	MOULDING, wheel arch, chrome	2	fluted
	GZF107	£6.00	MOULDING, wheel arch, chrome	2	flat
	GZF108M	£3.30	MOULDING, wheel arch, black	8	fluted, per metre

Note: Wheel arch extensions are available in sets, please see the Accessories section.

7	YGA1106	NCA	MOULDING, roof gutter, black, RH	1	
	YGA1107	NCA	MOULDING, roof gutter, black, LH	1	
	JRC8260LP	NCA	MOULDING, roof gutter, nimbus, RH	1	
	JRC8261LP	NCA	MOULDING, roof gutter, nimbus, LH	1	
	GAC8494X	£14.00	MOULDING, roof gutter, chrome	1	one piece chrome plastic
8	DBE10006PMD	£10.00	CLIP, roof moulding joint, black	2	
	DBE10006LMP	NCA	CLIP, roof moulding joint, nimbus	2	

Wheel Arch Extensions

	AJM1117Z	£29.00	ARCH KIT, black	1	
	CZH4312Z	£7.20	EXTENSION, wheel arch, black, RH	1	front
	CZH4313Z	£7.20	EXTENSION, wheel arch, black, LH	1	front
	CZH4314Z	£7.20	EXTENSION, wheel arch, black, RH	1	rear
	CZH4315Z	£7.20	EXTENSION, wheel arch, black, LH	1	rear
	CZH4316Z	£4.70	SILL FINISHER	2	

Note: Wheel arch extensions are also available in sets. See Accessories section for details.

	CZH4316	NCA	MOULDING, black	2	between arch extensions
9	DYQ100140	£2.00	RIVET, arch extension to body	a/r	
	DFJ100240LML	£121.00	EXTENSION, wheel arch (Important: see note*)	1	front, RH, sportspack Mini
	DFJ100250LML	£121.00	EXTENSION, wheel arch (Important: see note*)	1	front, LH, sportspack Mini
	DFK100460LML	£107.46	EXTENSION, wheel arch (Important: see note*)	1	rear, RH, sportspack Mini
	DFK100470LML	£107.46	EXTENSION, wheel arch (Important: see note*)	1	rear, LH, sportspack Mini
	GAC4606Z	NCA	SPORTSPACK ARCH KIT (Important: see note*)	1	complete set

*Note: As fitted to Rover sportspack Minis, made from rubber. They protrude 3.5". The metal arch require modification for fitment of 13" wheels).

	DDJ10002	£21.80	SILL FINISHER	2	rubber strip (Fits along the sill between the front and rear arch extensions).
	MRAC401	£77.50	ARCH KIT, Group 2	1	
	MRAC405	£115.00	ARCH KIT, Group 5	1	

ill.	Part Number	Price £ea.	Description	Req.	Details
Mudflaps					
	CAT10044	£43.30	MUDFLAPS, pair	1	Cooper logo
	AJM164	£41.40	MUDFLAPS, pair	1	Mini wording

ill.	Part Number	Price £ea.	Description	Req.	Details
Hub Caps					
	88G337Z	£32.00	HUB CAP, chrome	4	10" wheels

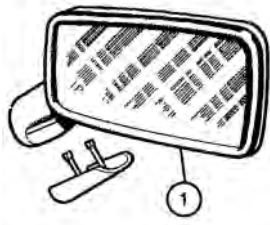

ill.	Part Number	Price £ea.	Description	Req.	Details
Door Mirrors					
1	JPC9848	£22.00	DOOR MIRROR, black plastic, RH	1	
	JPC9849	£22.00	DOOR MIRROR, black plastic, LH	1	
	CRB10184LML	£57.20	DOOR MIRROR, plastic, primed, RH	1	requires painting to suit body colour
	CRB10185LML	£67.60	DOOR MIRROR, plastic, primed, LH	1	

Note: These late type plastic door mirrors are available in black plastic or primed. Later models have the plastic door mirror painted in either white or body colour. Pre-painted mirrors are no longer available. Primed mirrors should be purchased and painted to suit your car.

GAM215A	£34.00	MIRROR, door, chrome, RH	1	convex glass
GAM216A	£34.00	MIRROR, door, chrome, LH	1	convex glass
GAM217X	£31.00	MIRROR, door, chrome, RH	1	flat glass
GAM218X	£31.00	MIRROR, door, chrome, LH	1	flat glass

Note: Please see Accessories section for our full range of mirrors.

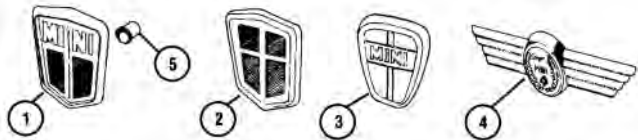

ill.	Part Number	Price £ea.	Description	Req.	Details
Badges					
	24A71	£11.20	BADGE, bonnet	1	Austin Cooper and S Mkl
	24A72	£28.00	BADGE, bonnet	1	Morris Cooper and S Mkl
	ADA3580	£40.00	BADGE, bonnet	1	Morris Mini Mkl
	24G1201	£11.70	BADGE INSERT, bonnet	1	Austin Mkl
	14A6837	£21.00	BADGE SURROUND, bonnet	1	Austin insert surround
	14A6802	£12.10	BADGE, boot	1	Austin script Mkl
	24A23	£8.20	BADGE, boot	1	Cooper script Mkl
	24A997	£8.75	BADGE, boot	1	Mini script
	14A6853	£8.50	BADGE, boot	1	Seven script
	24A1401	£9.20	BADGE, boot, small	1	S script
	24A1402	£9.20	BADGE, boot, large	1	S script
	24A24	£35.00	BADGE, boot	1	Morris Cooper script
	ADA3730	£18.00	BADGE, boot	1	Mini Minor script
	ALA6622	£13.00	BADGE, boot	1	Austin Mini script
	ALA6694	£7.50	BADGE, boot	1	850 script
	ALA6695	£15.00	BADGE, boot	1	1000 script
	ALA6696	£12.40	BADGE, boot	1	1275 script
	ALA6519	£10.50	BADGE SURROUND, bonnet	1	Cooper S Mkl
	ALA6514	£12.60	BADGE INSERT, bonnet	1	Austin Cooper S Mkl
	ALA6515	£13.00	BADGE INSERT, bonnet	1	Morris Cooper S Mkl
	ALA6542	£16.00	BADGE SURROUND, boot	1	Cooper S Mkl
	ALA6513	£14.50	BADGE INSERT, bonnet	1	Austin Cooper Mkl
	ALA6517	£20.00	BADGE SURROUND, bonnet	1	Austin Cooper Mkl
	ALA6511	NCA	BADGE INSERT, bonnet	1	Morris Cooper Mkl
	ALA6518	£20.00	BADGE SURROUND, bonnet	1	Morris Cooper Mkl

ill.	Part Number	Price £ea.	Description	Req.	Details
	ALA6536	£13.20	BADGE INSERT, boot	1	Cooper S Mkl
	ALA6537	£17.50	BADGE INSERT, boot	1	Morris Cooper Mkl
	ALA6538	£12.10	BADGE INSERT, boot	1	Austin Cooper Mkl
	AVB192	£4.20	BADGE	1	Mkl script
	CZH1220	£16.30	BADGE, front grille	1	Clubman GT red
	CZH4016	£15.00	BADGE, boot	1	Mini Special
	CZH1269	£15.30	BADGE, boot	1	1275 GT
	CZH4154	£15.30	BADGE, boot	1	1275 GT late
	CZH4154F	£4.20	BADGE FOIL, boot badge	1	1275 GT late
	CZH1220	£16.30	BADGE, boot	1	GT, red
	CZH1381	£15.30	BADGE, boot	1	Mkl Cooper S
1	CZH4378	£33.00	BADGE, bonnet	1	To VIN 349159
	CZH1305	£21.50	BADGE, bonnet	1	blue on silver
2	KPC1002	£19.80	BADGE, bonnet	1	VIN349160 To 463576
3	DAB10076	£34.20	BADGE, bonnet	1	VIN 463577 To 493180
4	DAH10036	£14.00	BADGE, bonnet	1	Cooper models
	DAB101130	NCA	BADGE, bonnet	1	Italian job
	DAB10038	£26.40	BADGE, bonnet	1	Checkmate
	DAB10085	NCA	BADGE, bonnet	1	Rover
	DAH100410	NCA	BADGE, boot	1	'Mini' in white as Italian Job
	DAH100590MMM	£15.00	BADGE, boot, self adhesive	1	1997-On Mini winged badge
5	GHF1531	£0.28	LIP, badge retaining	3	



ill.	Part Number	Price £ea.	Description	Req.	Details
Decals					
	DAE10119NMN	£43.90	COACHLINE, white	1	
	JRC2679NMN	NCA	COACHLINE, white	1	
	DAE10119PMA	NCA	COACHLINE, black	1	
	DAF10380NMN	£6.50	COOPER LAUREL, white	1	
1	DAF10380PMA	£5.90	COOPER LAUREL, black	1	
	DAF10402NMN	£42.40	BONNET STRIPE, white, RH	1	
	DAF10403NMN	£42.40	BONNET STRIPE, white, LH	1	
	DAF10402PMA	NCA	BONNET STRIPE, black, RH	1	
	DAF10403PMA	£42.40	BONNET STRIPE, black, LH	1	
	DAF104090RHR	NCA	BOOT DECAL	1	Italian Job for white cars
	DAF104090RHS	£14.90	BOOT DECAL	1	Italian Job for green, red or black cars
	DAF104520RAU	£32.30	BOOT DECAL	1	Monte Carlo
	DAF104530RAU	NCA	BODY SIDE DECAL	1	Monte Carlo
	DAF104540RAU	£22.60	BONNET DECAL	1	Monte Carlo
	DAF105120	£77.90	ROOF DECAL	1	Union flag

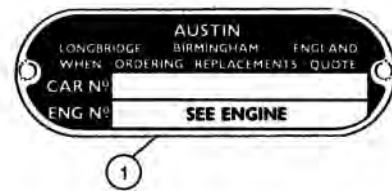

ill.	Part Number	Price £ea.	Description	Req.	Details
Chassis Plates					
1	CRCP314	£5.10	CHASSIS PLATE, Austin	1	not stamped
	CRCP316	£4.50	CHASSIS PLATE, Morris	1	not stamped

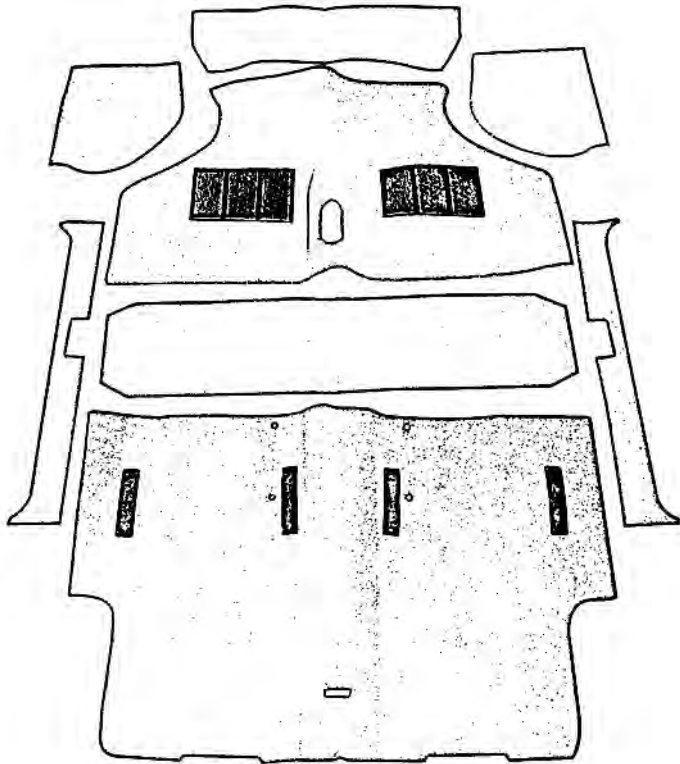

ill. Part Number Price £ea. Description Req. Details

Carpet Sets

Minis can get very noisy when driving at speed, our carpet sets are made with this in mind. The front sections of carpet feature 12mm thick sections of sound deadening laminated to the carpet backing to keep the sound levels as low as possible. Carpet set includes all fittings.

CSA9000X	£214.20	CARPET SET, black	1
CSR9000X	£209.40	CARPET SET, red	1
CSF9000X	£214.20	CARPET SET, grey	1

These moulded carpet sets are produced by the original manufacturer. They do not have sound deadening backing material, however, we offer a sound deadening kit made of the same material as fitted to the carpet sets listed above. See Sound Insulation listed below.

CSA9002X	£214.20	CARPET SET, black	1	To 1973
CSA9002Z	£40.00	CARPET SET, black	1	} budget type, } beaded edge
CSF9002X	£214.20	CARPET SET, grey	1	To 1973
CSF9002Z	£70.00	CARPET SET, grey	1	} budget type, } beaded edge
CSN9001Z	£43.70	CARPET SET, blue	1	} budget type, } beaded edge
CSR9002X	£209.40	CARPET SET, red	1	To 1973
CSR9002Z	£40.00	CARPET SET, red	1	} budget type, } beaded edge
610624	£0.56	FASTENER, fitted to floor	4	
GHF600	£0.13	RIVET, for 610624	4	
2H8445	£0.37	CLIP, carpet to floor	4	
14G8736	£0.28	RING, spiked, through carpet	4	

Sound Insulation Kits

Keeping the volume of noise in your Mini down to a minimum can be a problem, any of the products listed below should help to solve the problem.

GAC8417X	£52.70	INSULATION KIT, engine bay	1	bonnet & bulkhead
GAC8429X	£56.20	INSULATION KIT, interior	1	under carpet

Boot Floor Kit

Tidy the boot space with one of these carpeted wood false floor kits. Installed it provides a flat floor tidying the boot area and helping to protect the battery and spare wheel.

BFK9001X	£98.60	FLOOR KIT, 5.5 gallon	1	1974-79
BFK9002X	£98.60	FLOOR KIT, 7.5 gallon	1	1980-On
BFK9004X	£127.30	BRACKET SET, boot floor	1	165 section tyres

ill. Part Number Price £ea. Description Req. Details

Dash Panel Kits

DPK9000X	£53.00	DASH PANEL KIT, centre speedo	1	speedo only
DPK9001X	£53.00	DASH PANEL KIT, centre binnacle	1	3 gauge no vents
DPK9002X	£53.00	DASH PANEL KIT, centre binnacle	1	3 gauge with vents
DPK9003X	£81.60	DASH PANEL KIT, offset binnacle	1	2 & 3 gauge, RHD
DPK9004X	£81.60	DASH PANEL KIT, offset binnacle	1	2 & 3 gauge, LHD

Trim Panel Kits

Enhance the interior of your Mini, available in Black, Red or Nimbus (grey). These high quality trim panel kits feature a horizontal seam welded design styled on the original Cooper trim design.

TKF9000X	£395.90	TRIM PANEL KIT, deluxe, grey	1	Mkl & II
TKF9008X	£428.00	TRIM PANEL KIT, standard, grey	1	Mkl & II
TKR9000X	£395.90	TRIM PANEL KIT, deluxe, red	1	Mkl & II
TKA9008X	£428.00	TRIM PANEL KIT, standard, black	1	Mkl & II
TKA9042X	£249.30	TRIM PANEL KIT, black	1	MkIII On
TKR9042X	£249.30	TRIM PANEL KIT, red	1	MkIII On
TKF9042X	£249.30	TRIM PANEL KIT, grey	1	MkIII On
GHF1222	£0.37	CLIP, trim panel to door	a/r	MkIII On
YGA452	£17.30	POCKET, door, plastic	2	MkIII On

Headlining & Sun Visors

Our headlinings feature a ready stitched vinyl replacement main section with all loops stitched in place. The kit also contains a pair of rear pillar covers in matching material.

HLK3000C	£117.40	HEADLINING KIT, cream crackle	1	Mkl
		(Inc: Both rear C post material panels, shape rods not included).		
PAM5401LNG	£209.20	HEADLINING KIT, grey	1	MkIII On
		(Inc: Both rear C post material panels, shape rods not included).		
HLK3012P	£117.40	HEADLINING KIT, light grey	1	
HLK3012W	£117.40	HEADLINING KIT, white	1	
EEB100060	£15.00	HEADLINING RAIL	1	number 1
EEB100070	£15.00	HEADLINING RAIL	2	number 2 and 3
EEB100080	£15.00	HEADLINING RAIL	1	number 4
EEB100090	£17.20	HEADLINING RAIL	1	number 5
EEB100100	£15.00	HEADLINING RAIL	1	number 6
YGX4173LNG	NCA	SUN VISOR, light grey	1	
GAC8465X	£36.00	VISOR, black	1	no mirror
GAC8466X	£39.10	VISOR, black	1	with mirror

Parcel Shelf Kits

DPK9010X	£52.00	DASH LINER KIT, parcel shelf	1	central binnacle
DPK9010CARDS	£20.30	DASH LINER SUPPORTS	1	

Trim Adhesive

UBS110	£15.00	ADHESIVE, 0.5 litre	a/r
UBS203	£8.30	ADHESIVE, 370g aerosol	a/r

Miscellaneous

EET11Z	£12.30	AERIAL, stainless steel	1	
GAC7999X	£11.65	HEADLAMP EYEBROWS, chrome	1	pair
KRH10003	£71.40	SUMPGUARD, Cooper	1	
EBF100150	£64.00	LOAD LINER, boot	1	
24A1169	£13.70	FINISHER, rear pocket	2	Mkl & II
24A1538	£15.00	ASHTRAY, flat lid	1	
8D2490	£15.00	ASHTRAY, slotted lid	1	
MT9301	£9.00	AIR VENT COVERS, chrome	1	
		(Includes vent surrounds and adjuster knob covers).		
105-467	NCA	CARBON FIBRE SHEET	1	
GAC8418X	£53.00	TOOL BAG, black hardura	1	
GAC8419X	£41.60	JACK BAG, black hardura	1	

Hardware and Fixings

Following is a listing of the common fasteners used on BL cars. These fasteners are for general use and are not intended to replace those listed for specific applications elsewhere in this catalogue.

To aid identification by terminology, a screw is threaded for its full length. A bolt is only part threaded with a plain unthreaded shank area between the head and the thread. The part number two letter prefix of SH means that the item is a Screw with a Hexagon head. The prefix BH means a Bolt with a Hexagon head. The first number defines the thread type, UNF = 6, UNC = 5. The second and third numbers give the thread diameter in increments of 1/16", e.g. 04 = 1/4", 05 = 5/16", 10 = 5/8". The fourth and fifth digits show the length in increments of 1/8", e.g. 04 = 1/2", 16 = 2", 23 = 2 7/8". The last digit defines finish, 1 = zinc plated. This coding system is only applicable to bolts and screws; nuts & washers are coded by a similar system that follows some of the above principles.

3/16" UNF Bolts & Set Screws

Hexagon Headed 3/8" A.F. Spanner Size

Bolt	Length	Set Screw
N/A	3/8"	HU503
N/A	1/2"	HU504
N/A	5/8"	HU505
N/A	3/4"	HU506
N/A	7/8"	HU507
N/A	1"	HU508

1/4" UNF Bolts & Set Screws

Hexagon Headed 7/16" A.F. Spanner Size

Bolt	Length	Set Screw
N/A	3/8"	SH604031
N/A	1/2"	SH604041
N/A	5/8"	SH604051
N/A	3/4"	SH604061
N/A	7/8"	SH604071
BH604081	1"	SH604081
BH604091	1 1/8"	SH604091
BH604101	1 1/4"	SH604101
BH604111	1 3/8"	SH604111
BH604121	1 1/2"	SH604121
BH604141	1 3/4"	SH604141
BH604161	2"	SH604161
BH604181	2 1/4"	N/A
BH604201	2 1/2"	N/A
BH604241	3"	N/A

5/16" UNF Bolts & Set Screws

Hexagon Headed 1/2" A.F. Spanner Size

Bolt	Length	Set Screw
N/A	3/8"	SH605031
N/A	1/2"	SH605041
N/A	5/8"	SH605051
N/A	3/4"	SH605061
N/A	7/8"	SH605071
N/A	1"	SH605081
BH605091	1 1/8"	SH605091
BH605101	1 1/4"	SH605101
BH605111	1 3/8"	SH605111
BH605121	1 1/2"	SH605121
BH605141	1 3/4"	SH605141
BH605151	1 7/8"	SH605151
BH605161	2"	SH605161
BH605181	2 1/4"	SH605181
BH605201	2 1/2"	SH605201
BH605221	2 3/4"	SH605221
BH605241	3"	SH605241

3/8" UNF Bolts & Set Screws

Hexagon Headed 9/16" A.F. Spanner Size

Bolt	Length	Set Screw
N/A	3/8"	SH606031

N/A	1/2"	SH606041
N/A	5/8"	SH606051
N/A	3/4"	SH606061
N/A	7/8"	SH606071
BH606081	1"	SH606081
BH606091	1 1/8"	SH606091
BH606101	1 1/4"	SH606101

3/8" UNF Bolts & Set Screws

Hexagon Headed 9/16" A.F. Spanner Size

Bolt	Length	Set Screw
BH606111	1 3/8"	SH606111
BH606121	1 1/2"	SH606121
BH606141	1 3/4"	SH606141
BH606161	2"	SH606161
BH606181	2 1/4"	SH606181
BH606201	2 1/2"	SH606201
BH606221	2 3/4"	N/A
BH606241	3"	N/A
BH606281	3 1/2"	N/A
BH606321	4"	N/A

7/16" UNF Bolts & Set Screws

Hexagon Headed 5/8" A.F. Spanner Size

Bolt	Length	Set Screw
N/A	5/8"	SH607051
N/A	3/4"	SH607061
N/A	7/8"	SH607071
N/A	1"	SH607081
N/A	1 1/8"	SH607091
N/A	1 1/4"	SH607101
N/A	1 3/8"	SH607111
BH607121	1 1/2"	SH607121
BH607141	1 3/4"	SH607141
BH607161	2"	SH607161
BH607181	2 1/4"	SH607181
BH607201	2 1/2"	N/A
BH607241	3"	BH607241

1/2" UNF Bolts & Set Screws

Hexagon Headed 3/4" A.F. Spanner Size

Bolt	Length	Set Screw
N/A	1/2"	SH608041
N/A	5/8"	SH608051
N/A	1"	SH608081
N/A	1 1/2"	SH608121
N/A	1 3/4"	SH608141
BH608141	1 3/4"	SH608141
BH608161	2"	N/A
BH608181	2 1/4"	N/A
BH608201	2 1/2"	SH608201
BH608241	3"	N/A

1/4" UNC Bolts & Set Screws

Hexagon Headed 7/16" A.F. Spanner Size

Bolt	Length	Set Screw
N/A	3/8"	SH504031
N/A	1/2"	SH504041
N/A	5/8"	SH504051
N/A	3/4"	SH504061
N/A	7/8"	SH504071
N/A	1"	SH504081
BH504091	1 1/8"	SH504091
N/A	1 1/4"	SH504101
BH504111	1 3/8"	SH504111
BH504121	1 1/2"	SH504121
N/A	1 3/4"	SH504141
BH504161	2"	N/A
BH504181	2 1/4"	SH504181
BH504201	2 1/2"	N/A

5/16" UNC Bolts & Set Screws

Hexagon Headed 1/2" A.F. Spanner Size

Bolt	Length	Set Screw
N/A	3/8"	SH505031
N/A	1/2"	SH505041
N/A	5/8"	SH505051
N/A	3/4"	SH505061
N/A	7/8"	SH505071
N/A	1"	SH505081
N/A	1 1/8"	SH505091

BH505101	1 1/4"	SH505101
BH505111	1 3/8"	SH505111
BH505121	1 1/2"	SH505121
BH505141	1 3/4"	SH505141
BH505161	2"	N/A
BH505181	2 1/4"	N/A
BH505201	2 1/2"	SH505201
BH505241	3"	N/A

3/8" UNC Bolts & Set Screws

Hexagon Headed 9/16" A.F. Spanner Size

Bolt	Length	Set Screw
N/A	1/2"	SH506041
N/A	3/4"	SH506061
N/A	7/8"	SH506071
BH506081	1"	SH506081
N/A	1 1/8"	SH506091
N/A	1 1/4"	SH506101
BH506111	1 3/8"	SH506111
BH506121	1 1/2"	SH506121
BH506141	1 3/4"	N/A
BH506161	2"	SH506161
BH506181	2 1/4"	N/A
BH506201	2 1/2"	N/A
BH506241	3"	SH506241

Self Tapping Screws

Pan Head	Size	Length	Countersunk Head
AB604021	No.4	1/4"	AC604021
AB606021	No.6	1/4"	N/A
AB606031	No.6	3/8"	N/A
AB606041	No.6	1/2"	AC606041
AB606061	No.6	3/4"	AC606061
AB606081	No.6	1"	AC606081
AB608041	No.8	1/2"	AC608041
AB608061	No.8	3/4"	AC608061
AB608081	No.8	1"	N/A
AB610041	No.10	1/2"	AC610041
AB610061	No.10	3/4"	AC610061
AB610081	No.10	1"	AC610081
AB612041	No.12	1/2"	AC612041
AB612061	No.12	3/4"	N/A
AB612081	No.12	1"	AC612081
AB614061	No.14	3/4"	N/A
AB614081	No.14	1"	AC614081

- B** = Pan Head
- C** = Countersunk Head
- 1st digit** = thread type (coarse or fine)
- 2nd/3rd digit** = diameter
- 4th/5th** = length in 1/8" increments
- 6th** = finish (1 = zinc plated)

Cross Slot Screws

Pan Head	Size	Length	Countersunk Head
PMZ204	No.6 UNC	1/4"	CMZ204
PMZ208	No.6 UNC	1/2"	N/A
PMZ304	No.10 UNF	1/4"	N/A
PMZ305	No.10 UNF	5/16"	CMZ305
PMZ306	No.10 UNF	3/8"	CMZ306
PMZ307	No.10 UNF	7/16"	CMZ307
PMZ308	No.10 UNF	1/2"	CMZ308
PMZ310	No.10 UNF	5/8"	CMZ310
PMZ312	No.10 UNF	3/4"	CMZ312
PMZ314	No.10 UNF	7/8"	N/A
PMZ316	No.10 UNF	1"	CMZ316
SE604041	1/4" UNF	1/2"	SF604041
SE604051	1/4" UNF	5/8"	SF604051
SE604061	1/4" UNF	3/4"	SF604061
N/A	1/4" UNF	7/8"	SF604071
SE604081	1/4" UNF	1"	SF604081
SE604121	1/4" UNF	1 1/2"	SF604121
SE605061	5/16" UNF	3/4"	SF605061
SE605081	5/16" UNF	1"	SF605081

Plain Nuts

Full Nut	Thread Size	Spanner Size	Half Nut
HN2003	No. 6 UNF	5/16"	N/A

HN2005	3/16" UNF	3/8"	N/A
GHF206	3/16" UNF	5/16"	N/A
HN2007	1/4" UNF	7/16"	JN2107
HN2008	5/16" UNF	1/2"	JN2108
HN2009	3/8" UNF	9/16"	JN2109
HN2010	7/16" UNF	5/8"	JN2110
HN2011	1/2" UNF	3/4"	JN2111
HN2012	9/16" UNF	7/8"	JN2112
N/A	5/8" UNF	15/16"	JN2113
HN2057	1/4" UNC	7/16"	JN2157
HN2058	5/16" UNC	1/2"	JN2158
HN2059	3/8" UNC	9/16"	JN2159

Nyloc Self Locking Nuts

Full Nut	Thread Size	Spanner Size	Half Nut
YN2905	3/16" UNF	5/16"	N/A
YN2907	1/4" UNF	7/16"	GHF271
YN2908	5/16" UNF	1/2"	TN3208
YN2909	3/8" UNF	9/16"	TN3209
YN2910	7/16" UNF	5/8"	TN3210
YN2911	1/2" UNF	3/4"	TN3211
YN2912	9/16" UNF	7/8"	TN3212
YN2913	5/8" UNF	15/16"	TN3213

'Aero' Or All Metal, 'Phillidas' Self Locking Nuts

Full Nut	Thread Size	Spanner Size	Half Nut
AN3507	1/4" UNF	7/16"	N/A
AN3508	5/16" UNF	1/2"	N/A
AN3509	3/8" UNF	9/16"	N/A
AN3510	7/16" UNF	5/8"	N/A
AN3511	1/2" UNF	3/4"	N/A

Slotted Nuts

Full Nut	Thread Size	Spanner Size	Half Nut
ND606041	3/8" UNF	9/16"	LN2209
ND607041	7/16" UNF	5/8"	NL607041
ND608041	1/2" UNF	3/4"	LN2211
ND609041	9/16" UNF	7/8"	LN2212
ND610041	5/8" UNF	15/16"	NL610041

Plain Brass - Manifold Nuts

Full Nut	Thread Size	Spanner Size
GHF261	5/16" UNF	1/2"
GHF262	3/8" UNF	9/16"
GHF270	5/16" UNC	1/2"
GHF269	3/8" UNC	9/16"

Spring/Spire Nut

Flat Type	Screw Size	'U' Type
GHF700	No. 6	GHF711
GHF701	No. 8	GHF712
GHF702	No. 10	GHF713
GHF703	No. 12	GHF714
GHF704	No. 14	N/A

Captive Nuts

Captive nuts consist of a square nut and cage which we supply individually as required. Always match nut and cage A.F. sizes.

Part Number	Description	Thread Size
NQ2707	Nut, 7/16" AF	1/4"
NQ2708	Nut, 5/8" AF	5/16"
CN4	Nut, fits CN3 cage	1/4"
CN5	Nut, /2" AF	5/16"

Part Number	Description	Spanner Size (AF)
CN2	Cage, square	7/16"
CN3	Cage, oblong	7/16"
600032	Cage, square	1/2"

Shake-Proof Washers

Internal Star	Hole Size	External Star
WF704061	No. 6	WE704061
WF702101	3/16"	WE702101
WF600041	1/4"	WE600041
WF600051	5/16"	WE600051
WF600061	3/8"	WE600061
WF600071	7/16"	WE600071
WF600081	1/2"	WE600081
WF600091	9/16"	WE600091
WF600101	5/8"	WE600101

Spring Type Locking Washers

Single Coil	Hole Size	Double Coil
WL700061	No. 6	N/A
WL700081	No. 8	N/A
WL700101	3/16"	AJD7721
GHF331	1/4"	AJD7722
GHF332	5/16"	AJD7731
GHF333	3/8"	AJD7742
GHF334	7/16"	N/A
GHF335	1/2"	N/A
GHF336	5/8"	N/A

Plain Washers

Standard Type	Hole Size	Repair Type
N/A	No. 6	WP3
N/A	No. 8	WP4
GHF306	3/16"	WP5
GHF300	1/4"	WP120
GHF301	5/16"	WP105
GHF302	3/8"	WP130
GHF303	7/16"	WM69
GHF304	1/2"	N/A
N/A	9/16"	WP12
N/A	5/8"	WPZ110

Sealing Washers

Fibre Washer	Hole Size	Copper Washer
WF505	3/16"	N/A
GHF342	1/4"	GHF361
GHF343	5/16"	GHF362
GHF344	3/8"	GHF363
GHF345	7/16"	GHF364
GHF346	1/2"	GHF365
GHF347	9/16"	N/A
GHF348	5/8"	N/A

Studs

A stud is a length of round bar threaded at both ends. The length of thread at each end of the stud may vary for specific applications.

Note: The following studs have fine (UNF) threads at one end and course (UNC) at the other.

Part Number	Diameter	Overall Length
TE504081	1/4"	1"
TE504131	1/4"	1 5/8"
53K2171	5/16"	1 1/8"
TE505111	5/16"	1 3/8"
TE505121	5/16"	1 1/2"
TE505131	5/16"	1 5/8"
TE505141	5/16"	1 3/4"
TE505151	5/16"	1 7/8"
TE505161	5/16"	2"
TE505181	5/16"	2 1/4"
TE505201	5/16"	2 1/2"
TE505221	5/16"	2 3/4"
TE505241	5/16"	3"
TE505261	5/16"	3 1/4"
TE505271	5/16"	3 3/8"
TE505281	5/16"	3 1/2"
TE505341	5/16"	4 1/4"
TE506101	3/8"	1 5/16"
TE506131	3/8"	1 5/8"
TE506141	3/8"	1 3/4"

TE506161	3/8"	2"
TE506201	3/8"	2 1/2"
TE506361	3/8"	3 1/2"

Note: The following list is of studs have fine (UNF) threads at both ends.

Part Number	Diameter	Overall Length
TE604081	1/4"	1"
TE604091	1/4"	1 1/8"
TE604101	1/4"	1 1/4"
TE605101	5/16"	1 1/4"
TE605111	5/16"	1 3/8"
TE605121	5/16"	1 1/2"
TE605131	5/16"	1 5/8"
TE605141	5/16"	1 3/4"
TE605151	5/16"	1 7/8"
TE605181	5/16"	2 1/4"
TE605201	5/16"	2 1/2"
TE605221	5/16"	2 3/4"
TE605251	5/16"	3 1/8"
TE605291	5/16"	3 5/8"
TE606101	3/8"	1 1/4"
TE606111	3/8"	1 3/8"
TE606121	3/8"	1 1/2"
TE606141	3/8"	1 3/4"
TE606151	3/8"	1 7/8"

Note: The following studs have course (UNC) threads at both ends.

Part Number	Diameter	Overall Length
101442	3/8"	1 5/8"
058688	3/8"	1 11/16"
115696	3/8"	1 13/16"
058917	3/8"	1 15/16"
102474	3/8"	2 1/16"
107055	3/8"	2 3/8"

Dowels

Part Number	Diameter	Overall Length
DP204	1/8"	1/4"
DP205	1/8"	5/16"
DP306	3/16"	3/8"
DP407	1/4"	7/16"
DP408	1/4"	1/2"
DP410	1/4"	5/8"
DP411	1/4"	11/16"
DP414	1/4"	7/8"
DP508	5/16"	1/2"
DP514	5/16"	7/8"
DP608	3/8"	1/2"
DP610	3/8"	5/8"
DP610	3/8"	1 3/16"

Clevis Pins

(Measured from under head to end)

Part Number	Length	Diameter
108326	1/2"	1/8"
PJ8504	3/8"	3/16"
CLZ307	7/16"	3/16"
CLZ308	1/2"	3/16"
CLZ309	9/16"	3/16"
CLZ310	5/8"	3/16"
CLZ311	11/16"	3/16"
CLZ312	3/4"	3/16"
CLZ313	13/16"	3/16"
CLZ314	7/8"	3/16"
CLZ315	15/16"	3/16"
CLZ316	1"	3/16"
CLZ317	1 1/16"	3/16"
N/A	3/8"	1/4"
N/A	7/16"	1/4"
CLZ408	1/2"	1/4"
CLZ409	9/16"	1/4"
CLZ410	5/8"	1/4"
CLZ411	11/16"	1/4"
CLZ412	3/4"	1/4"
CLZ413	13/16"	1/4"
CLZ414	7/8"	1/4"

CLZ415	15/16"	1/4"
CLZ416	1"	1/4"
CLZ417	1 1/16"	1/4"
CLZ427	1 11/16"	1/4"
N/A	1/2"	5/16"
N/A	9/16"	5/16"
CLZ510	5/8"	5/16"
CLZ511	11/16"	5/16"
CLZ512	3/4"	5/16"
CLZ513	13/16"	5/16"
CLZ514	7/8"	5/16"
CLZ515	15/16"	5/16"
CLZ516	1"	5/16"
CLZ517	1 1/16"	5/16"
CLZ518	1 1/8"	5/16"

Split Pins

Part Number	Length	Diameter
GHF500	1 1/2"	1/16"
GHF501	1 1/2"	5/64"
GHF502	1 1/2"	3/32"
GHF503	2 1/4"	7/64"
GHF504	2 1/4"	1/8"
GHF505	2 1/4"	9/64"
GHF506	2 1/4"	5/32"

Brake & Fuel Pipe

(Supplied in 25 foot rolls)

Part Number	Material	Diameter
MPKF125	Cupro-nickel	3/16"
MPKF225	Cupro-nickel	1/4"
MPKF325	Cupro-nickel	5/16"
EF125	Steel	3/16"
EF225	Steel	1/4"
EF325	Steel	5/16"

Grease Nipples

Part Number	Thread Size	Angle
UHN400	1/8" BSP	straight, short
UHN445	1/8" BSP	45° angle
LN30041	1/8" BSP	90° angle
144825	1/8" BSP	straight, long
056935	1/4" BSP	straight
125361	1/4" BSP	45° angle
056934	1/4" BSP	90° angle

Pipe Nuts - Male, Steel

Part Number	Thread Size	Pipe Bore
TM606031	3/8" UNF	3/16"
TM110051	10mm x 1mm	3/16"
LK21994	3/8" BSF	3/16"
BCA4370	7/16" UNF	1/4"
BHA4706	7/16" UNF	3/16"
AUSU40A	1/2" UNF	5/16"

Pipe Nuts - Male, Brass

Part Number	Thread Size	Pipe Bore
AEHU1	3/8" UNF	3/16"
AEHU2	10mm x 1mm	3/16"
AEHU3	3/8" BSF	3/16"
AEHU7	7/16" UNF	3/16"

Pipe Nuts - Female, Steel

Part Number	Thread Size	Pipe Bore
AEHU1A	3/8" UNF	3/16"
SU2A	10mm x 1mm	3/16"
SU4A	7/16" UNF	1/4"
HU41A	1/2" UNF	5/16"

Pipe Nuts - Female, Brass

Part Number	Thread Size	Pipe Bore
AEHU1A	3/8" UNF	3/16"
AEHU2A	10mm x 1mm	3/16"
AEHU4A	7/16" UNF	1/4"

Bleed Screws

Part Number	Thread Size
556508A	3/8" UNF
608400A	10mm metric
27H7166	3/8" BSF

Pipe Clips

Part Number	Capacity
GHF1191	SINGLE, 3/16"
GHF1192	SINGLE, 1/4"
624155	DOUBLE, 3/16"

Petrol Pipe Clips (Metric) ('Enots' Type)

Part Number	To Suit Diameter
GGT1108X	8mm
GGT1109X	9mm
GGT1110X	10mm
GGT1111X	11mm
GGT1112X	12mm
GGT1113X	13mm
GGT1114X	14mm
GGT1115X	15mm
GGT1116X	16mm
GGT1117X	17mm

Hose Clips ('Jubilee' Type) Mild Steel (Imperial)

Part Number	To Suit Diameter
GHC304	3/8" - 1/2"
GHC405	7/16" - 5/8"
GHC11020	1/2" - 3/4"
GHC11022	5/8" - 7/8"
GHC11025	3/4" - 1"
GHC11030	5/8" - 1 1/8"
GHC811	1" - 1 3/8"
GHC11035	1 1/8" - 1 5/8"
GHC1015	1 3/8" - 2"
GHC1217	1 1/2" - 2 1/4"
GHC1622	2" - 2 3/4"
GHC2228	2 3/4" - 3 1/2"
GHC2632	3 1/4" - 4"
GHC3036	3 3/4" - 4 1/2"
GHC3340	4 1/8" - 5"

Hose Clips ('Jubilee' Type) Stainless Steel (Metric)

Part Number	To Suit Diameter
GHC10408	8 - 12 mm
GHC10410	12 - 18 mm
GHC10411	8 - 16 mm
GHC10412	12 - 20 mm
GHC10413	16 - 25 mm
GHC11030	20 - 32 mm
GHC11035	25 - 40 mm
GHC10416	32 - 50 mm
GHC10417	46 - 60 mm
GHC10418	50 - 70 mm
GHC10419	60 - 80 mm
GHC10420	70 - 90 mm
GHC10421	80 - 100 mm

Hose Clips ('Supergrip' Type) (With Single Slotted Hexagon Head)

Part Number	To Suit Diameters
CS4009	7/16" - 9/16"
CS4011	1/2" - 11/16"
CS4012	9/16" - 3/4"
CS4013	5/8" - 13/16"
CS4014	11/16" - 7/8"
CS4016	3/4" - 1"
CS4017	13/16" - 1 1/16"
CS4018	7/8" - 1 1/8"
CS4020	1" - 1 1/4"
CS4022	1 1/8" - 1 3/8"
CS4023	1 1/4" - 1 7/16"
CS4024	1 5/16" - 1 1/2"
CS4025	1 3/8" - 1 9/16"
CS4026	1 7/16" - 1 5/8"

CS4028	1 9/16" - 1 3/4"
CS4029	1 5/8" - 1 13/16"
CS4030	1 11/16" - 1 7/8"
CS4032	1 7/8" - 2"
CS4034	1 15/16" - 2 1/8"
CS4036	2 1/16" - 2 1/4"
CS4037	2 1/8" - 2 5/16"
CS4038	2 3/16" - 2 7/16"
CS4039	2 1/4" - 2 7/16"
CS4040	2 5/16" - 2 1/2"
CS4041	2 3/8" - 2 9/16"
CS4042	2 7/16" - 2 5/8"
CS4048	2 13/16" - 3"
CS4052	3 1/16" - 3 1/4"

Note: Original "Supergrip" clips were supplied with a single slotted round-head screw. The modern replacement comes with a hexagon headed screw. For the authentic look we have resourced the original type screw, (sold separately).

CS4099 (Round-Head Screw).

'P' Clips - Imperial

Part Number	Cable Diameter	Hole Size
PCR207	1/8"	7/32"
PCR307	3/16"	7/32"
PCR309	3/16"	9/32"
PCR311	3/16"	11/32"
PCR407	1/4"	7/32"
PCR409	1/4"	9/32"
PCR411	1/4"	11/32"
PCR507	5/16"	7/32"
PCR509	5/16"	9/32"
PCR511	5/16"	11/32"
PCR607	3/8"	7/32"
PCR609	3/8"	9/32"
PCR611	3/8"	11/32"
PCR707	7/16"	7/32"
PCR709	7/16"	9/32"
PCR711	7/16"	11/32"
PCR807	1/2"	7/32"
PCR809	1/2"	9/32"
PCR811	1/2"	11/32"
PCR813	1/2"	13/32"
PCR1007	5/8"	7/32"
PCR1009	5/8"	9/32"
PCR1011	5/8"	11/32"
PCR1207	3/4"	7/32"
PCR1209	3/4"	9/32"
PCR1211	3/4"	11/32"
PCR1407	7/8"	7/32"
PCR1409	7/8"	9/32"
PCR1411	7/8"	11/32"
PCR1607	1"	7/32"

'P' Clips - Metric

Part Number	Cable Diameter	Fixing Hole Size
CP105081	8mm	5mm
PCR611	10mm	8mm
CP108121	12mm	8mm
CP106161	16mm	6mm
CP108165	16mm	8mm

Steel Balls

Part Number	Diameter
BLS106	3/16"
BLS108	1/4"
BLS110	5/16"
BLS112	3/8"
BLS28	7/16"

Pop Rivets - Open End Type

Part Number	Diameter
RA607096	2.9 x 5mm
RA608126	1/8" x 3/16"
RA608176	1/8" x 1/4"
RA608236	1/8" x 5/16"
RA608253	1/8" x 3/8"

Pop Rivets - Closed End Type

Part Number	Diameter
RU608123	1/8" x 3/8"
RU608313	1/8" x 1/2"
RU612123	3/16" x 5/16"

Cable Ties

Part Number	Length
GHF1265	3 1/2"
GHF1266	5 1/4"
RTC222A	6"
GHF1267	8 3/4"
GHF1268	11"



PAINT COLOURS

Due to the longevity of the Mini production, which combines 41 years of paints and colour codes, there are far too many to be shown here. Therefore we suggest that you contact your nearest Moss branch and discuss your requirements.

The colours that we supply are carefully blended to be an exact match to the original paint as used by the factory, but it is worth observing that your car may well have faded from its original colour over the years. For this reason before you start, we recommend that you do a test spray of any aerosol on a piece of old metal or a carefully selected area of the car where a mismatch will not be noticed. The boot or spare wheel area is often a convenient place to do your testing.

We can supply paint in either aerosol or brush-on format. The aerosols come in 400ml cans and the brush-on paints are available in 125ml cans with a brush in the cap (except for engine and chassis paints, which are supplied in 500ml tins).

TRIM COLOURS

There are many trim colours for the Mini over the 41 years of production. However Moss only stock, red, black and grey. We can supply these colours throughout the whole range of trim including: boot trim, headlining and sun visors, interior trim panel kits, dash liner kits, carpet sets, footwell cover mats, seat cover kits, gear lever gaiters. For more information please contact your nearest Moss branch.



Red trim

Black trim

Grey trim

Please note: Colours may vary slightly to samples shown here, due to the limitations of the colour printing press, and should be used as a guide only.



Classic Car Colours Stockist: Moss Europe Ltd



DYNOLITE

EUROPE'S CLASSIC MOTOR OIL



Dynolite Oil produces high quality oils and lubricants for vintage, classic and racing applications. Including lubricants for engines, gearboxes, steering boxes and greases. Dynolite lubricants are specially developed for historic vehicles to offer far superior mechanical protection.

www.dynolite.com

Dynolite Stockist: Moss Europe Ltd



LONDON

LONDON

Unit 16, Hampton Business Park
Bolney Way, Feltham
TW13 6DB

London Tel
+44 (0)20 8867 2020

E-mail
sales@moss-europe.co.uk

Fax
+44 (0)20 8867 2030



BRADFORD

BRADFORD

Unit 12-13, Acorn Park Ind. Est.
Otley Road, Shipley
BD17 7SW

Bradford Tel
+44 (0)1274 539 999

Email
bradford@moss-europe.co.uk

Fax
+44 (0)1274 539 990



BRISTOL

BRISTOL

1-3 Elton Street
Bristol
BS2 9EH

Bristol Tel
+44 (0)117 923 2523

Email
bristol@moss-europe.co.uk

Fax
+44 (0)117 942 8236



MANCHESTER

MANCHESTER

111-117 Stockport Road
Stockport, Cheshire
SK3 0JE

Manchester Tel
+44 (0)161 480 6402

Email
manchester@moss-europe.co.uk

Fax
+44 (0)161 429 0349



PARIS

PARIS

7 rue Chaponval
ZAC du Cornouiller
78870 Bailly, France

Paris Tel
+33 (0)1 30 80 20 30

Email
sales@moss-europe.fr

Sav
+33 (0)1 30 80 21 50