

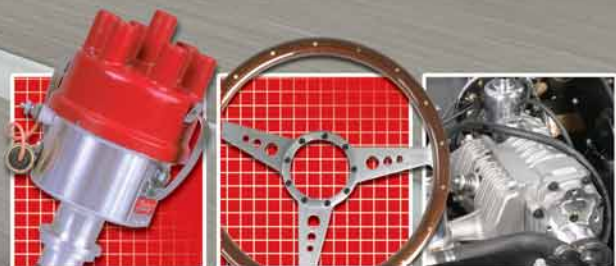

**Moss
Motors**
COOL STUFF FOR COOL CARS

SPRITE- MIDGET

Austin-Healey Sprite
MG Midget
PARTS & ACCESSORIES



CALL TOLL FREE:

800.667.7872

SECURE ONLINE ORDERING!

www.mossmotors.com

A02 | Moss Motors Ltd.

THE BEST IN THE BUSINESS



On the Road with Moss Motors

One of the saddest ends for an automobile is to become a museum piece. Static, with a set of jack stands holding the tires off the ground. The smells and sounds of operation faded away. The laughter, enjoyment and thrills experienced by the owners, merely distant memories.

That's no way to treat a fine British Automobile! Fire up your baby and hit the road! Watch those smiles as you drive by and bring new memories to life. It's the whine of rubber on road and the burble of straight through exhaust in the ear. Wind in the face and warm oil in the nostrils.

Moss Motors will be there with you supplying the parts and know how to keep you on the road. You can also look for our name at club events helping to keep the camaraderie alive. In your British car it's not the destination that's important, it's the drive. We are committed to keeping your car on the road by stocking the parts you need to keep rolling, and also stopping, when necessary.

Check out our new products and look for more to come. The British car hobby is alive and well, and Moss Motors is leading the way with new products to improve safety, performance and reliability.

Expect the Best:

- ✓ Range of Products with new items every month
- ✓ Service, with same day shipping
- ✓ Value for Money
- ✓ Catalogs
- ✓ Website
- ✓ Technical Assistance, Product Knowledge and Quality Control
- ✓ Sales Flyers

Working on automobiles is inherently dangerous. Moss Motors, Ltd. is not liable for injury or damage due to incorrect installation or use of their products. All products are sold with the understanding that the safe and proper installation and use of the products is the customer's responsibility. Follow factory workshop manual procedures and instructions, but use current shop safety standards and common sense. Some tasks will require professional advice or services which Moss Motors cannot provide.

Contents | A03

FIND WHAT YOU NEED FAST
... PG.A36



We Carry All of
Your Favorite Brands!

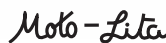

SPM-0508

A04 | New Products!

THE LATEST FROM MOSS MOTORS



British Standard Pipe Taps

Most British fuel and oil lines have British Standard Pipe (BSP) fittings. These taps can be used to clean threaded fittings, the 1/8" BSP is useful for oil gauge lines and 1/4" BSP fittings are used on many fuel line applications.

1/8" BSP Tap	385-760	\$22.25
1/4" BSP Tap	385-765	28.90

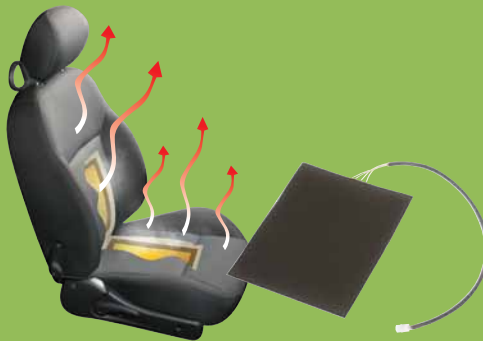

Seat Heater

A little warmth in the right place can really make driving more comfortable. This therapeutic seat heater has dual zones and two settings to keep your bottom and lower back toasty. Designed to be installed under existing upholstery or seat covers, this kit is suitable for alternator-equipped cars. Sold as a set for one seat.

Seat Heater Kit	903-250	\$129.95
-----------------	---------	----------



Hazard Switch Kit

This is a period accessory that allows four way flashers to be hooked up on a British car that was not originally equipped with them. This kit does require cutting and splicing of the original vehicle wiring so it should be installed by someone proficient with British electrical wiring.

Hazard Flasher Kit	635-625	\$98.95
--------------------	---------	---------



Heated Blanket

Keep your knees toasty with this 12V heated blanket. 42" x 58".

Electrically Heated Blanket	002-842	\$34.95
-----------------------------	---------	---------

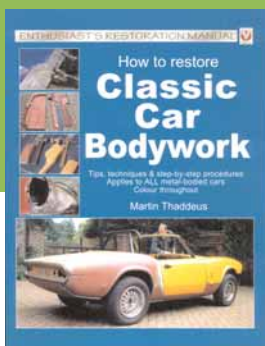

Book: How to Restore Classic Car Bodywork

We have been waiting for a comprehensive book that details typical bodywork needed by our classics including door skins, floor and sill replacement and rust repair. This book covers all these restoration techniques and is packed full of photos of denuded MGs and Triumphs being given a new lease on life. Softbound, 8" x 10 1/2", 112 pages.

How to Restore Classic Car Bodywork by Martin Thaddeus	212-416	\$32.95
---	---------	---------



Right Stuff Gasket Maker

The latest in Elastomeric Rubber Gasket technology. Useful for hard to seal areas such as differentials and oil pans. Resists coolant, oil and ATF. 5 oz

221-450	\$18.95
---------	---------



Roll Around Pneumatic Shop Stool

Improve your mechanical abilities by using the right tool for the job. Don't succumb to the detrimental effects of straining or over-exertion while working on your vehicle. This new Roll-Around Pneumatic Stool will definitely make your job easier, increasing your productivity in the garage. With pneumatic action, the seat quickly adjusts up to 20 inches tall. This stool also features a convenient 15-inch diameter tool tray to keep the tools or parts you need within easy reach. Shielded 2.5-inch casters make moving around the garage a breeze. A big, fully padded 12-inch diameter seat provides comfort for those long projects.

336-735	\$34.95
---------	---------



Sheepskin Wash Mitt

The natural sheepskin fibers hold soap and gently remove grime without paint damage.

Sheepskin Wash Mitt	231-645	\$7.95
---------------------	---------	--------



Drink Holder

Oversized 3 1/4" diameter opening will receive any cup and hold it securely. Sturdily constructed and flocked in Charcoal Grey material to complement any interior. Best of all, it is secured in place by sliding over the edge of your floor mat so you can use it in any automobile.

Large Drink Holder	100-785	\$21.95
--------------------	---------	---------

New Products! | A05

THE LATEST FROM MOSS MOTORS



Early Sleeved Type Thermostat

The original design of most British cars called for a sleeve type thermostat, which blanks off the bypass port when the engine is hot. This type of thermostat has not been available from the factory for many years. The amount of water that is allowed to bypass the radiator with modern replacement thermostats is enough to cause overheating in marginal engines. Early Triumphs and Jaguars in particular have large bypass ports and cooling can be improved by installing our reproduction of the original style thermostat.

Reproduction Early Sleeved Type Thermostat
434-156 \$38.95



New Barbarian Rugby Shirts

The Genuine article: 12-ounce 100% pre-shrunk cotton, reinforcing patches, rubber buttons, overlocking heavy-duty seams.

AHY	Rugby Shirt Medium	013-495	\$76.95
AHY	Rugby Shirt Large	013-496	76.95
AHY	Rugby Shirt XLarge	013-497	76.95
AHY	Rugby Shirt XXLarge	013-498	76.95
MG	Rugby Shirt Medium	013-500	76.95
MG	Rugby Shirt Large	013-501	76.95
MG	Rugby Shirt XLarge	013-502	76.95
MG	Rugby Shirt XXLarge	013-503	76.95



New Golf Shirts

100% pre-shrunk cotton golf jersey. Solid Oxford Grey body with contrasting tri-color checker collar and cuffs.

MG	Golf Shirt Medium	013-515	\$37.95
MG	Golf Shirt Large	013-516	37.95
MG	Golf Shirt XLarge	013-517	37.95
MG	Golf Shirt XXLarge	013-518	37.95
AHY	Golf Shirt Medium	013-520	37.95
AHY	Golf Shirt Large	013-521	37.95
AHY	Golf Shirt XLarge	013-522	37.95
AHY	Golf Shirt XXLarge	013-523	37.95



Trash Container

Put trash in its place. Our handy receptacle measures 4" in diameter and 5" tall. Securely stays in place by sliding over the edge of your floor mat. A removable plastic liner makes emptying easy.

Trash Bin 101-140 \$29.95



Dash Panel Covers

This cover completely replaces the existing foam and vinyl on the later padded dashboards. Now you can totally renew the cockpit of your padded dash Midget.

Dash Panel Cover, '68-'74 453-815 \$249.95
Dash Panel Cover, '75-'79 453-816 249.95



Alternator Conversion Kit

Complete kit of all parts and instructions to convert from generator to alternator. Does not have provision for Bugeye Tach. Drive.

Alternator Conversion Kit 130-068 \$179.95



Intermittent Wiper Kit

A comprehensive instruction sheet simplifies installation.

Intermittent Wiper Kit 161-250 \$55.00



Parking Sign

For your office parking lot or car show. You know you need one.

Austin-Healey Sprite Only Parking
215-970 20.95

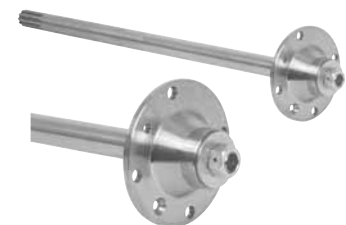

Upgraded Axle Shaft

Heavy duty shafts are machined out of EN30B Steel and heat-treated to 39-41 Rockwell hardness. The drive flange is a spline fit to reduce failures and is machined from EN24T steel for durability. For disc wheel applications only.

Competition Rear Axle Shaft 265-305 \$325.00

A06 Interior

STEERING WHEELS



Wheel Adapters

Complete adapter kits include:

Hub, Horn Push and emblem.	28mm Plastic Emblem	46mm Enamel Emblem
Midget MkI '61-63	905-345	905-348
Midget MkII, III '64-'67	454-365	454-366
Midget MkIII '68-'69	905-470	905-468
Midget MkIII 1970	905-475	905-476
Midget MkIII 1500 '71-'77	905-480	905-482
Midget 1500 '78-79	905-485	905-486
Sprite MkI, II '61-63	905-345	905-346
Sprite MkIII, IV '64-'67	454-365	454-368
Sprite MkIV '68-'69	905-472	905-478
Horn push with emblem available separately.	\$22.95	\$28.95
With Healey Emblem	905-618	905-648
With MG Emblem	905-616	905-646



TOURIST TROPHY



Tourist Trophy Wheels

Tourist Trophy offers a complete selection of wood and leather steering wheels for most British automobiles and they are the best looking steering wheels we could find. Your choice in finish, material, grain, width and feel—it's the perfect way to personalize your interior. Made to the highest standards using aluminum frames for lightweight strength. Requires additional adapter hub sold separately.

Wood Rimmed Steering Wheels

(06) 14" 3-spoke Matte/Drilled	489-070	\$219.95
15" 3-spoke Matte/Drilled	489-060	219.95
(07) 15" 3-spoke Matte/Slotted	489-080	219.95
15" 3-spoke Matte/Drilled (extra thick rim)	489-090	219.95

Leather Rimmed Steering Wheels

15" 3-spoke Black/Drilled	489-010	\$199.95
(08) 14" 3-spoke Black/Drilled	489-040	199.95
15" 3-spoke Black/Slotted	489-050	199.95
(09) 14" 3-spoke Matte/Drilled	489-030	199.95
15" 3-spoke Matte/Drilled	489-020	199.95

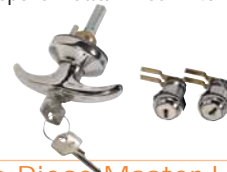

Three Piece Master Lock Set

Replaces both doors and trunk lock assembly with matching key. 470-458 \$72.95

Leather Steering Wheel Cover

This premium grade black leather cover is custom tailored to fit 16 1/2" rims. Simple installation results in a quality factory-fitted appearance. 222-315 \$42.95



Moto-Lita Steering Wheels

Moto-Lita steering wheels employ attractive bicolored wood laminations or black leather over aircraft aluminum frames. Requires additional adapter hub sold separately.

Wood Rimmed Wheels

(01) 14" 3-spoke Polished/Drilled	499-560	\$319.95
15" 3-spoke Polished/Drilled	499-540	319.95
(02) 15" 3-spoke Polished/Slotted	499-580	319.95

Leather Rimmed Wheels

(03) 14" 3-spoke Polished/Drilled	499-520	\$319.95
15" 3-spoke Polished/Drilled	499-500	319.95



Center Console & Armrest

Similar to vintage aftermarket consoles made by Amco some years ago. Black grained ABS thermoplastic base with leather covered armrest. A large storage compartment is located under the armrest pad and a cup holder is located in the forward portion.

453-805 \$116.95

Rubber Mats | 04



Embroidered Mats | 05



(04) Rubber Floor Mat Sets

Protect your carpets from dirt, wear and fading. If mats get dirty, hose them down and return them to the car. Set of two. Black.

Spridget/Side Curtains	241-870	\$29.95
Midget MKII-1500	241-860	29.95
Sprite MkII & MkIV	241-880	29.95

(05) Embroidered Carpet Mat Sets

Deep, tufted dense cut pile carpet with non-slip backing and rolled edge binding and embroidered marquee logo. Crush resistant, treated to minimize staining and easy to clean. Black only.

Sprite	240-470	\$88.95
Midget '61-'74	240-480	88.95

Ignition Key Blanks

Original keys are extremely rare. Keys are blank and must be cut locally. Order by the series number of your locks.

	Crested	NonCrested	BL
	\$8.95	\$2.75	\$13.95
MRN Series	163-310	163-510	-
FA Series	163-320	163-535	-
FS Series	163-330	163-545	-
FP Series	163-340	163-550	-
AA Series	163-370	-	163-375
MG Series	-	-	163-365
RV Series	163-380	-	163-355
WS Series	-	-	163-345
BL Series	-	-	163-335

Interior | A07

SEATBELTS



Inertia Reel Seat Belt | 10

(10) Inertia Reel Seatbelts

We have a great source for quality American made Inertia Reel seatbelts, suitable for Spridgets. Black with a stalk mounted receiver similar to that originally fitted in 1974 and later cars. Includes mounting hardware.
 Black Seatbelt 222-025 \$99.95



Vintage Competition Seatbelt | 11

(11) Vintage Competition Belts

Quick release buckle with mounting hardware included.
 222-211 \$83.75 ea.



Vintage Style Seatbelt | 12

(12) Vintage Style Seatbelts

Black webbing with solid steel, chrome plated aircraft style buckles. Sold individually. The substantial webbing length can be trimmed for safe operation. Mounting hardware included.
3-Point Belt, Short (93" shoulder side, 12" on the lap side) 222-204 \$41.95
2-Point Belt, Short (38" adjustable clasp side, 20" tongue side) 222-234 23.95
3-Point Belt, Long (93" shoulder side, 20" on the lap side) 222-205 41.95
2-Point Belt, Long (38" adjustable clasp side, 30" tongue side) 222-235 23.95

Standard Seatbelt

Sold individually with alloy steel mounting hardware.
 Standard Seatbelt 222-215 \$28.95



Seatbelt Shoulder Pads

Comfort, with a dash of color.
 Red Logo 231-300 \$19.95
 White Logo 231-301 19.95

Inflatable Lumbar Support

This manually adjustable pneumatic lumbar support fits easily under the seat back upholstery of most cars. Once it's in place, simply pump it up to fit your back.

650-100 \$54.95



Brooklands Racing Screens

Reproduction of the traditional Brooklands Racing Screen. Screen includes a polished aluminum frame, safety glass and chrome plated brass mounting hardware.
 224-100 \$139.95

Dashlight Flashlight

Plug this flashlight into your cigarette lighter. This small, yet high-powered light re-charges as you drive. LED charge indicator lets you know when it is fully charged.
 900-005 \$13.95



Expandable Cup Holder

Our retractable cup holder mounts nearly anywhere. The arms adjust in or out to the size of your container, and it folds up when not in use.
 222-090 \$13.95



Cloisonne Leather Key Fobs

MG Black & Chrome 229-800 \$12.95
 MG Red & Chrome 229-890 12.95
 Union Jack 229-885 11.95



Leather Key Fobs

MG Key Fobs
 Brown 229-802 \$7.95
 Black 229-801 7.95
Austin-Healey Key Fobs
 Brown 915-316 \$7.95
 Black 915-315 7.95



Insulation Materials

Sound Control Super Insulation

Install on doors, floors or firewall. Dynamat's modified asphalt polymer deadens body panel vibrations. The 5 mil aluminum top layer combines heat resistance with noise deadening. 3' x 4' rolled sheet.
 Dynamat Insulation 409-026 \$99.95



Dynamat Hoodliner

Hoodliner absorbs engine noise with .75" thick Sound Soaker urethane foam and prevents hood paint failure. Reflects 97% of radiant heat while providing engine insulation. 3' x 4'.
 409-005 \$89.95



Space-Age Heatshield Material

Foil covered felt, heat and sound deadening material installed under carpets, over the transmission tunnel, against the firewall, etc. Insulates against hot and cold, and provides protection against fire. Sold in 48" x 72" sheets, cuts easily.



Heat Shield Material 409-015 \$29.95
 Heat Shield Adhesive 409-035 9.95
 Aluminum Foil Tape 409-065 4.95

Dynashield Insulation Spray

Use as a thermal shield, undercoat, gravel guard and rust protector. Dries to a paintable black finish. Seals joints and crevices from corrosion caused by water and road salt. 10.5 oz. can covers five square feet. No air shipment.
 409-125 \$21.95



OE Style Cigarette Lighter

To replace a defective original, or add an electrical outlet to earlier cars. This kit includes a complete illuminated lighter assembly as fitted to many British cars. 142-270 \$36.95



Twin Air Horns

Our twin tuned air horn set includes two tuned air horns, heavy duty die cast compressor, air hose, mounting hardware and installation instructions.
 Horns 545-080 \$41.95



Accessory Shift Knobs

Each with a cloisonné medallion.

Walnut Crested

Midget 228-780 \$17.95
 Sprite 228-760 17.95

Black Vinyl Crested

Midget 228-790 \$17.95
 Sprite 228-770 17.95



A08 Interior Upholstery



Vinyl Seat Kits

	Black with White Piping	Red with White Piping	Blue with Blue Piping	
A Bugeye Sprite, 948 Sprite Mk II to HAN7-24731	640-770	640-780	640-790	\$335.95
B 948 Midget Mk I to GAN1-16183	640-895	640-905	640-915	\$335.95
C 1098 Sprite Mk II & Mk III from HAN7-24732 to HAN8-55500				
Midget Mk I & Mk II from GAN2-16184 to GAN3-52389	640-855	640-865	640-875 (Navy/Navy)	\$347.95
			640-876 (Lt.Blue/Wht)	\$48.95
D 1098 Sprite Mk III & 1275 Mk IV from HAN8-55501 to HAN9-77590				
1275 Midget Mk III to GAN4-66225	640-910	640-920	640-840	\$347.95
E 1275 Sprite Mk IV from HAN9-77591 to HAN9-85286				
1275 Midget Mk III from GAN4-66226 to GAN4-74885	640-945 (Black, fixed back*)			\$347.95
	640-950 (Black, reclining back*)			\$50.95
	(*Headrest covers not included)			
F 1275 Sprite Mk IV from HAN10-85287 on				
1275 Midget Mk III & Midget 1500 from GAN5-74886 thru 1500	Black*	Autumn Leaf*	Navy*	
	640-960	640-980	640-930	\$338.95
	(*Headrest covers not included)			

Leather Seat Kits

	Black with White Piping	Red with White Piping	
Bugeye Sprite, 948 Sprite Mk II to HAN7-24731	640-775	640-785	\$863.95
948 Midget Mk I to GAN1-16183	640-880	640-885	\$945.95
1098 Sprite Mk II & Mk III from HAN7-24732 to HAN8-55500			
Midget Mk I & Mk II from GAN2-16184 to GAN3-52389	640-825	640-835	\$914.95
1098 Sprite Mk III & 1275 Mk IV from HAN8-55501 to HAN9-77590			
1275 Midget Mk III to GAN4-66225	640-845	640-925	\$960.95
1275 Sprite Mk IV from HAN9-77591 to HAN9-85286			
1275 Midget Mk III from GAN4-66226 to GAN4-74885	640-800 Black, fixed back		\$945.95
	640-955 Black, reclining back		\$803.95
1275 Sprite Mk IV from HAN10-85287 on			
1275 Midget Mk III & Midget 1500 from GAN5-74886 thru 1500	Black	Autumn Leaf	
	640-805	640-810	\$917.95



Sprite & Midget Upholstery

Restore your Sprite or MG Midget to original specifications with British made reproduction upholstery kits. With duplicated original patterns, vinyls, and even dielectrically welded seams where appropriate, your car will look factory new. Our seat and panel kits are complete and straightforward to install. The seat kits (see pages 64-65) include squab and cushion covers along with seat back extension covers where appropriate. Panel kits include sufficient vinyl to cover your dash panel and cockpit as required, new footwell boards, gearbox tunnel boards, inner sill boards, door pocket boards and rear quarter panels.

Moss Seat Kits

All front seat kits include covers for both front seats. No matter what else you do to your car, one thing which everyone notices is the condition of the seats. Put your seats in tip top condition with a "just as it came from the factory" vinyl kit, or upgrade your car's interior with one of our luxurious leather kits. (Don't forget pads and cushions - we stock a complete selection to properly fill out your new covers, and make your "new" seats as comfortable as can be.) All of the Sprite & Midget seat kits we sell are made in England of the very best materials, patterned exactly like the originals.

Free sample cards are available: Upholstery 878-160, Carpet 878-360.

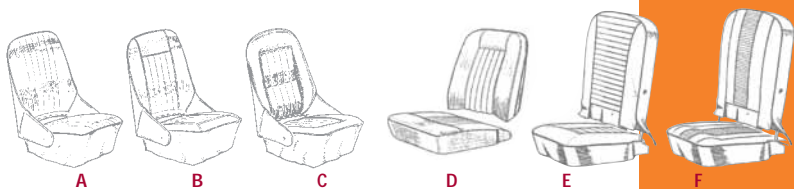

Interior | A09

UPHOLSTERY



A D D

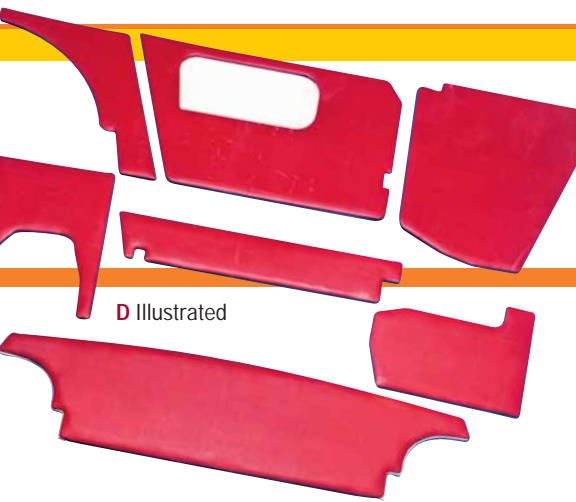

D Illustrated

Aluminum Cover Plates | 01

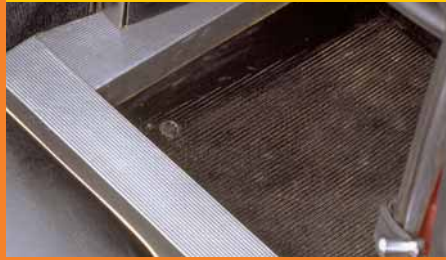

Ribbed Aluminum Trim Plates

Threshold Plates

Our threshold plates are easy to install. Add a custom touch while protecting your door sills from scuffs and scratches. Set of two.
 Sprite 240-660 \$25.95

Ribbed Aluminum Frame Cover Plates

Four piece set to cover the exposed frame sections in your interior.

- (01) 1/4 Elliptic Springs 240-510 \$69.95
- 1/2 Elliptic Springs 240-550 69.95



Seat Savers

These seat covers feature cool, comfortable, washable heavy-duty poly/cotton blend. Storage pocket on the backrest. Sold in pairs. Fits Midgets from '70 thru '78.

- Black Seat Savers 237-350 \$104.95
- Tan Seat Savers 237-360 104.95



'68-'80 Dash Pad Covers

Revitalize your old cracked dash top pad with this molded ABS cover. Comes complete with adhesive and instructions. 453-950 \$49.95



Walnut Door Caps

Bring a touch of real wood luxury to your car. Easily installed in place of the original vinyl covered caps. Fits all Sprites/Midgets from 1964 on. 2 Pc Door Cap Set 233-690 \$449.95



Seat Slides, Foams, Door Seals & Hardware

You'll find a complete listing of all the interior components we offer that you need to restore your Sprite or Midget on Page 133-135.

BLACK CUT PILE

RED CUT PILE

BLUE CUT PILE



Carpet Sets

Sprite & Midget with Side Curtains

- Black Carpet Set 242-530 \$276.95
- Red Carpet Set 242-540 276.95
- Blue Carpet Set 242-550 276.95

Sprite & Midget with Wind-Up Windows

- Black Carpet Set 242-560 \$279.95
- Red Carpet Set 242-570 279.95
- Autumn Leaf 242-580 279.95



Midget Headrests

Beautiful reproductions of an often missing or weather-ruined upholstery part. (Sorry, twin-post headrests for 1969 cars are not available.)

1970-3/77 "Eared-type" Perforated Headrests

- Black 649-100 \$62.95
- Navy NA
- Ochre NA
- Autumn Leaf 649-130 62.95
- Champagne NA

1977-'80 "Teardrop-type" Non-perforated Headrests

- Black 641-605 \$63.95
- Navy 641-615 73.95
- Ochre NA
- Autumn Leaf 641-635 73.95
- Champagne 641-535 73.95



Cockpit Panel Kits

approx. model yr.	Black	Red	Blue
A Bugeye Sprite 1958-'60	\$269.95 645-500	645-510	645-520
B 948 Sprite MkII 1961-'62	\$349.95 645-540	645-550	645-560
948 Midget MkI			
C 1098 Sprite HAN7 1963	\$419.95 645-620	645-630	645-640 (Navy)
D 1098 Sprite HAN8 1964-'66	\$426.95 645-570	645-580	645-585 (Light Blue)
Midget GAN2			
D 1275 Sprite HAN9 1967-'69	Black with Black Piping \$419.95 645-660	Black with White Piping 645-670	Red with White Piping 645-680
1275 Midget GAN4			
E 1275 Midget GAN5 1970-'80	\$282.95 Black 645-700	Navy 645-710	Autumn Leaf 645-720
1500 Midget GAN6			

A10 | Exterior

Badge Bar Badges

A	Cloisnone RAC	408-517	\$40.95
B	Queen Elizabeth	408-376	44.95
C	BMC Driver's Club	408-375	40.95
D	R.A.C. Badge	408-695	89.95
	St. Christopher	408-435	106.95
E	Brooklands	408-175	64.40
F	Coat of Arms	408-185	59.95
G	Lucas	408-705	59.95
	British Racing	408-379	59.95

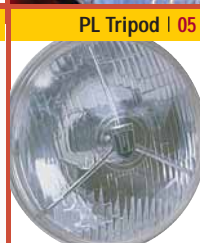

Hella Halogen Headlamp

Accurate optics and reflector put the light where it is needed. Safe for all vehicles originally equipped with 7" sealed beam headlamps. (sold each)

Hella Halogen Headlamp	902-997	\$37.95
Replacement H4 bulb	902-998	5.95

Grille Badges

Solid baked enamel finish on a polished stainless steel back.

England	408-507	\$19.95
U.S.A.	408-527	19.95
RAC	408-547	19.95



Cloisnone Union Jack

Designed to mount on flat surfaces. 2 1/4" x 1 3/8". Set of 2, screws included.

Cloisnone Badges	229-308	\$29.95
------------------	---------	---------

Chrome GB Letter Set

Chrome plated brass letters. Stud mounted letters require four small holes drilled in the car. Letters are pliable to follow for curved surfaces.

GB Letter Set	230-120	\$41.95
---------------	---------	---------

International Sticker

International country of origin insignia. Regulation size, self adhesive.

International Sticker	230-110	\$3.25
-----------------------	---------	--------

Magnetic Union Jack

No drilling required.

	215-330	\$6.95
--	---------	--------



Leather Bonnet Straps

Accurate reproduction of the works type straps fitted to race & rally cars.

Tan, each	222-730	\$46.95 ea.
Black, economy, set of 2	222-600	20.95



Badge Bars & Mounting Hardware

Dress up the front of your car. Badge bars do not fit Bugeye or 1500.

Sprite/Midget	451-085	\$74.95
Sprite/Midget w/driving light mounting lugs	451-075	117.95
Backing Plate	408-577	6.95
Clip (3/4" bar)	408-567	5.55



Wind Blockers

Cut down on wind noise and buffeting. Easily installs to cut down fatigue on long trips with the top down.

Midget '61 -'66	458-293	\$219.95
Midget '66 -'80	458-291	219.95

Halogen Headlamp Bulb for Early British Lamps

This Prefocus Headlamp bulb replaces Moss #170-600 or Lucas LLB370 and uses a 65/55W H4 Halogen bulb to give work in our PL700 Tripod Headlamps.

Halogen Prefocused Headlamp Bulb	170-695	\$19.95
----------------------------------	---------	---------



Trunk Lid Stay, Self-Triggering

This replacement for the stock stay rod makes opening and closing your trunk a one hand operation. It comes with easy to follow instructions, and all necessary hardware is available.

	406-985	\$20.95
--	---------	---------



Exterior | A11

ACCESSORY LAMPS

Tripod Headlamp Set

For that classic look, Moss Motors offers two versions of the Classic Tripod Headlamp. The P700 was a step up from the standard headlamp and featured an internal tripod reflector with round center cap. Our reproductions capture the look and vintage design of these lamps.

- (04) P700 Tripod Lamp Set
 156-878 \$176.95
 Replacement bulb for above lamps
 170-600 8.40

The PL700 was fitted to many Jaguars and high level sports cars. The unique lens design and prominent PL badge give a distinct look that is part of the historical heritage of our cars. These lamps are reputed to have been made on original tooling, but the quality of the lens silvering and detailing is not as crisp as original samples we have of the PL lamp.

- (05) PL Tripod Lamp Set
 156-898 \$341.95
 Replacement bulb for PL700 lamps
 170-650 8.15

(06) 7" Halogen Headlamp Set

Made in the UK by Wipac, these high quality headlamps come with replaceable H4 bulbs. Fits all regular 7" headlamp applications.

- Wipac Headlamp Set 162-725 \$107.95
 Replacement H4 Bulb 162-755 12.95 ea.

Fog and Driving Lamps

Quality reproductions of the classic 5 1/2" Lucas 500 series SLR and SFT lamps as originally fitted to many cars of the '50s and '60s.

Driving Lamps:

- Stem mount 162-700 \$139.95
 Back mount 162-760 139.95

Fog Lamps:

- Stem mount 162-800 139.95
 Back mount 162-770 139.95

Lamp Covers:

- 6" dia. Fits above 500 series lamps.
 162-705 43.95
 7" dia. Fits Lucas 700 series lamps.
 162-865 48.95

Replacement Bulbs:

- Driving Lamp Bulb 170-500 2.95
 Fog Lamp Bulb 170-510 4.15



Halogen Classic Lamps

Upgrade your classic with halogen lamps. It's a great way to maintain the classic look and improve visibility. 5 1/2" Lens, Depth 2", 3/8" diam. Stud.

- Driving Lamp 162-835 \$34.90
 Fog Lamp 162-836 34.90
 Replacement Bulb 162-765 5.60 ea.

Bugeye Rack | 07



Luggage Rack | 08



(07) Bugeye Luggage Rack

Factory style rear luggage rack. Features strap mounting tabs. Measures 30.5" x 16".
 244-720 \$379.95

(08) Luggage Rack

This stainless steel beauty measures 34.5" x 15". Fits Midget MkI and Sprite MkII on.

- Luggage Rack 244-730 \$329.95



New!

Headlamp Covers

Now you can demonstrate your patriotism. Definitely not legal for driving, but these could be a hit at your next car show.

- Union Jack 169-205 \$19.95
 US 169-210 19.95



Magnetic 3rd Brake Light

An added measure of safety when driving to and from events. Easy removal. Light unit mounted on a heavy chrome magnet assembly. Easily connects to your existing wiring harness.

- 164-005 \$109.95

License Plate | 09



Pressed English License Plates

Regulation British plates are identical to those used in England from the '40s, to early '60s. Up to seven semi-sheared raised letters and numbers of your choice. Pre-masked to paint the background the color of your choice.

- (10) 307-073 \$63.95

Headlamp Cover | 10



StoneGuards | 11



(10) Headlamp Cover

Rigid clear plastic headlamp covers protect your 7" headlamps from rock damage. Fits most 7" headlamp applications. 169-200 \$17.95

(11) Headlamp Stone Guards

Heavy duty chrome plated wire mesh stone guards protect your headlights.*

- Stone Guards 222-100 \$12.95
 *May not be street legal.

Electric Screen Jet Kit

UK-made reproduction of the Lucas screen jet washer. Includes an authentic Lucas Screen Jet label.

- Screen Jet 546-125 \$508.95



Lucas-Style Windtone Horns

Reproduction of the famous units fitted to many British cars. Set of Two.

- 165-708 \$139.95



A12 Exterior

MIRRORS & HARD TOP

Lucas Style Reproduction Mirrors

(01) Flat Wing Mount	223-310	\$30.95
(02) R/H, flat lens	165-400	14.95
L/H flat lens	165-500	14.95
R/H convex lens	165-210	14.95
L/H convex lens	165-300	14.95



Chrome Backplate

Available separately, with Lucas logo.
165-307 \$11.95

Bullet Mirrors



Combination Mirror

Has two base options. Short base is 2.25" with bolt holes 1" apart. Long Base is 4.75" with bolt holes 3.5" apart.

222-372 \$43.95

Short Base with Oversize Lens

Dimension- Base 3.0" Bolt hole 1.25"

222-390 \$87.95

Raydyot Racing Mirrors

Made of lightweight aluminum, our American made reproductions are sturdy and have the "brushed" finish as original.

222-355 \$68.95 ea.

License Plates

Display your loyalty with one of our regulation size license plates. Embossed aluminum plates with crisp screen printing.

Union Jack Plate	229-730	\$8.95
MG Logo Plate	229-735	8.95



Clear Cover License Frame

Protect your plate with this new frame. It features a one-piece durable plastic lens with gasket. Easy to install, this frame will isolate your plate from moisture and dirt. The kit includes stainless steel fasteners. (Check your local DMV regulations.)

222-705 \$26.50

Wing Mount Mirror | 01



Electric Antenna | 03

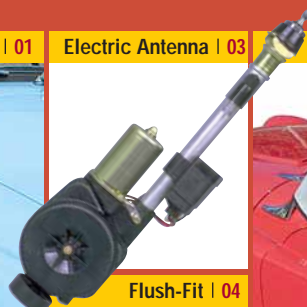

Flush-Fit | 04

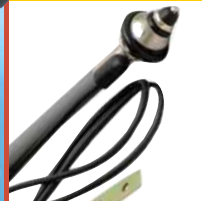

Wing Mount Mirror | 01



Rubber Antenna | 05



Antennas

(03) **Electric Retractable Antenna:** Our electric antenna kit wires into your radio for fully automatic operation. Requires 13.5" depth to mount
386-960 \$88.65

(04) **Flush-Fit Radio Antenna:** Collapsible. Requires 9.5" depth to mount.
386-970 \$9.95

(05) **14" Rubber Antenna Black.** Includes 54" lead.
900-716 \$12.95



License Frames & Screws

High quality frames that show off the heritage of your car.

Morris Garage	222-830	\$38.95
Union Jack Black	222-735	32.95
Union Jack Stainless	222-725	35.95
Sprite Frame Stainless*	222-880	38.95
Midget Frame Stainless*	222-875	38.95
Midget Frame Black*	222-850	32.95
MG ABS Plastic	222-720	4.95
MG Safety Fast Stainless	222-776	38.95

*Standard mounting hardware included.

MG Screws	215-865	\$13.95
Austin Healey Screws	215-885	13.95
Union Jack Screws	215-915	13.95

Stainless steel screws are logo-embazoned. Set of four with 6 x 1.0 metric thread.

Cockpit Cover | 06



(06) Cockpit Cover

If you don't have time to raise the top or use your car cover, this will protect your interior from sun damage and heat build up. Saves your interior from cracking and fading.

Sprite-Midget '69-'78 237-815 \$44.95



New!



Screw Cover Set

These covers are intended for use on license plate bolts. We are looking forward to seeing other creative uses for them at the next car show.

MG Logo	215-837	\$12.95
Union Jack Logo	215-853	12.95
AH Shield Logo	215-847	12.95
AH Wings Logo	215-834	12.95

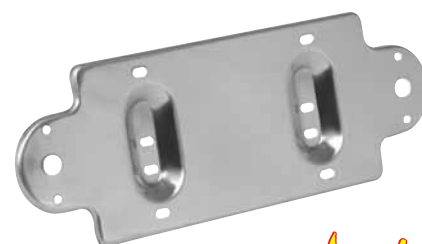

New!

Stainless License Plate Support

Add a touch of sparkle to your ride. Polished stainless steel resists corrosion and brightens up later rubber bumper MGBs and Midgets.

451-296 \$40.95

Exterior | A13

CAR COVERS

Car Capsule | 07



(07) Car Capsule

Keep your car dust free, clean, dry, and protected from rodents, insects, scratches and other dangers. Park the vehicle on the laminated rubber base mat (which is impervious to gas and oil), zip the clear 8 mil PVC double-sewn cover over the car, and plug in the fan which provides continuous airflow to prevent corrosion, mildew, and musty odors. Short or long term storage. Car Capsule operates for under \$1.50 per month. Two year material and craftsmanship guarantee. Fan motor is rated for five years of continuous running. Indoor use only.

- 14' Size Car Capsule
238-600 \$399.95
- 16' Size Car Capsule
238-610 419.95

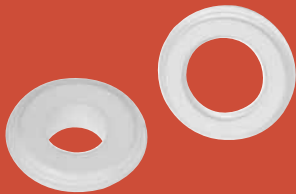

Plastic Antenna Grommet

237-495 \$0.35

(08) Duravent Car Cover

If your car is constantly exposed to the elements, the Duravent cover is for you. Water resistant, yet breathable, this cover works indoors and outdoors in virtually any condition. Features include double-stitched seams with neoprene elastic sewn in the front and rear bases for a snug fit, and scratchproof grommets for locking or tying down your cover. This cover has a body specific fit for easy installation and carries a four-year warranty. Suitable for outdoors in uncovered areas.

Sprite-Midget (not 1500) 237-460 \$109.95
Midget 1500 237-470 109.95

(09) Ultralon Embroidered

Maximum protection for your classic. Three layers of fabric offer excellent protection from dust and moisture, yet allow condensation to evaporate. Lightweight, compact and fast drying to allow easy storage. Proudly emblazoned with an embroidered British flag. Five Year Warranty

Sprite-Midget (not 1500) 237-465 \$214.95
Midget 1500 237-475 214.95

(10) Flannel

This is the upper end of the car cover spectrum for indoor-only use. Features include double-stitched seams with neoprene elastic sewn in the front and rear bases for a snug fit, and scratchproof grommets for locking or tying down your cover. This cover has a body-specific fit for easy installation and carries a two-year warranty. Suitable for garaged areas only.

Sprite-Midget (not 1500) 238-460 \$149.95
Midget 1500 238-470 149.95

Duravent | 08



Flannel | 10



Ultralon Embroidered | 09



Duravent | 08



	ULTRALON	DURAVENT	FLANNEL
WARRANTY	5 YEAR	4 YEAR	2 YEAR
CUSTOM FIT	YES	YES	YES
GROMMETS	YES	YES	YES
BREATHABILITY	★★★★★	★★★★★	★★★
UV RESISTANCE	★★★★★	★★★★★	★★★★★
STRENGTH	★★★★★	★★★★★	★★★★★
STORAGE	★★★★★	★★★★★	★
DUST & DIRT	★★★★★	★★★★★	★★★
POLLUTANTS	★★★★★	★★★★★	★★★
ACID RAIN	★★★★★	★★★★★	★★★
SCRATCH DEFENSE	★★★★★	★★★★★	★★★★★
HEAT RELEASE	★★★★★	★★★★★	★★★



Front Vest

These durable vests help protect your paintwork from stone chips, bugs and other flying debris. Black vinyl, with straps that clip over your car's fender, easy attachment and removal.

Spridget 1962-'69 242-887 \$109.95

Fiberglass Hardtops

From Roadster to GT in 1 minute. A fiberglass hardtop is the ultimate accessory for comfortable year round motoring. Hand laid fiberglass construction and aircraft grade plexiglass windows give the highest strength and lightest weight. The secure stainless steel mounting system assures tight fit and ease of removal. Comes ready to paint, requires surface shipping.

'67-'79 Sprite-Midget 458-305 \$999.00 *
*Factory Direct Order

Desiccant Pouches



Moisture absorbing pouches keep interiors dry during storage. One pouch in each footwell helps guard against mildew and rot for up to six months.

229-995 \$18.95 pair



A14 | Wire Wheels & KNOCKOFFS

60-Spoke Wire Wheel | 01



Panasport Wheels | 02



New!

Knockoffs

Choose the original 2-eared style, or the more exotic 3-eared style. Earlier cars have fine 12 threads per inch, later cars use a coarser 8 threads per inch. Our MG crested knockoffs were original equipment on MGT & MGA, but would look great on your Midget.

MG Crested 2-Eared Knockoffs

Fine Thread (12 t.p.i.)

Left Hand	200-220	\$36.95
Right Hand	200-210	36.95



Standard 2-Eared Knockoffs

Fine Thread (12 t.p.i.)

Left Hand	200-280	\$36.95
Right Hand	200-290	36.95

Coarse Thread (8 t.p.i.)

Left Hand	674-680	\$39.95
Right Hand	674-670	39.95



3-eared Knockoffs

Fine Thread (12 t.p.i.)

Left Hand	200-315	\$81.95
Right Hand	200-325	81.95

Coarse Thread (8 t.p.i.)

Left Hand	200-335	\$86.75
Right Hand	200-345	86.75

(01)

Wire Wheels

An essential part of your Spidgets styling. Whether standard or not, a set of chrome wire wheels truly enhances the appearance of your car.

Dia/Width	Spokes	Finish	Unit	Part #	Price
13" x 4"	60	Chrome	Each	454-685	\$303.95
13" x 4"	60	Chrome	Set (4)	454-648	1,149.95
13" x 4"	60	Painted	Each	454-675	198.95
13" x 4"	60	Painted	Set (4)	454-668	729.95



Bolt-on Sport Wheels

Manufactured using the latest techniques and testing procedures to ensure the highest quality. These wheels carry on the race and rally tradition of the marque.

13" x 5" Sprite/Midget	453-065	\$172.95
Replacement Hub Cap	455-367	13.95
Lug Nut, Sprite/Midget	264-495	1.45
Lug Nut, MG Crest	264-465	3.50



Knockoff Minilite

Designed to replicate the famous racing wheel of the past, this 13" knockoff "Minilite" replica wheel will fit wire wheel hub equipped cars with round rear wheel arches. Please note tire clearance will be tight with some tire sizes.

Bugeye and Roundarch Midget	453-080	\$329.95
-----------------------------	---------	----------

(02) Panasport Wheels

Famous in racing circles, Panasport wheels feature lightweight alloy construction, polished rim and steel tapered-face lug inserts. Please check our website for more information about offset, weight and suggested tire sizes. Please check tire clearance before fitment. Sprite/Midget 13" x 5" +20mm offset, 9.80 lbs

854-835	\$244.95
---------	----------

Inner Tubes For Wire Wheels

155/165 x 13" Tube	452-715	\$16.95
--------------------	---------	---------

13" Bright Trim Rings

Polished stainless steel to provide an attractive accent to your rims. Sold individually. 453-045 \$13.95



Wire Wheels | A15

TOOLS

MG Valve Stem Cap | 03



Valve Stem Cap Sets | 04



Locking Valve Stem Cap Set | 05



New!

(03) MG Valve Stem Cap

Subtle and elegant, these nickel-plated steel valve stem caps feature an MG crest embossed in the top. Sold individually.

Valve Cap 215-825 \$5.20

(04) Valve Stem Cap Sets

Individually machined to exacting specifications. Fitted with an O-ring for proper sealing. Set of 5.

215-835 \$17.95

(05) Locking Valve Stem Cap Set

Like the look of logo valve stem caps, but afraid of theft? These can only be removed with the included tool.

MG Logo	215-836	\$29.95
Union Jack Logo	215-852	29.95
AH Shield Logo	215-846	29.95
AH Wings Logo	215-833	29.95

Inner Tubes & Rim Bands

Designed for use with radial tires and have rubber covered valve stems. (Can be used with bias-ply tires.) Rim bands prevent spoke and nipple ends from chafing your inner tubes. All sold individually.

Inner Tubes

145 x 13" 452-725 \$18.95

Rim Bands

13" Rim Band 452-730 \$14.95



Copper/Copper | 06



1 lb. Zinc | 07



Copper/Hide | 08



4 lb. Zinc | 09



Protective | 10
Knockoff Wrench



Spoke Wrench | 11



Digital Tire Gauge

Improve your fuel mileage and increase handling by simply keeping your tires properly inflated. Digital readings in .5 psi increments ensure accuracy. Features auto shutoff and five year battery.

225-725 \$19.95



Brass Tire Gauge

Solid brass precision gear movement. Push button valve to bleed air to the desired pressure. U.S. and metric scales.

225-715 \$19.95

Wire Wheel Tools

Knock-Off Hammers

All types, weights and sizes for every possible application.

	1lb. Copper/Copper	386-000	\$28.95
(06)	2lb. Copper/Copper	386-850	43.95
(07)	2lb. Copper/Rawhide	386-110	37.95
(08)	1lb. Zinc Alloy	386-020	29.95
(09)	4lb. Zinc Alloy	386-180	30.95

Wire Wheel Spoke Wrench

With its wide face and long handle, this wrench is perfect for adjusting most spoke nipples without rounding them off.

(10) Spoke Wrench 385-800 \$9.95

Protective Knockoff Wrenches

Prevent damage to knock-offs with multi-ply wooden wrenches. The 42mm size fits all conventional British two eared knock-offs.

(11) 42mm Wrench 386-165 \$31.95

Tire Irons

A close match to those in early tool kits.

387-008 \$16.95



Long Handle Knock-Off Wrench

Long handle wrench allows you to tighten or remove octagon spinners without a hammer.

For Safety Knockoffs 386-120 \$48.95

For Eared Knockoffs 386-125 48.95

Fabric Wrench Cover 386-115 15.95



A16 | Performance

INTAKE & EXHAUST

Performance Header | 01



Stainless Steel Exhaust | 02



Weber DCOE Soft Mount Kit | 04

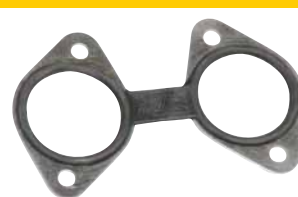

(04) Weber DCOE Soft Mount Kit

Vibration plays havoc with fuel level, so any Weber DCOE installation works better when the carburetor is isolated from the manifold. This kit solves the problem and following up on customer requests we now have it in stock.

Weber Soft Mount Kit 222-251 \$32.95

Free Flow Exhaust Midget 1500 | 05

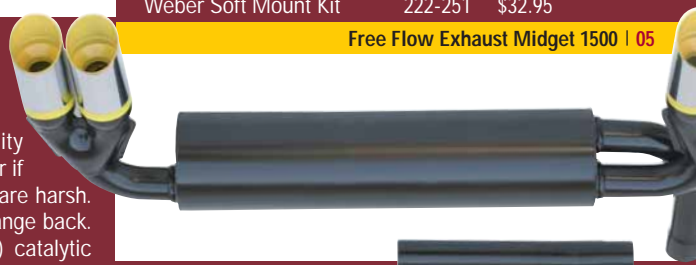

Stainless Steel Exhaust System (02)

Constructed entirely of top-quality stainless steel, ideal system for your car if you live where winter road conditions are harsh. Includes all pipes from the manifold flange back. Clamps, hangers and (when required) catalytic converters not included. Life guaranteed against corrosion only.

948cc	452-000	\$205.95
1098	452-010	205.95
1275 ('67-'68)	452-010	205.95
1275 ('69-'72)	452-015	205.95
1275 ('73-'74)	452-025	285.95
Midget 1500**	452-030	292.95

(01) Performance Exhaust Headers

These tubular exhaust headers are suitable for vintage racing or the sporting enthusiast. All headers are jig-welded and designed for maximum performance. Hand fitting and port matching required, particularly for racing applications.

Spridget 948cc	452-060	\$295.95
Spridget 1098/1275cc	452-065	328.95
Midget 1500cc*	452-070	340.95

*not suitable for use with stock water choke manifold.



New SU Carburetor Sets

Genuine SU carburetors produced in the UK from new and original tooling.

Sprite MkII, Midget MkI	370-708	\$569.95
Spridget 1098, '63-'66	370-718	569.95
Spridget 1275, '67	370-728	589.95
Spridget 1275, '68-'69	370-908	569.95
Spridget 1275, '69-'71	370-928	569.95
Spridget 1275, '72-'74	370-948	569.95

Double Ended Fuel Pump | 03



(03) Double Ended Fuel Pump

Double-ended SU pumps have been standard equipment for years on Aston Martins, Bentley and late model E-Types. Delivering twice the capacity of a standard type pump, these units will keep on pumping even if one side fails. Well-suited for all high performance engines running SU carbs, as no pressure regulator is required.

Standard Points

Positive Ground	377-045	\$362.95
Negative Ground	377-035	362.95

Solid State

Positive Ground	377-345	\$384.95
Negative Ground	377-335	393.95

★ Amendments to the Clean Air Act make it illegal for anyone to change or alter the emission control system of any automobile in the United States except cars used exclusively off-road.

(05) Free-Flow Exhaust System

Increases both horsepower and gas mileage by reducing exhaust gas back-pressure. Heavy gauge steel, black with chrome-tipped ends. Front down pipe not included.

Sprite/Midget 1275	452-040	\$149.95
Midget 1500	452-050	229.95

Solid State Fuel Pump

Solid State Electronic Fuel Pumps can be used in conjunction with, or in place of your original pump. The solid state pump will push or pull fuel from a hidden location under the car, through your original pump, or put it in line with a power switch and use it as a backup. Works on positive or negative ground cars.

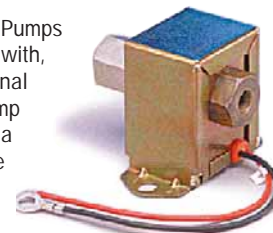

377-420 \$99.95

SU Solid State Fuel Pump

New from SU electric fuel pumps with modern reliable electronic, solid state switching and control which eliminates the use of contact breaker points. Now you can have a vintage looking SU fuel pump with peace of mind that only an electronic fuel pump can offer. Plus the characteristic ticking is retained.

Negative ground	377-225	\$196.95
Positive ground	377-235	184.95



Performance | A17

INTAKE & EXHAUST



Weber Side Draft Conversion | 06

Due to the worldwide shortage of Weber carburetors please call for availability. Prices may fluctuate from those published.

(06) Weber DCOE Conversion *

High performance DCOE carburetors are still the enthusiasts choice to extract maximum power. The kit includes manifold, linkage and carburetor with ram pipes. Re-jetting and venturi changes may be necessary. We recommend that tuning be performed by an experienced tuner. Please note that there is no provision for emission connections and some modification will be required for best operation.

Sprite/Midget 948/1098			
Single 40DCOE	222-440	\$799.95	
Sprite/Midget 1275			
Single 45DCOE	222-450	799.95	
K&N Air Filter (1-3/4" deep)	222-245	64.95	
K&N Air Filter (3" deep)	222-240	84.95	



Weber Conversion | 08

Due to the worldwide shortage of Weber carburetors please call for availability. Prices may fluctuate from those published.



Stellings & Hellings | 07

(07) Stellings & Hellings Style Air Filters

Ultra-thin design beautifully plated.
Filter for 1 1/4" SUs 223-100 \$31.95 ea.



Foam Air Filters

The traditional performance washable foam filters.

Round for 1 1/4" S.U.	223-260	\$36.95
Oval for Midget 1500	223-280	39.95

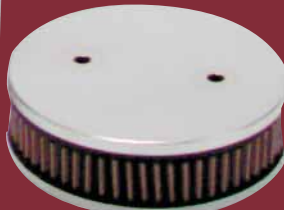

K&N Air Filters

K&N air filters are designed to be washed and reused for the life of your engine. Ten year K&N warranty or one million miles (non-comp. use).

Flat Chrome Assembly for Zenith-Stromberg			
1 3/4" deep	222-925	\$74.95 ea.	
Chrome K&N Filter Assemblies Weber DCOE			
1 3/4" deep	222-245	\$64.95 ea.	
3" deep	222-240	84.95 ea.	
Chrome K&N Filter Assembly Weber DGAV			
1 3/4" deep	222-366	\$62.45 ea.	
K&N Air Filter Elements For Stock Applications			
Spridget HS2	373-435	\$40.95 ea.	
Filter Cleaning Fluid	231-480	9.95 ea.	
Filter Oil Bottle (250ml)	231-490	5.80 ea.	



Billet Fuel Filter Kit

The ease of cleaning and clean lines of this filter assembly will add a touch of custom brightness to the engine compartment. The chromed hose barbs can be removed and 5/16" AN-6 fittings attached directly to the body of the fuel filter giving a high degree of fitment flexibility.

377-305 \$44.95

(08) Weber Downdraft Carb Kits *

The Weber DGV two barrel progressive carburetor has proven to be the most popular replacement for worn out or damaged stock carburetors and gives a good combination of performance and economy on stock engines. Kits include instructions, carburetor(s), manifold/adapters, linkage & air filter(s). Please note that there is no provision for emission connections and some modifications will be required for best operation.

Spridget 1275cc	222-275	\$579.95
Midget 1500 (Water Auto. Choke)	222-255	579.95
Midget 1500 (Electric Auto. Choke)	222-256	579.95
Midget 1500 (Manual Choke)	222-257	579.95
Chrome Filter Ass'y	222-365	37.95
K&N Air Filter Ass'y	222-366	62.45
Carburetor Rebuild Kit	222-266	74.95

Short Ram Pipes | 09 **Long Ram Pipes | 10**



Ram Pipe Sets

A racing tradition, now available in long (3") and short (1 1/4"). Set of two. Check with your salesperson if you are unsure which carburetor you have. For 1 1/4" Carburetors.

(09) Short	372-425	\$44.95 pair
(10) Long	372-405	\$44.95 pair



MG Crested Carburetor Caps

These very distinctive solid brass caps make any engine compartment unique! Your original damper rod must be reused and pressed into the new cap.

Dashpot Caps (pair)	370-735	\$20.95
Float Bowl Cap	370-135	11.95



Manual Choke Conversion Kit *

Designed in England by Zenith-Stromberg. Includes all mounting hardware, indicator light, and detailed instructions. Easy installation.*
 Midget 1500 386-325 \$124.95



A18 | Performance ENGINE

Alloy Cylinder Head | 01



(01) 1275 A-Series Alloy Cylinder Head

Light-weight (9 lbs.) high strength aluminum alloy cylinder heads run cooler, allow higher compression ratios, and have a greater than 35% increase in flow rate. Includes silicon-bronze valve guides and hardened valve seats. Requires 1275 valves, springs, retainers, and 12mm spark plugs (use NGK #NCP7E or Champion #RA8HC) not included. Quantities required are in parentheses. These heads do not have air injection ports, and therefore may not be used for street use on cars originally fitted with air pumps.

Alloy Cylinder Head	451-875	\$1,049.95
Intake Valve (4)	423-190	8.95
Exhaust Valve (4)	423-335	14.95
Valve Spring Set (1)	423-470	22.95
Valve Cotter (16)	460-535	4.45
NGK Spark Plug (4)	451-890	3.95



Magnetic Oil Drain Plugs

Magnetic drain plugs help protect your engine by collecting metallic particles before they get fed through the oil system.

948-1098-1275	328-282	\$4.95
Midget 1500	328-356	3.25



Hardness Tested Tappets

To ensure the highest quality product, we test each tappet for hardness and dimensions. The wear surfaces are then profiled and a matched set packaged with cam lubricant.

Tested Tappet Set	460-604	\$159.95
-------------------	---------	----------

Alloy Valve Cover | 02



(02) Alloy Valve Covers

'61-'74 Polished Ribbed Cover	224-530	\$73.95
Midget 1500 Polished Ribbed Cover	224-550	92.95
Midget 1500 Black Ribbed Cover	224-560	139.95
Replacement Chrome Cap	460-145	13.95

Performance | A19

ENGINE

Spin-On Adapter | 03

K&N Oil Filter | 04

Competition Gaskets | 05

Head Gaskets | 06



(03) Spin-On Oil Filter Adapters

Cleaner oil changes will result if you change your engine from the messy original canister filter to a modern spin-on filter. Each kit includes all necessary pieces for installation, filter not included.

Adapter (not 1500)	235-875	\$98.95
Spin-On Filter	235-880	5.95
Spin-On Filter - Wix	235-855	11.95
Spin-On Filter - K&N	235-830	13.95

(04) K & N Performance Oil Filter

K&N Filter technology is the leader for your spin-on oil filter conversion. Over 550 psi hydrostatic burst strength counters sluggish performance and reduces the risk of damage. Resin impregnated filter element traps even the tiniest contaminants and isn't affected by racing fuels. Featuring heavy-duty construction with metal endcaps, anti-drainback valve and a 1" safety wire drilled wrench nut; this is the best on the market.

235-830 \$13.95

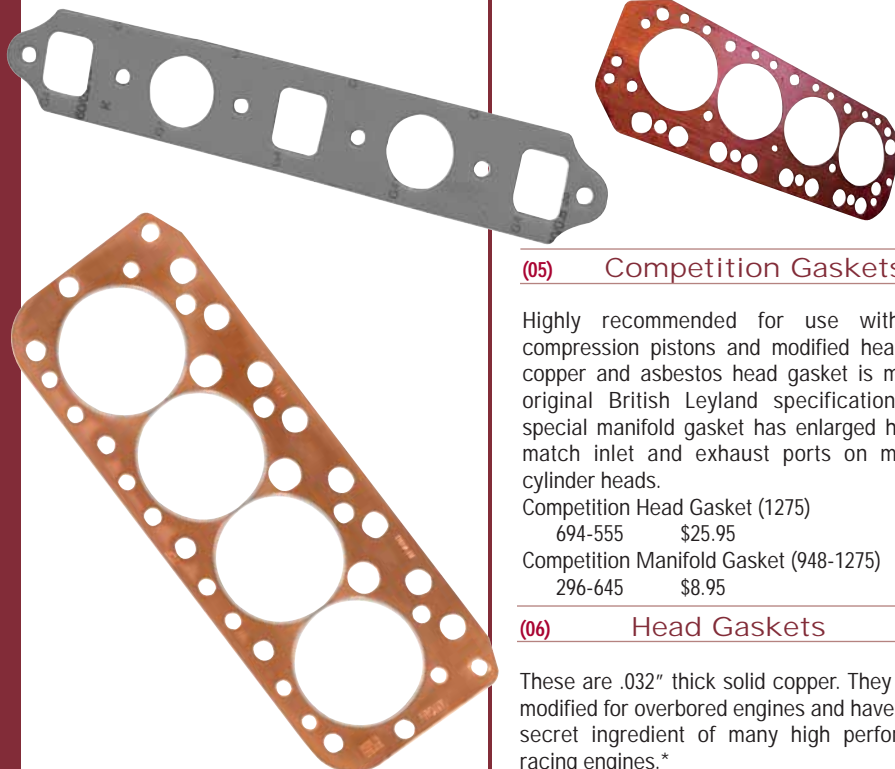

(05) Competition Gaskets

Highly recommended for use with high compression pistons and modified heads, the copper and asbestos head gasket is made to original British Leyland specifications. The special manifold gasket has enlarged holes to match inlet and exhaust ports on modified cylinder heads.

Competition Head Gasket (1275)	694-555	\$25.95
Competition Manifold Gasket (948-1275)	296-645	\$8.95

(06) Head Gaskets

These are .032" thick solid copper. They can be modified for overbored engines and have been a secret ingredient of many high performance racing engines.*

948 & 1098cc	387-515	\$74.95
1275cc	387-520	74.95
Copper Gasket Sealant		
16oz Aerosol	387-501	15.00

*Copper head gaskets are not recommended for use with alloy heads.



ARP High Performance Fastener Kits

Manufactured from top grade 8740 Chrome Moly Steel. Tensile strength in the range of 200,000 psi. Threads rolled after heat treat to provide up to 10 times longer fatigue strength. Precision CNC machined to exacting specifications.

1275 cc Head & Rocker Stud Kit (11 stud)	322-998	\$208.95
1275cc Rod Bolt Kit	322-838	141.95
1275cc Main Stud Kit (exc. Cooper S)	322-888	94.95



Flywheel Assembly

For quicker response and improved performance, our alloy flywheel assembly is the racers choice. These lightened flywheels feature a replaceable steel face with a mechanically located ring gear. Spridget 1275

461-005 \$549.95



Vernier Cam Gear Kit

If you're serious about your engine rebuild, this is one upgrade you should be sure to install! Our kit includes the double row chain, along with fully adjustable cam sprockets.

948-1098-1275 460-385 \$299.95



A20|Performance

BATTERY & COOLING

Optima Battery & Tar Topper | 01



Tar Top | 02



Battery Switches | 03

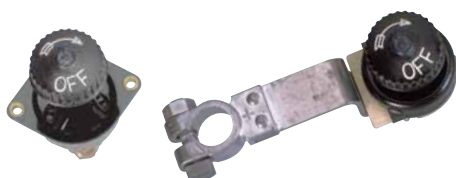

(01) Optima Battery

The Optima battery never needs water, won't leak causing damaged paintwork, and has a cold cranking capacity much higher than conventional batteries. If you want modern battery technology, but prefer a more vintage look, the Tar Topper designed specifically for the Optima is the answer.

Optima Battery	459-405	\$197.95
Tar Topper	241-035	36.95

(02) Classic Tar Top Batteries

Our UK-made tar top batteries were fitted as original equipment to many British sports cars. An original looking battery. Shipped dry. Battery acid should be purchased locally.

12-Volt Battery	459-480	\$200.95
-----------------	---------	----------

(03) Battery Switches

Genuine Lucas battery cut-off switches simplify servicing and long term auto storage. A strategically placed remote switch deters theft.

Remote Switch	145-770	\$125.95
Neg. Post Mount	145-780	169.95

Battery Tray Liner

Tough, corrosion-proof battery tray liner protects precious sheet metal.

	241-020	\$49.95
--	---------	---------

Battery Cut-Off | 04



(04) Battery Cut-Off Switch

Quickly and effectively disconnects your battery for servicing or long term storage. Sized for negative posts.

	145-795	\$12.95
--	---------	---------

(05) Quick Bolt Set

Quick Bolts have a camming system to clamp down on battery posts. Simply replace the bolts in your cable ends with Quick Bolts and you can connect or remove the cables without tools.

Quick Bolt Set	900-015	\$13.50
----------------	---------	---------

(06) Alternator Fan

Moss Exclusive. No longer available from Lucas, we have tooled up to keep this item available.

	130-400	\$24.95
--	---------	---------

(07) 6 Blade Plastic Cooling Fan

Back in production by British Motor Heritage, you now have a chance to replace your damaged or missing original fan blade.

Cooling Fan Sprite/Midget -74	434-560	\$41.95
-------------------------------	---------	---------

Racing Battery Switch



Primarily intended for competition use, this rugged switch can be used on any car. The removable key deters theft. Attached rubber cap keeps dirt and water out when the key is removed. Meets FIA requirements for motor sport.

	145-785	\$85.95
--	---------	---------

Battery Acid Neutralizing Mat

Made from a special acid absorbent material which neutralizes acids as they leak from your battery. Easily cut with scissors to match the shape of any battery or tray.

	241-025	\$6.95
--	---------	--------



PriorityStart | 11



Alternator Fan | 06



6 Blade Plastic | 07



Failsafe Thermostat | 08



Hayden Electric Fan | 09



Thermostat Sleeve | 10



(09) Hayden Electric Fans

May be set up to run in either "pusher" (in front of the radiator) or "puller" configuration. The 10" fan requires a clear mounting area of at least 10 5/8" x 11 1/8", while the 12" requires at least 11 1/2" x 12 1/2". The preset temperature control will turn the fan on at 185°F and off at 170°F.

10" Electric Fan Kit	231-678	\$129.95
12" Electric Fan Kit	231-688	139.95
14" Electric Fan Kit	231-658	149.95

(08) Failsafe Thermostat

Manufactured from high-grade stainless steel and copper, this thermostat locks open during overheating for added safety.

180° Thermostat	434-205	\$15.95
-----------------	---------	---------

(10) Thermostat Blanking Sleeve

For maximum power and speed, such as racing conditions, it is advantageous to remove the thermostat, but only when this thermostat bypass blanking sleeve is fitted.

Blanking Sleeve	434-135	\$22.95
-----------------	---------	---------

(11) PriorityStart

PriorityStart automatic starting protector monitors battery voltage. If there is a drain taking place, it automatically disconnects the battery, leaving enough voltage to start the vehicle. The unit senses the ignition key in the "on" position and automatically reconnects the load.

	459-350	\$84.95
--	---------	---------

Performance | A21 IGNITION

Crane Electronic Ignition | 12



(12) Crane XR-700 Electronic Ignition

Expect faster starts, cleaner running and better performance at all engine speeds.
 For point-type dist. 222-680 \$130.95
 For Lucas elec. dist. 222-325 128.95

Race Distributor | 15



Mallory Distributor | 16



(16) Mallory Distributors

Unilite Electronic Distributor

Self contained rugged photo-optic trigger and adjustable mechanical advance. Simple three wire hookup. Shaft must be drilled for drive dog (not included). Negative ground only.
 4-Cylinder Distributor 143-155 \$524.95

Mallory Dual Point Distributor

These distributors can be tailored to suit any engine tune. The Mallory dual point distributor is particularly well suited for Weber carb installations. Shaft must be drilled for drive dog (not included). 143-180 \$280.95

Ignition Wires | 17

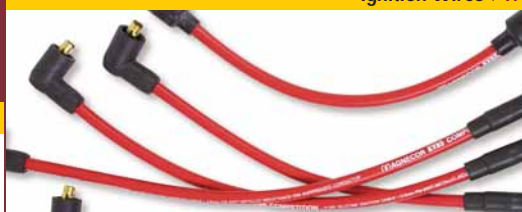

(15) Race Distributor

A more original looking alternative to the Mallory dual point distributor. This points-type distributor has an advance curve designed for use with long duration race cams. Centrifugal advance only, for the serious racer. Uses 153-915 point set, 151-855 rotor and 151-875 cap.

Race Distributor	143-165	\$329.95
Replacement Points	153-915	7.00
Replacement Rotor	151-855	33.50
Replacement Cap	151-875	13.95

(17) Performance Plug Wires

Magnecor competition spark plug cable sets work great on street cars with either conventional or electronic ignition systems. Low resistance, yet also shielded to reduce radio noise interference.
 1500 Midget 143-556 \$39.95

Crane IgnitionCoil | 13

Lucas Sport Coil | 14



(13) Crane Ignition Coil

The "nickel plated" PS40 coil complements the Crane XR-700 electronic ignition kit. Includes a ballast resistor. 143-240 \$58.95

(14) Lucas Sports Coil

40,000 volt output gives more starting power, and greater performance at high rpm. Works with non-ballasted ignition systems only. 143-200 \$46.95



Petronix Ignitor II for Mallory Dual Point Distributors

We now carry a Pertronix Ignitor system designed to retrofit 4 cylinder Mallory Dual Point Distributors. Offers the longevity of the Mallory distributor with the ease and accuracy of electronic ignition. 143-181 \$124.95



Pertronix Second Strike Ignition System & Rev Limiter

Two sparks are better than one. This box adds a hot second spark to your ignition system to improve burning, power and efficiency. To keep the extra power under control the unit includes a Digital Rev Limiter. Fits all 12 V Negative Ground. Ignition System 222-625 \$374.95

Pertronix Digital Rev Limiter

If you are autocrossing or racing, this unit is essential to prevent over-revving and engine damage. A 4-wire hookup and the rev limiter's small size (2.5" x 3.0" x 1.4") make installation and fitment in many locations within the engine compartment easy. Fits all 12 V Negative Ground. Rev Limiter 222-635 \$159.25

Pertronix Electronic Ignition

- No external control boxes to mount.
- No points to set or change.
- Hall effect sensor is impervious to dirt, or moisture & retains stock advance curve.
- Locate Lucas model number stamped in housing by the vacuum advance.
- 30 month manufacturer's warranty.

Points Type- Negative Ground, 25D 222-405 \$110.95

Points Type- Positive Ground, 25D 222-555 127.95

1500 with "Opus" electronic Ignition, 45DE4 222-425 110.95

1500 with "CEI" electronic Ignition, 45DM4 222-475 110.95

Pertronix Ignition Coil

Matched to the Ignitor ignition. Ballasted ignition system was used from 1975 on.
 Non-ballasted systems 143-265 \$43.60
 Ballasted systems 143-270 43.60



Universal Coil Mounting Bracket

Replace missing, bent or corroded coil brackets. Also useful if you are upgrading or relocating the coil. 143-255 \$3.95

Bumblebee Ignition Wire

This type of distinctive competition wire was a very popular performance accessory with the BMC/BL Competitions Department from the 50s to the 70s. Sold per foot. 571-020 \$3.25

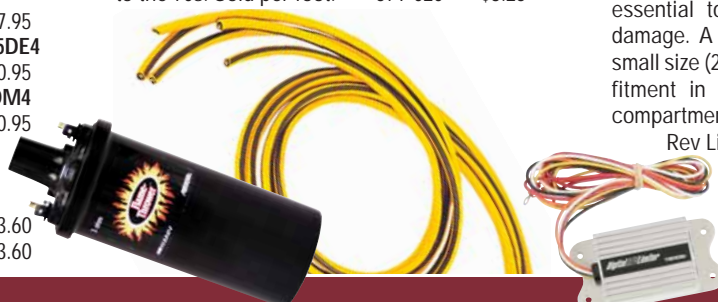

A22 | Performance

BRACING

High Performance Front Disc Brake Pads

(01) EBC "Green Stuff" Brake Pads

Made in the UK for "fast road" use. Kevlar brake pads for improved stopping, reduced fade and dusting. 585-625 \$64.95

(02) Hawk Brake Pads

Designed for the serious street and autocross enthusiast these pads are at home on both the track and street. Note due to the increased friction levels, brake life may be decreased. 585-605 \$64.95

(03) Semi-Metallic Brake Pads

These special brake pad sets provide excellent overall braking performance and give you smooth straight stops from even the highest speeds. Guaranteed not to dust, squeal or fade, they typically last three to five times longer than ordinary pads. 071-537 \$40.95



Braided Stainless Steel/Teflon Brake Hose Sets

These competition-inspired brake hose sets meet all DOT safety standards and are street legal in all 50 states. Each set includes all brake hoses used on your car, with any required retaining nuts and/or copper sealing washers.

With front drum brakes	182-198	\$96.95
With front disc brakes	182-248	96.95

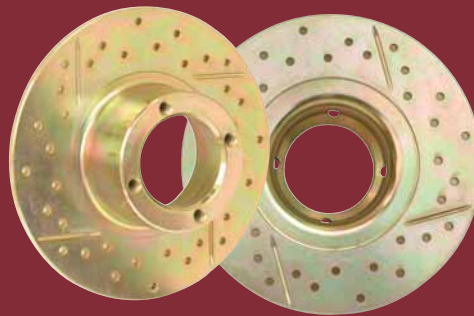

Cross-Drilled & Slotted Rotors

Get the stopping power you need with a Moss Motors exclusive. Cross-drilled holes lower brake temperatures and reduce rotational mass and out-gassing, while slots allow excess water, dirt and dust to dissipate. Sold as a pair. Disc wheels only 586-600 \$198.95

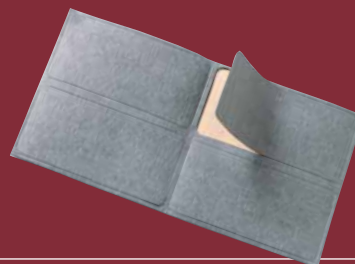

Disc Brake Anti-Squeal Strips

These foil-lined self adhesive strips fit between the pad and the piston to eliminate vibrations that cause brake squeal. Set of four. 583-805 \$5.45



Mud Flaps

Durable, heavy duty mud flaps. Fits front or rear wheel arches. Set of two includes mounting hardware.

Midget Logo Flaps	222-630	\$18.95
Sprite Logo Flaps	222-620	18.95



Brake Caliper Paint System

Make your Brake Calipers look as special as the rest of your car. In a couple of hours, your calipers can have the same colorful high gloss luster found on very expensive German Sports cars. The paint has an industry leading heat resistant capability of 9000° F. Kits come complete with the following: 2 component high tech paint system, 1 can of brake caliper cleaner, 1 mixing cup, 1 application brush.

Ground Shipping Only.

Red	216-800	\$33.95
Yellow	216-801	33.95
Blue	216-802	33.95
Silver	216-803	33.95
Black	216-804	33.95
Purple	216-805	33.95
White	216-806	33.95
Green	216-807	33.95
Gold	216-808	33.95

NEW COLORS AVAILABLE

Performance | A23

SUSPENSION

Lowered Front Springs | 05



Front Anti Sway Bar | 06



(06) 3/4" Anti Sway Bar

The 3/4" anti sway bar is an excellent compromise for both fast road, and competition use. Increased front sway bar diameter reduces body roll and understeer which in turn gives better handling control. Use with solid mounts below. 264-555 \$170.95

Solid Sway Bar Mounts



Machined aluminum mounts may be employed for road use, but were primarily designed for competition purposes. Some increase in road noise can be expected. Use with 3/4" bars. Sold as a pair. 263-435 \$80.95

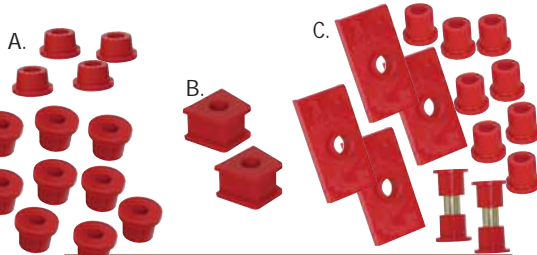

Prothane Bushings

Superb engineering design details differentiate these from other poly-urethane replacement bushings. Grooved bores in some bushings to hold a special Teflon grease make these bushing sets long-lasting and quiet (included).

- A. Front Suspension Kit includes upper and lower bushings. 280-938 \$32.95
- B. 9/16" Sway Bar Mount Kit. 280-935 11.95
- C. Rear Spring Kit (1/2 elliptic spring cars only) Kit includes front and rear eye bushings and mounting pads. 266-418 56.95

(07) Roll Bar

Our bolt-in roll bar looks great and causes minimum restriction of cockpit space. They're even designed to fit inside the convertible top. The optional pad is vinyl covered and uses snaps and velcro fasteners to keep it firmly in place. Includes mounting hardware.

1961-'69 Spridget Roll Bar	453-325	\$379.95
Roll Bar Cover	236-000	97.30

Competition Front Springs

For serious competition, we recommend this 400 lb. spring rate front coil spring. Lowers standard ride height by 1". Fits chrome bumper cars. Available on special order only. Please allow 6 to 8 weeks for delivery.

Competition Spring	264-615	\$69.95
--------------------	---------	---------

(05) Lowered Front Coil Springs

For chrome bumpered cars, this spring slightly lowers the ride height while providing a useful increase in spring rate to 340 lbs./in.

Lowered Spring	264-605	\$77.95
----------------	---------	---------



Front Suspension Lowering Kit

This kit contains special spacers which install between the wishbone/spring pan and the spring seat to lower your front suspension one half inch. Works with all springs. Kit includes spacers and bolts for both sides. 264-665 \$23.95



Limited Slip Differentials

Quaife gear type limited slip differentials deliver more engine power to the ground. Great for racing, auto-crossing, driving in the snow or just for fun. Installation requires no more work than rebuilding a standard differential.

Sprite/Midget	267-075	\$1,708.95
---------------	---------	------------



Nylatron Upper Trunnion Bushes

Nylatron bushings firmly locate your front suspension. Standard camber trunnion bushings are a direct replacement for your original bushings. The negative camber bushings are designed primarily for competition purposes and give improved steering and braking control. Sold individually, 4 required per car.

Standard Camber Bushing	264-585	\$12.95
Negative Camber Bushing	264-595	14.95

Roll Bar | 07



Tube Shock Conversion | 08



(08) Rear Tube Shock Conversion

These kits contain the Spax adjustable gas filled shocks (adjustable from the outside). Includes new lower spring plates that incorporate an angled mounting flange. Installation is easy and instruction are included.

1959 to 1964	264-674	\$491.95
1964 to '74	264-675	491.95
1975 on	264-676	469.95



Lowered Rear Springs

Significant gains in cornering ability can be achieved with lowered rear springs. Sold each.

1964-'74 Rear Spring 1" Lower	264-685	\$146.95
1964-'74 Rear Spring 2" Lower	264-705	\$202.95 ea.

Aston Gas Cap

Features include quick release and easy installation. This polished aluminum Aston gas cap is theft proof. Fits to '69. 407-125 \$159.95



Locking Gas Cap



Chrome locking fuel filler cap. Includes two keys. Fits to '69. 202-760 \$20.95



A24|Books & MANUALS



(12) Restoring Sprite & Midgets

Written with technical expertise and wit, this manual is packed with photos and illustrations covering all aspects of restoration.
213-305 \$44.95

(13) Owner's Manual Reprints

Reprints of the manuals originally supplied with your car. From basic tuning and maintenance, to putting up the top. An essential book for your library.

Bugeye Sprite	212-690	\$19.95
Midget MkIII	212-705	18.95
Midget 1975-'78	213-310	19.95
Midget 1979-'80	213-320	19.95

(14) SU Power Tuning Book

Des Hammill demystifies fuel-delivery secrets in this 63-page manual. Its expert tips can make you a master at modifying and tuning SU carburetors. Includes coverage of needle reprofiling for custom applications.
211-465 \$24.95

(15) Sprite & Midget

By Jonathan Edwards. Technical detail, model history showing all the major variations. Invaluable to ensure originality and accuracy.
211-595 \$24.95

Glovebox Workshop Manuals

These manuals are packed with information. Tune up data, repair and rebuilding information, dimensions and torque specs are in these compact 5 1/2" x 8 1/2" books. For all 1958-'80. 212-480 \$29.95



(01) Tuning A Series Engines

By David Vizard. This is the Bible for anyone wanting to improve their A Series Engine, be it for performance or economy. Covering every area of the engine, from crank to valve guides, with examples of modifications. 488 pages.
212-160 \$44.95

Haynes Workshop Manuals

An excellent guide to tune up and maintenance of SU, Zenith-Stromberg and Weber carbs.

(02) Carb Manual	211-430	\$18.95
(03) Sprite-Midget	212-380	18.95

(04) Bosch Automotive Handbook

Packed full of facts and figures in a very compact format. Guaranteed to improve your automotive IQ with general coverage of all areas of engine and vehicle operation. Fifth Edition, 962 pages, softbound.
212-155 \$69.95

(05) SU Carb Rebuild Video

Tune or rebuild SU carbs with this easy-to-follow 2 hour 40 minute video. VHS format.
211-035 \$39.95

(06) Factory Workshop Manual Reprints

Everything from basic tuning data, to torque settings and complete component rebuilding.

Bugeye Sprite	212-465	\$63.95
Sprite MkII on/Midget to '74	212-475	68.95
Midget 1500	212-415	52.95

(07) Lucas Fault Diagnosis

For professional technicians, easily understood by the non-professional. Softbound, 8 1/2" x 11", 46 pages. 990-035 \$7.95

(08) Component Restoration

Fuel Pump on the blink? Generator not generating? This book covers in-depth rebuilding of typical components: major electrical items, fuel components, heaters and instruments.
215-875 \$29.95

(09) Weber Carburetors

By Pat Braden. How to select and tune Weber sidedraft and downdraft carburetors. Soft-bound, 8" x 10", 300 pages.
213-430 \$20.95

(10) Guide to British Sports Cars

Have you ever wondered what a Jowett Jupiter looked like? Improve your knowledge of the British Sports Cars that were exported to the US. Find out the difference between a Morgan +4 and 4/4. 224 pages, very well illustrated.
213-815 \$24.95

(11) SU Workshop Manual

Factory workshop manual for SU carburetors and fuel pumps. 211-305 \$26.70

Car Care | A25

& MAINTENANCE

Auto Ref | 17



DVD: 50 Years | 18



DVD: MGs | 19



Jigsaw Puzzle | 20



Super Chamois | 01



Cam & Lifter | 02



Water Repellent Kit | 06



(17) AutoRef

AutoRef gives you information, including, but not limited to; charts; driving and accident helps; safety information; personal information about your car...everything you can think of that might be useful when you are in your vehicle. There is no other book like this one. Sample of Contents: Maintenance Logs, Maintenance Charts, Maps for every State & Canadian province, Tire Sizes/Ratings, Lubricants, Electrical System Diagnostics, Dashboard Symbols, Towing Charts, Mileage Charts, Accident Safety, Engine Information, Weather, Automotive Math, General Information, Conversion Factors & Tables, Much More! 5 3/8" x 3 1/4" 672 Pages.
210-320 \$12.95

(18) DVD: 50 years of British Racing in the US

Rare footage showing the history of British Sports Car racing in the U.S. Starting with the Collier Cup in New York to the popularity of vintage racing today. Approximate length: 70 minutes.
211-092 \$29.95

(19) DVD: MGs Across America

A must have for any MG video library. See how the British view our cars and hobby. Features early race footage, TV advertising, shows and a comparison between US and UK spec. MGs. Approximate length: 100 minutes.
211-090 \$29.95

(20) Jigsaw Puzzles

Great for gifts, or for those long winter evenings when it is too cold for driving or fiddling with the car. 308 pieces.
Bugeye 214-405 \$19.95
Sprite/Midget 214-430 19.95

SU Tuning Tips & Techniques

By G. R. Wade. Factory information to help you solve all standard SU problems.
211-345 \$29.95



Copaslip | 03



Lead Substitute | 04



Muffler Sealant | 05



(01) Super Absorbent Chamois

Our giant six square foot chamois really soaks up water, and it won't harm delicate paint finishes.
386-945 \$34.95

(02) Cam & Lifter Break-In Protection

Super Lube Break-in concentrate is an anti-wear additive formulated with a high concentration of special zinc dithiophosphate to provide sustained protection against cam lobe and lifter scuffing and wear. Should be used for the initial break-in period ONLY. Most current oils have severely reduced this zinc content leading to elevated stresses where rubbing occurs and therefore potential premature cam lobe and lifter failure.
221-430 \$9.95

(03) Copaslip Anti-sieze Compound

This anti-sieze is highly recommended for wire- wheel splines and knockoff threads. The Molybdenum formulation reduces galling and corrosion to improve the life of wire wheels and hubs. Wheel and hub surfaces should be cleaned and relubricated at least once per year as part of a regular maintenance program.
57g (2oz) Tube 221-405 \$7.95
250g (8.8oz) 221-410 16.95

(04) Lead Substitute With Octane Booster

Effective valve and valve seat protection plus a powerful octane booster that will raise octane rating by as much as 5 points depending on the type of gasoline.
220-365 \$3.25

(06) Water Repellent Kit

Created by the makers of the original windshield water repellent, this amazing glass cleaner and water repellent kit seals auto glass with a super smooth invisible barrier that repels rain, sleet and snow on contact. Dirt, road grime and insects can't stick, letting your wipers push them aside. Kit includes 10 oz bottle of glass cleanser that strips away built up dirt, insects, salt, wax, tree sap, and road grime without scratching; and 5 oz bottle of super concentrated water repellent gel that seals the glass for weeks at a time.

Kit	221-528	\$12.50
Glass Scrub	221-520	5.25
Rain Clear	221-525	7.25

(05) Muffler and Tailpipe Sealant

Improves joint sealing and eases fitting of exhaust components.
221-545 \$2.95



Mr. Moly Lubrication Products

Liquid Grease Spray
High quality liquid grease in a spray can with molybdenum disulfide. Suitable for lubricating door locks and hinges. No air shipping.
Liquid Grease Spray 221-415 \$11.95

Engine Oil Supplement
A suspension of Molybdenum Disulfide provides a friction reducing barrier able to withstand extreme pressures. Will not clog filter or passageways. Works with all motor oil including synthetics. DO NOT use during engine break in.
Engine Oil Supplement 221-420 \$11.95

Transmission Supplement
Molybdenum Disulfide manual transmission supplement reduces friction to reduce wear and heat in gearboxes and differentials. Do not use in automatic transmissions or limited slip differentials.
Transmission Supplement 221-425 \$16.95

A26 | Car Care & MAINTENANCE

AutoGlym Car Care | 01



Renovo Soft Top Care | 02



(02) Renovo Soft Top Care

The best care you can give to your fabric or vinyl convertible top. Water based Renovo products clean, waterproof and revive tired tops safely.

Fabric Top Dry Cleaner	220-260	\$20.95
Water & Stain Proofer	1 L	220-265 35.95
	500 ML	220-280 21.95
Vinyl Top Cleaner	500 ML	220-285 16.95
Vinyl Top Protector	500 ML	220-290 16.95
Plastic Window Polish	100 ML	220-255 26.95
Plastic Window Polish	30 ML	220-275 9.90
Black Fabric Top Reviver	1 L	220-250 57.95
Black Fabric Top Reviver	500 ML	220-270 29.95
Blue Fabric Top Reviver	1 L	220-295 57.95
Blue Fabric Top Reviver	500 ML	220-300 29.95
Brown Fabric Top Reviver	1 L	220-305 57.95
Brown Fabric Top Reviver	500 ML	220-310 29.95

Luster Care Products

Polish & protect every metal surface on your car. Lace and pads reach hard to get places.



Combo Kit of polish impregnated lace and pads	220-230	\$12.95
Luster Pad 5" x 3/4" impregnated wad	220-235	10.95
Luster Seal, 8 fl oz bottle to seal in shine	220-240	10.95

(01) AutoGlym Car Care

For over 30 years Autoglym of England has been producing award winning shine on many of the world's finest automobiles.

Used by such companies as Jaguar and Aston Martin for Motorshow preparation. Moss is proud to introduce a full line of Autoglym car care products.



Super Resin Polish	220-950	\$13.95
Car Exterior Shampoo	220-951	10.40
Car Interior Shampoo	220-952	10.35
Glass Polish	220-953	10.40
Metal Polish	220-954	10.35
Vinyl & Rubber Cream	220-955	13.95
Wheel Cleaner	220-956	12.95
Leather Care Cream	220-957	10.40
Engine Cleaner	220-958	13.95
Cutting Polish	220-959	10.45
Extra Gloss Polish	220-960	15.95
Plastic Restorer	220-961	12.95
Instant Tire Dressing	220-962	12.95
Perfect Polishing Cloth	220-963	12.95

Microfiber Cloth

Microfiber towel is made from a blend of Polyester and Polyamide. The small fibers pick up and absorb dust, dirt and grease, then releases it when washed. Cloth can hold up to 7 times its weight.



Includes 3 towels.

231-675 \$14.95



Wire Wheel Brush

If your car has wire wheels, you need this brush! Shaped to get around the spokes without damaging your knuckles, this heavy-duty brush makes wire wheel cleaning a snap.

Wire Wheel Brush 386-940 \$7.95



Professional Car Duster

100% cotton dusting mop is treated with special wax to trap dust. Simply shake it out and it's ready to use again. 20" long. Comes with a protective carrying case.

231-670 \$16.95

Mini Car Duster



Wax treated cotton fibers lift dust off surfaces. Simply shake the dust out after every use. Will not scratch finish.

231-671 \$7.95

Kozac Dry Wash | 03



(03) Kozac Dry Wash Cloth

Kozac's specially treated long cotton fibers are woven into a thick plush nap, which draws dust up away from your paint. Cleans without water.

231-620 \$11.95

Novus Plastic Polish | 04



(04) Novus Plastic Polish

Bottle #1 cleans and polishes plastics. Bottle #2 restores the original appearance of plastics. Bottle #3 removes heavy scratches and abrasions from acrylic surfaces. Final finishing requires Novus #2.

#1 Plastic Polish	220-605	\$5.95
#2 Plastic Polish	220-610	6.95
#3 Plastic Polish	220-615	8.95

8 fl. oz. bottles.

Rain-X



Will not damage wiper blades. Rain-X Anti Fog treats windows, mirrors, goggles and any other nonabsorbent surface.

Rain-X	221-550	\$6.95
Anti Fog	221-575	6.50

Convertible Top Maintenance

The only top cleaning & protection system endorsed by Haartz. Recommended by Doug Robbins of Robbins Autotop. Keep your convertible top clean and protected, so it will last longer and stay new looking.



Top Cleaner	221-505	\$8.95
Fabric Protectant	221-510	14.95
Vinyl Protectant	221-515	11.95

Car Care | A27

& MAINTENANCE

Auto Dry Blade | 05



(05) Auto Dry Blade

This 11.5-inch Water Wand swipes away surface water. The soft silicone T-bar contours to your vehicle's shape and glides over any paint surface without scratching the finish. Produces 15% less friction than terrycloth. 001-575 \$16.95

Lockheed | 07



Castrol | 08



Classic Color Paints | 10



(10) Classic Color Spray Paints

Paints are ozone friendly. Bare metal must be primed to achieve satisfactory results. 12 oz. aerosol cans. Ground Shipping Only.

Olive Green Engine Paint	220-580	\$14.95
Black Engine Paint	220-575	8.95
Silver-Grey Disc & Wire Wheel Paint	220-560	14.95
Black Wrinkle-Finish Paint: Dashboards, Wiper Motors, etc.	220-570	10.95

(11) Finnigan's Waxoyl

Your best defense against rust. Starter kit includes 2.5 liter can of Waxoyl, pump and sprayer.

2.5 Liter Waxoyl Kit	225-360	\$76.95
2.5 Liter Waxoyl Refill	225-365	40.95
5 Liter Waxoyl Refill	225-370	57.95
400ml Waxoyl Spray	225-375	16.95

Stop Rust with Corrosion Block

Penetrates corrosion cells, removes moisture and leaves a protectant coating. Useful for protecting bare metal during a restoration project.

12 oz Aerosol (no air shipping)	225-380	\$16.95
32 oz Pump	225-385	35.95



Water Wetter

A wetting agent which helps coolant "bond" to metal surfaces thus increasing heat transfer. Highly recommended for all climates. 220-115 \$9.60



Dashpot Oil

Specifically designed for both SU and Zenith carbs this oil will ensure your car's proper performance 125 ml. 220-225 \$8.95



Transmission Gear Oil

Effective in all manual transmissions. Also improves copper corrosion protection to prolong the life of brass and bronze synchro rings, bushes, and thrust washers. (1 quart) 220-145 \$9.95

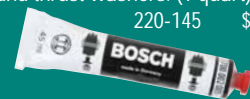

Bosch Distributor Grease

Specially formulated for use in distributors. It will not interfere with spark or catch fire. Will not solidify with age. This is the ideal lubricant for rebuilding your distributor, and lubricating the lobes on the distributor shaft, which will extend the life of the rubbing block on the points. 221-535 \$11.95



Connolly Hide Food | 06



(06) Connolly Hide Food

This is the famous "Hide Food," only the name has changed. Apply once a month to keep leather clean, soft and luxurious. Made in England. Connolly Hide Food 220-210 \$16.95

Connolly Leather Cleaner

Used for decades by the world's premier car manufactures. Easily removes difficult spots on your leather interior without drying the finish. 220-211 \$19.95



Lexol Leather & Vinyl Products

Leather Cleaner removes grime. Vinylex is designed for everything from dash tops to convertible tops.

Cleaner	220-190	\$14.95
Vinylex	220-185	15.95
Conditioner	220-195	14.95
Cond. Refill	220-200	12.50



Keyston Protectant

Formulated to beautify, moisturize and protect rubber and vinyl products. 220-180 \$11.95



Simichrome Metal Polish

Highly recommended polishing paste for brass, aluminum and chrome. Leaves a super shine with a protective film for lasting brightness. 225-350 \$10.15



Silicone | 09



Waxoyl | 11



Brake Fluids

Castrol LMA & Lockheed Brake Fluid:

Both LMA Brake Fluids exceed all factory DOT specifications. Compatible with all British brake systems.

(07) Lockheed 1 pint	220-400	\$5.10
(08) Castrol 1 pint	220-455	5.50
Castrol Gallon Can	220-505	44.95

Silicone Brake Fluid: Will not absorb moisture from the air like ordinary brake fluids, resulting in longer life for brake cylinders and hoses. One quart is sufficient for fluid change in one car.

(09) Silicone Brake Fluid	220-410	\$26.95
---------------------------	---------	---------



Shock Absorber Fluid

Custom blended specifically for British Girling and Armstrong lever action shock absorbers. Convenient flip-open pouring spout for easy refills. 16 fl. ounces. 220-304 \$9.95



A28 | Maintenance & FLUIDS

Assembly Lube | 01

Cam Lube | 02

Step 1 & 2 | 05



Hylomar | 03

Wellseal | 04

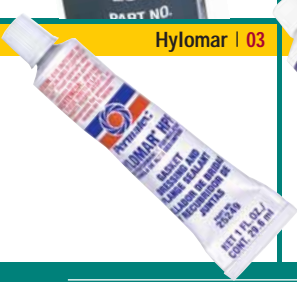

Engine Assembly Aids

"Ultra Slick" Engine Assembly Lube: Use "Ultra Slick" during assembly of camshafts, lifters, engine bearings, timing components, valves and guides and rocker shaft assemblies.

(01) Assembly Lube 221-565 \$6.25

Cam Lube: To make sure your new cam lasts a long time, use our cam lube when installing a new camshaft or lifters.

(02) Cam Lube 221-570 \$10.95

Hylomar HPF Gasket Dressing & Sealer: Holds gaskets in place during assembly and allows repositioning useable seal after assembly. Useable in temperatures from 60° to over 600°F.

(03) Hylomar 221-555 \$7.95

Wellseal Jointing Compound: Made in England and specified by many workshop manuals, this non-hardening gasket sealant allows you to float the gasket into position while staying flexible under load.

(04) Wellseal 221-540 \$18.95

ReLead & Stor-N-Start

Stor-n-start is an additive that prevents deposits from forming in fuel lines and carburetors. ReLead replaces the valve lubricating qualities of lead formerly used in gas.

Stor-N-Start 220-375 \$6.50
ReLead 220-390 10.95

Oil Spill Mat

Keep work area surfaces clean when changing the oils or taking on any job underneath your car.
Oil Spill Mat 221-605 \$18.95

(05) Fuel Tank Restoration

Step 1: Fuel Tank Restoration: We recommend using this bio-degradable cleaner in conjunction with the etching liquid when planning to seal a fuel tank. 1-gallon. 220-620 \$35.45

Step 2: Fuel Tank Restoration: Use this biodegradable etcher as a prep to our slushing compound to give maximum adhesion of the sealer. Our tank cleaner should be used first to remove oils or grime. 16 oz. 220-630 \$16.50

Step 3: Fuel Tank Restoration: This slushing compound fluid puts a protective film on the entire inside surface of your fuel tank to prevent rust and eventual fuel line blockage. Tanks should be cleaned with 220-620, then etched with 220-630 first. 220-450 \$35.95



Fender Cover

Our top-quality fender covers are imprinted with the logo of your MG marque. Foam rubber backing. MG Logo 241-725 \$24.95
AH Logo 241-735 24.95

Tool Creeper

This creeper helps keep your tools and parts close when working. Includes a magnetic center strip to keep things from moving. The foldaway handle makes it easy to store. Dimensions are 13" x 13" 384-895 \$23.95



(06) Self-Lifting Rolling Dolly Storage System

Slide the caster assembly under a wheel, press down on the pedal until the tire is gently lifted off the ground. The heavy duty casters allow easy movement to free up space in the garage.

Set of 2 Dollies 900-162 \$379.95

(07) Wheel Dolly Set

Make your life less complicated with this handy space saver. An essential to every garage, our easy to use dolly set enables your car to be moved sideways for convenient storage.

Set of 2 Dollies 900-161 \$199.95

(08) Auto Dolly

Wide heavy duty rollers and 6000 lb capacity makes maneuvering your car easy.

Set of Four Dollies 900-163 \$154.90

Parksmart Parking Mat | 09



(09) Parksmart Parking Mats

No more denting or scratching your bumper. The flat tongue uses the weight of your car to keep these mats in place. Sold individually.

Parking Mat 200-600 \$17.95

Disposable Gloves | 10



Disposable Mechanic's Gloves

Biodegradable natural latex gloves are ideal for any messy job. Provides a natural grip and feel that fits either left or right hand. 100 gloves per box.

(10) Disposable Gloves 228-690 \$10.95

Nitrile Hypoallergenic Gloves

Resistant to many common auto chemicals. Non-latex and hypoallergenic. 100/box 228-695 \$12.95



Workshop Tools | A29 & EQUIPMENT

Self-Lifting Dolly | 06



Wheel Dolly Set | 07



Auto Dolly | 08



Alignment Gauge | 11



(11) Alignment Gauge

When you work on your car's front end, the toe-in should be checked and adjusted. Take a measurement off the back of the front tires, measure again at the front and read the difference off the large scale, adjust your tie rod ends and measure again. 387-085 \$42.95

King Pin Reamer

To install new king pin bushings, they must be carefully reamed in perfect alignment after installation. Moss has the special factory king pin reamer. Not for cars with front drum brakes.

King Pin Reamer 386-380 \$302.95

(12) SU Tool Kit

An assortment of handy tools for the included. Suitable for all cars with SU carbs. Includes jet wrench (386-400) below. 386-300 \$23.95



SU Jet Wrench

Mixture adjustments on SU H and HS carburetors are much easier with the proper tool. 5/16" W (.600" nut) fits original carbs. 17mm (.669" nut) fits new upgraded carbs.

5/16" W Wrench 386-400 \$2.95
17mm Wrench 386-401 8.15

(13) Carburetor Synchronizer

Used to synchronize airflow between multiple carbs, this is an indispensable tool for the serious home mechanic. 386-200 \$32.95

(14) "Synchronometer" Flow Meter

Easy-to-read flowmeter allows accurate adjustment of multiple carburetor installations. Made in Germany. 375-321 \$48.95

Gunson's Colortune



A glass topped spark plug allowing you to see the color of combustion in your cylinders. Comes with special glass topped spark plug, viewing system for difficult plug locations, tuning procedure complete with troubleshooting guide. Gunson's Colortune 386-210 \$72.95

Flashtest

Gunson's Flashtest checks the condition of your car's ignition high-tension circuit, by measuring the voltage at the spark plugs. This tool can detect voltage problems at the start. 386-875 \$17.95

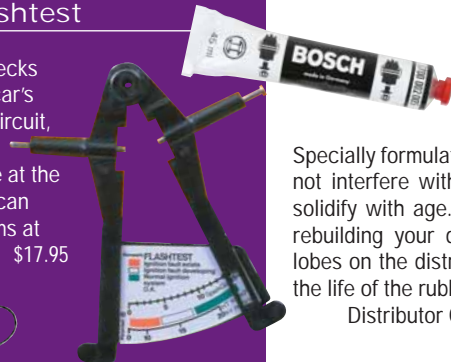

Bosch Distributor Grease

Specially formulated for use in distributors. It will not interfere with spark or catch fire. Will not solidify with age. This is the ideal lubricant for rebuilding your distributor, and lubricating the lobes on the distributor shaft, which will extend the life of the rubbing block on the points.

Distributor Grease 221-535 \$11.95

Shop Apron

MG logo shop apron with adjustable straps and three deep pockets.

217-200 \$19.75

Exhaust Gas Analyzer

Tune your car for best performance and low emissions. Measures carbon monoxide in your exhaust to help tune for best performance and economy. New digital version.

386-220 \$244.95



SU Tools | 12



Synchronizer | 13



Synchrometer | 14



Jet Centering Tool | 15



Ignition Wrench Set | 16



SU Jet Centering Tool

Jet centering is critical on older fixed needle SU carbs. This simple tool makes it a snap.

(15) Centering Tool 386-500 \$21.95

Ignition Wrench Set

High Quality Ignition Wrench Set by King Dick. Sizes 0 to 10 BA will handle most fasteners less than 1/4" on the car.

(16) Wrench Set 385-000 \$58.70



A30 | Workshop Tools

On-Board Battery Charger

- Attaches permanently to battery tray or fender well, mounting hardware included.
- Molded plastic sealed case resistant to water, gasoline, oil, solvents and acids.
- Charges & maintains 12-volt batteries.
- Totally automatic, if the battery drops 1 volt, the charger switches on, when fully charged it switches itself off.
- Every sports car owner who only uses his car part of the year needs one of these. Deep discharge appreciably shortens battery life.
- Operates from any regular 110-volt outlet. Unit remains in car. Dimensions: 5 1/2" x 3 1/2" x 1 1/2"



Battery Charger 386-245 \$59.95



High Tech Wheel Chocks

These wheel chocks have ridges on the ramp area and rubber pads under the leading edge to help stabilize tires to garage floor. Set of two. 900-150 \$15.25



RhinoRamps

Maximum-strength reinforced plastic. Full-depth internal ribs allow 12,000 pound gross vehicle weight. 17 degree incline angle (use on vehicles with low ground clearance), 6" working height, and 9 1/2" track width. Non-skid pads. Set of 2. Ramps 400-800 \$64.95



Lift-the-Dot Hand Punch

Aimed at Professional installers, this tool would make a fine car club tool box addition. Punches center hole and prong holes for installation of Lift-the-Dot fasteners to make installation of tops and tonneau covers a cinch. Lift-the-Dot Hand Punch 226-105 \$69.95



Tilt Lift | 01



Clickadjust | 02



Grease Gun | 03

(02) Clickadjust

Adjusting tappets is never a pleasant chore. This British tool takes much of the effort out of this necessary job. Turn the handle, click and tighten. Your clearance is set! Replaces the clumsy screwdriver/wrench combination with a single easy to use tool. Requires a 1/2" drive socket to fit tappet adjustment nut.

Clickadjust 386-205 \$80.95

(03) Grease Gun

For all those maintenance tasks.

386-710 \$38.95



Clutch Tool | 04

(04) Clutch Alignment Tool

For easy engine/transmission assembly.

948-1098-1275 387-320 \$4.95

Midget 1500 387-330 4.95

(01) Oberg Tilt Lift

Allows easy adjustment of an engine's lift angle through a full 90° of movement. Adjust with 1/2" ratchet; 2,000 pound capacity with a 3:1 safety load factor. A positive lock ensures the engine stays put. All steel construction & small size.

386-730 \$75.95



New!



Mityvac

This popular vacuum/pressure pump is perfect for bleeding hydraulic systems. Includes: vacuum/pressure pump, vacuum gauge, 1/4" tubing, automotive and brake bleeding adapter packages, reservoir jar and manual. Detailed instructions and ideas for additional uses. 386-215 \$39.95



Steering Wheel Nut Socket

An absolute necessity for removing steering wheel retaining nuts. A worthwhile investment — offered in 1 5/16" and 1 1/2".

Wheel Nut Socket 384-906 \$17.95

Mityvac Fluid Transfer Pump

Just what you need to add to your tool kit. Useful for transferring liquids or can be used as an inflator. Fill or drain gearbox or differential, includes hose reducer and pickup tube that will fit down many engine dipstick tubes.

386-275 \$15.95

Vizibleed Bleeder

Place the hose over a bleeder screw, put the check valve in an empty container, open the bleed screw and pump the pedal until clean, air bubble free fluid flows through the hose.

Vizibleed 386-885 \$17.95

Brake Lube Sachet

Aids in the assembly of natural rubber brake components. Recommended for master cylinder boots or hydraulic expander assemblies where rubber is present. Use one sachet per wheel.

Brake Lube 220-440 \$2.10

Snap Installation Tool

Install button snaps without damage.

386-980 \$9.85



Workshop Tools | A31

Air Powered Bleeder | 05



Eezibleed | 06



Engine Stand | 07



Portable Welder | 08



Castrol Oil Collectables | 09



(05) Professional Air Powered Bleeder

Air powered hydraulic bleeder uses siphon to bleed hydraulic systems. Hook the unit to air source, set air pressure to desired power, open the bleed screw and squeeze the handle.

Air Power Bleeder 386-225 \$159.95

(06) Eezibleed Kit

Kit includes a pressure vessel to hold new fluid, a pipe with interchangeable caps to fit most hydraulic master cylinders and an air hose to connect to a tire. Instructions included.

Eezibleed Kit 386-868 \$64.95

(07) Engine Roll Around Stand

If you have a spare engine to store, this stand makes it easy to move and keeps it off the ground. Dismantled, the engine stand stores easily until next needed.

Engine Stand 384-925 \$104.95

(08) 70 Amp Portable Arc Welder

Dual range AC welder can handle 1/16" - 3/32" mild steel making it perfect for chassis and body repairs on a limited budget. Includes 6' cables, sample electrodes and welding mask. Requires 120 Volts, 15 Amps.

386-241 \$138.50

(09) Castrol Oil Collectables

Classic Castrol Oil Cans look great in your den or garage.

2 Pint	216-565	\$26.95
1 Pint	216-555	21.95
1/2 Pint	216-545	19.95



Brake Pipe Tools

Small tool bends up to 1/4" diameter. Large tool bends up to 3/8" diameter to a minimum radius of 3/4". Clamp tool clamps flexible brake hoses.

Large Pipe Bender	385-895	\$89.95
Small Pipe Bender	385-885	34.65
Clamp Tool	386-855	16.50



Drum Brake Adjusting Wrench

Get a better grip on brake adjusters with our specially designed wrench. It has 1/4" and 5/16" square boxed ends, and a long handle for improved leverage.

386-160 \$12.95



Fire Extinguisher

2 lb. dry chemical extinguisher, U.L. rated 5-B:C to protect against electrical, fuel and oil fires. 11" x 3.5" size, mounting bracket included.

220-380 \$22.95



Chrome Halon Fire Extinguisher

Every classic car should have an affordable onboard insurance policy in the form of a functional fire extinguisher. Carrying one is just common sense. Halon is an extremely effective fire suppressant and causes the least amount of residual damage and is safe for human exposure. Our compact 10" chrome extinguisher can be easily mounted to many surfaces with the included bracket.

Extinguisher 220-381 \$129.95

A32 | MG & Healey Regalia

FUN STUFF

(01) Vintage Lucas Poster

Reproduction of a circa 1930 Lucas advertising poster. Lithographed in full color on heavy poster stock. 16" x 23 1/2". 214-205 \$14.95

(02) Bugeye Sprite Poster

This highly detailed cut-away rendering by S.E. Porter first appeared in the British magazine *The Motor* in 1958. 16" x 24". 213-165 \$10.95

Lucas Poster | 01



Bar Stool | 03



Official Dart Board | 04



THROUGH THE AGES...

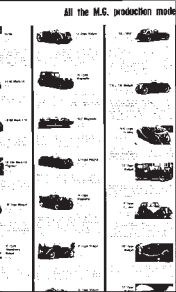

MG Through The Ages

Over 25 years ago, British Leyland issued this collector's poster from Abingdon announcing the 1981 auction of the MG factory. Depicts over 30 models from 1924-'65. 214-200 \$4.95

Poster | 02

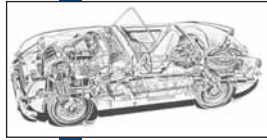

Official Tournament Darts & Dart Board

Made in England to World Dart Federation specifications. The board features logo prominently. 18" diameter. All dart sets come as a set of three 23 gram darts. Includes point sharper, additional shafts and a dart mechanic tool for adjusting tips and shafts.



AH Dart Board	229-665	\$43.95
MG Dart Board	229-780	43.95
Casino Royal Darts	229-675	30.95
Apollo Dart Set	229-690	32.75
Excaliber Dart Set	229-695	49.95



Factory Dealer Signs

Multicolored and superbly screen printed, these signs look exactly like the rare originals!

MG Service (12" x 16")	214-320	\$23.95
AH Service (6" x 24")	214-310	28.95
Austin-MG (12" x 48")	214-210	35.95

(03) Marque Logo Bar Stool

30" high, with padded 14" diameter seats covered with easy to clean vinyl. Chrome plated legs.

MG Logo Bar Stool	231-800	\$72.95
AH Logo Bar Stool	231-810	72.95

Beer Glasses

Colorful logo glasses to toast your favorite marque. Set of 4.

MG	230-931	\$19.95
Austin-Healey	230-933	19.95



MG Parking Sign

9" x 12" Aluminum. 215-760 \$23.95



Abingdon Auction Poster

Reproduction of the poster that announced the sad end of the famed MG factory. A little piece of history to hang in your den or garage.

214-120 \$9.95



Classic Driving Gloves

Your Choice	\$34.95	33.95
Small	Black Leather	String-Back
	228-700	228-800
Medium	228-710	228-810
Large	228-720	228-820
X-Large	228-750	228-830

MG Wine Glasses | 05



(05) Wine Glass Sets

Set of four MG Glasses	230-968	\$26.95
Set of four AH Glasses	230-988	26.95

Waterproof Picnic Blanket & Umbrella

A heavy fabric-backed vinyl outer shell with built-in carrying handles and snap closures so your blanket stays folded for easy storage. Inside, a wool picnic blanket which is removable for cleaning. Opens to 5' x 7'-1/2". For portable shelter, our wood handled MG "brolly" has room for two underneath.

Blanket	231-445	\$179.95
Umbrella	231-420	79.95



Union Jack Flag

Made of light-weight polyester with metal grommets on the hoist.

217-070 \$16.95

Apparel | A33 & ACCESSORIES

Flying Helmet & Goggles | 06



Classic Flying Helmet & Goggles

(06)

Reproduction of the helmets and flying goggles worn by WWII pilots of the Royal Air Force.

- RAF Goggles 219-945 \$109.95
- RAF Helmet, Medium 219-980 149.95
- RAF Helmet, Large 219-990 149.95
- RAF Helmet, X-large 219-995 149.95

(09) MG Letterman Jacket

Varsity style jacket with black wool body, quilted lining, brown leather sleeves and brown leather collar treatment, inside pocket, ribbed bottom. Zipper closure with snaps at waist, neck and cuffs. Collegiate style logo. Cut full size.

- Medium 013-440 \$184.95
- Large 013-441 184.95
- Xtra Large 013-442 184.95



Trunk Tote

Organizes your tools and other supplies. Made of heavy vinyl, with velcro covered wrench section and zipper pouch compartment for larger items. Size: 15" x 15". 647-105 \$17.95



Vehicle Cargo Organizers

Space Master cargo organizers allow you to keep small items from rolling around your trunk or back deck area. Easily organize and store cleaning or repair items.

- Folding 112-515 \$39.95
- Soft Sided 112-516 27.95

Hoodie | 07



A

B

(07) Hoodie Sweatshirts with Logo

100% Preshrunk Heavy Weight Cotton will keep your ears warm during cold snaps with the top down.

- | | | |
|-----------|---------|---------|
| A. Medium | 013-470 | \$49.50 |
| Large | 013-471 | 49.50 |
| X-Large | 013-472 | 49.50 |
| XX-Large | 013-473 | 49.50 |
| B. Medium | 013-480 | 49.50 |
| Large | 013-481 | 49.50 |
| X-Large | 013-482 | 49.50 |
| XX-Large | 013-483 | 49.50 |

Embroidered Pullover | 08



Letterman Jacket | 09



(08) Embroidered Pullovers

Night out with the top down, these poly fleece pullovers will keep you warm. \$56.95

- | | | | | |
|----|---------------|--------------|----------------|-----------------|
| | Medium | Large | X-Large | XX-Large |
| MG | 013-355 | 013-356 | 013-357 | 013-358 |
| AH | 013-350 | 013-351 | 013-352 | 013-353 |

Pendleton Motor Robes



Muffer | 10

Keep warm this winter with our big 52" x 70" Pendleton Mills 100% virgin wool blankets. Woven in a traditional Scottish plaid, they will keep you free from drafts and provide a touch of comfort at roadside picnics.

- | | | |
|-------------------|---------|---------|
| Red Lap Robe | 231-400 | \$71.95 |
| Green Lap Robe | 231-410 | 71.95 |
| (10) Green Muffer | 237-411 | 31.95 |

Embroidered Hat

Beige/Navy hats with your favorite marque embroidered in contrasting thread.

- | | | |
|----|---------|---------|
| MG | 219-822 | \$20.95 |
| AH | 219-832 | 20.95 |

MG Logo Earrings



Brightly enameled miniature marque logos. 219-730 \$12.95



Jigsaw Puzzle



Great for gifts, or for those long winter evenings when it is too cold for driving or fiddling with the car. 308 pieces.

- | | | |
|----------------------|---------|---------|
| Bugeye Jigsaw | 214-405 | \$19.95 |
| Sprite/Midget Jigsaw | 214-430 | 19.95 |



Embroidered Patches

Add a splash of color to jackets, sweaters, caps, or anything else you can think of.

- | | | |
|-----------------------|---------|--------|
| Large MG Patch | 229-505 | \$7.95 |
| Small MG Patch | 229-500 | 5.95 |
| MG Patch | 229-495 | 4.60 |
| British Leyland Patch | 229-560 | 5.95 |
| Union Jack Patch | 229-510 | 5.95 |
| BMC Rondell | 229-570 | 5.95 |

"Gambler" Straw Hat

Woven hats with embroidered logo band. Soft, cushion-stretch headband allows for a comfortable fit.

- | | | |
|----|---------|---------|
| MG | 218-708 | \$28.95 |
| AH | 218-738 | 28.95 |



A34 | Regalia

FUN STUFF

Cheese and Wine Set | 01



Bugeye Sprite | 02

MG Midget | 03



Embroidered T-Shirts

100% Cotton short sleeve allows comfortable fit and long-lasting durability. Embroidered with a British Car and diagonal portion of British flag on the front left and Moss block below collar on back. Your choice \$19.95

- (02) Bugeye Sprite

Medium 013-305	X-Large 013-307
Large 013-306	XX-Large 013-308
- (03) Sprite/Midget

Medium 013-310	X-Large 013-312
Large 013-311	XX-Large 013-313



British Marque T-Shirts

Let them know where your loyalties lie. Union Jack made up of British Motor Car Marques. 100% pre-shrunk cotton. Your choice \$18.95

- | | |
|----------------|------------------|
| Medium 013-430 | X-Large 013-432 |
| Large 013-431 | XX-Large 013-433 |

Ski Hats



These hats are serious cold weather gear- perfect for top-down driving when it's chilly. They are made from heavy-weight acrylic and have an anti-pill polar fleece lining that makes a huge difference. Stay comfortable, and keep the top where it belongs...down.

- | | | |
|---------------|---------|---------|
| MG Ski Hat | 013-410 | \$14.95 |
| Austin Healey | 013-411 | 14.95 |



Current Catalog Editions

- Austin-Healey 100, 100-6 & 3000
www.mossmotors.com
- Austin-Healey Sprite & MG Midget
www.mossmotors.com
- Jaguar XK120-140-150, XJ6-12, XJS, E-Type
www.mossmotors.com
- MG TC-TD-TF
www.mossmotors.com
- MGA
www.mossmotors.com
- MGB
www.mossmotors.com
- Triumph Spitfire MkIV -1500 & TR7
www.mossmotors.com
- Triumph TR2-TR3-TR4-TR4A
www.mossmotors.com
- Triumph TR250-TR6
www.mossmotors.com
- Mazda Miata
www.miatamania.com
- Chrysler PT Cruiser
www.cruiserbits.com
- BMW Mini
www.mossmini.com
- Ford F150
www.F150store.com
- Hummer H2
www.mossh2.com

Coming Soon...

- 05 Ford Mustang
www.fordmustangstore.com



How To Order | A35

SHIPPING RATES & PROCEDURES

PAYMENT

VISA, Mastercard, Discover, American Express, certified checks, money order or personal checks (which may be held until cleared). \$10.00 minimum order. If paying by charge card we will require charge card number, expiration date, complete billing address and the CVV2 code on back of card.



PRICES

All prices are subject to change without prior notice. Moss Motors reserves the right to correct any typographical errors.

SHIPPING

- Orders received by 3 p.m. local time are normally shipped the same day.
- We will ship by ground unless Air Delivery is specified.
- Alaska, Hawaii, Puerto Rico please use 2nd Day or Next Day Delivery only - add \$5 to chart. (Delivery times not guaranteed.)
- Oversize Shipments – Shipments under \$1,200 and over 130" length plus girth will be charged actual freight.
- Each shipment will reflect the appropriate shipping charges, including handling and insurance, listed on the chart below, dependent upon the parts value in each shipment.
- Orders shipped to California or New Jersey will be charged state sales tax.

FOREIGN ORDERS (Includes Canada)

Foreign orders are charged actual shipping charges. Shipping quotes provided on request. All duties and taxes are the responsibility of the customer. Foreign orders must be paid with a credit card or check in US funds. There is a \$10 charge to cover shipping and handling costs for catalogs shipped outside of the U.S. and Canada. One catalog per request.

PARCEL DELIVERY SERVICE

Follow these simple steps to figure your exact total...

1. Determine parts total and choose Ground or Air Service.
2. Figure your ground shipping and handling charges based on your parts total and area using the map and chart below.
3. CA and NJ residents add sales tax. You now have your combined order total.

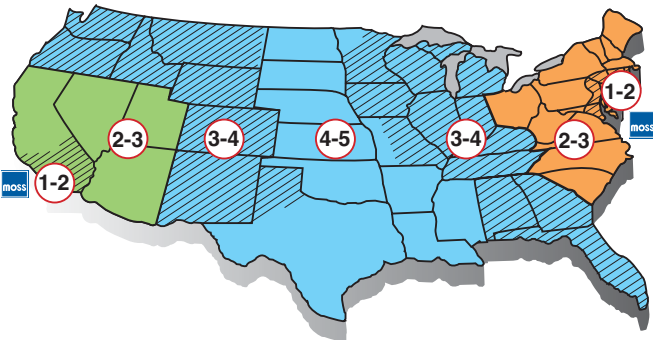

Areas / Approximate Delivery Time (In Days)

- This map represents approximate working days for Ground Delivery. (As quoted by our carriers, not guaranteed.)
- It also assumes that we can ship from the nearest warehouse. Items shipped from the alternate warehouse will take longer.
- Back orders can be cancelled at any time prior to shipment.

US - Ground Rates (48 States)			
Order Total	Western Area	Central Area	Eastern Area
\$10.00 to 20.00	\$6.15	\$6.95	\$6.85
20.01 to 50.00	8.75	10.25	9.95
50.01 to 75.00	10.95	12.95	12.65
75.01 to 100.00	12.95	15.30	14.95
100.01 to 150.00	14.95	17.60	16.95
150.01 to 200.00	16.95	19.95	19.35
200.01 to 300.00	19.45	22.95	22.15
300.01 to 400.00	21.95	25.95	25.20
400.01 to 600.00	24.95	29.35	28.50
600.01 to 1200.00	Free Ground Shipping in the contiguous 48 states. Oversize packages greater than 130" length plus girth and truck items will be charged actual freight.		
1200.01 and Up	Free ground shipping in the contiguous 48 states.		

SHIPPING continued

GUARANTEED AIR DELIVERY SERVICE (48 States)

- Guaranteed Next Day Air, Next Day Air Saver and 2nd Day Deliveries available.
- Next Day Air & Next Day Saver orders must be pre-paid by VISA, AMEX, MasterCard, or Discover.
- Moss guarantees that orders received before 3 p.m. your local time will arrive on time (barring weather problems, or "Acts of God"), or shipping and handling charges will be refunded.
- 2nd Day Air is guaranteed to be delivered by end of day the second business day after shipment. Next Day Air Saver is guaranteed to be delivered by end of day the day after shipment. Next Day Air is guaranteed to be delivered by 10:30 a.m., noon or end of day the day after shipment, depending on destination.
- Rates apply to orders with a real (or dimensional) weight of 50 pounds or less. If over this amount we will contact you with your shipping options.
- Saturday Delivery: Next Day Air orders placed on Friday for Saturday delivery will be charged an additional \$12.50. Saturday delivery does not apply to Next Day Air Saver and is not available in all areas.
- A.P.O., F.P.O. and P.O. Box orders are not guaranteed and will be shipped Parcel Post.

US - AIR RATES (AK, HI, PR add \$5.00)			
Order Total	2nd Day Air	Next Day Air Saver	Next Day Air
\$10.00 to 20.00	\$12.60	\$21.75	\$28.85
20.01 to 50.00	16.30	25.95	35.25
50.01 to 75.00	18.85	29.95	41.35
75.01 to 100.00	24.95	37.40	49.95
100.01 to 150.00	28.85	43.55	56.60
150.01 to 200.00	35.25	49.85	62.90
200.01 to 300.00	38.95	55.95	71.75
300.01 to 400.00	45.95	60.95	79.30
400.01 to 600.00	48.95	65.95	85.55
600.01 to 1200.00	37.75	54.85	72.95
1200.01 and UP	45.35	59.85	79.95

WHEN YOUR ORDER ARRIVES - Delivery of merchandise in good condition is the responsibility of the carrier. Should your order arrive in damaged condition, immediately inform a Moss Motors' customer service representative at 1-800-689-9313. You must make claims for damage during shipping to Moss Motors within 3 days. Keep original box and packing material. If your order was shipped truck freight, note damage on the bill of lading when signing the delivery receipt. If there is any other question about your order, contact customer service within 10 days.

BACKORDERS - Backordered items will be shipped and invoiced when available. Backorders are shipped free but carry a handling charge of \$1 per \$50 of value. You may request "No Backorders" or cancel backorders at any time prior to shipping. Canadian backorders will be charged based on actual freight. Canada is the only foreign country we backorder to.

WARRANTY - All products are warranted against defects in material and workmanship by the original equipment manufacturer or Moss Motors, Ltd., for 12 months from the date of shipment. We will replace the product or refund your purchase price at our discretion. The warranty does not cover labor, failure of a related component, failure resulting from faulty installation, nor would the liability of Moss Motors exceed the cost of the original component.

RETURNS - You may return new and uninstalled products in resalable condition for a full refund excluding shipping and handling charges for up to 6 months from date of invoice. Returns over 6 months, but less than 12 months will be charged a 10% restocking fee to cover our processing costs. We reserve the right to charge up to 20% when no invoice is supplied and/or there is substantial work involved to process your return back into stock. Items over 12 months old are not returnable. Please remember to always inspect the parts upon receipt of your order to avoid any difficulties later on. To return a part follow the instructions printed on the back of the invoice. Make sure to package the products carefully to avoid damage during return and include all original packaging and a copy of the invoice. Refunds will not be issued for installed, damaged, incomplete, "Custom" or "Special Order" items. If a return is due to our error, we will reimburse reasonable freight charges. We will not reimburse additional charges for shipping/packaging services. Electrical items that have been installed are not returnable.

CATALOG ERRORS - Every effort has been made to provide accurate information in this publication. We will not be held liable for inaccuracy of pricing, description or application.

800-667-7872 • Phone Orders
 Monday-Friday 6:00am to 7:00pm PST • Saturday-Sunday 7:00am to 4:00pm PST

805-692-2525 • Fax Orders

805-681-3411 • Technical Support

800-689-9313 • Customer Service
 Monday-Friday 7:00am to 5:00pm PST

805-681-3400 • Overseas

A	Door Skins42, 43	Lamps, rear61-62	Shop Tools & Equipment . . .A26-29
Accelerator Cable17	Driving GlovesA30	Lexol Leather ProductsA25	Side Curtains55,73
Air Filter, air pump19	Driving LampsA11	License Plate Frames/Covers A12	SignsA30
Air Filters, carb.20,21,22, A17		License Plate Mounts47,57	Sill CoversA10
Air Horn KitA7	E	License PlatesA11-12	Slave Cylinder, clutch27
Alternator68	E.G.R. Valve19	Lifter, valve, 150012	Sound DeadenerA7
AntennaeA12	Electric Fan KitsA20	Lifter, valve, 948-12757	Spark Plugs66
Apparel & GiftsA29-32	Electronic Ignition64, 65, A19	Limited Slip DifferentialA21	Speedometer Cable69
Axle Shafts, rear31	Emission Control19	Locking Gas CapA21	Spring, front, coil34, A21
	Engine Lock Tab Sets10	Lowering SpringsA21	Spring, rear, leaf36, A21
B	Engine Mounts, 150010	Luggage RacksA11	Sprockets, timing chain, 1500 .11
Badge Bar & BadgesA10	Engine Mounts, 948-12756		Sprockets, timing chain, 948-12758
Battery67, A20	Engine PerformanceA17-19	M	Stainless Steel ExhaustA16
Bearings, engine, 150011	Exhaust Systems18-19, A16	Manifolds, exhaust18	Starter Cables67
Bearings, engine, 948-12758		Mirrors, Door & fender53, A12	Starter68
Bearings, front axle34	F	Mirrors, windshield45	Steering Wheels32, A6
Bearings, rear axle31	Fan Belts14-15	Mufflers18-19	Steering33
Body Panels, Bugeye42, 44	Fans, radiator14-15		SU Carburetors20-21, A16
Body Panels, non-Bugeye .43, 44	Filter, air pump19	N	Sun Visors45
Bonnet StrapsA10	Filters, carb. air20-21	Needles, SU carb.20,21	Suspension, front34-35, A21
Books, Manuals, Videos . .A22-23	Fire ExtinguisherA28	Needles, Z-S carb.22	Suspension, rear36, A21
Brake Caliper PaintA15	Flasher Unit67	Number Plate Mounts47,57	Sway BarsA21
Brake Hoses39,40	Floor Mats74, A6		Switches70-71
Brake ToolsA 29	Floorboards44	O	Swivel Pin34
Brakes38-41, A15	Fog LampsA11	Oil Filter, 150010	T
Bulb, headlamp60	Front Suspension34-35	Oil Filters, 948-12756, A18	Tachometer Cable69
Bulb, instrument63	Fuel System20-25, A16	Oil Press. / Water Temp. Gauge 69	Tappets, 150012
Bulb, tail61,62	Fuse Box / Fuses67	Oil Pump, 150010	Tappets, 948-12757
Bumpers, front & rear56-57	G	Oil Pump, 948-12756, 6	Thermostat14-15
Bushes, front susp34-35, A21	Gasket Set, SU carburetor . .20,21	Overriders56-57	Tie Rod Ends33
Bushes, rear suspension .36, A21	Gasket Set, Z-S carburetor . .22		Timing Chain, 150011
	Gasket Sets, engine, 1500 .10,12	P	Timing Chain, 948-12758
C	Gasket Sets, engine, 948-1275 .6	P.C.V. Valve19	Tonneau Covers72
Cables, accelerator, choke .17	Gearbox, 150030	PaintA25	Tops and Top Fittings73
Cables, battery/starter67	Gearbox, 948-127528-29	Panel Kits74, A9	Transmission, 150030
Cables, speedo, tach69	Gearshift Knobs29,30, A7	PatchesA31	Transmission, 948-1275 .28-29
Camshafts, 150011	Generator68	Picnic BasketsA32	Trim Rings, wheel37, A14
Camshafts, 948-12759	GiftsA29-32	Piston Rings, 150011	T-ShirtsA32
Car CapsuleA12	Grille BadgesA10	Piston Rings, 948-12758	
Car Care & SuppliesA23-26	Grilles49	Piston, Brake Caliper40	U
Car CoversA13	Grommets52	Pistons, engine, 150011	U-Joint, driveshaft31
Carburetor Manuals23	H	Pistons, engine, 948-12758	Upholstery Kits74,75, A8-9
Carburetors, SU20-21, A16	Halfshafts31	PostersA30	
Carburetors, Weber23, A17	Handbrake40	Production DataA3	
Carburetors, Zenith-Stromberg 22	HardtopA12	Pulley, crankshaft, 150011	
Carpet74, A9	HatsA31-32	Pulley, crankshaft, 948-1275 .8	
Choke Cable17	Head Rests77	PulloversA31	
Clutch26-27	Headers19, A16	Pushrods, 150012	
Cockpit Fittings75	Headlamps60, A11	Pushrods, 948-12757	
Coil, ignition66	Heaters16-17	R	
Condenser, ignition64	Hinges, door58	Radiators14-15	
Connecting Rods, 150011	Hinges, hood47,48	Rear Axle31	
Connecting Rods, 948-12759	Hinges, trunk lid50	Rear Suspension36	
Connectors, electrical63	Hood StrapsA10	Rebuild Program80	
Conolly Leather Products .A25	Horns67	Release Bearing, clutch26	
Cooling System14-15	Hub Caps37	Ring Gear, 150011	
Crankshaft, 150011	I	Ring Gear, 948-12759	
Crankshaft, 948-12758	Ignition System64-66, A19	Rocker Arms, 150012	
Cup HolderA7		Rocker Arms, 948-12757	
Cylinder head, 150012	J	Rocker Panels42,43	
Cylinder Head, 948-1275 .7, A18	Jack Stowage Bag36	Rocker Shaft, 150012	
Cylinder Liners, 150010	Jack37	Rocker Shaft, 948-12757	
Cylinder Liners, 948-12758		Roll BarA21	
	K	Rotor, ignition64-65	
D	Key BlanksA6	Rugby ShirtsA31	
DartsA30	Key FobsA7		
Dash Pad Cover, 1968-18075	Knock Off Hammers37, A15	S	
Dashtop Repair PanelA10	Knock Offs37, A14	Seat Components76-77	
Diaphragm, Z-S carb.22		Seat Kits/Seat Covers 76-77, A5-8	
Diaphragm, SU fuel pump24	L	SeatbeltsA7	
Differential31	Lamp, license plate62	Sending Unit, fuel tank25	
Dipstick, engine6, 10	Lamps, dashboard63	Shift Knobs29,30, A7	
Distributors64, 65, A19	Lamps, front60-61	Shock Absorber, front34	
Door Fittings58		Shock Absorber, rear36, A21	
Door Pillars42, 43			
Door Seal75			

Restoration Parts

Sprite Midget



Sprite / Midget Restoration Parts Catalog

TABLE OF CONTENTS

MANUALS & BOOKS		2
PRODUCTION DATA	Identifying your car	3
TECH. SPECIFICATIONS	Car information	4-5
POWER UNIT	Engine, 948-1275	6-9
	Engine, 1500	10-12
	Engine accessories	13
COOLING & HEATING SYSTEM	Radiator, fan, pump & hoses	14-15
	Heaters	16-17
ENGINE CONTROLS	Control cables	17
EXHAUST / EMISSION CONTROL	Manifold, pipes, muffler	18-19
	Emission control	19
FUEL SYSTEM	Carburetors	20-23
	Pumps	24
	Tanks	25
DRIVELINE	Clutch	26-27
	Gearbox, 948-1275	28-29
	Gearbox, 1500	30
	Differential & Driveshaft	31
STEERING	Steering wheels	32
	Steering rack assemblies	33
SUSPENSION & WHEELS	Front suspension	34-35
	Rear suspension	36
	Road wheels	37
BRAKES	Master cylinders	38
	Drum brakes	39
	Disc brakes	40
	Handbrake	40
	Pipes, fluid, tools	41
BODY PANELS & FITTINGS	Body panels, outer	42-43
	Body panels, inner	44
	Windshields	45
	Body fittings, Bugeye	46-47
	Body fittings, 1961-'80	48-50
	Body mouldings, Miget	51
	Plugs, grommets, badges, mirrors	52-53
	Door windows / Sidecurtains	54-55
	Bumpers	56-57
	Door fittings	58
ELECTRICAL	Wipers / Washers	59
	Headlamps	60
	other Lamps	61-62
	Wiring harnesses & wiring fittings	63
	Distributors	64-65
	Ignition	66
	Battery, Misc. electrical	67
	Starter / Generator / Alternator	68
DASHBOARD	Gauges & Cables	69
	Dashboard	70-71
SOFT TRIM	Tonneau covers	72
	Tops	73
	Panel kits & Carpets	74
	Cockpit fittings	75
	Seats	76-77

About This Catalog

This catalog covers parts for USA-specification left hand drive cars. In producing this catalog, our primary goal was to publish a listing of Sprite & Midget parts which was as comprehensive, accurate and informative as possible for the USA market. In doing this, we have made every effort to correctly identify and include every part likely to be needed to repair, restore or maintain your car. Although some of the parts listed are not currently available, our Product Development staff is constantly seeking new suppliers and manufacturers of quality reproductions of otherwise obsolete items. The current Moss Motors website (www.mossmotors.com) pricing is always the best indication of availability.

Local laws and regulations relating to pollution, safety and lighting equipment vary considerably from state to state and country to country. Since we distribute parts for these cars on a worldwide basis, we are not in a position to advise what laws are in effect in each locality. We strongly encourage anyone contemplating any modifications to a vehicle intended for street use, to check local regulations before proceeding. We strongly suggest that you save all old stock equipment should reinstallation be necessary at a future date.

NOTE: In the body of this catalog, items with indented descriptions are components of the non-indented kit or assembly above them.

Supersession and Rationalization of Parts

Most owners of British cars have, at one time or another, ordered an original "factory" part from an authorized dealer, only to find that the part received was different from the original, although it did work. This is the result of the supersession or rationalization of parts by the factory. Supersessions occur when a part is modified, and the original design or pattern is no longer produced. If old and new parts are interchangeable, even though they may appear slightly different, the old part is superseded by the new part. Rationalization is an attempt by the factory at efficiency in which one new part replaces several original parts, after which the original parts are no longer available.



This truck symbol indicates that the item is shipped by truck, freight collect, payable on delivery.

WARNING!

Working on automobiles is inherently dangerous. Moss Motors, Ltd. is not liable for injury or damage due to incorrect installation or use of their products. All products are sold with the understanding that the safe and proper installation and use of the products is the customer's responsibility. Follow factory workshop manual procedures and instructions, but use current shop safety standards and common sense. Some tasks will require professional advice or services which Moss Motors cannot provide.



BRITISH MOTOR
HERITAGE APPROVED

By special licensing agreement with British Motor Heritage Ltd., Moss Motors, Ltd., is a fully authorized manufacturer and distributor of British sports car spares. With official support from the original manufacturer, we are able to produce a wide range of reproduction spares which meet or exceed the original factory standard of quality. In conjunction with British Motor Heritage, Ltd., Moss Motors is dedicated to the preservation and restoration of British sports cars. The British Motor Heritage, Ltd. and marque trademarks, as well as some exploded view artwork included in this publication, are the property of British Motor heritage, Ltd., and are reproduced under licensing agreement by Moss Motors, Ltd.



Sprite-Midget Parts Catalog

© Copyright Moss Motors, Ltd. April, 1979
Edition SPM-0508 August, 2005
Printed in the USA

All rights reserved. No part of this publication may be reproduced, stored in a retrieval system, or transmitted in any form or by any means, electronic, photocopying, recording, or otherwise without the prior written permission of Moss Motors, Ltd.

LOCAL & OVERSEAS: 805-681-3400
FAX: 805-692-2525 www.mossmotors.com

MOSS

Manuals & Books

Factory Workshop Manual Reprints



Bugeye Sprite	212-465	\$63.95
Sprite MkII on Midget to '74	212-475	\$68.95
Midget 1500	212-415	\$52.95



Haynes Workshop Manual

Excellent guide to Sprite/Midget tune up and maintenance.
212-380 \$18.95

Owners' Manual Reprints

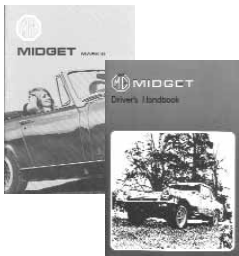

Sprite Mki (Bugeye)	212-690	\$18.95
MG Midget MkIII ('68-'74)	212-705	\$18.95
MG Midget 1975-'78	213-310	\$19.95
MG Midget 1979-'80	213-320	\$19.95

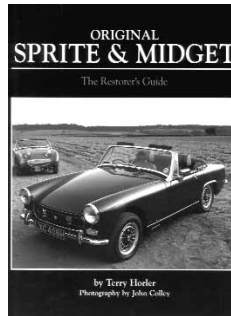

Original Sprite & Midget by Terry Horler

Highlighting every detail, production change, and mechanical specification, this is the definitive guide to bringing these "honest little sports cars" back to their original condition - from the "Frogeye" Sprite MkI to the rubber bumpered Midget 1500. Softbound, 8 3/4" x 11 1/2", 144 pages, over 225 color photographs.
211-406 \$24.95

Restoring Sprites & Midgets by Grahame Bristow

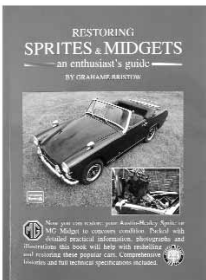

Now you can restore Your Sprite or Midget with the help of this comprehensive and entertaining book. Packed with detailed practical information, photographs, illustrations, and technical specifications. Softbound, 8" x 10-3/4", 210 pages.

213-305 \$44.95



Glovebox Size Workshop Manual

Though not as complete as the full factory manuals, this clever new manual is packed with information. Tune up data, repair and rebuilding information, dimensions and torque specs are all here in this compact 5-1/2" x 8-1/2" x 11", 520 pages.
212-480 \$29.95

Brooklands Gold Portfolio



Actual articles from road tests of the era. In-cludes impressions, technical data and comparison tests done when the cars were new. Softbound, 8" x 10", approx. 160 pages.
212-359 \$46.95

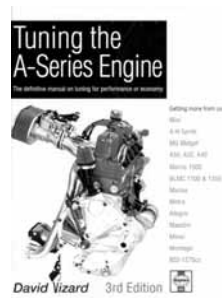

Tuning A Series Engines by David Vizard.

New 3rd Edition. Highly detailed and complete coverage of building and tuning tips. Originally written for the Mini owner, this is a "must-have" for every A-Series Spridget owner. Much of the information is also applicable to the bigger B series engine as used in the MGB. Hardbound, 8-1/2" x 11", 520 pages.
212-160 \$44.95

Identification Numbers

When ordering parts it is essential to identify your car exactly. Since the changes made by the factory in the course of production have been followed over the years by individual changes made by each owner, it can be extremely difficult in some cases to correctly identify some of the components of your car. To compound the problem, some states title a car by its year of sale rather than the year of its manufacture. In order to make it as easy as possible for you to give us the information we need to supply you with the proper parts, we have found that the common practice of referring to the car series by its engine size ("948, 1098, 1275, & 1500") works quite well and have adopted this system for our listings where possible. Where further detail seemed necessary, we have used the "Mark Series" and "model year" (which should not be confused with the build date). In a few cases, especially in the later cars, we have cited engine and body numbers.

For the sake of simplicity we delete the alpha numeric prefix from the change points in our application. Example G-AN4-72033 is (c)72033. These letters will pinpoint certain production features but will not affect the application of individual parts as listed. Considering the few remaining "original" Spridgets, this seems to be a rational system that covers most applications.

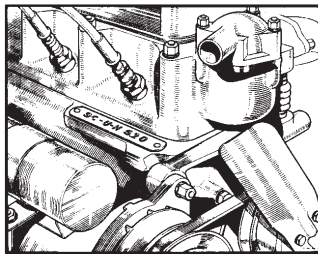

Location of 948, 1098, 1275 engine number stamped in the block

Engine Identification

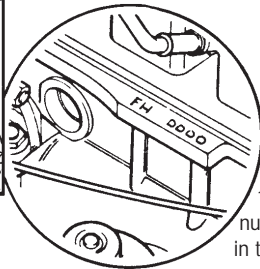

Location of 1500 engine number-stamped in the block

Example: 9 CG/ U/ H 12345

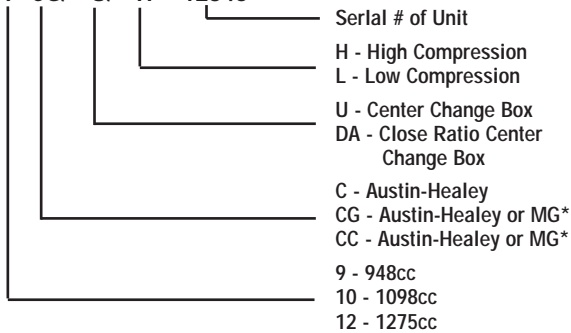

* also used are: CE, CF, CH, CJ, CK, & V

Note: The serial numbers on Spridget engines do not match the chassis or body numbers.

There are several good published sources of Sprite/Midget production data. Some variation occurs due to inconsistencies in factory record keeping and individual interpretation of available data. Production dates are sometimes confused with model year dates. The factory kept no running totals. The entire Sprite/Midget production came from Abingdon except for 489 Sprites and 476 Midgets which were built at Cowley in 1967. These "Cowley" Spridgets may carry an "M" suffix.

Chassis Numbers

The chassis number is stamped on a plate secured to the left-hand inner wheel arch valance under the hood and provides basic information about your car.

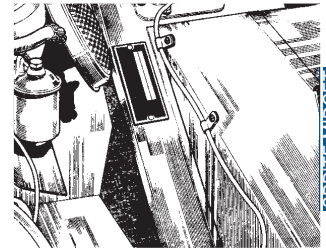

SPRITE-MIDGET

Example: H AN5 L 12345

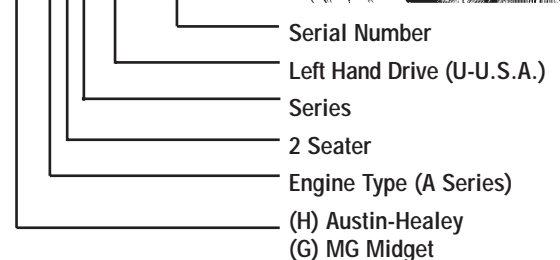

Note: An additional prefix was used from 1970 to indicate the model year.

Production Information

Model Year	Build Date	1st Car of model year	Model
	Jun 1961	G-AN1-101	MkI (948)
	Sep 1962	G-AN2-16184	MkI (1098)
	Mar 1964	G-AN3-25788	MkII
1967	Oct 1966	G-AN4-52390	MkIII (1275)
1968	Nov 1967	G-AN4-60460	MkIII
1969	Dec 1968	G-AN4U-66226	MkIII
1970	Sep 1969	G-AN5UA-74886	MkIII
1971	Jun 1970	G-AN5UB-89515	MkIII
1972	May 10, 1971	G-AN5UC-105501	MkIII
1973	Jul 13, 1972	G-AN5UD-123731	MkIII
1974	Aug 23, 1973	G-AN5UE-138801	MkIII
1975	Nov 19, 1974	G-AN6UF-154101	1500
1976	Aug 1975	G-AN6UG-166301G	1500
1977	Dec 14, 1976	G-AN6UH-188001G	1500
1978	Aug 24, 1977	G-AN6UJ-200001G	1500
1979	May 9, 1978	G-AN6UL-212001G	1500
	Dec 7, 1979	G-AN6-22526	last Midget

(There seem to have been no "official" 1980 model year Midgets, although some USA cars are titled as such.)

Sprite

	Mar 31, 1958	H-AN5-501	MkI ("Bugeye")
	Feb 1961	H-AN6-101	MkII (948)
	Sep 1962	H-AN7-24732	MkII (1098)
	Mar 1964	H-AN8-38829	MkIII (1098)
1967	Oct 1966	H-AN9-64735	MkIV (1275)
1968	Nov 1967	H-AN9-72041	MkIV
1969	Dec 1968	H-AN9-77591	MkIV

(Sprite exports were stopped for all foreign markets in early 1969, although production for the home market continued until July 6, 1971.)

	BUGEYE SPRITE	948 SPRITE MKII,MIDGET MKI	1098 SPRITE MKII,MIDGET MKI SPRITE MKIII,MIDGET MKII
Vehicle Identification	HAN5	HAN6,GAN1	HAN7,GAN2 / HAN8,GAN3
Vehicle Number Location	LH FT FRAME	LH FT FRAME	LH FT FRAME
Engine Number Location	RH FT.	RH FT.	RH FT
Gearbox Number Location	TOP CASE	TOP CASE	LH CASE
Rear Axle Number Location	LH TUBE	LH TUBE	LH TUBE
Tune Up			
Engine Firing Order	1342	1342	1342
Valve Rocker Clearance	.012 COLD	.012 COLD	.012 COLD
Static Ignition Timing	5 BTDC	4 BTDC	5BTDC
Dynamic Ignition Timing			8BTDC @ 600RPM
Timing Mark Location	BOTTOM TIMING COVER	BOTTOM TIMING COVER	BOTTOM TIMING COVER
Distributor Make/Type	LUCAS DM2.	LUCAS DM2P4	LUCAS 25D
Contact Breaker (points) Gap	.014 TO .016	.014 TO .016	.014 TO.016
Rotation of Rotor	COUNTER CLOCKWISE	COUNTERCLOCKWISE.	COUNTERCLOCKWISE
Dwell Angle			60
Ignition Coil Make/Type	LUCAS LA 12.	LUCAS LA12	LUCAS LA12
Spark Plug Make/Type	CHAMPION N5.	CHAMPION N5.	CHAMPION N5
Spark Plug Gap	.024 TO .026	.024 TO .026	.024 TO .026
Carburetor Make/Type	SU H2	SU HS2	SU HS2
Carburetor Main Jet	.090	.090	.090
Carburetor Main Jet Needle	GG	V3	GY (HAN7,GAN2), AN (HAN8,GAN3)
Carburetor Piston Spring	NONE	LIGHT BLUE.	BLUE
Vehicle & Engine			
Length	11 FT 5-1/4 IN	11 FT 5-5/8 IN	11 FT, 5-5/8 IN
Width	4FT 5IN	4FT, 5IN"	4FT,6-7/8IN[4FT,8-1/2IN W/WH]
Height	4FT 1-3/4 IN	4 FT,1-3/4 IN	4FT,1-3/4 IN
Ground Clearance	5IN.	5IN.	5 IN
Track Front	3FT 9-3/4 IN	3FT,9-3/4 IN.	3FT,10-5/16 IN
Track Rear	3 FT 8-3/4 IN	3FT, 8-3/4 IN	3FT, 8-3/4IN [3FT,9-1/4IN W/WH]
Wheelbase	6FT 8IN	6FT,8IN	6FT,8IN
Turning Circle	31FT 6 IN.	32FT,1-1/2IN LH, 31FT,2-1/2IN RH	32FT,1-1/2IN LH, 31FT,2-1/2IN RH
Toe-In	0 TO 1/8 IN	0 TO 1/8 IN	0 TO 1/8 IN
Curb Weight	660 KG	1400 LBS.	1466 LBS (HAN7,GAN2), 1490 LBS (HAN8,GAN3)
Original Tire Size	5.20 X13	5.20 X13	5.20 X 13
Original Tire Pressure Front (Cold)	18	18	18
Original Tire Pressure Rear (Cold)	20	20	20
Replacement Tire Size	145 SR 13	145 SR 13	145 SR 13
Engine Type	OHV	OHV	OHV
Engine Displacement	948cc.	948 cc	1098 cc
Firing Order	1342	1342	1342
Compression Ratio	8.3:1	9:1	8.9:1
Engine Bore	2.478	2.478	2.543
Engine Stroke	3.00	3.00	3.296
Number of Cylinders	4	4	4
Oil Pressure Idle	10 TO 25	10 TO 25	10 TO 25
Oil Pressure Normal	30 TO 60	30 TO 60	30 TO 60
Ignition Type	POINT	POINT	POINT
Fuel System Type	CARB.	CARB.	CARB
Fuel Pump Make/Type	AC/SPHINX Y TYPE	AC/SPHINX Y TYPE	AC/SPHINX Y TYPE mechanical (HAN7,GAN2), SU AUF 200 electric (HAN8,GAN3)
Fuel Tank Capacity	7.2	7.2	7.2
Cooling System Capacity	12 PINTS	12 PINTS	12 PINTS
Sump Capacity	7.8 PINTS	7.8 PINTS	7.8 PINTS
Gearbox Capacity, non-overdrive	2.7 PINTS	2.7 PINTS	2.7 PINTS
Gearbox Capacity, overdrive			
Rear Axle Capacity	1-3/4 PINTS.	1.8 PINTS	1.8 PINTS

	SPRITE MKIV,MIDGET MKIII	SPRITE MKIV,MIDGET MKIII	1500 MIDGET
Vehicle Identification	HAN9,GAN4	HAN10,GAN5	GAN6
Vehicle Number Location	LH FT FRAME	LH B PILLAR,LH W/S	LH B PILLAR,LH W/S
Engine Number Location	RH FT.	RH FT.	LH REAR
Gearbox Number Location	LH CASE	LH CASE	RH TOP CASE
Rear Axle Number Location	LH TUBE	LH TUBE	LH TUBE
Tune Up			
Engine Firing Order	1342	1342	1342
Valve Rocker Clearance	.012 COLD	.012 COLD	.010
Idle Speed	700 [1000 68 ON]	1000	700 TO 900
Static Ignition Timing	7 BTDC	7 BTDC	10 BTDC [2 ATDC CALIF.]
Dynamic Ignition Timing	10 BTDC @ 1000RPM	13 BTDC @ 1000	2 ATDC [10 BTDC '78 ON FED.]
Timing Mark Location	BOTTOM TIMING COVER	BOTTOM TIMING COVER	LH TOP
Distributor Make/Type	LUCAS 25D	LUCAS 25D	LUCAS 45DE4
Contact Breaker (points) Gap	.014 TO .016	.014 TO .016	
Rotation of Rotor	COUNTER CLOCKWISE	COUNTER CLOCKWISE	COUNTERCLOCKWISE
Dwell Angle	60	60	
Ignition Coil Make/Type	LUCAS 11C 12 [HA12 '68 ON]	LUCAS HA 12	LUCAS 15C6
Primary Resistance	3 TO 3.4 OHMS	3 TO 3.4 OHMS	1.30 TO 1.45 OHMS
Spark Plug Make/Type	CHAMPION N9Y	CHAMPION N9Y	CHAMPION N12Y
Spark Plug Gap	.024 TO .026	.024 TO .024	.025
Carburetor Make/Type	SU HS 2	SU HS 2	ZENITH-STROMBERG 150CD4
Carburetor Main Jet	.090	.090	.100
Carburetor Main Jet Needle	AN [AAC '68,'69]	AAC [ABC '72 ON]	44A,45Q,45K,45R,BY CARB#
Carburetor Piston Spring	LIGHT BLUE	LIGHT BLUE	BLUE
Vehicle & Engine			
Length	11 FT, 5-5/8 IN.	11FT,4-1/2IN	11 FT,9 IN
Width	4FT ,6-7/8" [4FT,8-1/2"W/W]	4 FT,5-5/8IN [4FT,8-1/2 W/W]	4FT,6-7/8 IN [4FT,8-1/2 IN W/W]
Height	4 FT,5/8 IN.	4 FT,1/4IN	4FT -1/4 IN
Ground Clearance	5IN.	5 IN	3-1/4 IN
Track Front	3 FT,10-5/16 IN	3FT,10-9/16""[3FT,10-5/16""W/W]	3 FT,10-9/16IN [3FT,10-5/16IN W/W]
Track Rear	3 FT,8-3/4IN [3FT,9-1/4IN W/W]	3FT,9IN [3FT,1/4""W/W]	3FT,9IN [3FT,9-1/4IN W/W]
Wheelbase	6 FT,8IN	6FT,8IN	6FT,8IN
Turning Circle	32FT,1-1/2IN LH,31FT,2-1/2IN RH	32FT,1-1/2 LH,31FT,2-1/2IN RH.	32FT,1-1/2IN LH,31FT,2-1/2IN RH
Toe-In	0 TO 1/8 IN	0 TO 1/8 IN	0 TO 1/8 IN
Unladen Weight	1,510 LBS [1,519 '68,'69]		
Curb Weight		1.701 LBS	1,849 LBS
Gross Weight			2,229 LBS
Original Tire Size	5.20X13 [145SR 13 RADIAL]	145SR 13.	145 SR-13
Original Tire Pressure Front (Cold)	18 [22 RADIAL]	22	22
Original Tire Pressure Rear (Cold)	20 [24 RADIAL]	24	24
Replacement Tire Size	145SR 13		
Engine Type	OHV	OHV	OHV
Engine Displacement	1275 cc	1275 cc	1493 cc
Firing Order	1342	1342	1342
Compression Ratio	8.8:1	8.8:1 [8.0:1 '72 ON].	9:1 FED TO '77, 7.5:1 CA,FED'78'79
Engine Bore	2.78 IN.	2.78IN	2.9
Engine Stroke	3.2 IN.	3.2 IN.	3.44
Number of Cylinders	4	4	4
Oil Pressure Idle	20	20	20
Oil Pressure Normal	40 TO 70.	40 TO 70	40 TO 60
Ignition Type	POINT	POINT	ELECTRONIC
Fuel System Type	CARB	CARB	CARB
Fuel Pump Make/Type	SU AUF 206	SU AUF216	AC DELCO RA1
Fuel Tank Capacity	7.2	7.2 [8.6 '72 ON]	7.5
Cooling System Capacity	12 PINTS [7 PINTS '68 ON]	7 PINTS	11.4 PINTS
Sump Capacity	7.8 PINTS	7.8PINTS	9.6 PINTS
Gearbox Capacity	2.7 PINTS	2.7 PINTS	1.75 PINTS
Rear Axle Capacity	2.1 PINTS	2.1 PINTS	2.1 PINTS

External Engine 948 - 1098 - 1275

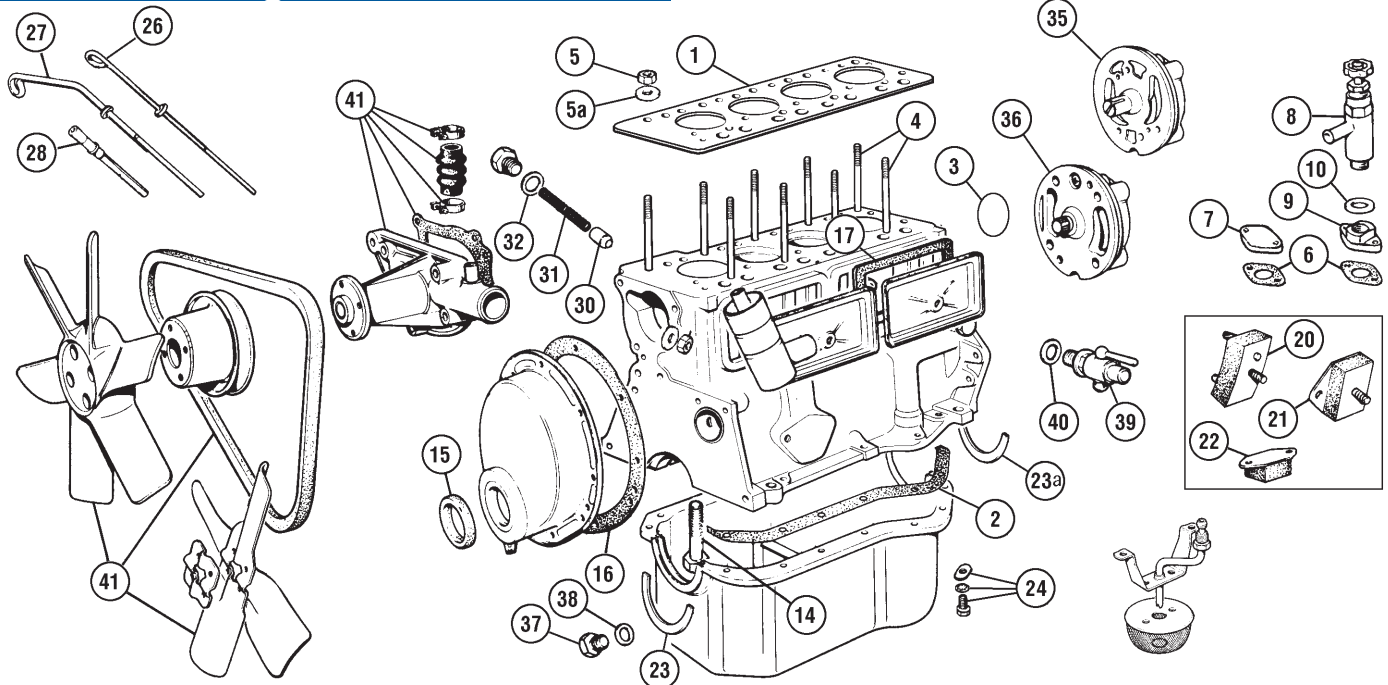

No.	Part No.	Price (each)	Description	Application	Qty. Req.
	220-580	\$14.95	PAINT, correct olive green (spray can)	all except 12V	1
	220-575	\$8.95	PAINT, black	1275 12V	1
			HEAD GASKET SETS See facing page.		1
1	694-535	\$9.95	HEAD GASKET	948 - 1098	1
	694-525	\$9.95	HEAD GASKET	1275	1
	694-555	\$25.95	COMPETITION HEAD GASKET	1275	1
	296-661	\$34.95	GASKET SET, lower engine, Payen	948, 1098 (10 CG)	1
	296-662	\$28.95	GASKET SET, lower engine **		1
	296-671	\$35.95	GASKET SET, lower engine, Payen	1098 (10 CC)	1
	296-672	\$20.95	GASKET SET, lower engine **		1
	296-681	\$41.95	GASKET SET, lower engine, Payen	1275cc	1
	296-682	\$21.95	GASKET SET, lower engine **		1
			** Products of various manufacturers supplied.		
2	296-655	\$7.80	SUMP GASKET (2 pcs.)	948-1098	1
	296-665	\$8.95	SUMP GASKET (2 pcs.)	1275	1
3	328-230	\$1.05	CORE PLUG	thru (e)10CC/DA/H3495	4
	328-235	\$1.00	CORE PLUG	10CC/DA/H3496 to end of 10CC	4
	328-265	\$0.75	CORE PLUG	1275cc	5
4	329-715*	\$3.20	CYLINDER HEAD STUD, long		4
	329-725*	\$5.60	CYLINDER HEAD STUD, short		5
5	310-280	\$0.85	NUT, cylinder head		9
5a	324-725	\$0.80	WASHER, head stud		9
6	296-455	\$0.75	GASKET, heater valve		1
7	360-215	\$6.70	BLANKING PLATE, heater valve	(when heater not fitted)	1
8	360-400	\$29.95	HEATER VALVE	948, 1098, 1275cc	1
9	360-415	\$4.95	BASE, heater valve		1
10	324-065	\$0.95	GASKET		A/R
14	322-890*	NA	BOLT, main brg. cap	948 - 1098	6
	322-895*	NA	BOLT, main brg. cap	1275	6
15	121-500	\$1.95	OIL SEAL, felt	948 to (e)9C-H37646	1
	120-000	\$4.70	OIL SEAL, rubber	from 948 (e)9C-H37647 on	1
16	296-510	\$2.95	GASKET, timing cover	all	1
17	296-370	\$0.95	GASKET, side cover, cork	948 - 1098	2
	296-375	\$2.95	GASKET, side cover, rubber	1098	2
20	413-160	\$6.95	ENGINE MOUNT, R/H & L/H		2
21	413-170	\$10.95	TRANSMISSION MOUNT, R/H & L/H		2
22	413-180	\$6.95	TRANSMISSION MOUNT, center		1
23	297-640	\$5.25	SUMP SEAL, front	included in lower engine gasket sets	1
23a	297-645	\$5.40	SUMP SEAL, rear		1
24	322-675	\$8.05	FITTING KIT, sump (oval washers, lockwashers, & bolts)		1
26	451-410	NA	DIPSTICK, straight	1098 - 1275	1
27	451-420	NA	DIPSTICK, bent (use earlier 451-410)	1275	1
	031-220	\$1.40	SEAL for bent dipstick	late 1275	1
28	451-430	\$9.95	DIPSTICK TUBE	1098 - 1275	1
30	460-155	\$8.70	VALVE, oil pressure release		1
31	329-185	\$1.95	SPRING, oil pressure release		1
32	324-800	\$0.65	WASHER, cap nut		2
35	435-630	\$47.95	OIL PUMP, pin drive	948 - 1098	1
36	435-640	\$39.95	OIL PUMP, star drive	1275	1
37	328-280	\$5.85	PLUG, oil drain, stock type		1
	328-282	\$4.95	PLUG, oil drain, magnetic	(option)	1
38	324-626	\$0.40	WASHER, drain plug		1

*See page 9 for high tensile studs, nuts, and bolts.

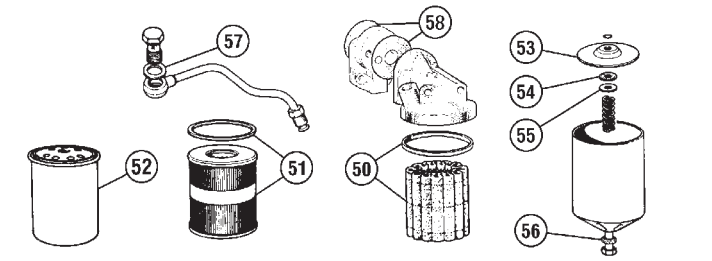

No.	Part No.	Price (each)	Description	Application	Qty. Req.
39	470-240	\$19.95	TAP, water drain		1
40	324-670	\$0.60	WASHER, fiber		1
41			COOLING SYSTEM, see page 14-15.		
Oil Filters					
50	950-040	\$15.40	OIL FILTER, felt, "Crosland" brand	948, 1098, 1275	1
	950-540	NA	OIL FILTER, felt, various manufacturers		1
51	950-020	\$10.10	OIL FILTER, paper, "Crosland" brand	1275	1
	950-520	\$8.45	OIL FILTER, paper, var. manufacturers		1
52	950-045	\$8.45	OIL FILTER, spin-on, "Crosland" brand	1275	1
	950-545	\$6.85	OIL FILTER, spin-on, var. manufacturers		1
53	435-150	\$7.35	PLATE		1
54	435-560	\$0.75	WASHER, felt		1
55	435-570	\$0.50	WASHER, steel		1
56	460-805	\$0.95	SEAL, 'Tecalomit'		1
	460-815	NA	SEAL, 'Purolator'		1
57	324-805	\$1.55	SEAL, copper		2
58	296-565	\$1.65	GASKET		2

Spin-On Oil Filter Adaptor

This Moss-designed filter head & pipe enables the use of a high capacity and economical spin-on filter. Does not fit Midget 1500.

235-875	\$98.95	Spin-on Adaptor
235-880	\$5.95	Filter, Fram
235-830	\$13.95	Filter, K&N
235-855	\$11.95	Filter, Wix

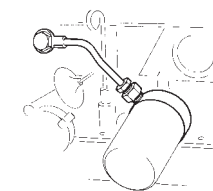

Competition Gaskets

Highly recommended for use with high compression pistons and modified heads, the copper and asbestos head gasket is made to original British Leyland specifications. The special manifold gasket has enlarged holes to match inlet and exhaust ports on modified cylinder heads.



Competition Head Gasket (1275)	694-555	\$25.95
Competition Manifold Gasket (948 - 1275)	296-645	\$8.95

Cylinder Head 948 - 1098 - 1275

SPRITE-MIDGET

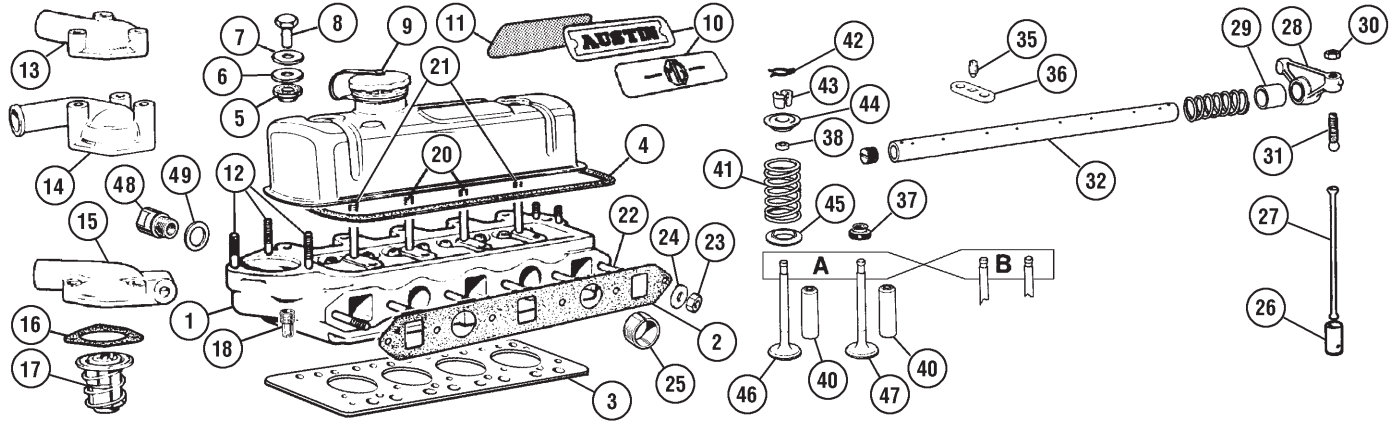

No.	Part No.	Price (each)	Description	Application	Qty. Req.	
1	451-875	\$1,049.95	ALLOY CYLINDER HEAD, new (use 1275 valves, springs, retainers)		1	
	296-641	\$29.95	HEAD GASKET SET, Payen	} 948 & 1098cc	1	
	296-642	\$21.95	HEAD GASKET SET **		1	
	296-651	\$40.95	HEAD GASKET SET, Payen		} 1275cc	1
	296-652	\$26.95	HEAD GASKET SET **			1
	296-653	\$38.95	HEAD GASKET SET, Payen (w/copper head gasket)	1275	1	
** Products from various manufacturers supplied.						
2	296-630	\$1.95	MANIFOLD GASKET		1	
3	694-535	\$9.95	HEAD GASKET	948 - 1098	1	
	694-525	\$9.95	HEAD GASKET	1275	1	
4	296-005	\$4.55	GASKET, valve cover		1	
5	460-120	\$0.55	BUSH, rubber		2	
6	460-130	\$0.75	WASHER, cupped		2	
7	460-115	\$1.60	SPACER		2	
8	460-110	\$2.95	CAP NUT, valve cover		2	
9	460-100	\$13.95	CAP, metal, w/ cable		1	
	460-145	\$13.95	CAP, chromed, without cable		1	
	460-125	\$9.95	CAP, plastic (non-vented)	1098 - 1275	1	
	460-102	\$17.95	CAP, plastic (vented), OE type	1275	1	
	460-105	NA	CAP, plastic (vented), replacement	1275	1	
10	408-800	\$3.95	VALVE COVER PLATE, MG	} aluminum plates	1	
	408-900	\$4.75	VALVE COVER PLATE, Austin		1	
	408-810	\$4.95	VALVE COVER PLATE, patent		1	
	458-765	\$0.45	RIVET, aluminum plates		A/R	
	215-620	\$2.95	VALVE COVER PLATE, MG	} self adhesive mylar	1	
	031-232	\$3.45	VALVE COVER PLATE, Austin		1	
	215-625	\$2.95	VALVE COVER PLATE, patent		1	
12	328-605	\$1.20	STUD, thermostat housing	for housings #13 & 15	3	
	328-606	\$1.00	STUD, thermostat housing	for housing #14	3	
13	460-890	\$22.95	ELBOW, water outlet	948	1	
	460-855	\$35.95	ELBOW, water outlet	1098 - 1275 vert. rad.	1	
14	460-895	\$16.95	ELBOW, water outlet	1275 cross-flow rad.	1	
15	460-885	NA	ELBOW, water outlet	12CD, CJ & 12VS87Z	1	
16	296-380	\$0.60	GASKET, thermostat		1	
17			COOLING SYSTEM, see pages 14-15			
18	434-535	\$19.95	ADAPTOR, bypass (also used on early orig. water pumps)		1	
20	329-705	\$2.80	PEDESTAL STUD, short	948 - 1098	2	
	329-710	\$2.85	PEDESTAL STUD, short	1275	2	
21	329-700	\$1.95	PEDESTAL STUD, long		2	
	310-290	\$0.65	NUT for pedestal studs		4	
22	328-900	\$1.75	STUD, manifold		6	
23	310-140	\$0.30	NUT, manifold stud, steel	} alternatives	6	
	311-540	\$0.95	NUT, manifold stud, brass		6	
24	324-365	\$0.95	WASHER, inlet manifold		4	
25	372-371	\$1.38	FERRULE, inlet manifold locating	from 10CG 18628 thru 10CC	2	
26	460-604	\$159.95	TAPPET SET (8 specially selected tappets properly sized, hardened, crowned, etched, & micro-polished, with lube)		1	
	460-605	NA	TAPPET		8	
27	460-625	\$14.95	PUSH ROD	948 & 1098	8	
	460-635	\$7.95	PUSH ROD	1275	8	

No.	Part No.	Price (each)	Description	Application	Qty. Req.
28	433-850*	\$12.95	ROCKER ARM, sintered, replacement		8
These sintered rocker arms are slightly porous and self-lubricating once soaked in oil. They are not bushed.					
	433-840*	\$19.95	ROCKER ARM, forged, replacement		8
29	330-495	\$1.95	BUSH, forged rocker arms		8
Bushes must have oil holes drilled after installation, and must be reamed to fit the rocker shaft.					
* Note: Original rocker arms, stamped or forged, are not available. Either of the replacement rocker arms may be used in sets of eight. We do not advise mixing original and replacement rocker arms.					
30	433-870	\$1.50	NUT, adjuster locking	original rocker arms	8
	310-150	\$0.85	NUT, adjuster locking	replacement rocker arms	8
31	433-860	\$13.95	ADJUSTER	original rocker arms	8
	460-260	\$2.30	ADJUSTER	replacement rocker arms	8
32	451-455	\$18.95	SHAFT, rocker arm		1
35	460-270	\$1.95	SCREW, rocker shaft locating		1
36	433-880	NA	PLATE, screw retaining		1
37	297-635	\$0.95	SEAL, valve stem, umbrella	1275 intake only	4
38	297-650	\$0.45	SEAL, valve stem, o-ring	948 & 1098	8
40	423-275	\$2.25	VALVE GUIDE, intake & exhaust	} 948 & 1098	8
	423-290	\$5.50	VALVE GUIDE, manganese-bronze		8
	423-285	\$2.60	VALVE GUIDE, intake & exhaust	} 1275	8
	423-295	\$5.50	VALVE GUIDE, manganese-bronze		8
41	423-460	\$26.95	VALVE SPRING SET*	948* & 1098	1
	423-470	\$22.95	VALVE SPRING SET	1275	1
*For early 948 with single springs, use only outer springs in set.					
42	326-165	NA	SPRING CLIP	} 948 & 1098	8
43	460-485	\$2.10	VALVE COTTER		16
	460-535	\$4.45	VALVE COTTER	1275	16
44	460-552	\$5.65	COLLAR, valve retainer	948-1098	8
	460-556	\$10.95	COLLAR, valve retainer	1275	8
45	460-565	\$2.45	CUP (used with double springs only)		8
46	423-195	\$8.95	INTAKE VALVE 1.094" head dia. *, stem A	} 948 (9C engine) Bugeye	4
	423-175	\$7.95	INTAKE VALVE 1.156" head dia. *, stem A		} 948 (9CG) & 1098 to 10CG 14877
	423-185	\$7.95	INTAKE VALVE 1.215" head dia. *, stem A	} 1098 from 10CG 14878 & 10CC	
	423-190	\$8.95	INTAKE VALVE 1.313" head dia. *, stem B		} 1275
47	423-320	\$9.95	EXHAUST VALVE 1.000" head dia. *, stem A	} 948 & 1098	
	423-315	NA	EXHAUST VALVE, stellite 1.000" head dia. *, stem A		4
	423-325	NA	EXHAUST VALVE, O/S 1.098" head dia. *, stem A		4
	423-330	\$9.95	EXHAUST VALVE 1.156" head dia. *, stem B		} 1275
	423-335	\$14.95	EXHAUST VALVE, stellite face	4	
* Valve head diameters may vary by .005" or more due to manufacturing tolerances.					
48	361-065	\$6.95	ADAPTER, temperature gauge		1
49	324-805	\$1.55	WASHER, temp. gauge adapter		1

LOCAL & OVERSEAS: 805-681-3400

FAX: 805-692-2525 www.mossmotors.com

MOSS

Internal Engine 948 - 1098 - 1275

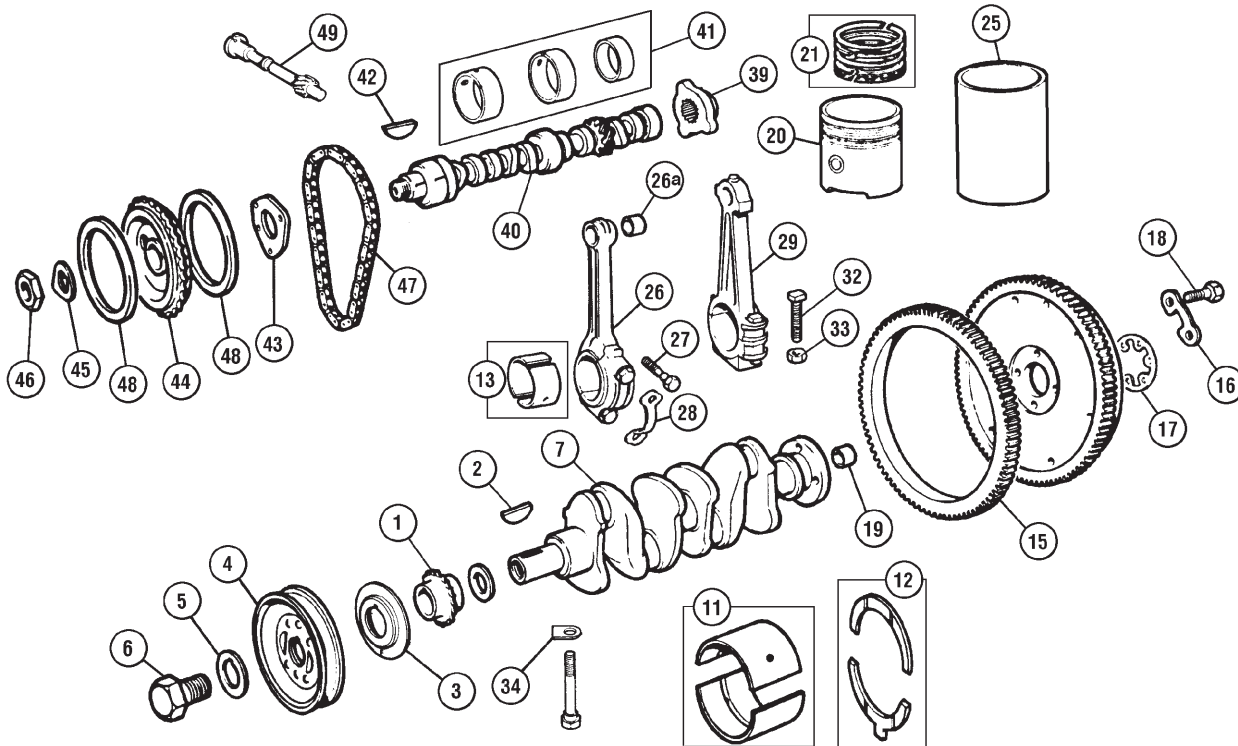

No.	Part No.	Price (each)	Description	Application	Qty. Req.
	328-635†	\$22.95	ENGINE LOCKTAB SET	948 & 1098	1
	328-620†	\$15.95	ENGINE LOCKTAB SET	1275	1
† Note: Locktab sets include all items marked † below.					
1	460-435	\$12.95	CRANK SPROCKET, single	948 - 1098	1
	460-445	\$19.95	CRANK SPROCKET, double	1275	1
2	327-210	\$5.75	KEY		1
3	433-890	\$3.55	OIL THROWER		1
4	460-455	\$92.95	PULLEY	948 - 1098	1
	460-465	\$197.95	PULLEY	1275	1
5	460-470†	\$0.95	WASHER, lock tab		1
6	322-120	\$9.95	BOLT		1
7	451-565	NA	CRANKSHAFT	948	1
	451-570	NA	CRANKSHAFT	1098 (10CG)	1
	451-575	NA	CRANKSHAFT	1098 (10CC)	1
	451-585	NA	CRANKSHAFT	1275	1
11	425-105	\$32.95	MAIN BEARING SET, standard	} 948, 1.75" crank diameter Orig. 1.19" brg. width (see note below)	1
	425-110	\$32.95	MAIN BEARING SET, .010"		1
	425-115	\$32.95	MAIN BEARING SET, .020"		1
	425-120	\$35.95	MAIN BEARING SET, .030"		1
	425-125	NA	MAIN BEARING SET, .040"		1
Note: We and our suppliers now have only 1.067" wide bearings for 948 engines, which work fine. Bearings in the original width are no longer available.					
	425-160	\$37.95	MAIN BEARING SET, standard	} 1098(10CG) 1.75" crank diameter 1.067" max. brg. width	1
	425-165	\$37.95	MAIN BEARING SET, .010"		1
	425-170	\$37.95	MAIN BEARING SET, .020"		1
	425-175	\$37.95	MAIN BEARING SET, .030"		1
	425-180	\$37.95	MAIN BEARING SET, .040"		1
	425-130	\$32.65	MAIN BEARING SET, standard	} 1098(10CC) & 1275 2.00" crank diameter 0.985" max. brg. width	1
	425-135	\$32.65	MAIN BEARING SET, .010"		1
	425-140	\$32.65	MAIN BEARING SET, .020"		1
	425-145	\$32.65	MAIN BEARING SET, .030"		1
	425-155	\$32.65	MAIN BEARING SET, .040"		1
12	425-505	\$15.95	THRUST WASHER SET, standard	948	1
	425-520	\$8.50	THRUST WASHER SET, standard	} 1098 (10CG)	1
	425-525	NA	THRUST WASHER SET, .003"		1
	425-530	NA	THRUST WASHER SET, .010"		1
	425-535	\$10.95	THRUST WASHER SET, standard		} 1098 (10CC) & 1275
	425-540	\$14.95	THRUST WASHER SET, .003"	1	

No.	Part No.	Price (each)	Description	Application	Qty. Req.
13	425-805	\$34.95	ROD BEARING SET, standard		1
	425-810	\$34.95	ROD BEARING SET, .010"		1
	425-815	\$34.95	ROD BEARING SET, .020"		1
	425-820	\$34.95	ROD BEARING SET, .030"		1
	425-825	\$34.95	ROD BEARING SET, .040"		1
15	190-060	\$34.95	RING GEAR	948	1
	190-065	\$34.95	RING GEAR	1098	1
	190-070	\$34.95	RING GEAR	1275	1
16	460-405†	NA	LOCKTAB, flywheel	948 & 1098	2
17	460-415	\$3.80	LOCKTAB, flywheel	1275	1
18	322-500	\$1.05	BOLT, flywheel	948 & 1098	4
	322-505	\$1.85	BOLT, flywheel	1275	6
19	330-475	\$2.95	BUSHING, spigot	{ 948 thru most 1275 (5/8" O.D.)	1
	330-465	\$13.95	NEEDLE BEARING, spigot	late 1275 (3/4" O.D.)	1
20	420-100	\$232.95	PISTON SET, standard	} 948 C.R. 8.3:1	1
	420-105	\$232.95	PISTON SET, .020"		1
	420-110	\$232.95	PISTON SET, .030"		1
	420-115	\$232.95	PISTON SET, .040"		1
	420-120	\$232.95	PISTON SET, .060"		1
	420-125	\$294.95	PISTON SET, standard	} 1098 C.R. 8.9:1	1
	420-130	\$294.95	PISTON SET, .020"		1
	420-135	\$294.95	PISTON SET, .030"		1
	420-140	NA	PISTON SET, .040"		1
	420-145	NA	PISTON SET, .060"		1
	420-150	\$206.95	PISTON SET, standard	} 1275 C.R. 8.8:1	1
	420-155	\$206.95	PISTON SET, .020"		1
	420-160	\$206.95	PISTON SET, .030"		1
	420-165	\$206.95	PISTON SET, .040"		1
	420-170	\$206.95	PISTON SET, .060"		1
21	421-620	\$49.95	RING SET, standard	} 948 4-ring (.070" & .125" width)	1
	421-625	\$49.95	RING SET, .020"		1
	421-630	\$49.95	RING SET, .030"		1
	421-635	\$49.95	RING SET, .040"		1
	421-640	\$49.95	RING SET, .060"		1

moss

MOSS MOTORS, LTD. TOLL-FREE ORDERS 1-800-667-7872

No.	Part No.	Price (each)	Description	Application	Qty. Req.
421-645	\$68.95	RING SET, standard	} 948 5-ring (.070" & .125" width)	948	1
421-650	\$68.95	RING SET, .020"			1
421-655	\$68.95	RING SET, .030"			1
421-660	\$68.95	RING SET, .040"			1
421-665	\$68.95	RING SET, .060"			1
421-670	\$47.95	RING SET, standard	} 1098 4-ring	1098	1
421-675	\$47.95	RING SET, .020"			1
421-680	\$47.95	RING SET, .030"			1
421-685	\$47.95	RING SET, .040"			1
421-690	\$47.95	RING SET, .060"			1
421-695	\$60.95	RING SET, standard	} 1098 5-ring	1098	1
421-700	\$60.95	RING SET, .020"			1
421-705	\$60.95	RING SET, .030"			1
421-710	\$60.95	RING SET, .040"			1
421-715	\$60.95	RING SET, .060"			1
421-720	\$47.95	RING SET, standard	} 1275 4- ring These fit only original factory pistons	1275	1
421-725	\$47.95	RING SET, .020"			1
421-730	\$47.95	RING SET, .030"			1
421-735	\$47.95	RING SET, .040"			1
421-740	\$47.95	RING SET, .060"			1
421-750	\$64.95	RING SET, standard	} 1275 3- ring These fit replacement AE pistons #21251	1275	1
421-755	\$64.95	RING SET, .020"			1
421-760	\$64.95	RING SET, .030"			1
421-765	\$64.95	RING SET, .040"			1
421-770	\$64.95	RING SET, .060"			1
25	426-090*	\$45.95	SLEEVE, cylinder, standard	948	4
	426-110*	\$46.95	SLEEVE, cylinder, standard	1098	4
	426-120*	\$46.95	SLEEVE, cylinder, standard	1275	4
* Note: Cylinder sleeves require installation by a professional machine shop.					
26	837-310	NA	CONNECTING ROD, # 1 & 3	} 948 (not illus.)	2
	837-300	\$26.95	CONNECTING ROD, # 2 & 4		2
	837-350	NA	CONNECTING ROD, # 1 & 3	} 1098 (illus.)	2
	837-360	NA	CONNECTING ROD, # 2 & 4		2
26a	422-085	\$9.10	BUSH SET (4)	1098	1
27	837-330	\$16.95	BOLT, connecting rod	} 948 & 1098	8
28	837-335†	\$0.65	LOCK TAB		4
	322-480	\$2.35	BOLT, wrist pin	948	4
29	837-320	NA	CONNECTING ROD SET	} 1275	1
32	837-340	\$15.95	BOLT, connecting rod		8
33	837-345	\$3.40	NUT, connecting rod		8
	322-838	\$141.95	BOLT & NUT SET, con rod, high tensile		1
34	324-815†	\$0.50	LOCK WASHER, main cap bolt		6
39	435-670	NA	FLANGE, star drive	1275	1
40	451-440	\$125.95	CAMSHAFT, stock	948	1
	NA	CAMSHAFT, stock	1098	1098	1
	NA	CAMSHAFT, stock	1275	1275	1
	451-435	\$463.95	CAMSHAFT, mildly improved for street use Must use 1275 stardrive oil pump & flange (NLS). If you don't have the stardrive flange, you cannot use this camshaft.	948-1275	1
41	NA	CAM BEARING, single	948 (9C engine)	948	1
	Not available. Use set 424-980 for 1275, discard extra bearings.				
	424-975	\$16.95	CAM BEARING SET	948 (9CG) & 1098	1
	424-980	\$31.95	CAM BEARING SET	1275	1
42	327-190	\$0.85	KEY, camshaft	948	1
43	460-475	\$16.95	PLATE, cam locating	948 & 1098	1
44	460-525	\$19.95	CAM SPROCKET, single row	948 & 1098	1
	833-430	\$26.95	CAM SPROCKET, double row	1275	1
45	460-550†	\$0.95	LOCK PLATE	948	1
46	311-500	\$4.50	NUT	1275	1
47	460-595	\$8.95	TIMING CHAIN, single row	948 & 1098	1
	460-590	\$9.95	TIMING CHAIN, double row	1275	1
48	460-495	\$2.95	TENSIONER RING	948 & 1098	2
49	460-640	\$65.95	SPINDLE, distributor drive	948	1

948 - 1098 - 1275 - Internal Engine

SPRITE-MIDGET

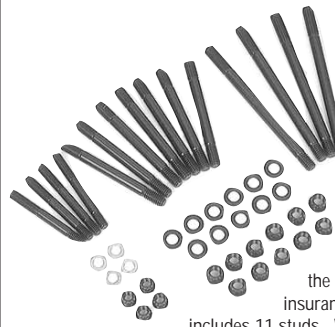

Heavy Duty Engine Bolts and Stud Kits

Keep your engine together with these heavy duty, high tensile strength precision ground engine hardware kits which include special hardened washers and 12-point nuts. These premium quality fastener kits are perfect for the racer, road warrior, or anyone who wants added insurance against mechanical failure. The head stud kit includes 11 studs. While factory engines used 9, some engines

have been modified to use two more. Head studs and main cap studs are rated at 190,000 p.s.i., rod bolts at 180,000 p.s.i.

948, 1098, 1275 Head Stud Kit	322-998	\$208.95
1275 Main Bearing Cap Stud Kit	322-888	\$94.95
1275 Connecting Rod Bolt Kit	322-838	\$141.95

Engine Locktab Sets

Save the hassle of ordering all the separate locktabs on your engine with these sets, which include all locktabs in the listings to the left marked †.

948-1098 Locktab Set	328-635	\$22.95
1275 Locktab Set	328-620	\$15.95



Vernier Cam Sprocket Kit

If you are serious about making your engine run "just right", this is one upgrade you should be sure to install. This adjustable cam sprocket enables you to time your cam perfectly to factory cam timings, or to change the factory cam timing on seriously modified engines. Kit includes adjustable cam sprocket, duplex crank sprocket, and duplex chain.

Sprocket Kit 460-385 \$269.95



1275 Aluminum Flywheel

Improved throttle response is a main benefit of using this high strength but light weight steel-faced alloy flywheel.

461-005 \$549.95



Speedi-Sleeve

Timing Cover Seal. (use on illustration #4)

When a new seal cannot compensate for excessive damage, this ultra-thin sleeve provides a "new" sealable surface. Instructions and installation tool are included.

520-515 \$34.45



LOCAL & OVERSEAS: 805-681-3400

FAX: 805-692-2525 www.mossmotors.com

MOSS

Midget 1500 Engine

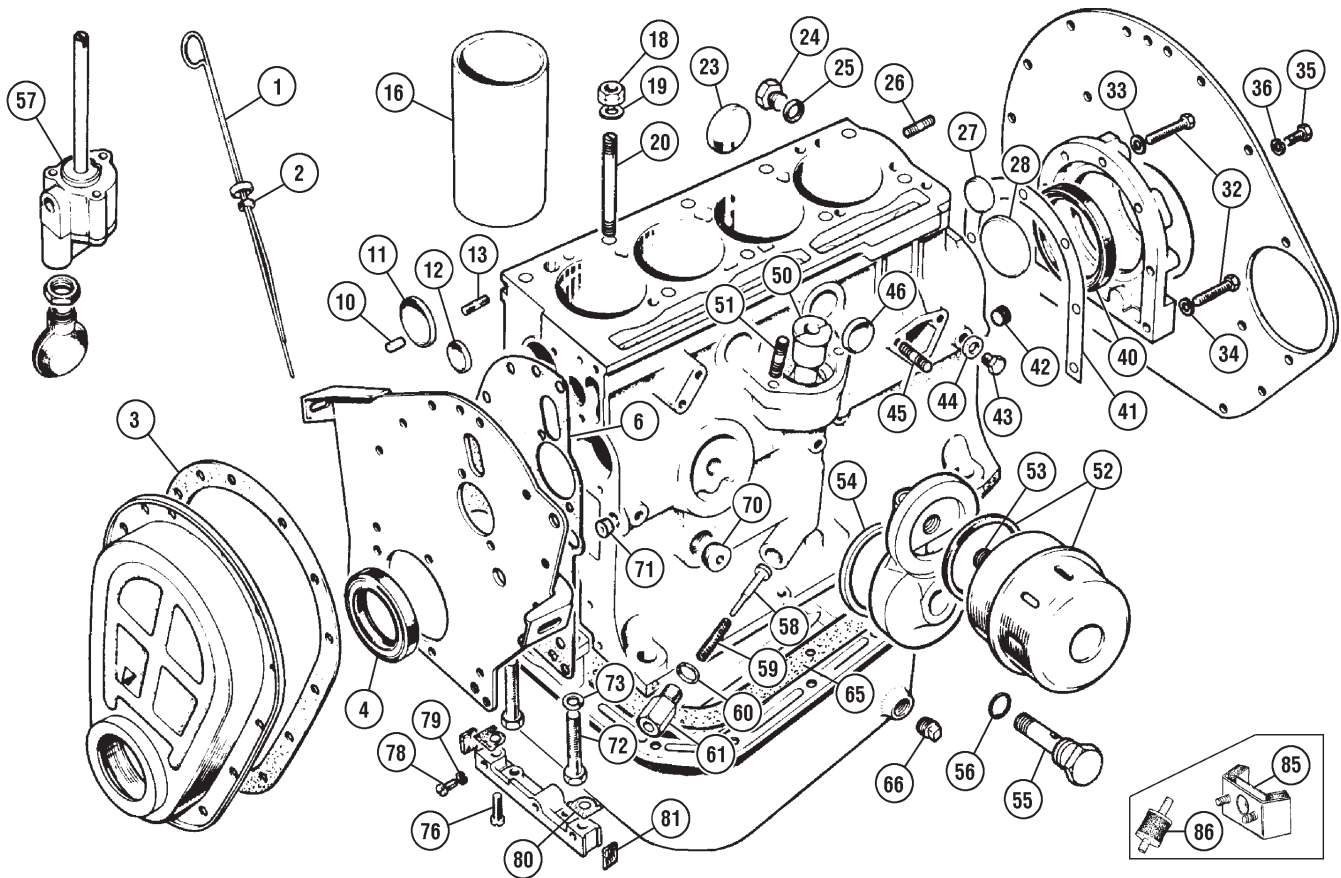

No.	Part No.	Price (each)	Description	Application	Qty. Req.
	694-151	\$29.35	GASKET SET, lower engine, "Payen" brand		1
	694-152	\$18.95	GASKET SET, lower engine (various manufacturers)		1
	694-143	\$46.95	HEAD GASKET SET, "Payen" brand		1
	694-144	\$27.95	HEAD GASKET SET (various manufacturers)		1
1	451-205	NA	DIPSTICK		1
2	697-020	\$0.95	SEAL, felt		1
3	697-115	\$4.55	GASKET, timing cover		1
4	520-430	\$5.95	OIL SEAL, timing cover		1
6	695-105	\$1.70	GASKET, front engine plate		1
10	325-215	\$0.95	DOWEL PIN		2
11	328-205	\$1.95	CORE PLUG, large		1
12	319-015	\$0.55	CORE PLUG, small		1
13	328-654	\$1.95	STUD		1
16	426-130	NA	LINER, cylinder	(requires machining)	4
18	310-045	\$2.00	NUT, head stud		10
19	324-860	\$0.35	WASHER, head stud		10
20	329-615	\$4.55	STUD, cylinder head		10
23	328-205	\$1.95	CORE PLUG		3
24	328-445	\$6.10	PLUG, drain		1
25	324-670	\$0.60	WASHER for plug		1
26	328-900	\$1.75	STUD		3
27	328-215	\$0.85	CORE PLUG, small		1
28	328-225	\$1.00	CORE PLUG, large		1
32	320-695	\$0.75	BOLT, seal housing to block		7
33	NA		WASHER, copper		1
34	365-730	\$0.20	LOCKWASHER		6
35	322-040	\$0.45	BOLT		7
36	365-730	\$0.20	LOCKWASHER		7
40	520-320	\$3.95	OIL SEAL, rear		1
41	697-485	\$0.80	GASKET, seal housing to block		1
42	328-245	\$2.35	PLUG, oil gallery, rear		1
43	322-345	\$0.25	PLUG, oil gallery, side		4
44	NA		WASHER, copper		4
45	328-654	\$1.95	STUD, fuel pump mounting		2
46	328-215	\$0.85	CORE PLUG		2
50	836-135	\$59.95	BUSH, distributor/oil pump drive		1
51	328-654	\$1.95	STUD, distributor mounting		2
52	950-025	\$10.60	OIL FILTER w/sealing ring, "Crosland" brand		1
	950-525	\$8.85	OIL FILTER w/sealing ring, various manufacturers		1
53	833-455	\$4.55	ADAPTOR, oil filter to filter head		1

No.	Part No.	Price (each)	Description	Application	Qty. Req.
54	520-400	\$0.95	SEAL, filter head to block		1
55	NA		BOLT, filter head		1
56	466-515	\$0.75	"O" RING		1
57	836-130	\$119.95	OIL PUMP with screen		1
58	836-545	\$8.95	PISTON, oil pressure relief valve		1
59	329-295	\$1.95	SPRING		1
60	315-005	\$0.60	WASHER, copper		1
61	328-065	\$9.95	HOUSING, oil pressure relief valve		1
65	694-160	\$2.95	GASKET, oil pan		1
66	328-340	\$1.35	PLUG, oil drain		1
70	328-425	\$2.25	PLUG		1
71	328-245	\$2.35	PLUG, oil gallery		1
72	266-580	\$1.95	BOLT, main bearing cap		6
73	324-250	\$0.25	LOCKWASHER		6
76	323-015	\$1.70	SCREW		2
78	320-815	\$1.30	BOLT		2
79	365-730	\$0.20	LOCKWASHER		2
80	697-490	\$0.55	GASKET, front sealing block		2
81	697-495	\$1.65	PACKING PIECE, wood		2
85	810-120	\$21.95	MOUNT, engine		2
86	810-140	\$5.95	MOUNT, transmission		2

Important Note:

Before ordering parts for your 1500 engine, make sure someone hasn't put a Spitfire 1500 engine in your Midget. While they are the same basic engines, there are some differences in fuel pumps, distributors, and some small parts which can cause confusion and frustration if the wrong parts are obtained. The real Midget engine numbers have a "FP" prefix, while the Spitfire engine numbers begin with "FM".



MOSS MOTORS, LTD. TOLL-FREE ORDERS 1-800-667-7872

Midget 1500 Engine

SPRITE-MIDGET

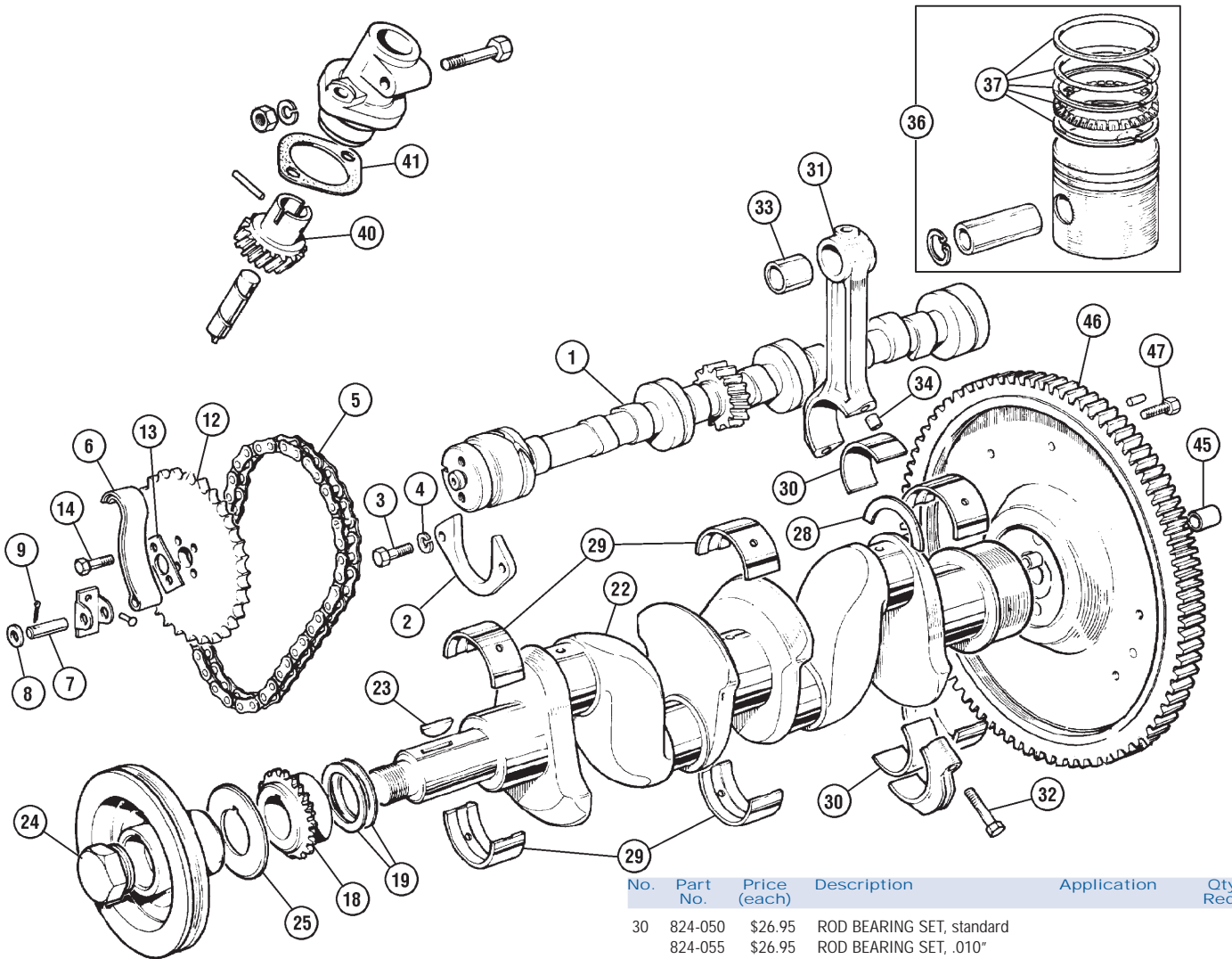

No.	Part No.	Price (each)	Description	Application	Qty. Req.
1	851-330	\$302.95	CAMSHAFT		1
2	838-035	\$13.95	RETAINER, camshaft		1
3	322-540	\$0.75	BOLT for retainer		1
4	365-730	\$0.20	LOCKWASHER		2
5	832-110	\$8.95	TIMING CHAIN		1
6	832-260	\$4.85	TENSIONER, timing chain		1
7	832-265	\$1.95	PIN, tensioner pivot		1
8	324-870	\$0.45	WASHER, plain		1
9	325-475	\$0.95	COTTER PIN		1
12	838-205	\$30.95	SPROCKET, camshaft		1
13	838-025	\$1.85	LOCKPLATE, cam sprocket		1
14	322-395	\$0.65	BOLT, sproket to camshaft		2
18	837-105	\$36.95	SPROCKET, crankshaft		1
19	837-025	\$1.60	SHIM, .004"	A/R	1
	837-035	\$1.75	SHIM, .006"	A/R	1
22	851-350	NA	CRANKSHAFT		1
23	327-220	\$9.25	KEY		1
24	322-910	\$13.95	NUT, crankshaft		1
25	837-055	\$11.95	OIL DEFLECTOR		1
28	828-030	\$8.50	THRUST WASHER SET, standard		1
	828-035	\$6.80	THRUST WASHER SET, .005"		1
	828-040	\$9.95	THRUST WASHER SET, .015"		1
29	822-040	\$25.95	MAIN BEARING SET, standard		1
	822-050	\$25.95	MAIN BEARING SET, .010"		1
	822-060	\$25.95	MAIN BEARING SET, .020"		1
	822-070	\$23.95	MAIN BEARING SET, .030"		1
	822-080	NA	MAIN BEARING SET, .040"		1

No.	Part No.	Price (each)	Description	Application	Qty. Req.
30	824-050	\$26.95	ROD BEARING SET, standard		1
	824-055	\$26.95	ROD BEARING SET, .010"		1
	824-060	\$26.95	ROD BEARING SET, .020"		1
	824-065	\$26.95	ROD BEARING SET, .030"		1
	824-070	\$24.95	ROD BEARING SET, .040"		1
31	837-740	\$188.95	CONNECTING ROD, reconditioned		4
32	320-455	\$5.05	BOLT, connecting rod		8
33	829-030	\$3.95	BUSH, wrist pin		4
34	837-745	\$1.45	TUBE, locating		8
36	814-451	\$230.95	PISTON SET, standard	} 9:1 CR, thru 1976 except CA	1
	814-455	\$254.95	PISTON SET, .020"		1
	814-460	\$254.95	PISTON SET, .030"		1
	814-465	\$254.95	PISTON SET, .040"		1
	814-470	\$249.95	PISTON SET, standard	} 7.5:1 CR CA all years Federal 1977-on	1
	814-475	\$249.95	PISTON SET, .020"		1
	814-480	\$249.95	PISTON SET, .030"		1
	814-485	NA	PISTON SET, .040"		1
37	817-650	\$59.95	PISTON RING SET, standard.		1
	817-655	\$59.95	PISTON RING SET, .020"		1
	817-660	\$59.95	PISTON RING SET, .030"		1
	817-665	\$59.95	PISTON RING SET, .040"		1
40	836-640	\$17.95	GEAR, oil pump & distributor drive		1
41	697-145	\$0.95	GASKET, .006"		A/R
45	330-510	\$3.95	PILOT BUSHING		1
46	590-030	\$34.95	RING GEAR		1
47	320-790	\$4.95	BOLT, flywheel to crankshaft		4

Speedi-Sleeve

Timing Cover Seal. For use on Crank Pulley

When a new seal cannot compensate for excessive damage, this ultra-thin sleeve provides a "new" sealable surface. Instructions and installation tool are included.

520-510 \$40.95



LOCAL & OVERSEAS: 805-681-3400

FAX: 805-692-2525 www.mossmotors.com

MOSS

Midget 1500 Cylinder Head

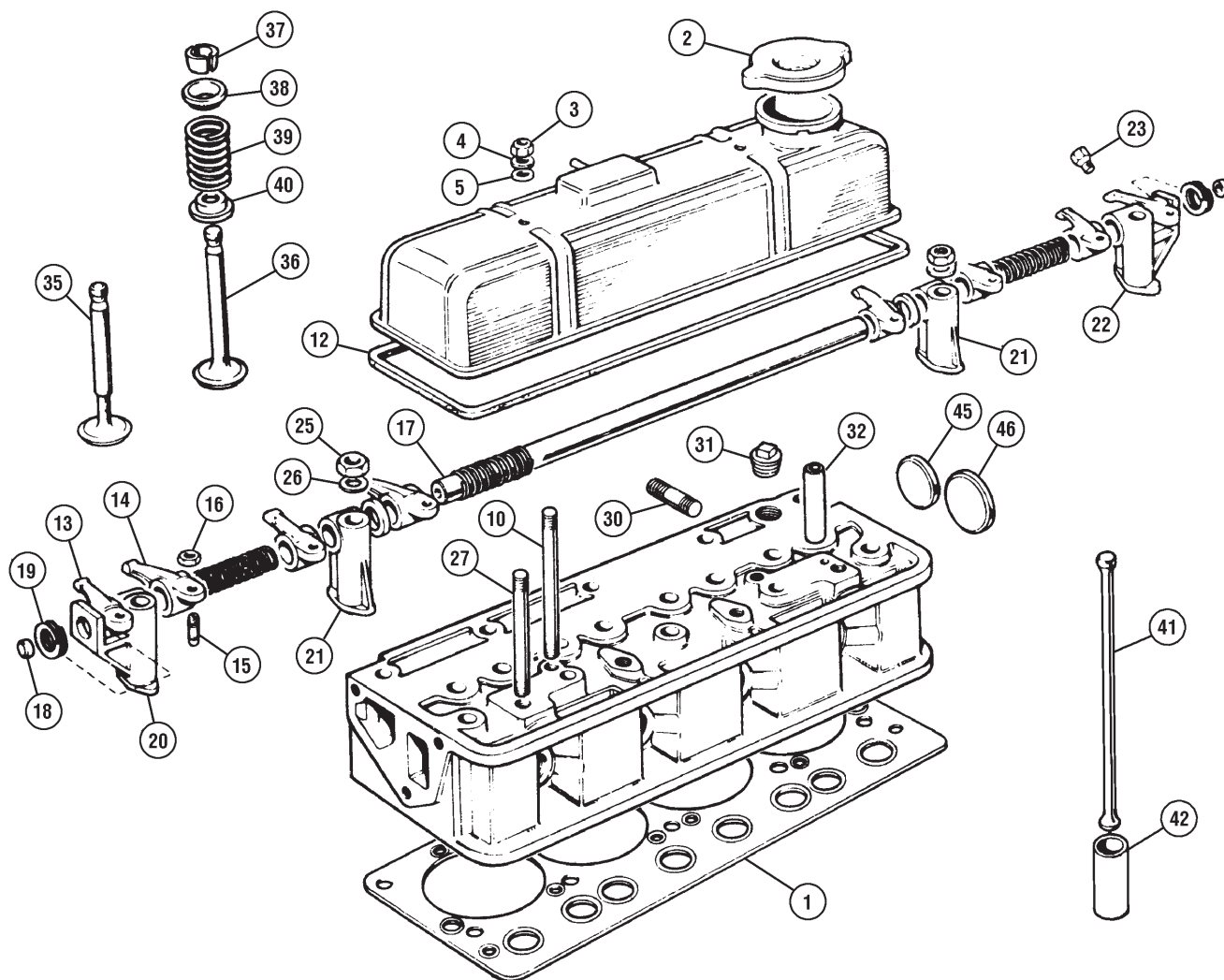

No.	Part No.	Price (each)	Description	Application	Qty. Req.
	694-143	\$46.95	HEAD GASKET SET, "Payen" brand		1
	694-144	\$27.95	HEAD GASKET SET (various manufacturers)		1
1	694-110	\$14.95	HEAD GASKET		1
2	834-765	\$9.95	CAP, oil filler		1
3	310-105	\$0.45	NUT, valve cover	} thru 1976	2
4	365-720	\$0.30	WASHER, plain		2
5	324-680	\$0.35	WASHER, fiber		2
	072-019	\$4.55	CAP NUT	} from 1977-on	2
	072-020	\$2.65	WASHER		2
	071-092	\$0.95	"O" RING		2
9	328-675	\$1.95	STUD, valve cover	thru 1976	2
		NA	STUD, valve cover	from 1977-on	2
12	694-100	\$4.60	GASKET, valve cover		1
13	839-110	\$14.95	ROCKER ARM, #1,3,5,7		4
14	839-120	\$14.95	ROCKER ARM, #2,4,6,8		4
15	839-030	\$4.35	ADJUSTER, valve		8
16	310-150	\$0.85	NUT for adjuster		8
17	851-320	\$29.95	ROCKER SHAFT		1
18	839-100	\$1.95	END PLUG		2
19	329-860	\$2.25	SPRING, front & rear pedestals		2
20	831-585	NA	PEDESTAL, front		1
21	831-590	\$39.95	PEDESTAL, intermediate		2
22	831-595	NA	PEDESTAL, rear		1
23	323-215	\$1.10	SCREW		1
25	310-050	\$0.50	NUT, rocker shaft pedestal		4
26	315-010	\$0.15	WASHER		4

No.	Part No.	Price (each)	Description	Application	Qty. Req.
27	328-665	\$1.95	STUD, rocker shaft pedestal		4
30	328-660	\$1.05	STUD, exhaust manifold		2
	328-650	\$1.95	STUD, inlet & exhaust manifolds		6
31	328-340	\$1.35	PLUG, threaded		1
32	830-000	\$2.10	VALVE GUIDE, inlet & exhaust, stock type		8
	830-015	\$5.50	VALVE GUIDE, inlet & exhaust, manganese bronze		8
35	821-250	\$7.95	VALVE, inlet		4
36	821-260	\$10.95	VALVE, exhaust		4
37	831-530	\$3.95	SPLIT COTTER, valve retaining		16
38	821-210	NA	COLLAR, upper		8
39	821-270	\$29.95	VALVE SPRING SET		1
40	821-240	NA	COLLAR, lower		8
41	838-530	\$4.95	PUSHROD		8
42	838-300	\$6.95	TAPPET		8
45	328-215	\$0.85	CORE PLUG, small		1
46	328-235	\$1.00	CORE PLUG, large		1

MOSS MOTORS, LTD.
 TOLL-FREE ORDERS **1-800-667-7872**



Oberg Tilt Lift

It never fails. No matter what angle you hang an engine from its sling, it will be wrong. Unfortunately, most cars require the engine to be installed in an arc. This chore is hard enough with help, but it's nearly impossible without. Tilt Lift is a product which enables you to remove or install an engine alone. Tilt Lift allows easy adjustment of an engine's lift angle through a full 90 degrees of movement. Adjustment is easy, employing your 1/2" ratchet, and the 2,000 pound capacity – with a 3:1 safety load factor – is more than enough for any modern engine/tranny combination. A positive lock ensures the engine stays put. Tilt Lift's all steel construction ensures durability,

and its small size (weighing only four pounds) makes it perfect for small work areas. The mounting cleats are adaptable to any engine. Reduce the risk of personal injury, or damage to your car with a Tilt Lift.

386-730 \$75.95

"Ultra Slick" Engine Assembly Lube

The most critical time for dangerous wear during an engine's life is during initial start-up. Protect your rebuild (and all of those expensive parts) by using "Ultra Slick" during assembly of camshafts, lifters, engine bearings, timing components, valves & guides and rocker shaft assemblies. It's the best insurance available.

221-565 \$6.25



Spridget A-Series Alloy Cylinder Head

Use unleaded fuel with confidence, and increase your engine's efficiency and performance. These light-weight (9 lbs.) high strength aluminum alloy cylinder heads run cooler, allow higher compression ratios, and have a greater than 35% increase in flow rate over stock heads. Heads come with silicon-bronze valve guides and hardened valve seats. These require 1275 valves, springs, and retainers. 12mm spark plugs are required (use part # 451-890). All of which must be purchased separately. (Quantities required in parenthesis). These heads do not have air injection ports, and therefore may not be used for street use on cars originally fitted with air pumps.

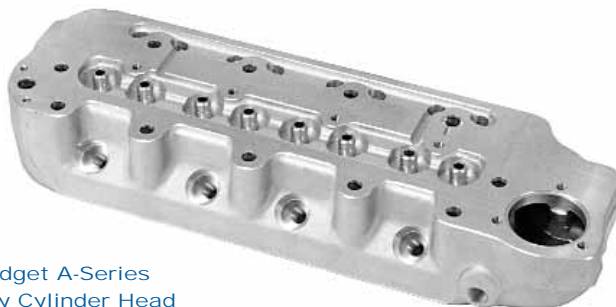

Alloy Cylinder Head	451-875	\$1,049.95
Intake Valve (4)	423-190	\$8.95
Exhaust Valve (4)	423-335	\$14.95
Valve Spring Set (1)	423-470	\$22.95
Valve Collar (8)	460-556	\$10.95
Valve Cotter (16)	460-535	\$4.45
Spark Plug (4)	451-890	\$3.95

Engine Timing Degree Wheel

To get the best performance from your engine, it's essential to ensure exact camshaft timing. Use our handy plastic degree wheel to check timing when installing a new camshaft.

384-910 \$6.90



"Hylomar HPF" Gasket Dressing and Sealer

Scraping off firmly stuck old gaskets is a thing of the past when you use Hylomar. Unlike most older types of gasket dressing, Hylomar will not ever harden, ensuring easy disassembly even years later. Hylomar holds gaskets in place during assembly and allows repositioning, while providing an instantly useable seal after assembly with proper torque. Hylomar is resistant to all automotive fluids, including gasoline, and is useable in temperatures from -60° to +600°F.

221-555 \$7.95



Cam Lube

The first few minutes of running are critical to the life of your new camshaft and lifters. We simply cannot overstate the importance of proper lubrication during this period. To make sure your new cam lasts a long time, use our cam lube when installing a new camshaft or lifters.

221-570 \$10.95

Engine Paint

The right paint in the right color is the only kind to use on your freshly rebuilt engine. We invested a lot of time and effort to develop the correct shade of olive green for Sprigets. One can is enough to paint a properly prepared engine. (Black is not Moss "Classic Color")

Dark Olive Green 220-580 \$14.95
Black (1972-'80) 220-575 \$8.95



Magnetic Drain Plug

Guard your engine! Our magnetic oil drain plug helps protect your engine by collecting metallic particles before they get fed through your oil system. Fits your gearbox, too!

948-1275 328-282 \$4.95
Midget 1500 328-356 \$3.25

Cooling System

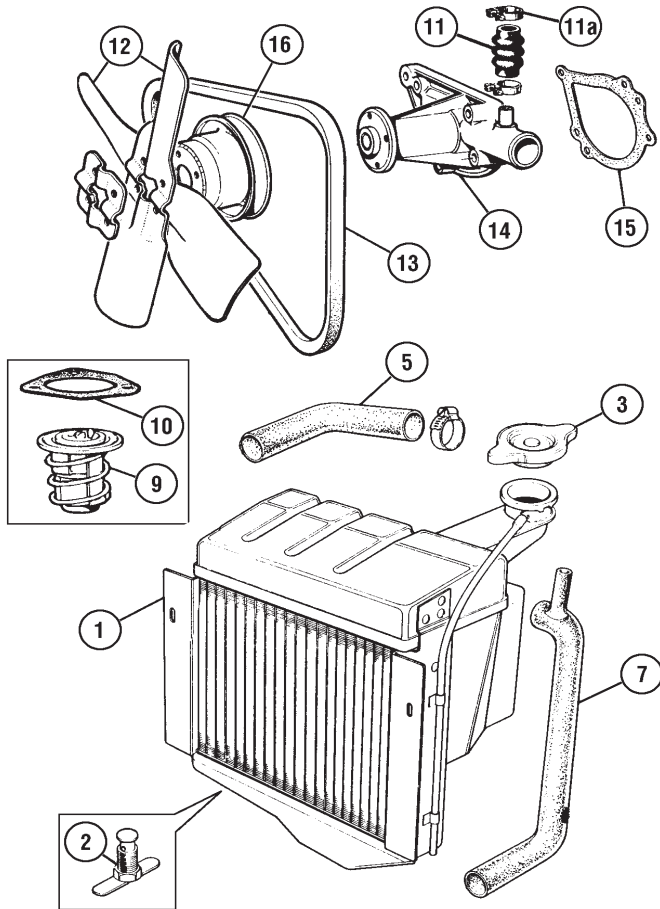

No.	Part No.	Price (each)	Description	Application	Qty. Req.
1	459-730	\$199.95	RADIATOR, vertical-flow	} to AH (c)72033 } to MG (c)60440	1
2	660-020	\$7.50	DRAIN TAP		1
3	583-004	\$4.80	CAP		1
5	470-370	\$6.20	HOSE, top	948 & 1098	1
	470-375	\$7.25	HOSE, top	{ 1275 to AH (c)72033 MG (c)60440	1
7	470-380	\$10.45	HOSE, bottom	948 & 1098	1
	470-385	\$14.95	HOSE, bottom	{ 1275 to AH (c)72033 MG (c)60440	1
9	434-180	\$4.95	THERMOSTAT, 165°, hot climates		1
	434-189	\$4.95	THERMOSTAT, 180°, normal		1
	434-190	\$4.95	THERMOSTAT, 195°, cold climates		1
10	296-380	\$0.60	GASKET, thermostat housing		1
11	434-530	\$2.70	HOSE, bypass		1
11a	262-200	\$0.90	CLAMP		2

Check the bypass hose between the cylinder head and the water pump frequently. It is easy to mistake a leaky bypass for a faulty water pump as the leak in both cases will run down the side of the pump. Replace the bypass hose when replacing head gaskets or water pump.

12	434-550	\$20.95	FAN BLADE, sold individually		2
13	460-990	\$6.00	FAN BELT	948	1
	460-875	\$4.15	FAN BELT	1098 & 1275 thru 1967	1
14	434-540	\$32.95	WATER PUMP	948 thru 1275 (e)12CD/H1745	1
	434-545	\$41.95	WATER PUMP	1275 from (e)12CD/H1746	1
15	296-620	\$0.95	GASKET, water pump		1
16	NA		PULLEY, water pump		1

Lining up the various parts that use the radiator mounting bolts as support is easy when a tapered line-up tool is placed through the top holes to support one side while the opposite side is bolted. Install the top bolts first. Do not tighten any of the bolts until all four bolts are in place. The top bolts can be started using a deep well socket on a long extension with a nut in the socket to keep the bolt to the end of the socket. Most Spridgets have the two lower bolts missing. Get rid of a rattle or two by replacing them.

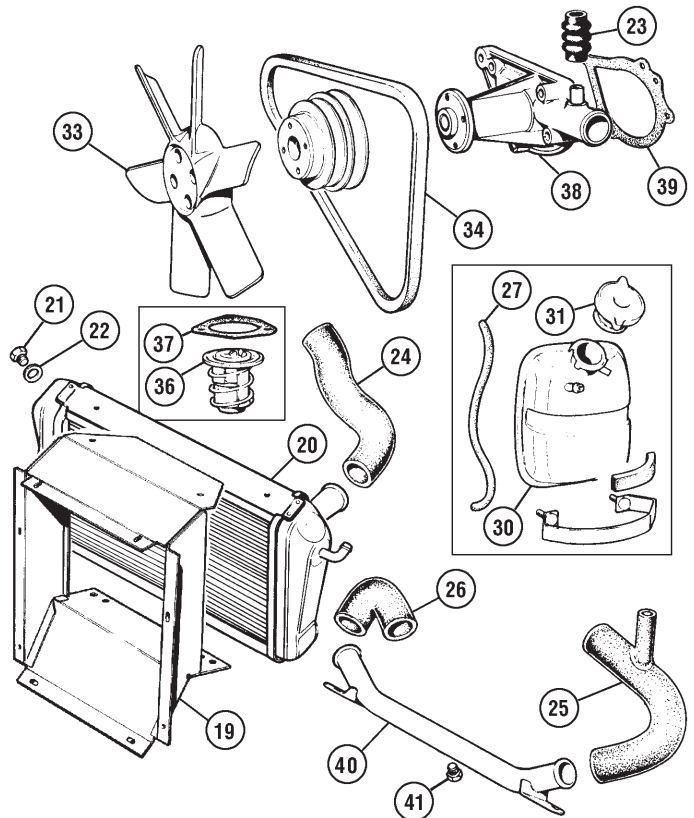

No.	Part No.	Price (each)	Description	Application	Qty. Req.
-----	----------	--------------	-------------	-------------	-----------

Cross-Flow System 1275 from AH (c)72034 and MG (c)60441

19	459-765	\$177.95	COWL, radiator		1
20	459-735	\$194.95	RADIATOR, cross-flow		1
21	459-760	\$6.50	PLUG		1
22	328-485	\$1.05	WASHER		1
23	434-530	\$2.70	HOSE, bypass		1
24	470-390	\$8.70	HOSE, top		1
25	470-395	\$9.50	HOSE, lower tube to pump		1
26	470-400	\$4.55	HOSE, radiator to lower tube		1
27	470-345	\$3.25	HOSE, radiator to expansion tank		1
30	459-690	NA	EXPANSION TANK		1
31	459-695	\$5.70	CAP, expansion tank		1
33	434-560	\$41.95	FAN, plastic		1
34	434-600	\$5.20	FAN BELT		1
36	434-180	\$4.95	THERMOSTAT, 160°, hot climates		1
	434-189	\$4.95	THERMOSTAT, 180°, normal		1
	434-190	\$4.95	THERMOSTAT, 195°, cold climates		1
37	296-380	\$0.60	GASKET, thermostat		1
38	434-545	\$41.95	WATER PUMP		1
39	296-620	\$0.95	GASKET, water pump		1
40	434-520	\$39.95	PIPE		1
41	319-100	NA	DRAIN PLUG		1

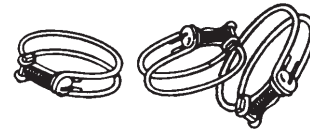

Wire Hose Clamps

326-475	7/16 to 9/16"	\$1.20
635-100	3/4 to 7/8"	\$1.75
635-060	7/8 to 15/16"	\$2.95
326-410	1 3/16 to 1 3/8"	\$1.90
326-465	1 1/4" to 1 7/16"	\$2.80
326-430	1 3/8 to 1 9/16"	\$1.30
326-440	1 7/16 to 1 5/8"	\$2.70
326-450	1 11/16 to 1 7/8"	\$2.75
031-724	1 7/8 to 2"	\$1.95
326-230	2 1/4 to 2 7/16"	\$2.40
326-460	2 13/32 to 2 5/8"	\$2.35

Water Wetter

Water Wetter is a wetting agent which helps coolant "bond" to the surfaces inside your cooling and heating system, increasing heat transfer efficiency. While your car can run up to 15° F cooler, your heater will run hotter! Highly recommended for all climates.

220-115 \$9.60



moss

MOSS MOTORS, LTD. 1-800-667-7872
TOLL-FREE ORDERS

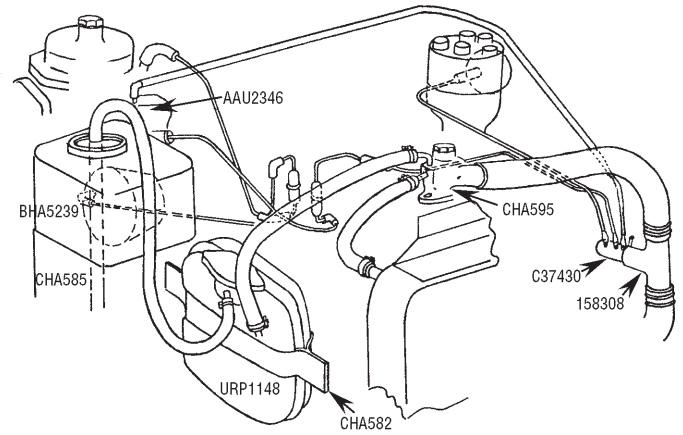
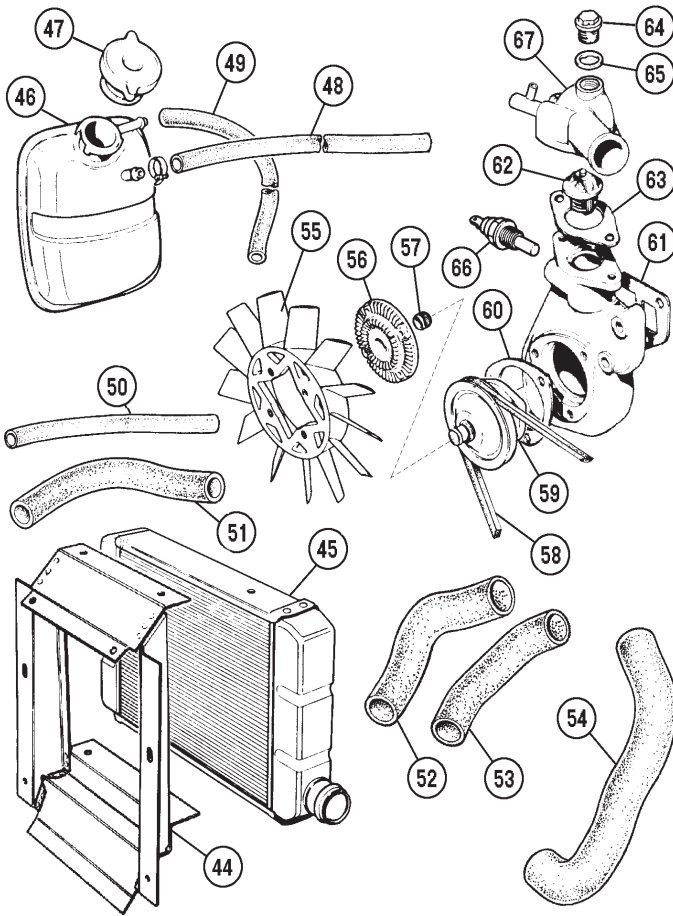

1975 Cooling System Modifications

The following is an extract from the Austin/ MG Technical Service Bulletin 75-A-6 dated August, 1975. **None of the specified parts are currently available.**

Where instance of severe overheating occurs on 1975 MG Midgets, the following modifications should be carried out.

1. Remove and discard the front number plate bracket and plinth assembly. Relocate and mount the front number plate to the center of the bumper, using self-tapping screws.
2. Reposition both horn assemblies by simply bending the mounting bracket upwards and through 90 degrees.
3. Install thermo-vac switch, Part No. C-37430 with 'T' sleeve adaptor, Part no. 158308 in the top radiator hose as shown.

NOTE:- (Remove approximately 1 1/4" from the existing hose to accommodate the 'T' sleeve.)

4. Remove the decell valve from the carburettor and replace with externally vented valve, Part No. AAU-2346.
5. Remove and discard the existing expansion tank and replace with metal type, Part No. URP-1148, using the existing bolts and spacers and new brackets supplied, Part No. CHA-582.

NOTE:- The pressure cap supplied with the metal tank has a double seal, and therefore is not interchangeable with the original cap which should be discarded.

6. Install bracket, Part No. CHA-585 and no-loss bottle, Part No. BHA-5239, utilizing the right-hand upper shock absorber support plate bolts.
7. Remove and discard the thermostat housing and install modified housing, Part No. CHA-595.

NOTE:- The pressure cap supplied with the metal tank has a double seal, and therefore is not interchangeable with the original cap which should be discarded.

8. Connect the vacuum and water hoses as shown in overall illustration.
9. Pressure test system for any leaks.
10. Replace temperature gauge assembly, Part No. AAU-2641.

NOTE:- There are many reasons why an engine will overheat, consequently it is essential to establish that no other problem exists, such as cylinder head gaskets, loose cylinder head bolts, incorrect ignition timing or maladjusted fan belt, etc., prior to carrying out the foregoing modifications.

No.	Part No.	Price (each)	Description	Application	Qty. Req.
-----	----------	--------------	-------------	-------------	-----------

Cross-Flow System - 1500

44	459-775	\$123.95	COWL, radiator		1
45	459-740	\$179.95	RADIATOR	to (c)166303 (1975)	1
	459-745	NA	RADIATOR	from (c)166304 ('76 - on)	1
46	459-750*	\$57.95	EXPANSION TANK	to (c)166303 (1975*)	1
	459-755	NA	EXPANSION TANK	from (c)166304 ('76 - on)	1
47	459-695	\$5.70	CAP, expansion tank		1
48	470-305*	\$5.75	TUBE, to expansion tank	to (c)166303 (1975*)	1
	470-345	\$3.25	TUBE, to expansion tank	from (c)166304 ('76 - on)	1
49	470-340	\$4.55	TUBE, exp. tank to spill tank		1
50	470-345*	\$3.25	TUBE, thermo. hsg. to radiator	to (c)166303 (1975*)	1
51	470-405	\$6.25	HOSE, thermo. hsg. to radiator	from (c)166304 ('76 - on)	1
52	470-410*	\$7.95	HOSE, radiator to pump	to (c)166303 (1975*)	1
53	470-420	\$7.30	HOSE, radiator to pump	from (c)166304 ('76 - on)	1
54	470-415	\$7.95	HOSE, L/H, to thermo. hsg.		1
55	434-570	NA	FAN		1
56	434-575	\$134.95	FAN CLUTCH		1
57	071-239	\$7.95	TOLERANCE RING		1
58	434-590	\$7.30	FAN BELT		1
59	835-655	\$58.95	WATER PUMP		1
60	697-085	\$0.95	GASKET, water pump to housing		1
61	292-040	\$2.10	GASKET, housing to block		1
62	434-180	\$4.95	THERMOSTAT, 160°		1
	434-189	\$4.95	THERMOSTAT, 180°		1
63	292-100	\$0.75	GASKET, thermostat housing		1
64	328-480	NA	PLUG, thermostat housing	original type	1
	459-760	\$6.50	PLUG, thermostat housing	brass replacement	1
65	328-485	\$1.05	WASHER for plug		1
66	071-241	\$9.60	TEMPERATURE SENDER	from (c)200001-on	1
67	363-370*	NA	THERMOSTAT HOUSING	to (c)166303 (1975*)	1

*Note: Parts marked * for 1975 are for unmodified cars only. 1975 Midgets were subject to a warranty modification to the cooling system which involved changing the thermostat housing, expansion tank, hoses, and inserting a T-fitting in the large hose from the radiator to the thermostat housing to allow fitment of a thermo- vac switch. Therefore, details above for 1975 will not match all 1975 cars. **Parts for the modification are not available.**

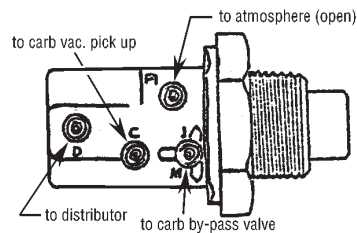

Thermostatic Vacuum Switch



Hayden Electric Fan

Easy to install, these fans may be set up to run in either "pusher" (in front of the radiator) or "puller" (behind the radiator) configuration. The preset temperature control will turn the fan on at 185°F and off at 170°F.

231-678 10" Cooling Fan Kit \$129.95

Heaters

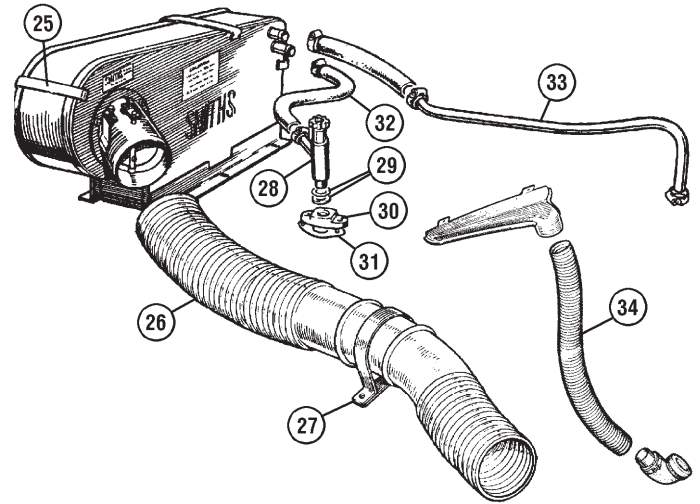
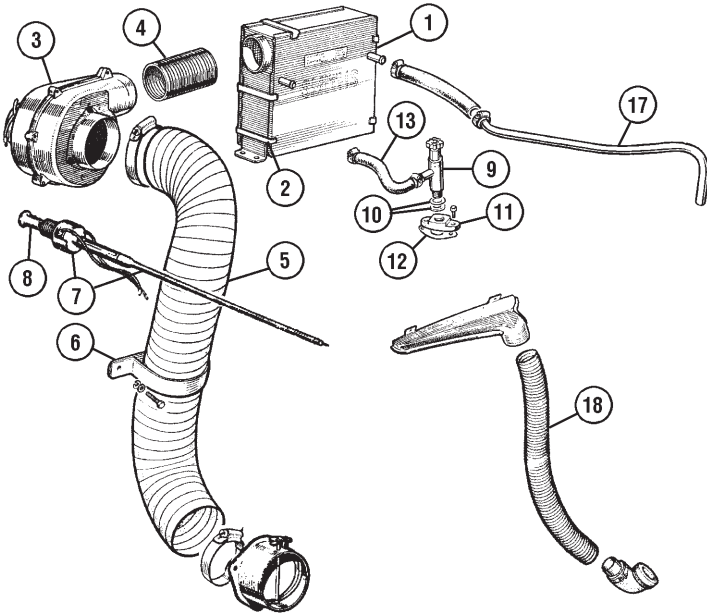

No.	Part No.	Price (each)	Description	Application	Qty. Req.
-----	----------	--------------	-------------	-------------	-----------

948 - 1275 thru 1970 model year

1	362-915	\$265.95	HEATER ASSEMBLY	} all through Sept., 1970	1
	360-675	\$76.95	RADIATOR, heater		A/R
2	363-025	\$1.95	CLIP, heater box		
3	362-905	\$261.95	BLOWER ASSEMBLY	thru 1967	1
	362-925	\$288.95	BLOWER ASSEMBLY	1968-'69	1
4	363-390	\$4.95	AIR DUCT, fan to heater		1
5	456-130	\$28.95	AIR DUCT, replacement type		1
6	326-220	\$6.85	CLAMP		1
7	331-690	NA	HEATER CONTROL, w/switch	Bugeye	1
	331-695	NA	HEATER CONTROL, w/switch	non-Bugeye thru 1966	1
	331-705	NA	HEATER CONTROL, w/switch	1967	1
	473-070	\$1.95	CABLE STOP		1
8	331-085	\$9.95	KNOB, heater control		1
9	360-400	\$29.95	HEATER VALVE		1
10	324-065	\$0.95	WASHER (may use more than one to align heater valve)		A/R
11	360-415	\$4.95	BASE, heater valve		1
12	296-455	\$0.75	GASKET, heater valve		1
13	363-320	\$6.95	HOSE, heater valve		1
17	635-065	\$18.95	PIPE, heater return		1
18	363-180	\$6.95	HOSE, demister		A/R

The "water faucet" heater valve is one of the charming anachronisms that makes a Spridget a Spridget. It's not so charming when it leaks. Part of your regular service routine should include tightening the mounting nuts. If the tap is leaking between the body and the mounting flange, a turn on the tap body should fix it. If not, replacement of the flange and washer will cure the annoyance for good.

No.	Part No.	Price (each)	Description	Application	Qty. Req.
-----	----------	--------------	-------------	-------------	-----------

1275, 1971-'74

25	363-380	NA	CLIP, heater box		A/R
26	456-130	\$28.95	AIR DUCT, replacement type		1
27	326-220	\$6.85	CLAMP		1
28	360-400	\$29.95	HEATER VALVE		1
29	324-065	\$0.95	WASHER		A/R
30	360-415	\$4.95	BASE, heater valve		1
31	296-455	\$0.75	GASKET, heater valve		1
32	363-330	\$7.00	HOSE, heater valve		1
33	635-065	\$18.95	PIPE, heater return		1
34	363-180	\$6.95	HOSE, demister		A/R

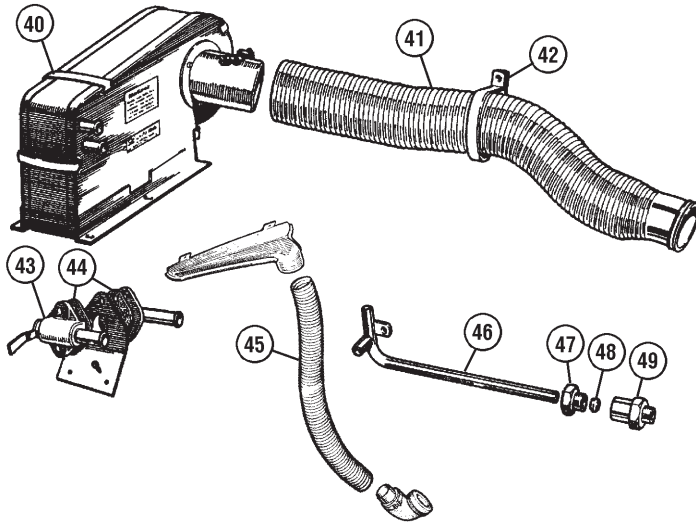

No.	Part No.	Price (each)	Description	Application	Qty. Req.
1500					
40	363-380	NA	CLIP, heater box		A/R
41	363-310	\$29.95	AIR DUCT (replacement type without reduced end)		1
42	326-220	\$6.85	CLAMP		1
43	360-425	NA	HEATER VALVE		1
44	697-360	\$1.20	GASKET, heater valve		2
45	363-180	\$6.95	HOSE, demister		A/R
46	635-105	\$57.95	PIPE, heater return (stainless steel)		1
47	635-150	\$2.95	TUBE NUT		1
48	635-160	\$2.10	COMPRESSION FITTING		1
49	635-170	\$9.25	ADAPTOR		1

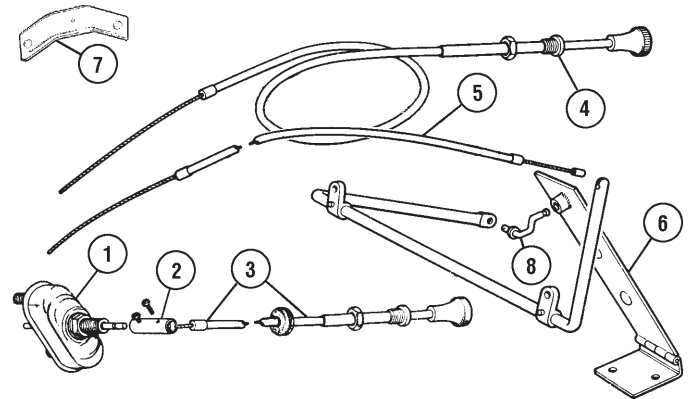

No.	Part No.	Price (each)	Description	Application	Qty. Req.
Engine Controls					
1	145-800	\$38.95	SWITCH	948	1
2	161-500	\$5.45	COUPLING (with screws)	948	1
3	331-630	\$15.95	CABLE, starter pull, orig. type	Bugeye	1
	331-710	\$20.95	CABLE, starter pull, replacement	AH MkII, MG MkI	1
4	331-720	\$14.95	CHOKE CABLE, original type	Bugeye	1
	331-080	\$28.95	CHOKE CABLE, repl. w/plain knob	948, 1098, 1275 (1967)	1
	331-240	\$13.95	CHOKE CABLE, "picture knob"	1275 1968	1
	331-645	\$10.95	CHOKE CABLE, "lettered knob"	1275, 1970-'74	1
	331-490	\$19.95	CHOKE CABLE, "T-handle" replacement for above choke cables		1
	331-650	\$14.95	CHOKE CABLE	1500 w/o auto choke	1
5	331-005	\$7.95	ACCELERATOR CABLE	all except 1500	1
	331-730	\$10.30	ACCELERATOR CABLE	1500 not CA thru (c)188000	1
	331-740	\$12.95	ACCELERATOR CABLE	1500 CA only (c)160160 thru 18800	1
	331-750	\$14.95	ACCELERATOR CABLE	1500 from (c)188001 on	1
6	260-340	\$22.95	ACCELERATOR PEDAL, w/ hinge	all except 1500	1
	260-350	NA	ACCELERATOR PEDAL ASS'Y	1500	1
7	372-295	\$13.95	BRACKET, choke cable	Bugeye	1
8	260-345	\$8.95	LINK, accelerator pedal		1

Exhaust

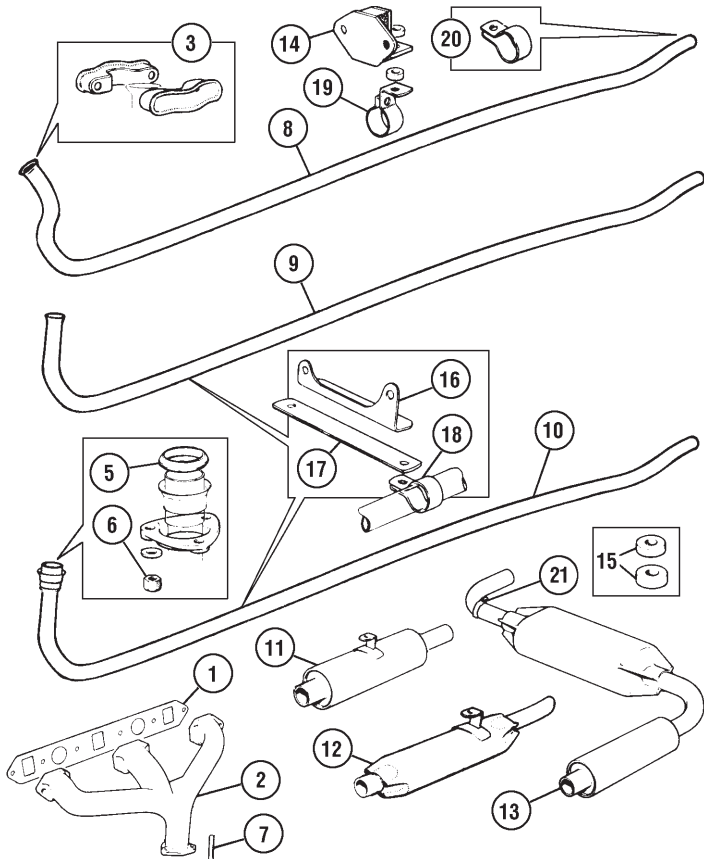

No.	Part No.	Price (each)	Description	Application	Qty. Req.
-----	----------	--------------	-------------	-------------	-----------

948 - 1098 - 1275 Exhaust

1	296-630	\$1.95	GASKET, manifold	all	1
	444-185	\$249.95	MANIFOLD, exhaust	1098, 1275 clamp type	1
2	444-190	NA	MANIFOLD, exhaust	1275 "flange" type	1
3	444-200	\$4.95	CLAMP ASS'Y, headpipe to manifold	948	1
	444-210	\$3.85	CLAMP ASS'Y., headpipe to manifold	1098, 1275 thru '67	1
5	290-510	\$1.95	SEALING RING	} 1275 (1968 - '74)	1
6	311-540	\$0.95	NUT, manifold to pipe		3
7	328-765	\$0.95	STUD, exhaust flange		3
8	444-220*	\$21.95	EXHAUST PIPE, front	948 & 1098 (10CG)	1
9	444-230	\$26.95	EXHAUST PIPE, front	1098 (10CC) & 1275 thru '67	1
10	444-240	\$31.95	EXHAUST PIPE, front	1275 from 1968	1
11	444-250	\$56.95	MUFFLER & TAILPIPE	948 & 1098 (10CG)	1
12	444-260	\$55.95	MUFFLER & TAILPIPE	1098 (10CC) & 1275 thru Sept 73	1
13	444-270	\$86.75	MUFFLER & TAILPIPE	1275 from (c)139773	1
14	614-008	\$3.25	MOUNT, exhaust pipe	} all	1
15	444-280	\$0.95	MOUNTING BUSH, muffler		2
16	444-340	NA	BRACKET	} 1098 (10CC) & 1275	1
17	444-350	\$2.95	STRAP		1
18	444-360	\$3.85	CLAMP, front		1
19	444-390	\$4.15	CLAMP, intermediate	all	1
20	444-365	\$3.65	CLAMP, headpipe to muffler	948	1
	411-090	\$6.75	CLAMP, headpipe to muffler	1098, 1275 thru '67	1
21	444-400	\$5.65	CLAMP, tailpipe	transverse muffler #13	1

* This pipe will be cut for shipping, or be shipped by truck, freight collect.

The exhaust system will last longer and won't rattle when installed with the proper hangers and hardware. The front brackets are especially important to the longevity of the sealing ring. Although not legal in all cases, it is possible to use the single and dual muffler systems interchangeably on 1098/1275 cars.

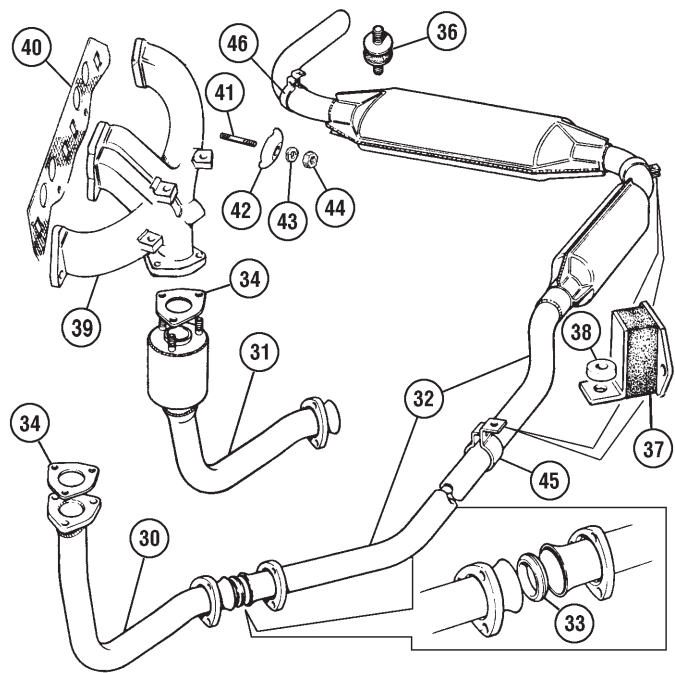

No.	Part No.	Price (each)	Description	Application	Qty. Req.
-----	----------	--------------	-------------	-------------	-----------

1500 Exhaust

30	444-290	\$38.65	FRONT PIPE, w/o converter	{ 1500 to (c)188000 except CA	1
31	444-300	NA	FRONT PIPE, w/ converter N/A - use 444-310 as replacement	{ (c)188001 on Federal CA to (c)212000	1
	444-310	\$344.95	FRONT PIPE, w/ converter	from (c)212001 on CA only	1
32	444-320*	NA	PIPE & MUFFLER ASS'Y, 1-pc.*	1500 to (c)213311	1
	444-330*	NA	PIPE & MUFFLER ASS'Y, 1-pc.*	1500 from (c)213312	1
	444-315	\$109.95	PIPE & MUFFLER ASS'Y, 2-pc.*	all 1500	1
33	444-130	\$2.95	SEALING RING, pipe coupling		1
34	296-690	\$8.70	GASKET, manifold to pipe		1
36	444-080	\$1.95	MOUNT	as fitted	1
37	614-008	\$3.25	MOUNT		2
38	444-090	\$1.95	INSULATING WASHER	(ft. uses 1, intermed. uses 2)	3
39	444-375	\$249.95	MANIFOLD, exhaust	1975-76	1
	444-380	\$329.95	MANIFOLD, exhaust	1977-80	1
40	694-120	\$6.25	GASKET, manifold		1
41	328-650	\$1.95	STUD, manifold to head		6
42	812-025	NA	CLAMP, manifold, long		2
	812-010	\$6.00	CLAMP, manifold, short		4
43	365-730	\$0.20	LOCKWASHER		6
44	310-260	\$0.55	NUT		6
45	444-390	\$4.15	CLAMP, intermediate pipe		1
46	444-400	\$5.65	CLAMP, tailpipe		1

* 1-piece pipe & muffler assemblies must be cut for shipping, or be shipped by truck, freight collect. Your local welding shop can rejoin these pieces. The 2-piece assembly slips together.

Identifying the BMC Engine

The BMC "A" series engine is, like its larger brother, the "B" series fitted to the MGA and MGB, of venerable lineage. Adapted from the Austin A35 it appeared in the Austin-Healey Sprite as the "948", then went through minor revisions as the "1098". A major revision, the "1275", the strongest engine of the series, appeared in late 1966. The "A" series engines have served as the basis for hundreds of modified street Spridgets and full-bore racers.

A "950" was cast in the left side of the "948" block. The "1100" (1098) and "1275" had metal tags riveted to the left side of the block just behind the bearer plate. All of these engines had an aluminum tag riveted to the top of the block on the right front. The first number designates the series: 9 = 948cc; 10 = 1098cc; 12 = 1275cc. If the tags have been removed, measuring the piston bore and main cap journals will reveal its origination. The "948" came with a stamped steel backplate and the 1275 is easily identified by its lack of tappet covers.

948	9C, 9CG
1098	10CG 1 7/8" main bearings 10CC 2" main bearings
1275	12CC, 12CD, 12CE, 12CF, 12CG 12CH, 12CJ, 12CK, 12V

moss

MOSS MOTORS, LTD. TOLL-FREE ORDERS 1-800-667-7872

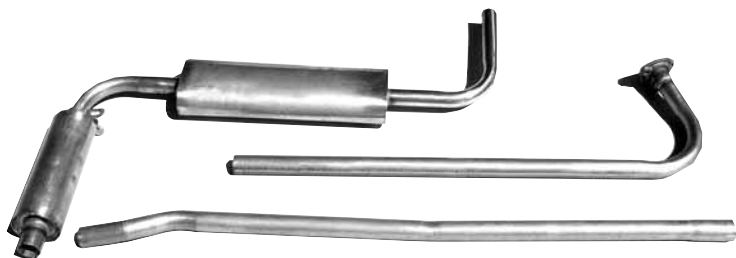

Late 1275 system illustrated.

Stainless Steel Exhaust System

Guaranteed to be the last exhaust system you'll need for your car. Constructed entirely of top quality stainless steel with proper fit and great sound. Includes everything you need from the manifold flange back except clamps and hangers. Guaranteed for life against corrosion.

Sprite/Midget 948, 1098 CG	452-000	\$205.95
Sprite/Midget 1098 CC	452-010	\$205.95
Sprite/Midget early 1275 (approx. '67 w/flared/clamped headpipe)	452-010	\$205.95
Sprite/Midget mid 1275 ('68-'73 w/flanged headpipe & straight muffler)	452-015	\$205.95
Midget late 1275 ('74 w/flanged headpipe & transverse muffler)	452-025	\$285.95
Midget 1500	452-030	\$292.95

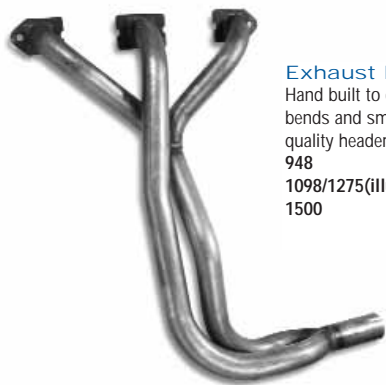

Exhaust Headers

Hand built to obtain maximum power, full bore bends and smooth pipe junctions mark these quality headers.

948	452-060	\$295.95
1098/1275(illus.)	452-065	\$328.95
1500	452-070	\$340.95



Muffler & Tailpipe Sealer

A "must have" to make a positive seal on exhaust pipe slip-joints, this sealer is also useful for temporary exhaust system leak repair. **221-545 \$2.95**

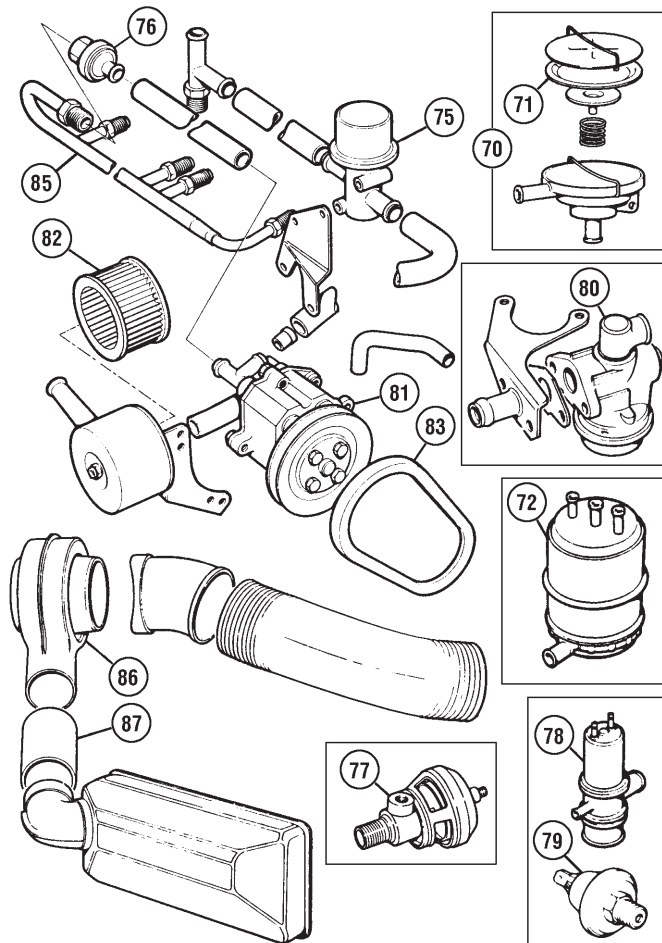

No.	Part No.	Price (each)	Description	Application	Qty. Req.
-----	----------	--------------	-------------	-------------	-----------

Emission Control

70	360-630	\$54.95	P.C.V. VALVE	} 1098 & 1275	1
71	360-635	\$6.95	DIAPHRAGM		1
72	367-100	\$109.95	CANNISTER, vapor adsorption	} 1970 on	1
	367-105	NA	CAP (see note below)		1

Note: Adsorption cannisters from (c)74886 thru 105500 had only 2 hose connections on top. These cannisters are no longer available, and have been superseded by the later 3-connector cannister which we supply. For cars requiring 2-connector cannisters, use cannister #367-100 with cap #367-105 to seal the connector not used. (Either outer connector may be used.)

75	366-010	\$49.95	GULP VALVE	1275	1
76	379-470	\$108.95	CHECK VALVE, orig. mfr.	} 1275 & 1500	1
	367-000	\$18.95	CHECK VALVE, aftermarket		1
77	379-340	NA	E.G.R. VALVE	1500 thru 1976	1
	379-365	NA	E.G.R. VALVE	1500, 1977 on	1
78	367-110	\$66.95	VALVE, anti-run on	1500	1
79	141-715	\$79.95	SWITCH, oil pressure	1500 Fed, CA thru 1977	1
		NA	SWITCH, oil pressure	1500 CA from 1978 on	1
80	379-610	NA	DIVERTER VALVE	1500 thru 1976	1
	379-700	NA	GULP VALVE	1500, 1977-on, CA only	1
81	360-710	NA	AIR PUMP	1275	1
	360-778	\$281.95	AIR PUMP, replacement	1275	1
	379-555	NA	AIR PUMP	1500 thru 1976	1
	379-565	NA	AIR PUMP	1500, 1977 on	1
82	950-230	\$6.70	FILTER ELEMENT, "Crosland"	} 1275 & 1500	1
	950-730	NA	FILTER ELEMENT, various mfr.		1
83	434-580	\$4.15	BELT, air pump	1275	1
	379-620	\$4.15	BELT, air pump	1500	1
85	379-630	NA	AIR MANIFOLD	1275	1
	379-640	NA	AIR MANIFOLD	1500, '75 - '76	1
	379-645	NA	AIR INJECTION PIPE	1500, '77 - '80	1

86	373-920	\$43.95	TEMP. COMPENSATOR	} 1500	1
87	379-660	NA	CONNECTOR		1

LOCAL & OVERSEAS: 805-681-3400

FAX: 805-692-2525 www.mossmotors.com



Carburetors - Bugeye

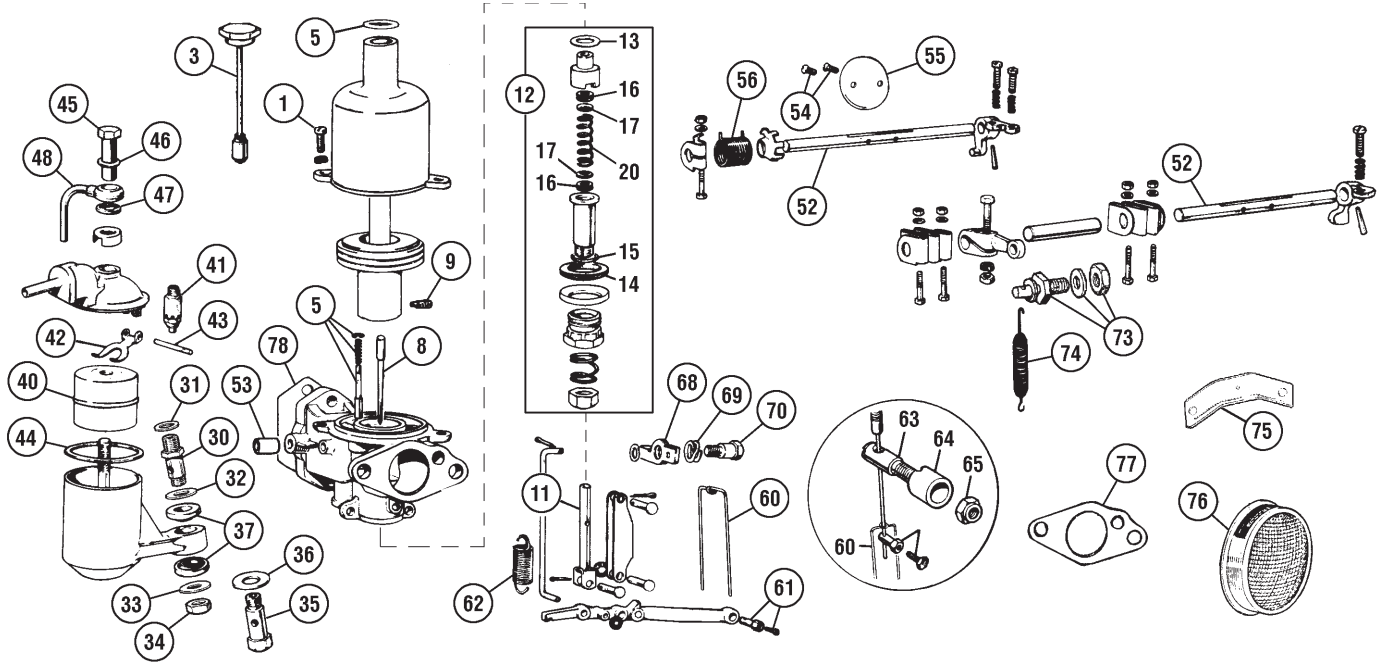

SU H-1 (1 1/8") "Bugeye" only (AUC863)

No.	Part No.	Price (each)	Description	Application	Qty. Req.
	375-460	\$127.95	REBUILD KIT , includes all items marked*, for 2 carburetors		1
	375-465*	\$26.95	GASKET KIT for 2 carburetors		1
1	370-290	\$0.90	SCREW, chamber, 2 per carb.		4
3	370-765	\$30.95	CAP & DAMPER, brass		2
	370-750	\$16.95	CAP & DAMPER, plastic replacement		2
4	370-650*	\$0.95	WASHER		2
5	375-048	\$6.60	PIN & SPRING ASS'Y.		2
8	374-095*	\$9.55	JET NEEDLE, standard (GG)		2
	374-055	\$9.55	JET NEEDLE, rich (EB)		2
	374-145	\$10.70	JET NEEDLE, lean (MOW)		2
9	370-100	\$0.85	SCREW, needle locking		2
11	370-760*	\$11.95	JET, .090"		2
12	370-395	\$32.90	JET BEARING KIT		2
13	370-250*	\$0.95	WASHER, jet bearing		2
14	295-000*	\$1.85	SEAL, cork		2
15	370-410*	\$0.95	WASHER, bottom jet bearing		2
16	295-200*	\$0.95	JET SEAL, cork		4
	365-420	\$0.75	O-RING, leak-free repl. for 295-200 (not in jet bearing kit)		4
17	370-230*	\$1.20	WASHER, cupped		4
20	370-070	\$3.65	SPRING, jet seal		2
30	372-190	\$9.30	STUD, float bowl to carb.	} alternative to #35 & 36	2
31	372-180	\$0.80	WASHER, fiber		2
32	372-200	\$0.95	WASHER, steel, flat		2
33	372-210	\$1.25	WASHER, steel, flat		2
34	311-230	\$0.65	NUT		2
35	370-080	\$8.65	BOLT, float bowl to carb.	} alternative to #30-34	2
36	370-030	\$1.05	WASHER, steel, flat		2
37	370-020*	\$2.95	WASHER, rubber, float bowl mount		4
40	378-050	\$19.95	FLOAT		2
41	373-625*	\$14.35	NEEDLE & SEAT		2
	386-390	\$7.65	GROSE JET, superior replacement for original style needle & seat.		2
42	378-130	\$8.85	LEVER, original cover		2
43	370-060*	\$0.95	PIN, lever		2
44	378-110*	\$0.50	GASKET, float bowl cover		2
45	370-150	\$4.95	BOLT, float bowl cover		2
46	370-130*	\$0.80	WASHER, aluminum		2
47	370-160*	\$0.75	WASHER, fiber		2
48	451-250	\$15.95	OVERFLOW PIPE		2
52	376-005	\$16.95	THROTTLE SHAFT, standard		2
	376-015	\$16.95	THROTTLE SHAFT, oversize diameter		2
53	330-490	\$3.95	BUSH, throttle shaft		4
54	370-090	\$0.65	SCREW, throttle disc		4
55	378-160	\$16.95	THROTTLE DISC		2

No.	Part No.	Price (each)	Description	Application	Qty. Req.
56	370-610	\$5.65	SPRING, front throttle shaft		1
60	378-010	\$9.50	STIRRUP		1
61	378-648	\$8.95	PIN ASS'Y., jet lever to stirrup		2
62	370-550	\$3.55	SPRING, choke return		2
63	378-570	\$21.95	PIN, choke control		1
64	378-575	\$16.95	COLLAR, choke control pin		1
65	311-610	\$0.90	NUT		1
66	378-648	\$8.95	CABLE STOP		1
68	378-230	NA	LEVER, fast idle		1
69	370-460	\$1.10	SPRING WASHER		1
70	370-450	\$6.35	BOLT, shouldered		1
73	375-108	\$2.45	PIN ASS'Y., throttle spring		1
74	370-335	\$1.95	SPRING, throttle		2
75	372-295	\$13.95	BRACKET, choke cable		1
76	373-420	\$38.95	AIR FILTER, front, repro. of original		1
	373-425	\$38.95	AIR FILTER, rear, repro. of original		1
77	295-010*	\$0.95	GASKET, filter to carb.		2
78	295-015*	\$1.10	GASKET, carb. to manifold (gasket set includes 2)		6

SU Tool Kit

An assortment of handy tools for the home mechanic. Instructions included. Suitable for all cars with SU carbs.

386-300 \$23.95

Carburetor Synchronizer

Used to synchronize airflow between multiple carbs, this is an indispensable tool for the serious home mechanic.

386-200 \$32.95

SU Jet Wrench

Mixture adjustments on SU carbs (except HIF type) are much easier with the proper tool. 5/16 Whitworth size for original carbs. & replacement H-type, 17mm for new replacement HS type carbs.

386-400 Jet Wrench, 5/16 W \$2.95

386-401 Jet Wrench, 17mm \$8.15

SU Jet Centering Tool

Jet centering is critical on older fixed needle SU carbs. This simple tool makes it a snap.

386-500 \$21.95



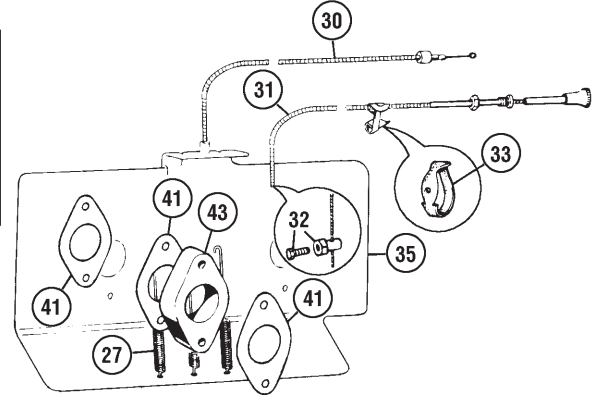
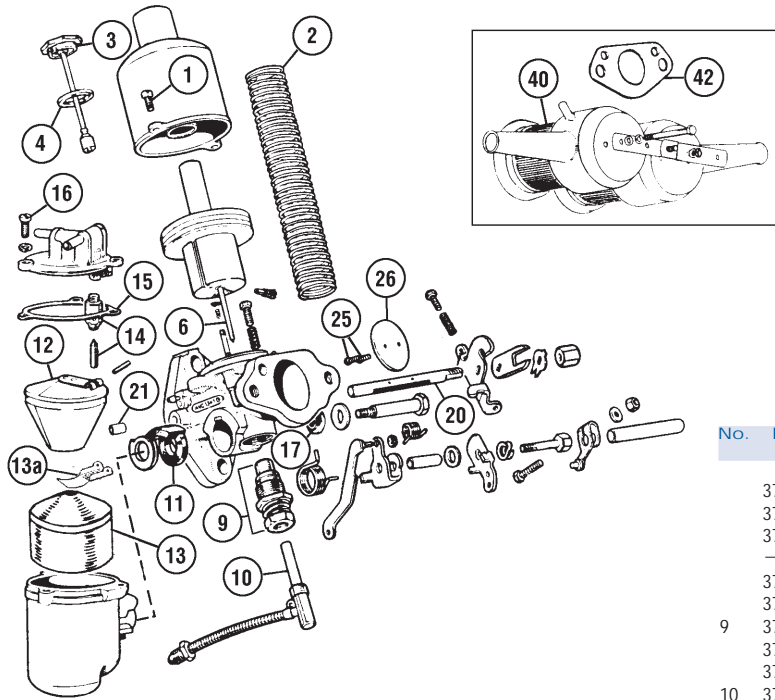

SU HS-2 (1 1/4")

No.	Part No.	Price (each)	Description	Application	Qty. Req.
-----	----------	--------------	-------------	-------------	-----------

New SU Carburetor Sets

Carburetor #	Application	Qty.
370-708	948 Sprite MkII, Midget MkI	1
370-718	1098, 1963 - '66	1
370-728	1275, 1967†	1
370-908	1275, 1968 - '69†	1
370-928	1275, 1969 - '71†	1
370-938	1275, early 1972†	1
370-948	1275, 1972 - '74†	1

† Years given are approximate model year dates.

375-538†	\$127.95	MASTER REBUILD KIT , for 2 carbs 948 thru 1275 (not Bugeye)	1
*Master Rebuild Kit† is a genuine S.U. kit. Includes all parts marked †. Jet needles not included.			
375-450*	\$125.95	REBUILD KIT, for 2 carbs. 948, except Bugeye	1
375-410*	\$135.95	REBUILD KIT, for 2 carbs. 1098, 1275 AUD136 & 266	1
375-420*	\$147.95	REBUILD KIT, for 2 carbs. 1275 AUD328 & 404	1
375-430*	\$140.95	REBUILD KIT, for 2 carbs. 1275 AUD502 & 549	1
* Rebuild kits include items marked *.			
375-435*†	\$12.65	GASKET KIT, for 2 carbs.	1
1	370-290	\$0.90 SCREW, chamber to body, 2 per carb.	4
2	370-530	\$5.90 SPRING, piston return	2
3	370-750	\$16.95 CAP & DAMPER, plastic cap	2
4	370-650*†	\$0.95 WASHER	2

6	374-125	\$11.95	JET NEEDLE, lean (GX)	} 948 AUD990	2
	374-305*	\$13.95	JET NEEDLE, standard (V3)		2
	374-295	\$10.70	JET NEEDLE, rich (V2)		2

	374-095	\$9.55	JET NEEDLE, lean (GG)	} 1098/1275 AUD136/266 2	2
	374-005*	\$12.95	JET NEEDLE, standard (AN)		2
	374-135	\$11.95	JET NEEDLE, rich (H6)		2
9	374-355*	\$11.95	JET NEEDLE, spring-loaded (AAC)	1275 AUD328 & 404	2
	374-365*	\$12.95	JET NEEDLE, spring-loaded (ABC)	1275 AUD502 & 549	2
	372-265	\$32.90	JET BEARING KIT	AUC990, AUD136	2
	372-275	\$25.65	JET BEARING KIT	AUD266	2
	372-285	\$25.65	JET BEARING KIT	AUD328,404,502,549	2
10	378-430*†	\$20.95	JET, front		1
	378-440*†	\$20.95	JET, rear		1
11	378-095*	\$12.30	ADAPTOR, front	} AUC990, 948 engine	1
	378-085*	\$8.95	ADAPTOR, rear		1
	378-090*	\$8.95	ADAPTOR, front	} 1098 & 1275 engines	1
	378-085*	\$8.95	ADAPTOR, rear		1
12	378-470	\$14.35	FLOAT, replacement, may need shims under needle seat.		2
13	378-380	\$12.95	FLOAT, brass	} AUC990	2
13a	370-155	NA	LEVER for float #13		2
14	373-625**†	\$14.35	NEEDLE & SEAT		2
	386-390	\$7.65	GROSE JET, superior replacement for orig. style needle & seat.		2
15	378-360*†	\$0.85	GASKET, float chamber		2
16	370-290	\$0.90	SCREW, 3 per carburetor		6
17	378-070*	\$1.65	WASHER, rubber		2
20	378-370†	\$13.95	THROTTLE SHAFT		2
	378-375	\$16.95	THROTTLE SHAFT, oversize		2
21	330-490†	\$3.95	BUSH, throttle shaft		4
25	370-090†	\$0.65	SCREW, throttle disc		4
26	370-280†	\$11.95	THROTTLE DISC		2
27	370-335	\$1.95	SPRING, choke return		2
	370-320	\$1.95	SPRING, throttle return		1
30	331-005	\$7.95	ACCELERATOR CABLE		1
31	331-080	\$28.95	CHOKE CABLE, repl., plain knob	948 & 1098, 1275 (1967)	1
	331-240	\$13.95	CHOKE CABLE, "picture knob"	1275, 1968	1
	331-645	\$10.95	CHOKE CABLE, "picture knob"	1275, 1970 - '74	1
	331-490	\$19.95	CHOKE CABLE, "T-handle", replacement for both of the above cables		1
32	375-128	\$3.10	CABLE STOP, choke cable		1
33	161-850	\$1.95	STRAP, choke cable to heater clip		1
35	372-430	\$25.95	HEAT SHIELD	1098 & 1275	1
40	950-260	\$14.75	AIR FILTER ELEMENT, "Crosland" brand		2
	373-435	\$40.95	AIR FILTER ELEMENT, "K&N" brand		2
	950-760	\$11.95	AIR FILTER ELEMENT, various manufacturers		2
41	294-500*†	\$0.95	GASKET, carburetor to manifold		6
42	295-020*†	\$0.95	GASKET, air cleaner to carb.		2
43	372-375	\$24.65	SPACER		2



SU Carb Rebuild Video

Anyone can tune or rebuild SU carbs with the help of our 2 hour and 40 minute video. This easy to follow video uses a combination of sights, sounds and simple conversational dialog to unravel the mysterious SU. A must for home mechanics.

211-035 \$39.95



Carburetor Dashpot Oil

Finally take all the guesswork out of what type of oil to use in your dashpots. Specially formulated for all SU and Zenith-Stromberg carburetors, this oil ensures the correct piston movement so critical for correct fuel mixture and optimum performance. You don't have to use engine oil any more. 125ml. supply should last a long time.

220-225 \$8.95

LOCAL & OVERSEAS: 805-681-3400

FAX: 805-692-2525

www.mossmotors.com

MOSS

Carburetor - Midget 1500

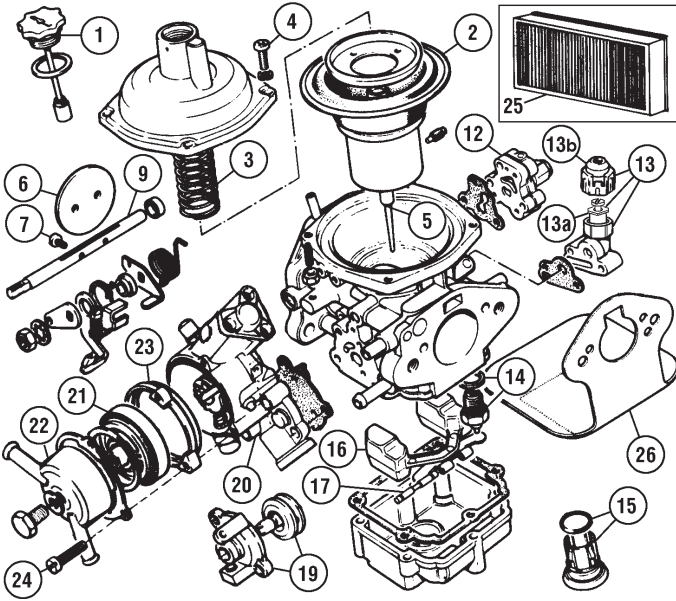

Zenith-Stromberg 150-CD4T

No.	Part No.	Price (each)	Description	Application	Qty. Req.
	366-730	NA	CARBURETOR, C3754	Federal, 1975 - '76	1
	366-735	NA	CARBURETOR, C3838	Federal, 1977	1
	366-740	NA	CARBURETOR, C3962	Federal, 1978 on	1
	366-745	NA	CARBURETOR, C3755	California, 1975 - '76	1
	366-750	NA	CARBURETOR, C3863	California, 1977	1
	366-755	NA	CARBURETOR, C3963	California, 1978 on	1
	375-440	\$32.90	REBUILD KIT , includes all items marked * plus all seals and gaskets. Does not include metering needle.		1
	375-445	NA	GASKET KIT		1
	295-025	NA	GASKET, carb. to manifold		1
	295-030*	\$0.80	GASKET, air cleaner to carb.		1
1	366-660	\$25.70	CAP & DAMPER	C3754, 3838, 3755, & 3863	1
	366-665	\$26.70	CAP & DAMPER	C3962 & C3963	1
2	366-670*	\$6.60	DIAPHRAGM		1
3	366-675	\$8.35	SPRING, air piston		1
4	365-380	\$0.90	SCREW, cover to body		4
5	374-405	NA	METERING NEEDLE (44A) non-adjustable	C3754 & C3755,	1
	374-415	\$31.95	METERING NEEDLE (44A)	C3838, adjustable	1
	374-425	\$24.95	METERING NEEDLE (450)	C3962	1
	374-435	\$55.55	METERING NEEDLE (45K)	C3863	1
	374-440	\$30.80	METERING NEEDLE (45R)	C3963	1
6	366-680	\$11.95	THROTTLE DISC		1
7	366-685	\$0.85	SCREW, disc to shaft		2
9	366-690	\$16.40	THROTTLE SHAFT		1
12	366-695	\$78.15	BYPASS VALVE ASSEMBLY	C3754, 3755, 3863, & 3963	1
	366-700	\$78.15	BYPASS VALVE ASSEMBLY	C3838 & C3962	1
	365-745	\$9.95	DIAPHRAGM KIT, bypass valve		1
13	366-165	\$42.20	REGULATOR, idle air		1
13a	366-215	\$13.35	ADJUSTER, nylon		1
13b	366-245	\$8.25	COVER		1
14	366-705*	\$14.95	NEEDLE & SEAT ASSEMBLY		1
	386-350	\$7.65	GROSE JET, superior replacement for original style needle & seat.		1
15	366-070	\$10.65	PLUG & O-RING, float chamber		1
	365-470*	\$0.60	O-RING, float chamber plug		1
16	365-505	\$24.95	FLOAT ASSEMBLY		1
17	366-080	\$4.95	PIN, float pivot		1
19	366-710	\$105.95	STARTER BOX	C3754	1
20	366-715	\$191.95	HOUSING ASS'Y., auto choke	} all except C3754	1
21	366-190	\$72.95	HEAT MASS ASS'Y., auto choke		1
22	366-200	\$29.95	COVER, heat mass		1
23	366-180	\$19.55	INSULATOR		1
24	366-175	\$1.20	SCREW, short		1
	366-185	\$1.85	SCREW, long	2	
25	950-210	NA	AIR FILTER ELEMENT, "Crosland" brand		1
	950-710	\$17.95	AIR FILTER ELEMENT, various manufacturers		1
26	375-480	NA	HEAT SHIELD		1



1500 Manual Choke Conversion Kit

Gain all the advantages of manually controlled choke, while leaving your car's original appearance intact by using this easy to install kit. Designed in England by Zenith-Stromberg engineers, this kit includes all necessary mounting hardware and detailed instructions. 386-325 \$124.95

Amendments to the Clean Air Act make it illegal for anyone to change or alter the emission control system of any automobile in the United States except for cars used exclusively for off-road use.



Zenith-Stromberg Mixture Adjustment Tool

An essential item for owners of 1975 or later cars with a single Zenith-Stromberg carburetor. 386-310 \$9.85

Carburetor Dashpot Oil

Finally take all the guesswork out of what type of oil to use in your dashpots. Specially formulated for all SU and Zenith-Stromberg carburetors, this oil ensures the correct piston movement so critical for correct fuel mixture and optimum performance. You don't have to use engine oil any more. 125ml. supply should last a long time. 220-225 \$8.95



moss

MOSS MOTORS, LTD. TOLL-FREE ORDERS 1-800-667-7872

Weber Downdraft Conversions

The ideal road use conversion, this Weber downdraft set-up gives improved full-throttle performance without sacrificing fuel economy or driveability. Simple to install, no modifications are required to your existing linkage. Works with either stock cast iron exhaust manifold or tubular headers. Kit includes Weber carburetor, manifold, air filter and linkage tailored for your car.



Due to the worldwide shortage of Weber carburetors, please call for availability. Prices may fluctuate from those published.



1275 Sprite/Midget	222-275	\$579.95
Midget 1500 (automatic water choke)	222-255	\$579.95
Midget 1500 (automatic electric choke)	222-256	\$579.95
Midget 1500 (manual choke)	222-257	\$579.95
Rebuild Kit (for all of above)	222-266	\$74.95

Weber Sidedraft Carburetor Conversion

For serious performance seekers, the Weber sidedraft conversion has been a popular option since the early '60s. High performance DCOE carburetor, combined with a precision cast alloy manifold will help you extract maximum power from your modified engine. Although installation is straightforward enough, tuning the carburetor to the particular requirements of your engine is best done by a mechanic with experience in tuning Webers. Air filters are sold separately.

Midget 1500 Side-Draft Carburetor, Kit	222-480	\$799.95
Sprite/Midget 948/1098 Side-Draft Carburetor Kit	222-440	\$799.95
Sprite/Midget 1275 Side-Draft Carburetor Kit	222-450	\$799.95
Air Filter	222-240	\$84.95

*Amendments to the Clean Air Act make it illegal for anyone to change or alter the emission control system of any automobile in the United States except cars used exclusively for off-road use.

Amendments to the Clean Air Act make it illegal for anyone to change or alter the emission control system of any automobile in the United States except cars used exclusively for off-road use.

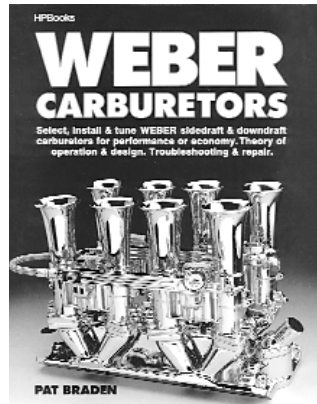

Weber Carburetors

by Pat Braden

Learn how to select and tune weber sidedraft and downdraft carburetors for performance and economy. Also covered in detail is the design and theory of operation, as well as troubleshooting and repair. Softbound, 8" x 10", 300 pages, hundreds of illustrations.

213-430 \$20.95

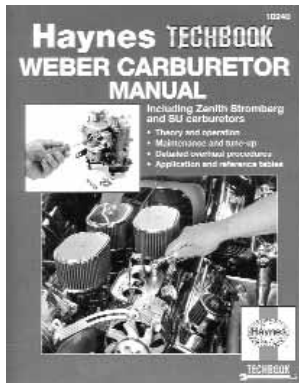

Carburetor Manual

SU, Zenith-Stromberg, and Weber carburetors are all covered in complete detail in this thoroughly illustrated thick paperback.

211-430 \$18.95



SU Tuning Tips & Techniques

by G. R. Wade

If you only buy one book on SU carbs, this is a good one. Combining years of collected wisdom and factory published information, it'll help you solve all the standard SU carb problems.

211-345 \$29.95

Fuel System

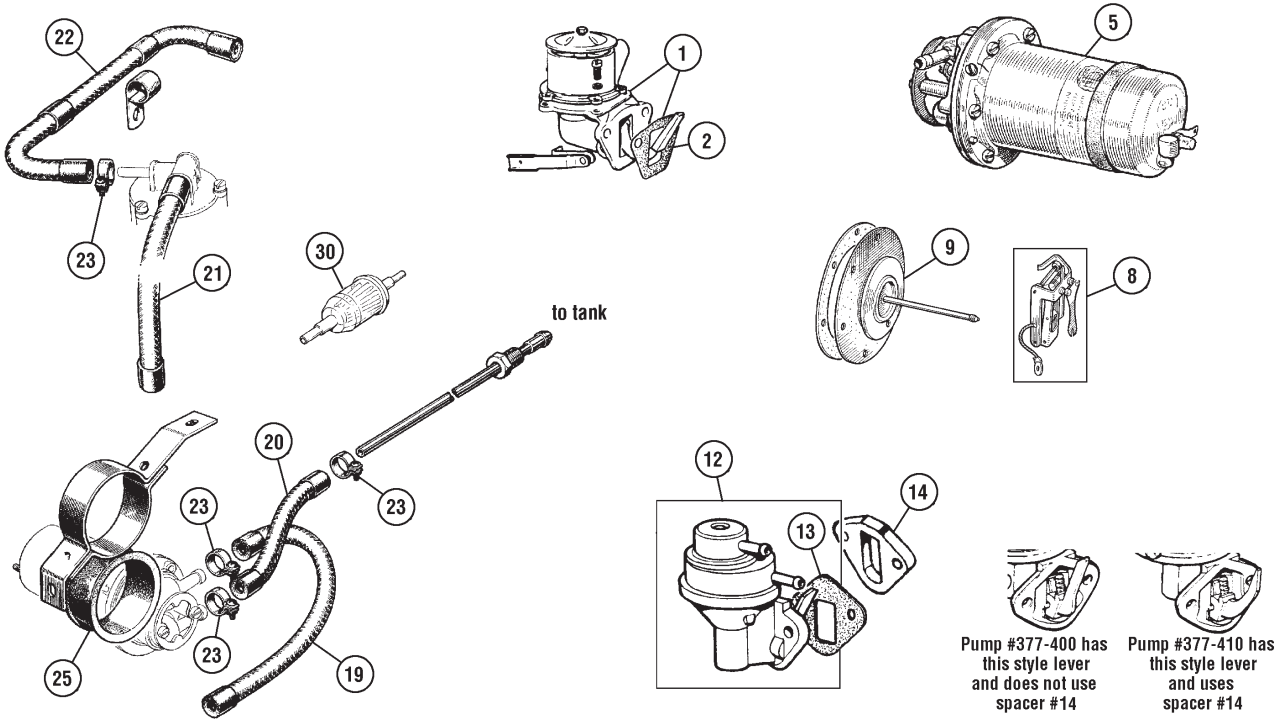

No.	Part No.	Price (each)	Description	Application	Qty. Req.
1	377-390	\$68.95	FUEL PUMP, mechanical	} 948, 1098 (10CG)	1
	377-395	\$123.95	REBUILD KIT, fuel pump		1
2	296-220	\$0.95	GASKET, fuel pump		1
5	377-175	\$107.95	FUEL PUMP, original SU	} 1098 (10CC) & 1275	1
	377-185	\$112.95	FUEL PUMP, replacement		1
8	377-080	\$11.95	POINT SET	} as required	1
9	377-130	\$30.95	DIAPHRAGM, 2 3/8" shaft		1
	377-140	\$28.95	DIAPHRAGM, 2 15/16" shaft		1
12	377-400	\$24.95	FUEL PUMP, mechanical, does not use spacer	} 1500 thru 1977	1
	377-410	\$34.95	FUEL PUMP, mechanical, uses spacer block This pump must be used with the spacer. Since new spacers are not available, you must re-use your old spacer. If you don't have one, use pump 377-400, which does not require the spacer.	} 1500, 1978 on	1
	377-405	NA	REBUILD KIT, fuel pump	} all 1500	1
13	697-125	\$1.20	GASKET		1/2
14	377-415	NA	SPACER	1500, 1978 on	1
19	376-905	NA	FUEL HOSE, pump outlet	Sprite MkII, Midget MkI	1
	376-880	\$6.85	FUEL HOSE, pump outlet, 9 3/4"	} thru 1971	1
	376-915	\$4.60	FUEL HOSE, pump inlet, 6 1/2"		1
	376-885	\$9.95	FUEL HOSE, pipe to carb., 11 1/2"	} 1098 & 1275	1
	376-895	\$7.15	FUEL HOSE, filter to carb., 7 1/2"		1
	376-890	NA	FUEL HOSE, carb. to carb.		1
22	376-890	NA	FUEL HOSE, carb. to carb.		1
23	326-325	\$1.05	CLAMP, fuel lines		A/R
25	377-360	\$4.15	GROMMET, fuel pump mount	1098 & 1275	1
30	377-300	\$3.95	FUEL FILTER (may differ from illus.) (optional)		1

SU Solid State Fuel Pump

Electric fuel pumps with modern reliable solid state switching which eliminates the hassles of breaker points (but retains the traditional ticking sound). Now you can have the vintage appearance with the peace of mind only an electronic fuel pump can offer.



1098-1275 positive ground 377-295 \$148.95
1098-1275 negative ground 377-285 \$148.95

Solid State Electric Fuel Pump

Solid state electronic fuel pumps can be used in conjunction with, or in place of, your original pump. These pumps will push or pull fuel through your original pump, or may be put in-line and used as a backup (when switched separately). May be used on positive and negative ground cars.

377-420 \$99.95

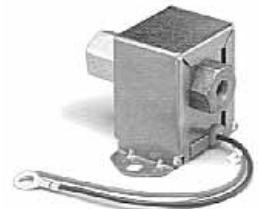

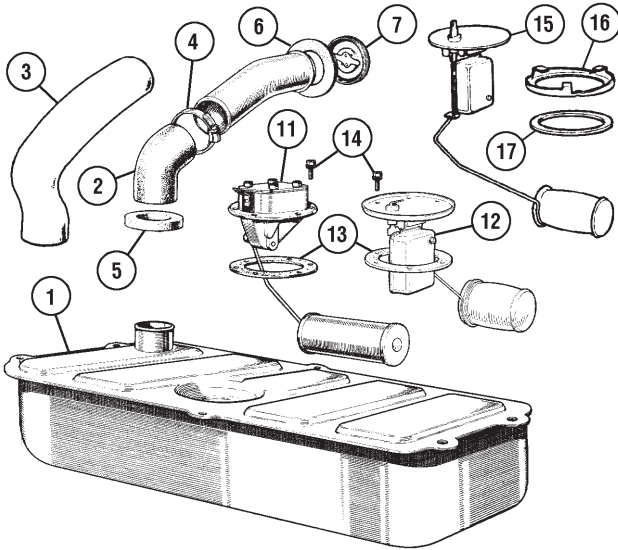

No.	Part No.	Price (each)	Description	Application	Qty. Req.
1	471-190	\$345.95	FUEL TANK	Bugeye	1
	471-230	\$203.95	FUEL TANK	thru 1969	1
	471-240	NA	FUEL TANK, evaporative loss control	1970 - '71	1
	471-250	NA	FUEL TANK	1972 on	1
2	282-945	\$20.95	HOSE, filler to tank	thru 1275 (except Bugeye)	1
	282-920	\$33.95	HOSE, filler to tank (as illus)	1500 (as fitted)	1
3	282-946	\$36.55	HOSE, filler to tank (long S-shaped)	1500 (as fitted)	1
4	326-460	\$2.35	CLAMP, filler hose		2
5	282-930	\$1.65	SEAL, tank to trunk floor		1
6	280-105	\$6.80	GROMMET, filler neck		1
7	202-750	\$11.95	GAS CAP	thru 1969	1
	202-755	\$14.95	GAS CAP	1970 on, except CA 1500	1
	202-765	\$19.95	GAS CAP	CA 1500 (c) 160160 to 166300	1
	202-755	\$14.95	GAS CAP	CA 1500 from (c)166301	1
11	361-880	\$58.95	SENDING UNIT	Bugeye	1
				MG to (c)60459	1
				AH MkII - MkIV (c)72039	1
12	361-890	\$39.95	SENDING UNIT	MG from (c)60460 105500	1
				AH from HAN9-72040 on thru 1971	1
13	293-415	\$0.95	GASKET	} all through 1971	1
14	323-030	\$0.30	SCREW, sending unit to tank		6
15	361-900	\$39.95	SENDING UNIT	} MG 1972 on	1
16	360-665	\$1.45	RING, locking		1
17	293-410	\$0.95	RING, sealing		1

Gas Tank Care

Step 1: Bio-Degradable Cleaner

This is an industrial strength gas tank cleaner that allows you to clean out your car's gas tank yourself. We recommend using this cleaner in conjunction with our etching liquid when planning to seal your tank.

220-620 \$35.45 Cleaner (1 gallon)

Step 2: Fuel Tank Etching Liquid

Use this bio-degradable etcher as a prep for our slushing compound to give maximum adhesion of the sealer. Our cleaner should be used first to remove oil and grime. 16 oz.

220-630 \$16.50 Etching Liquid

Step 3: Tank Slushing Compound

This is what the factory should have used! This amazing fluid puts a protective film on the entire inside surface of your fuel tank to prevent rust. Save yourself from having to buy an expensive fuel tank later on. Tanks should be cleaned with 220-620, then etched with 220-630 first. This compound is formulated to resist the alcohols found in gasoline.

220-450 \$35.95 Slushing Compound



SPRITE-MIDGET



ReLead & Stor-N-Start

Stor-N-Start is a gasoline additive which prevents harmful gum and resin deposits from forming in fuel lines and carburetors. Use one ounce per five gallons of fuel before storing your car, and it will start right up—even after extended periods. ReLead replaces the valve lubricating qualities of lead formerly used in gas. Unless your cylinder head has been converted to run on unleaded, you need ReLead.

220-375 Stor-N-Start \$6.50
220-390 ReLead \$10.95



"Aston" Locking Gas Cap

Clever, quick release gas cap looks like those fitted to many historic sports and race cars. But looks can be deceiving, because under the quick release flip cap is a neat locking gas cap. The caps themselves are theft proof, and they secure your fuel at the same time. Cast aluminum quick release cap is

polished to a high luster, and installation is as easy as installing a regular gas cap. Fits Sprites and Midgets through 1969.

407-125 \$159.95

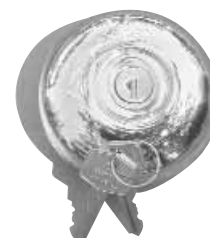

Locking Gas Cap

Our chrome locking fuel filler caps are similar to originals, but with an important extra feature. With fuel prices as high as they are, a locking gas cap is inexpensive insurance against thieves. Supplied complete with two keys. Fits Sprites and Midgets from 1959 through 1969.

202-760 \$20.95

Clutch

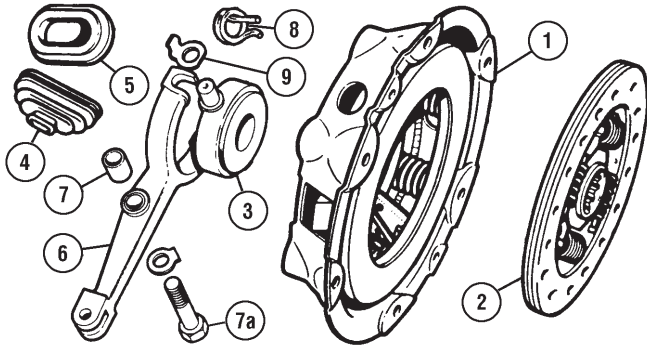

No.	Part No.	Price (each)	Description	Application	Qty. Req.
948 - 1098 - 1275 Clutch					
	190-960	\$299.95	CLUTCH KIT, Borg & Beck	948	1
	190-965	\$209.95	CLUTCH KIT, Quinton-Hazel	948	1
	190-970	\$268.95	CLUTCH KIT, Borg & Beck	1098	1
	190-980	\$187.95	CLUTCH KIT, Borg & Beck	1275	1
	190-985	\$151.95	CLUTCH KIT, Quinton-Hazel	1275	1
1	190-830	\$223.95	PRESSURE PLATE, new	948	1
	190-840	\$167.95	PRESSURE PLATE, new	1098	1
	190-850	\$103.95	PRESSURE PLATE, new	1275	1
2	190-870	\$63.65	CLUTCH DISC, new	948, 6 1/4"	1
	190-880	\$78.95	CLUTCH DISC, new	1098, 7 1/4"	1
	190-890	\$59.95	CLUTCH DISC, new	1275, 6 1/2"	1
3	190-910	\$22.95	RELEASE BEARING	948	1
	190-915	\$22.95	RELEASE BEARING	1098	1
	190-920	\$29.95	RELEASE BEARING, stock type	1275	1
	190-295	\$39.95	RELEASE BEARING, roller bearing type, heavy duty	1275	1
4	461-010	\$4.75	BOOT, clutch lever		1
5	461-870	\$6.65	COVER, dust	948, 1098 & 1275	1
6	190-955	\$94.95	LEVER, clutch release	1098 & 1275	1
7	330-435	\$1.95	BUSH	all	1
7a	330-505	\$4.95	BOLT, clutch release fork	1098 & 1275	1
8	190-310	\$1.95	CLIP, release bearing	948	2
9	190-315	\$1.95	CLIP, release bearing	1098 & 1275	2

NOTE: for early cars with the ribcase gearbox, use the release bearing appropriate for the engine actually used.

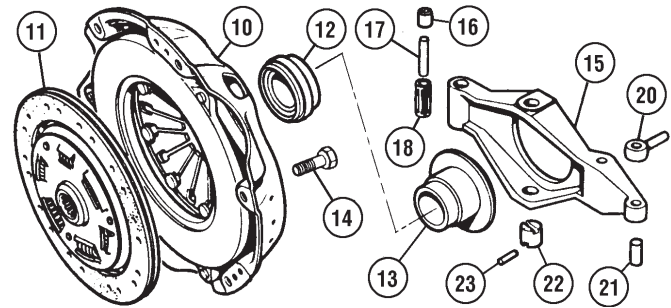

No.	Part No.	Price (each)	Description	Application	Qty. Req.
1500 Clutch					
	190-990	\$175.95	CLUTCH KIT, Borg & Beck		1
	190-995	\$119.95	CLUTCH KIT, Quinton-Hazel		1
10	190-860	\$95.95	PRESSURE PLATE, new		1
11	190-900	\$72.60	CLUTCH DISC, new		1
12	190-925	\$42.95	RELEASE BEARING		1
13	190-945	NA	SLEEVE, release bearing		1
14	322-040	\$0.45	BOLT, clutch to flywheel		6
15	190-950	NA	ARM		1
16	330-445	\$4.60	BUSH, in bell housing		2
17	190-930	\$4.95	RELEASE ARM PIN		1
18	330-455	\$7.20	RELEASE ARM BUSH		1
20	190-935	\$10.95	PUSH ROD		1
21	190-940	\$4.15	PIN, push rod to arm		1
22	328-625	\$4.35	PLUG, sleeve to arm		1
23	329-890	\$0.60	PIN in plug		1



387-320	\$4.95	CLUTCH ALIGNMENT TOOL	948 - 1275	1
387-330	\$4.95	CLUTCH ALIGNMENT TOOL	Midget 1500	1

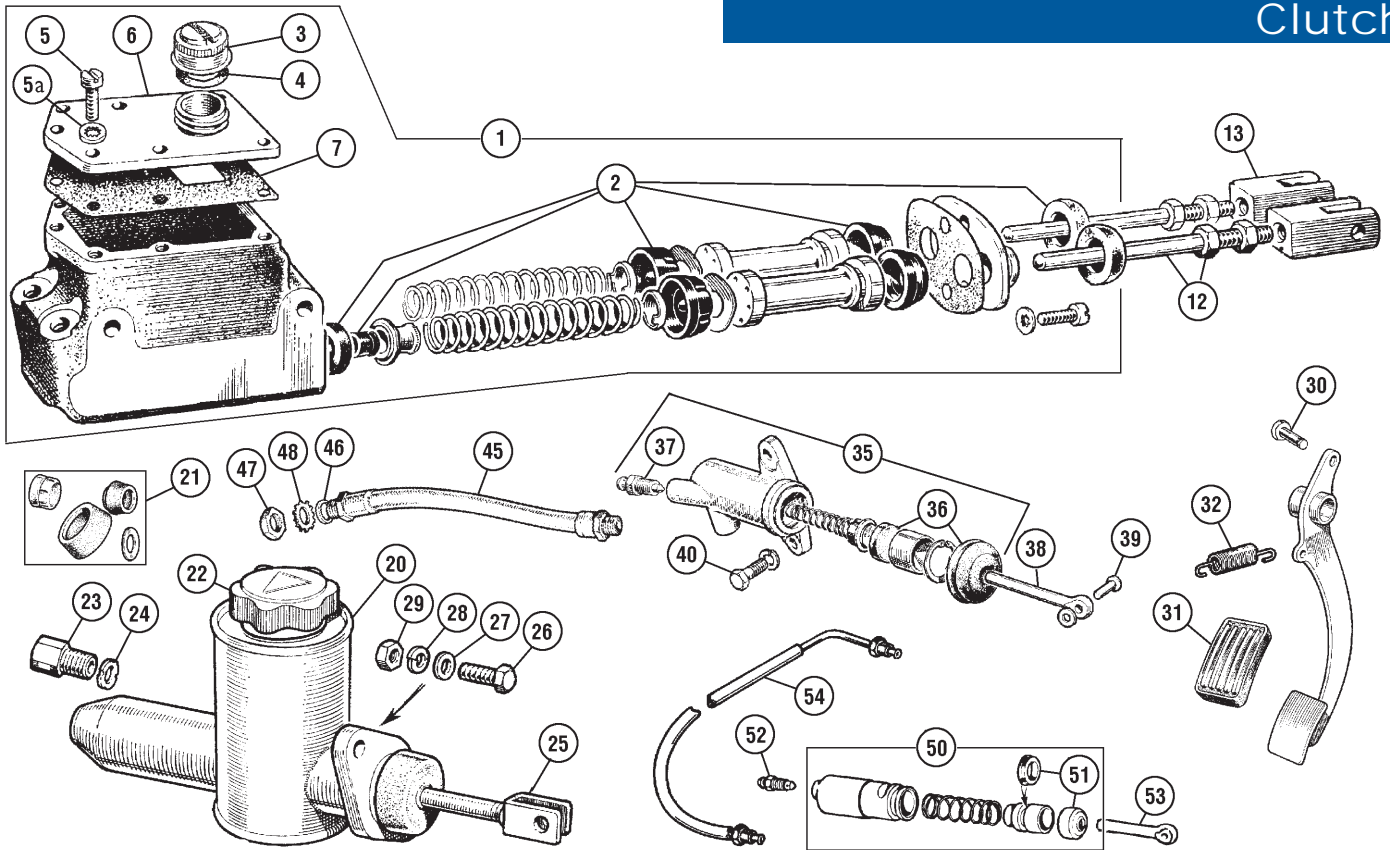

No.	Part No.	Price (each)	Description	Application	Qty. Req.
Clutch Hydraulics					
1	180-670	\$466.95	MASTER CYLINDER, 7/8" bore	948 drum brakes	1
	180-555†	NA	MASTER CYLINDER, 3/4" bore†	1098 front disc brakes	1
2	180-970	\$14.95	REPAIR KIT, clutch & brake*	948	1
	180-565	\$14.95	REPAIR KIT, clutch & brake*	1098	1
† The earlier master cylinder 180-670 may be used as a replacement.					
* These repair kits may include a replacement type brake cylinder check valve, or the rubber cup for the original check valve.					
3	180-210	\$5.95	CAP, plastic replacement	} 948 & 1098	1
4	180-450	\$3.45	WASHER, cap		1
5	323-500	\$1.00	SCREW, front & top covers		9/7
5a	462-385	\$0.40	LOCKWASHER		9/7
6	NA		COVER		1
7	180-270	\$2.95	GASKET		1
8	180-030	\$3.10	SPRING		948
	181-710	\$4.00	SPRING	1098	2
10	180-020	\$1.95	GASKET	} 948 & 1098	1
11	180-010	NA	PLATE		1
12	180-305	\$8.65	PUSH ROD		2
13	180-315	\$10.95	FORK		2
20	180-625	\$82.95	MASTER CYLINDER, Lockheed replacement	} 1275 & 1500	1
21	180-925	\$6.60	REPAIR KIT, cyls. not marked †		1
	180-915	\$7.95	REPAIR KIT, cyls. marked-see illus. showing marks below †		1
			CAP (orig. cyls. only)		1
22	180-210	\$5.95	CAP (orig. cyls. only)		1
23	180-400	\$9.95	ADAPTOR, pipe to master cylinder		1
24	324-730	\$0.40	WASHER, pipe to master cylinder		1
25	180-605	NA	PUSH ROD		1
26	313-000	\$0.30	BOLT, master cylinder mounting		2
27	365-720	\$0.30	WASHER		2
28	365-730	\$0.20	LOCKWASHER	2	
29	310-140	\$0.30	NUT	2	
30	325-150	\$1.20	CLEVIS PIN	all	1
31	280-930	\$5.05	PEDAL PAD, brake & clutch	all	2
32	180-335	\$4.75	SPRING, pedal return	948 & 1098	2
	329-350	\$1.95	SPRING, pedal return	1275 & 1500	2

No.	Part No.	Price (each)	Description	Application	Qty. Req.
35	180-655	\$57.95	SLAVE CYLINDER, 7/8" bore	948 & 1098	1
	180-665	\$114.95	SLAVE CYLINDER, 1" bore, Lockheed	1275	1
	180-667	\$49.95	SLAVE CYLINDER, 1" bore, aftermarket	1275	1
36	180-935	\$4.05	REPAIR KIT	948 & 1098	1
	180-945	\$14.95	REPAIR KIT	1275	1
37	180-100	\$3.60	BLEEDER SCREW	948 & 1098	1
38	180-200	\$10.95	PUSH ROD, 2 1/2" *	948 - 1098	1
	180-595	\$11.95	PUSH ROD, 2 11/16" *	1275	1
39	582-590	\$1.05	CLEVIS PIN	} 948-1275	1
40	475-150	\$0.90	BOLT, slave cyl. mounting		2
45	180-820	\$17.95	HOSE	} 1275	1
	180-821	\$13.95	HOSE, aftermarket		1
46	324-720	\$0.90	COPPER WASHER		1
47	311-420	\$2.75	NUT		1
48	324-180	\$0.45	LOCK WASHER	1	
50	180-705	\$56.95	SLAVE CYLINDER, Girling	} 1500	1
51	180-955	\$5.80	REPAIR KIT		1
52	180-080	\$2.80	BLEEDER SCREW		1
53	190-935	\$10.95	PUSH ROD, 3 1/16" *		1
54	180-845	\$48.95	HOSE		1

* Dimensions given are from hole center to end.

† Note: From 1968 to '80, either one of two master cylinders was fitted. One is identified by either of the markings shown below. The other has no such markings. The master cylinder assemblies are interchangeable, but the internal parts are not.

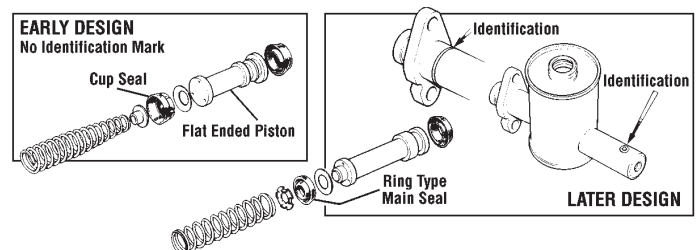

Gearbox 948-1275

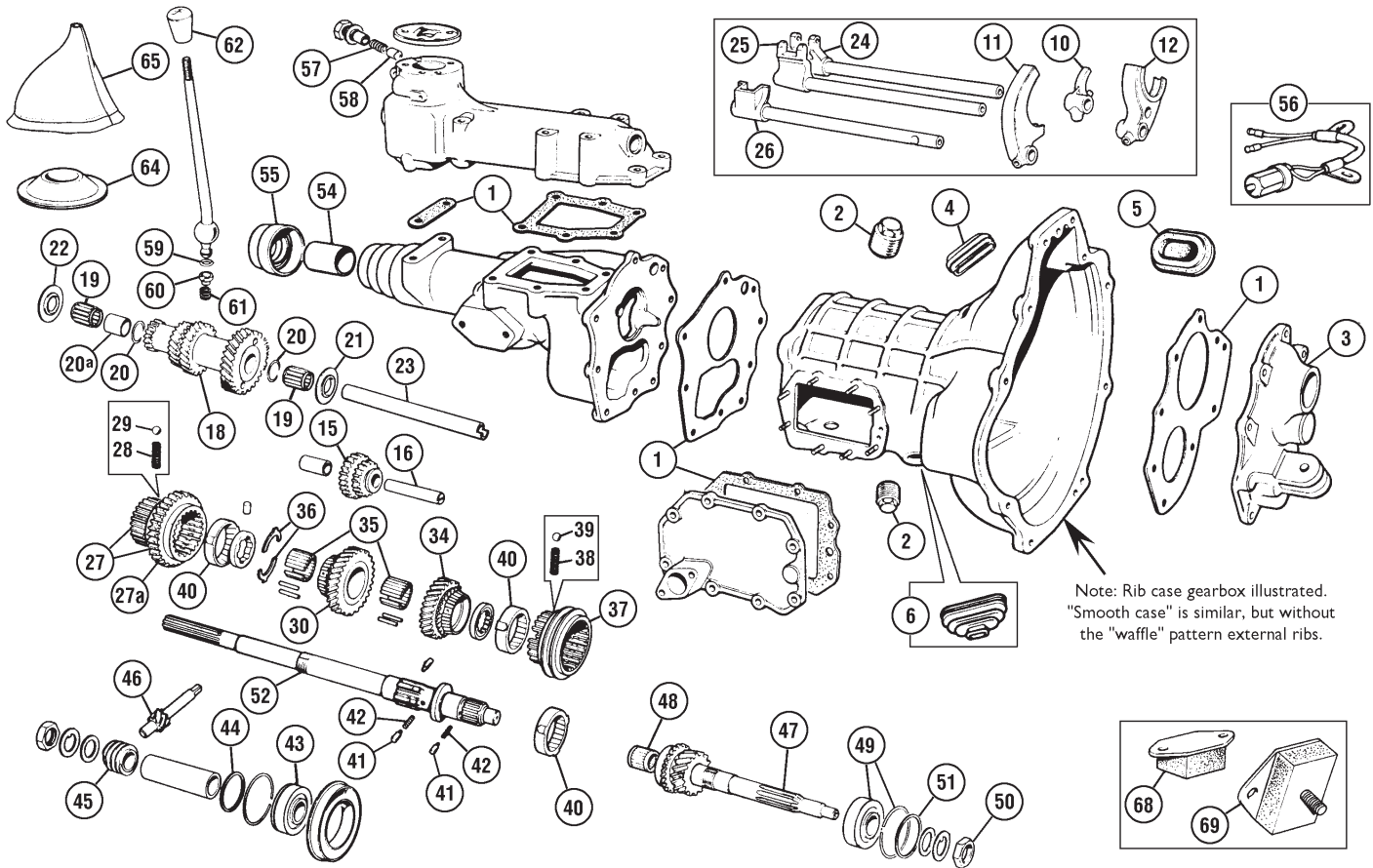

No.	Part No.	Price (each)	Description	Application	Qty. Req.
1	297-700	\$4.95	GASKET SET		1
2	328-055	\$7.95	PLUG, drain & filler		2
3	461-765	\$134.95	COVER, front		1
4	461-870	\$6.65	DUST COVER, top		1
5	461-875	\$5.95	DUST COVER, side		1
6	461-010	\$4.75	BOOT, release arm		1
10	461-880	NA	REVERSE FORK		1
11	461-885	\$29.95	FORK, 1st & 2nd		1
12	461-890	NA	FORK, 3rd & 4th		1
15	461-895	\$51.95	REVERSE GEAR	{ 1098 from (e)10CC/4642 and 1275	1
16	461-900	NA	SHAFT, reverse gear	all	1
18		NA	LAYGEAR	948	1
	843-100	NA	LAYGEAR (22G76)	{ 1098 all (e)10CG & to (e)CC/4641, to mid 1964	1
	461-905	\$152.95	LAYGEAR (22G1100)	{ 1098 from (e)10CC/4642 and 1275	1
19	127-010	\$9.95	BEARING ASS'Y., laygear Bearings supplied are the later type with a cage. These may be used on early gearboxes which originally had loose rollers between two "washers". Do not re-use these washers when installing the new bearings.		2
20	326-990	\$2.40	CIRCLIP, layshaft bearings		2
20a	NA	NA	SPACER		1
21	461-915	\$12.95	THRUST WASHER, front		1
22	461-920	\$12.95	THRUST WASHER, rear, .123 - .124"		A/R
	461-925	\$12.95	THRUST WASHER, rear, .125 - .126"		A/R
	461-930	\$12.95	THRUST WASHER, rear, .127 - .128"		A/R
	461-935	\$12.95	THRUST WASHER, rear, .130 - .131"		A/R
23	461-940	\$33.95	LAYSHAFT		1
24	461-845	NA	ROD, reverse	} 1098 & 1275	1
25	461-855	NA	ROD, 3rd & 4th		1
26	461-865	NA	ROD, 1st & 2nd		1

No.	Part No.	Price (each)	Description	Application	Qty. Req.
27		NA	1st GEAR ASS'Y., w/synchro cone	948	1
	461-955	NA	1st GEAR ASS'Y.	{ 1098 (e)10CG & to (e)10CC/4641, to mid 1964	1
	461-950	NA	1st GEAR ASS'Y.	{ 1098 from (e)10CC/4642 and 1275	1
27a	461-956	\$123.95	1st GEAR	{ 1098 (e)10CG & to (e)10CC/4641, to mid 1964	1
	461-945	\$89.95	1st GEAR	{ 1098 from (e)10CC/4642 and 1275	1
28	329-305	\$0.90	SPRING		3
29	329-600	\$0.65	BALL		3
30		NA	2nd GEAR, w/ synchro cone	948	1
		NA	2nd GEAR	{ 1098 all (e)10CG & to (e)CC/4641, to mid 1964	1
	843-040	\$143.95	2nd GEAR	{ 1098 from (e)10CC/4642 and 1275	1
34		NA	3rd GEAR, w/ synchro cone	948	1
		NA	3rd GEAR	{ 1098 all (e)10CG & to (e)10CC/4641, to mid 1964	1
	843-050	NA	3rd GEAR	{ 1098 from (e)10CC/4642 and 1275	1
35	461-960*	\$0.95	NEEDLE ROLLER, 2nd & 3rd gears (26 required per gear)	52	
* Very early (9C) gearboxes used the bushes listed below instead of rollers.					
	461-775	\$68.95	BUSH, 2nd gear	} 9C gearboxes only	1
	461-785	NA	BUSH, 3rd gear		1



MOSS MOTORS, LTD. TOLL-FREE ORDERS 1-800-667-7872

No.	Part No.	Price (each)	Description	Application	Qty. Req.
36	461-835	NA	SPLIT WASHER		2
37		NA	SYNCHRO HUB ASS'Y., 3rd & 4th	948	1
	461-965	NA	SYNCHRO HUB ASS'Y., 3rd & 4th	1098 & 1275	1
38	329-305	\$0.90	SPRING		3
39	329-600	\$0.65	BALL		3
40	461-970	\$19.95	SYNCHRO RING	1098 & 1275	3
41	461-795	\$0.55	PEG	9C uses 1	1/3
42	329-215	NA	SPRING	9C uses 1	1/2
43	127-040	\$26.95	BEARING, mainshaft	948	1
	127-020	\$39.95	BEARING, mainshaft	1098 & 1275	1
44	461-975	\$2.85	SHIM, .004"		A/R
	461-980	\$1.95	SHIM, .006"		A/R
	461-985	\$2.95	SHIM, .010"		A/R
45	461-805	\$22.95	GEAR, speedo drive		1
46	461-810	\$69.95	PINION, speedo drive		1
46a	461-815	NA	PINION HOUSING		1
47		NA	1st MOTION SHAFT, input shaft	948	1
		NA	1st MOTION SHAFT	{ 1098 all (e)10CG & to (e)10CC/4641, to mid '64	1
	461-910	NA	1st MOTION SHAFT	{ 1098 from (e)10CC/4642 and 1275	1
48	330-600	\$5.95	BUSH, mainshaft spigot	9C gearboxes only	1
	127-030	\$6.95	BEARING, mainshaft spigot	all except 9C	1
49	127-040	\$26.95	BEARING, first motion shaft		1
50	311-315	\$0.45	NUT, 1st motion shaft		1
51	461-975	\$2.85	SHIM, .004"		A/R
	461-980	\$1.95	SHIM, .006"		A/R
	461-985	\$2.95	SHIM, .010"		A/R
52		NA	MAINSHAFT	948	1
	461-990	NA	MAINSHAFT	1098 & 1275	1
54	330-550	\$10.30	BUSH, rear mainshaft		1
Note: Bush must be reamed and/or honed to fit yoke spindle after installation.					
55	120-920	\$8.95	OIL SEAL, rear		1
56	141-020	NA	SWITCH, reverse lamp	1275	1
57	329-010	\$0.95	SPRING		1
58	462-440	\$2.95	PLUNGER, anti-rattle		1
59	290-955	\$0.40	RING		1
60	461-825	\$5.95	BUSH		1
61	329-195	\$1.95	SPRING		1
62	462-770	NA	SHIFT KNOB	948 - use 462-775 knob	1
	462-775	\$13.95	SHIFT KNOB	1098, 1275 thru 1971	1
	462-785	\$24.95	SHIFT KNOB	1275, 1972 on	1
64	680-890	\$6.90	SHIFT BOOT, rubber, fits metal cover	{ 948, 1098 1275 thru '71	1
65	462-780	\$18.95	SHIFT BOOT, black vinyl	1275 from 1972	1
68	413-180	\$6.95	MOUNT, center		1
69	413-170	\$10.95	MOUNT, side		2

Most parts for the smooth case transmissions fitted to the Sprite MkII and Midget MkI have been unavailable for many years.

Synchros for these transmissions are "shrunk-on" to the gears and must be machined to fit: an expensive operation requiring an experienced machinist.

Since the ribcase transmissions are less complex and replacement parts are readily available, we recommend the direct replacement of a troublesome smooth case with the ribcase. An added advantage is the more desirable gear ratios fitted to the late units. (The clutch release lever for the ribcase gearbox, #190-955, must be used. However, you must use the release bearing appropriate for the engine installed.)

Eliminating excess free play will do wonders for your clutch action. Since for all practical purposes the clutch is not adjustable, each part must be in top condition. New clevis pins and new slave cylinder push rod are recommended.

Slave cylinder rods should not have sections welded to them to make them longer. This is an erroneous repair which is done to avoid installing a new release bearing. Occasionally a rod from another car is substituted.

Gearbox - 1500 Midget

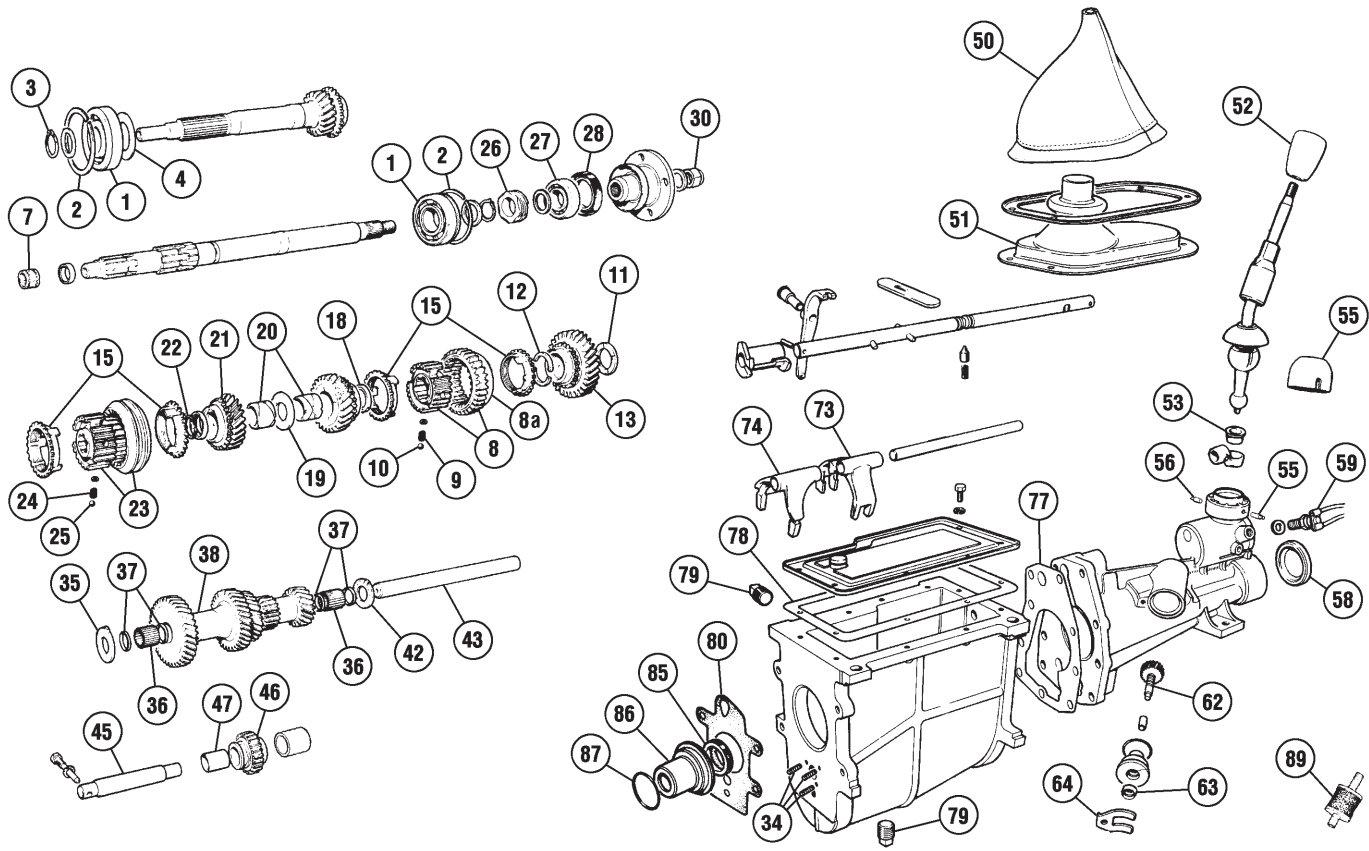

No.	Part No.	Price (each)	Description	Application	Qty. Req.
1500 Gearbox					
	693-060	\$9.95	GASKET SET (includes items marked *)		1
1	071-329	\$57.95	BEARING, input shaft & mainshaft center		2
2	326-745	\$12.95	CIRCLIP, bearing retaining		2
3	326-765	\$0.65	CIRCLIP, input shaft		1
4	848-075	NA	OIL THROWER		1
7	525-190	\$5.45	BEARING, mainshaft spigot		1
8	071-320	NA	SYNCHRO HUB ASS'Y., 1st & 2nd	A - see note below	1
8a	071-342	\$107.95	GEAR, outer	A - see note below	1
	071-321	NA	SYNCHRO HUB ASS'Y., 1st & 2nd	B - see note below	1
9	329-225	\$0.60	SPRING, synchro		3
10	329-510	\$0.55	BALL, synchro		3
11	847-350	\$4.95	THRUST WASHER		1
12	847-475	\$12.95	SPLIT COLLAR, 1st gear		2
13	321-060	NA	1st GEAR		1
15	071-330	\$10.95	SYNCHRO RING		4
18	847-235	\$6.95	THRUST WASHER, 2nd gear		1
19	847-300	\$1.95	THRUST WASHER, .152 - .154"		A/R
	847-310	\$1.95	THRUST WASHER, .156 - .158"		A/R
	847-320	\$2.95	THRUST WASHER, .161 - .163"		A/R
	847-330	\$1.95	THRUST WASHER, .165 - .167"		A/R
	847-340	NA	THRUST WASHER, .169 - .171"		A/R
20	847-290	NA	BUSH, 2nd & 3rd gears		2
21	847-460	\$129.95	3rd GEAR		1
22	326-995	\$1.45	CIRCLIP, mainshaft		1
23	847-410	\$113.95	SYNCHRO HUB ASS'Y., 3rd & 4th		1
24	329-475	\$0.95	SPRING, synchro		3
25	329-510	\$0.55	BALL, synchro		3
26	847-270	\$5.95	GEAR, speedo drive		1
27	525-200	\$23.95	BEARING, mainshaft rear		1
28	520-410	\$5.25	OIL SEAL, rear		1
30	310-485	NA	NUT, mainshaft flange		1
34	847-380	\$1.25	SPRING		3
35	847-230	NA	THRUST WASHER, front		1
36	525-210	\$0.95	NEEDLE ROLLERS		50
37	525-205	\$12.95	RING, roller retaining		4
38	847-240	NA	LAYGEAR (15 teeth on rev. gear)	A - see note below	1
	847-220	NA	LAYGEAR (13 teeth on rev. gear)	B - see note below	1
42	847-250	NA	THRUST WASHER, rear		1
43	071-324	\$21.95	LAYSHAFT		1
45	846-130	\$10.20	SPINDLE, reverse idler		1

No.	Part No.	Price (each)	Description	Application	Qty. Req.
46	071-325	\$46.95	REVERSE IDLER GEAR (21 teeth)	A - see note below	1
	071-326	\$57.95	REVERSE IDLER GEAR (17 teeth)	B - see note below	1
47	330-485	\$2.95	BUSH, reverse idler		1
50	681-135	\$14.95	SHIFT BOOT, vinyl		1
51	681-130	NA	SHIFT BOOT, rubber		1
52	847-260	\$19.95	SHIFT KNOB		1
53	NA	NA	BUSH, shift lever	to gearbox #56469	1
	330-580	\$2.75	BUSH, shift lever	from gearbox #56470	1
55	847-435	\$2.95	PIN, long (L/H side)		1
56	847-430	\$3.15	PIN, short (R/H side)		1
58	848-595	\$2.30	END CAP, tail housing		1
59	542-400	NA	SWITCH, reverse light	thru 1975	1
	542-410	\$10.95	SWITCH, reverse light	1976 on	1
62	847-280	\$49.95	PINION, speedo drive	22 teeth, red	1
	847-420	\$32.95	PINION, speedo drive	21 teeth, green	1
	847-285	\$32.95	PINION, speedo drive	20 teeth, orange	1
63	461-445	\$4.50	OIL SEAL, speedo pinion		1
64	072-395	\$3.95	RETAINER, speedo cable		1
73	847-390	\$169.95	FORK, 1st & 2nd selector		1
74	847-470	NA	FORK, 1st & 2nd selector		1
77	693-040*	\$0.90	GASKET, gearbox to rear extension		1
78	693-050*	\$1.95	GASKET, top cover		1
79	328-340	\$1.35	PLUG, drain & filler		2
	328-355	NA	DRAIN PLUG, magnetic	(optional)	1
80	693-030*	\$1.70	GASKET, bellhousing to gearbox		1
85	520-240	\$4.95	OIL SEAL, front	when fitted	1
86	848-585	NA	COVER, front		1
87	290-960	\$1.70	O-RING		1
89	810-140	\$5.95	MOUNT, transmission		2

1500 Gearbox Notes

To extend gearbox life, British Leyland designed a modified gear set consisting of a new 1st/2nd synchro hub assembly, laygear, and reverse idler gear. Components with the application "A" above were originally fitted up to gearbox #241363, gears above with the application "B" were originally fitted from gearbox #241364. Over the years, many early gearboxes were fitted with the later gears. To avoid confusion, please count your reverse gear teeth before ordering.

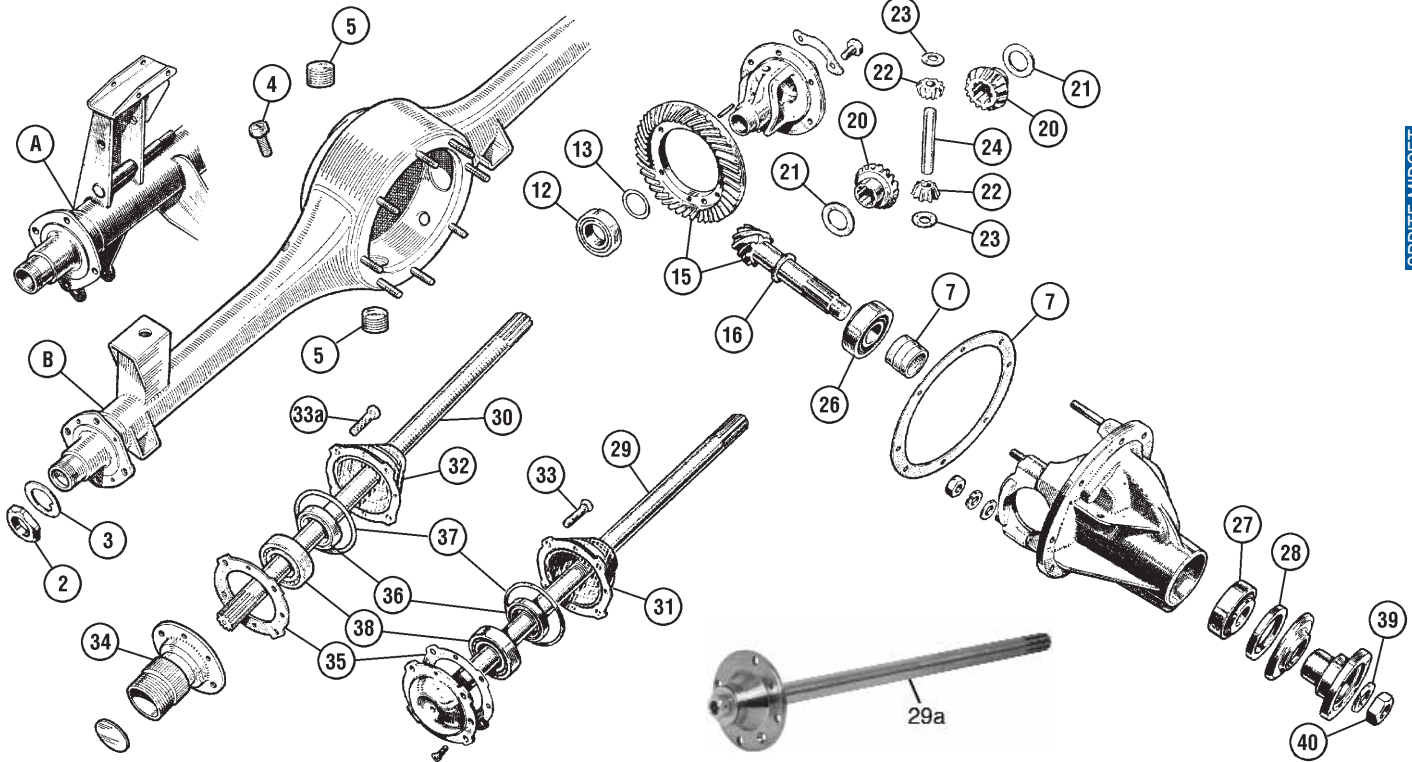

No.	Part No.	Price (each)	Description	Application	Qty. Req.
A		NA	AXLE ASSEMBLY (1/4 elliptic springs)	Sprite MkI, MkII Midget MkI	1
B		NA	AXLE ASSEMBLY (1/2 elliptic springs)	Sprite MkIII-on Midget MkII-1500	1
2	311-620	\$8.00	NUT, R/H hub (RH threads)		1
	461-260	\$9.95	NUT, L/H hub (LH threads)		1
3	265-560	\$1.95	TAB WASHER		2
4	267-040	\$3.70	BREATHER		1
5	319-060	\$2.95	DRAIN/FILLER PLUGS		2
7	294-210	\$1.85	GASKET, differential		1
12	127-300	\$29.95	BEARING, differential		2
13	265-320	\$2.40	SHIM, bearing, .002"		A/R
	265-330	\$1.95	SHIM, bearing, .003"		A/R
	265-340	\$1.95	SHIM, bearing, .004"		A/R
	265-350	\$1.95	SHIM, bearing, .010"		A/R
15		NA	GEAR SET, 4.22:1	axle ass'y "A"	1
	265-360	NA	GEAR SET, 4.22:1 (9 x 38 teeth)	axle ass'y "B"	1
	265-370	\$299.95	GEAR SET, 3.90:1 (10 x 39 teeth)	(will not fit ass'y "A")	1
	265-375	\$339.95	GEAR SET, 3.73:1 (11 x 41 teeth)		1
16		NA	SHIMS, 0.116"-0.130", Not Available		A/R
17		NA	SPACER		1
20	265-240	NA	DIFFERENTIAL GEAR		2
21	265-250	\$2.95	THRUST WASHER		2
22	265-260	\$34.95	PINION, differential		2
23	265-270	\$6.65	THRUST WASHER, differential pinion		2
24	265-280	\$36.95	PINION AXLE		1
25	265-290	NA	LOCKING PIN, pinion axle		1
26	125-130	NA	BEARING, rear inner pinion	axle ass'y "A"	1
	125-150	\$20.95	BEARING, rear inner pinion	axle ass'y "B"	1
27	125-805	\$30.95	BEARING, front outer pinion	axle ass'y "A"	1
	125-140	\$28.95	BEARING, front outer pinion	axle ass'y "B"	1
28	120-800	\$2.80	OIL SEAL	all	1
29	265-300	\$226.95	AXLE SHAFT, disc wheels		2
29a	265-305	\$325.00	AXLE SHAFT, disc wheels, competition	UK-made competition axles have flanges retained by splines and nut instead of stock taper. Flange and shaft made from much stronger steels than stock axles.	2
30	265-310	\$149.95	AXLE SHAFT, wire wheels		2
31	265-210	NA	BEARING HUB, disc wheels		2
32	265-215	NA	BEARING HUB, wire wheels		2
33	265-540	\$4.90	STUD, disc wheels		8
33a	265-550	\$9.80	STUD, wire wheels		8

No.	Part No.	Price (each)	Description	Application	Qty. Req.
34	265-220	NA	EXTENSION, R/H, wire wheels	Sprite MkII Midget MkI	1
	265-225	NA	EXTENSION, L/H, wire wheels		1
	265-230	\$157.95	EXTENSION, R/H, wire wheels	from Sprite MkIII	1
	265-235	\$157.95	EXTENSION, L/H, wire wheels	Midget MkII-1500	1
	125-830	\$24.95	HUB BEARING KIT, incl. #3, 35, 36, 37, 38		2
35	296-030	\$0.95	GASKET, hub		2
36	120-030	\$5.95	OIL SEAL		2
37	121-410	\$1.95	O-RING		2
38	125-120	\$18.95	BEARING, hub		2
39	324-100	\$0.40	LOCKWASHER		1
40	310-570	\$2.95	NUT		1



Speedi-Sleeve

Differential pinion seal. (use for differential flange)
When a new seal cannot compensate for excessive damage, this ultra-thin sleeve provides a "new" sealable surface. Instructions and installation tool are included.
520-515 \$34.45

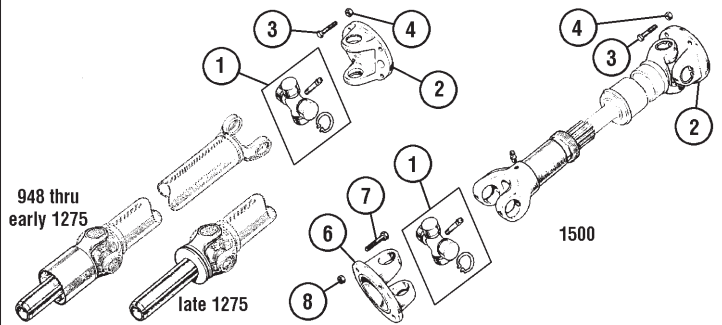

No.	Part No.	Price (each)	Description	Application	Qty. Req.
1	268-060	\$16.95	U-JOINT, OE Hardy-Spicer brand	} all	2
2	268-010	\$24.95	FLANGE to differential		1
3	322-310	\$0.55	BOLT to differential flange	} 1500	4
4	310-290	\$0.65	NUT, nyloc		4
6	674-925	\$48.95	FLANGE to gearbox		1
7	320-395	NA	BOLT to gearbox flange		4
8	310-240	\$0.75	NUT, nyloc		4

Steering Wheels

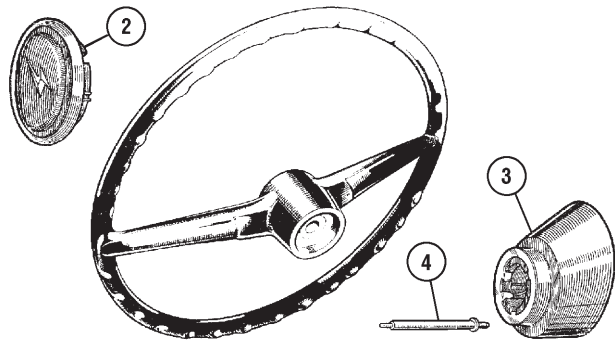

2	408-125	\$39.95	HORN PUSH	Sprite 948	1
	408-135	\$34.95	HORN PUSH	Midget 948	1
3	233-215	\$106.95	SURROUND (does not incl. slip ring)	} Sprite Mkl, MkII Midget MkI	1
4	560-430	\$10.95	HORN BRUSH		1
	667-590	\$20.95	SLIP RING*		1

*Slip ring has a plastic base - remove it for this application.

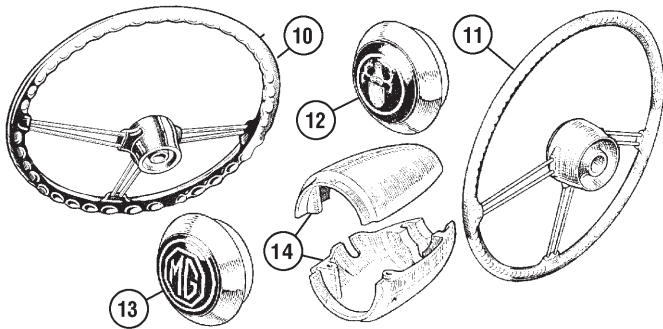

10	453-865	\$249.95	STEERING WHEEL	1964 - '67	1
11	453-960	\$159.95	STEERING WHEEL	1968 - '69	1
12	408-155	NA	HORN PUSH	Sprite 1964 - '67	1
13	408-145	NA	HORN PUSH	Midget 1964-'67	1
14	233-205	\$28.95	COWL, steering column	1964-'69	1

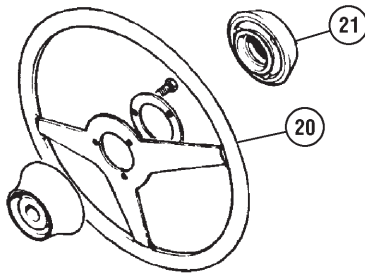

20	263-720	NA	STEERING WHEEL	Midget from GAN5-135882	1
21	408-275	\$40.95	CENTERPIECE, steering wheel	fits Midget from 1970-on	1

Note: This wheel will fit all Midgets from 1970, but does not have cut-outs in the spokes.

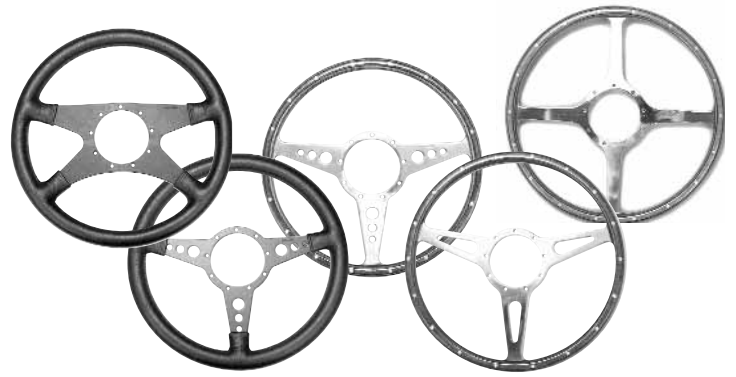

Accessory Steering Wheels

Hand crafted steering wheels employ the finest bicolored wood laminations or smooth leather over aircraft quality aluminum frames. Personalize your car with these classic steering wheels. Simply choose the wheel you want and, then order the correct hub for your car.

Wood Rim Steering Wheels

489-070	14" with 3 Drilled Matte Spokes	\$219.95
489-060	15" with 3 Drilled Matte Spokes	\$219.95
489-080	15" with 3 Slotted Matte Spokes	\$219.95
454-245	15" with 4 Solid Polished Spokes	\$379.95

Leather Rim Steering Wheels

489-040	14" with 3 Drilled Black Spokes	\$199.95
489-030	14" with 3 Drilled Matte Spokes	\$199.95
905-700	14" with 4 Solid Black Spokes	NA
489-010	15" with 3 Drilled Black Spokes	\$199.95
489-050	15" with 3 Slotted Black Spokes	\$199.95

Adaptor Hubs with Emblems - Sprite

905-345	Sprite Mkl & II - with 28mm plastic emblem	\$94.95
905-346	Sprite Mkl & II - with 46mm enamelled emblem	\$96.95

454-365	Sprite MkIII, IV thru '67 - with 28mm plastic emblem	\$94.95
454-368	Sprite MkIII, IV thru '67 - with 46mm enamelled emblem	\$96.95

905-472	Sprite MkIV 1968-69 - with 28mm plastic emblem	\$94.95
905-478	Sprite MkIV 1968-69 - with 46mm enamelled emblem	NA

Adaptor Hubs with Emblems - Midget

905-345	Midget Mkl - with 28mm plastic emblem	\$94.95
905-348	Midget Mkl - with 46mm enamelled emblem	\$96.95

454-365	Midget MkII, III thru '67 - with 28mm plastic emblem	\$94.95
454-366	Midget MkII, III thru '67 - with 46mm enamelled emblem	\$96.95

905-470	Midget MkIII, 1968-69 - with 28mm plastic emblem	\$94.95
905-468	Midget MkIII, 1968-69 - with 46mm enamelled emblem	NA

905-475	Midget MkIII, 1970 only - with 28mm plastic emblem	\$94.95
905-476	Midget MkIII, 1970 only - with 46mm enamelled emblem	NA

905-480	Midget 1971-'76 - with 28mm plastic emblem	\$94.95
905-482	Midget 1971-'76 - with 46mm enamelled emblem	\$96.95



Classic Steering Wheel

A slightly thicker rim than our other classic wooden wheels for a more positive grip (approx. 28mm or 1.1" in diameter). It also features non-glare matte finish spokes and rich solid mahogany wood. This will fit any of our classic steering wheel adaptor hubs.
489-090 \$219.95

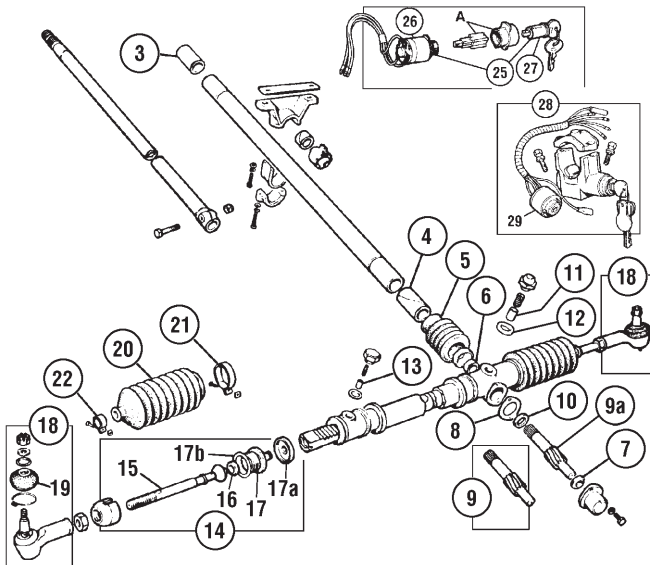

948 - 1098 - early 1275 Steering

No.	Part No.	Price (each)	Description	Application	Qty. Req.
3	667-600	\$5.60	BUSH, upper, felt	} non-collapsible steering columns	1
4	263-420	\$6.55	BUSH, lower, felt		1
5	280-880	\$8.30	SEAL, steering col. to toe board		1
6	120-040	\$0.90	OIL SEAL, pinion	} MG to (c)60440; AH to (c)72033, thru approx. '67	1
	120-050	NA	OIL SEAL, pinion		} MG from (c)60441 to 114486 AH from (c)72034 on, approx. 1968 thru '72
7	260-220	NA	THRUST WASHER, pinion bottom	} all Sprite Midget to GAN5-114486	
8	260-230	NA	SHIM, lower pinion bearing, .003"		A/R
	260-240	NA	SHIM, lower pinion bearing, .005"		A/R
	260-250	NA	SHIM, lower pinion bearing, .010"		A/R
9	663-310	\$10.85	STEERING PINION, w/flat on splines		1
9a	663-300	\$62.95	STEERING PINION, w/groove on splines		1
10	663-320	\$0.95	THRUST WASHER, pinion top		1
11	262-190	\$17.95	DAMPER PAD, pinion		1
12	262-120	\$3.15	SHIM, .003"		A/R
	260-270	NA	SHIM, .010"		A/R
13	263-040	\$4.65	DAMPER PAD, secondary		1
14	260-330	\$115.95	TIE ROD ASSEMBLY		2
15	260-280	NA	TIE ROD		2
16	260-290	\$65.95	SOCKET		2
17	262-160	\$169.95	BALL HOUSING		2
17a	262-110	\$7.95	LOCK WASHER	2	
17b	262-130	NA	SHIM, .003"	A/R	
	262-140	NA	SHIM, .005"	A/R	
	262-150	NA	SHIM, .010"	A/R	
18	263-288	\$32.95	TIE ROD END, pair	1	
19	262-220	\$2.80	BOOT, tie rod end	2	
20	260-320	\$16.95	RACK SEAL	2	
21	263-230	\$1.65	CLAMP, large	2	
22	326-325	\$1.05	CLAMP, small	2	
25	263-600*	NA	IGNITION SWITCH ASS'Y.	} MG from (c)60441-74885 AH from HAN9-72034 on	1
26	141-220*	\$16.95	IGNITION SWITCH		1
27	163-500*	\$13.95	LOCK BARREL w/2 keys		1

*U.S. spec column mounted ignition switches are locking-type. Ignition switch #141-220 is similar to the original, but has Lucar spade terminals in place of the wires found on the original switches. To use this replacement switch, three wires approximately 14" long must be attached to the switch with female Lucar connectors (#161-520). To connect the other ends of these wires to your harness, use wire tips, #162-200, and connectors, #162-000. Parts marked "A" in the illustration are no longer available and must be re-used from your old switch assembly.

28	263-610	\$139.95	LOCK & SWITCH ASSEMBLY	} MG from (c)74886 to 114486	1
29	263-655	NA	SWITCH		1

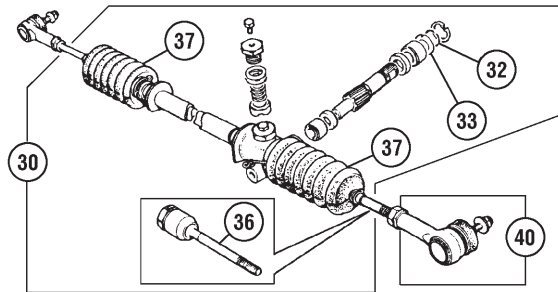
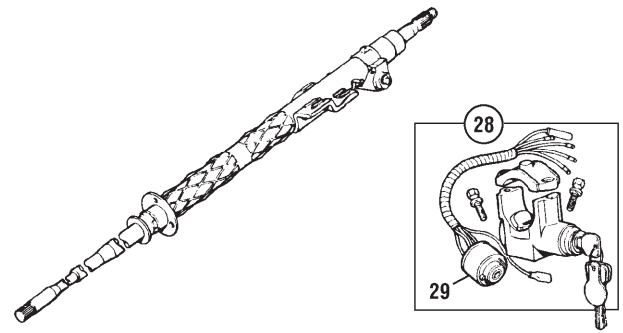

Late 1275 & 1500 Steering

28	263-610	\$139.95	LOCK & SWITCH ASSEMBLY	} MG from (c)114487 to 154100	1
29	263-655	NA	SWITCH		1
	263-640	\$167.95	LOCK & SWITCH ASSEMBLY	} Midget 1500, 1975 on	1
	263-690	\$76.95	SWITCH		1
30	668-000	NA	STEERING RACK ASSEMBLY	} MG 1275 from (c)114487 & 1500	1
32	290-920	NA	O-RING		1
33	668-010	NA	SHIM, .005"		A/R
	668-020	\$0.90	SHIM, .010"		A/R
36	668-030	NA	TIE ROD & BALL ASS'Y., inner		2
37	680-058	\$17.95	RACK BOOT SET, 2 boots		1
40	668-040	\$35.95	TIE ROD END SET		1

The most common causes of steering shake are wheel imbalance, tire belt separation, bad shock absorbers and worn wheel bearings. Harder to find problems arise from loose steering rack mounts and out-of-round brake rotors. The most elusive shake is caused by wear in the steering rack itself. This is an unfamiliar problem just coming into its own, due to the age of the affected cars.

The problem manifests itself in localized intermittent shaking in the steering wheel, and is difficult to sort out as most suspension problems end up being felt through the steering wheel. A clue is afforded by determining which parts of the car are shaking as well as the steering wheel. If the cowl or fenders are shaking, the problem lies with suspension parts, not the rack.

There is much you can do to eliminate shake and shimmy not connected with the rack. See that everything is mounted properly and securely as your safety depends on your steering system being in first class operating condition.

Front Suspension

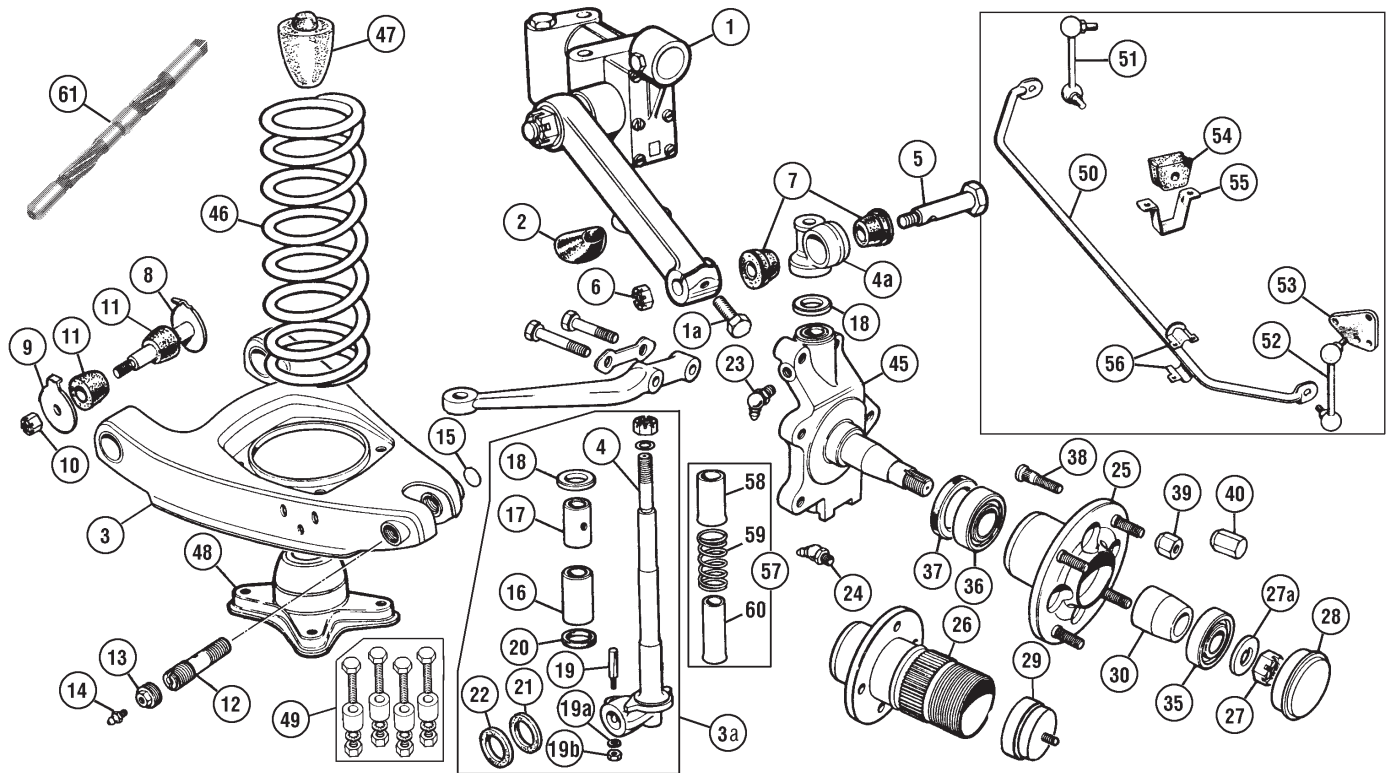

No.	Part No.	Price (each)	Description	Application	Qty. Req.
1	264-000	\$159.95	SHOCK ABSORBER, R/H, new		1
	264-005	\$159.95	SHOCK ABSORBER, L/H, new		1
	264-015	\$104.95	SHOCK ABSORBER, R/H, rebuilt		1
		\$50.00	CORE CHARGE FOR 264-015 SHOCK ABSORBER		
	264-025	\$104.95	SHOCK ABSORBER, L/H, rebuilt		1
		\$50.00	CORE CHARGE FOR 264-025 SHOCK ABSORBER		
1a	322-410	\$0.95	CLAMP BOLT		2
2	264-055	\$5.95	BUFFER, rebound		2
3	264-065	\$206.95	WISHBONE/SPRING PAN (British Motor Heritage part)		2
	264-078*	\$190.95	MAJOR SUSPENSION KIT (includes items marked*)	} 948 only drum brakes	1
3a	264-185*	\$149.95	SWIVEL PIN REPAIR KIT		1
	264-195*	\$64.95	FULCRUM PIN REPAIR KIT §	2	
	264-088†	\$235.95	MAJOR SUSPENSION KIT (includes items marked†)	} 1098, 1275, 1500 disc brakes	1
3a	264-205†	\$86.95	SWIVEL PIN REPAIR KIT		1
	264-195†	\$64.95	FULCRUM PIN REPAIR KIT §		2
§ Fulcrum pin repair kits include #5-14, 19-19b, 21-24.					
4	*	NA	SWIVEL PIN	948	2
	†	NA	SWIVEL PIN	1098, 1275, 1500	2
4a	264-405	\$39.95	TRUNNION		2
5	264-045*†	\$9.95	PIN, upper fulcrum		2
6	311-640*†	\$1.50	NUT		2
	325-330*†	\$0.25	COTTER PIN for nut		2
7	330-520*†	\$6.95	BUSH, top		4
8	264-145*†	\$8.95	BOLT with washer, inner fulcrum		4
9	324-395*†	\$3.15	WASHER, inner fulcrum		4
10	310-240*†	\$0.75	NUT, inner fulcrum bolt		4
11	282-310*†	NA	BUSH, wishbone		8
12	264-075*†	\$18.95	FULCRUM PIN		2
13	328-455*†	\$2.50	PLUG		2
14	328-610*†	\$1.10	GREASE NIPPLE		2
15	328-014*†	\$0.95	PLUG, blanking		2
16	*	NA	BUSH, lower†	948	2
	330-400†	\$3.85	BUSH, lower†	1098, 1275, 1500	2
17	*	NA	BUSH, upper†	948	2
	330-540†	NA	BUSH, upper†	1098, 1275, 1500	2
18	*†	NA	THRUST WASHER		2

No.	Part No.	Price (each)	Description	Application	Qty. Req.
19b	310-040*†	\$0.15	NUT		2
20	*†	NA	SEAL		2
21	264-425*†	\$1.50	SEAL, small cork		2
22	264-435*†	\$1.95	SEAL, large cork		2
23	328-505*†	\$0.95	GREASE NIPPLE, top		2
24	328-500*†	\$0.95	GREASE NIPPLE, bottom		2
25	264-245	NA	HUB, disc wheel		2
26	264-225	NA	HUB, R/H, wire wheels	} Sprite MkII Midget MkI	1
	264-235	\$138.95	HUB, L/H, wire wheels		1
	264-255	\$182.95	HUB, R/H, wire wheels	} from Sprite MkIII, Midget MkII	1
	264-265	\$182.95	HUB, L/H, wire wheels		1
27	310-085	\$1.45	NUT		2
27a	264-952	\$3.70	WASHER		2
28	264-515	\$10.95	GREASE CAP, disc		2
29	662-030	\$6.80	GREASE CAP, wire		2
30	264-625	\$9.60	BEARING SPACER		2
	125-820•	\$69.95	WHEEL BEARING KIT	(2 bearings & oil seal)	2
35	126-010•	\$21.95	BEARING, outer		2
36	126-020•	\$35.95	BEARING, inner		2
•See page 35 for important bearing information.					
37	120-910	\$4.45	OIL SEAL		2
38	264-415	\$4.05	STUD, disc wheels	drum brakes	8
	264-095	\$2.95	STUD, disc wheels	disc brakes	8
39	264-215	\$1.95	LUG NUT, plain, disc wheels		8
40	264-155	\$2.95	NUT, chrome for Rostyle wheels		8
45	264-275	NA	SWIVEL AXLE, R/H	} 1098, 1275, 1500 disc brakes	1
	264-285	NA	SWIVEL AXLE, L/H		1
46	265-590	\$49.95	SPRING	to HAN8-58380, GAN3-46040	2
	265-610	\$38.95	SPRING	} from HAN8-58381 on GAN3-46041 to GAN6-171477	2
	265-620	\$33.95	SPRING		GAN6-171478 on
	264-605	\$77.95	COMPETITION SPRING, 340 lb/in,	slightly lowers car	2
	264-615	\$69.95	COMPETITION SPRING, 400 lb/in,	lowers car approx. 1"	2
47	264-295	\$6.75	SUSPENSION BUFFER		2

Note: † These bushes must be reamed or honed to fit the swivel pin being installed in the swivel axle. Consult workshop manual for instructions and dimensions.

19	264-445*†	\$3.40	PIN		2
19a	324-010*†	\$0.15	LOCKWASHER		2

No.	Part No.	Price (each)	Description	Application	Qty. Req.
48	264-305	\$48.95	SPRING SEAT		2
49	264-665	\$23.95	LOWERING KIT lowers car approx. 1/2"		1
50	264-105	\$58.95	SWAY BAR (anti-roll bar)		1
51	264-115	\$29.95	LINK, R/H		1
52	264-125	\$29.95	LINK, L/H		1
53	264-135	\$6.80	BRACKET		2
54	280-920	\$1.95	RUBBER MOUNT		2
55	263-430	\$1.95	STRAP		2
56	263-778	\$4.40	LOCATOR PAIR with hardware		2
57	264-638	\$16.95	DUST TUBE KIT	drum brakes	2
58	264-315	\$9.75	DUST TUBE, upper	}all	2
59	264-655	\$0.95	SPRING, dust tubes		2
60	264-635	NA	DUST TUBE, lower	drum brakes	2
	264-645	\$6.95	DUST TUBE, lower	disc brakes	2
61	386-380	\$302.95	REAMER, king pin bushes	disc braked cars	1

Front Suspension



SPRITE-MIDGET

Alignment Gauge

Setting toe-in yourself used to be a big giant hassle, but one which needs doing. Every time you work on your car's front end, the toe should be checked and adjusted. With this inexpensive but accurate gauge, simply take a measurement at the back of the front tires, measure at the front, and read the difference on the large scale. Adjust your tie-rods by the indicated amount, and check by re-measuring. It's that easy! This handy alignment gauge will pay for itself the first time you use it.

387-085 \$42.95



Competition Front Coil Springs

For serious competition, we recommend this 400 lbs. spring rate front coil spring. Lowers standard ride height by one inch. Fits chrome bumper cars. Available on special order only. Please allow 6-8 weeks for delivery. **264-615 \$69.95 ea.**

Lowered Front Coil Springs

For chrome bumpered cars, this spring slightly lowers the ride height while providing a useful increase in spring rate to 340 lbs./in.

264-605 \$77.95 ea.

Front suspension Lowering Kit

This kit contains special spacers which install between the wishbone/spring pan and the spring seat to lower your front suspension one half inch. Works with all springs. Kit includes spacers and bolts for both sides.



264-665 \$23.95

Nylatron Upper Trunnion Bushes

Nylatron bushings firmly locate your front suspension and eliminate unnecessary movement. Standard camber trunnion bushings are a direct replacement for your original bushings. The negative camber bushings are designed primarily for competition purposes and give improved steering and braking control. Sold individually, 4 required per car.

Standard Camber Bushing 264-585 \$12.95
Negative Camber Bushing 264-595 \$14.95

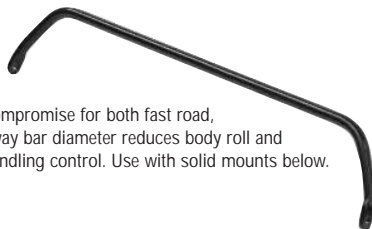

3/4" Anti Sway Bar

The 3/4" anti sway bar is an excellent compromise for both fast road, and competition use. Increased front sway bar diameter reduces body roll and understeer which in turn gives better handling control. Use with solid mounts below. **264-555 \$170.95**



Solid Sway Bar Mounts

Machined aluminum mounts may be employed for road use, but were primarily designed for competition purposes. Some increase in road noise can be expected. Use with 3/4" bars. Sold as a pair. **263-435 \$80.95**

Front Suspension Advice

The front suspension will give good service if kept clean and lubricated. Few Spridgets receive this attention, and inspection is impossible without a thorough cleaning. Front end condition should be considered before purchasing a car.

There should be no play in the steering or hub assemblies. Inspect the tie rod ends, hubs and uprights. The front end must be raised. Allow the suspension to hang by placing jack stands on the frame next to the engine or under the rocker panels. Have someone turn the steering wheel from lock to lock while you observe the tie rod ends, which must not have any free play.

Lower king pin bushes and fulcrum pin and wishbone attachments wear out. Grasp the wheel at top and bottom and rock back and forth. (Figure A) Observe any clearance at the king pin and fulcrum pin. If the wheel rocks but there is no "gap" at the fulcrum pin, the hub bearings must be inspected. (Figure B)

All Spridgets eventually need front end rebuild. The use of new parts is best, as the fulcrum pin often fuses to the wishbone. Few of these parts are reusable.

Severe wear on the lever link is a problem with the single arm shocks. Check by removing the upper link and wiggling the arm back and forth (Figure C). If fluid leaks from the the shaft seals, replace the shocks and top bushes.

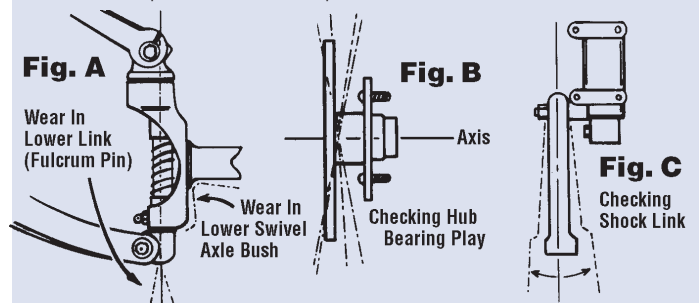

"Stiff steering" can be caused by hardened grease in the lower king pin bushes.

Temporary improvement can be made by removing the grease fittings and applying heat to melt out hardened grease. Work the steering from lock to lock while heating. When the joints seem "free", install new fittings and pump grease through the bush. Grease a second time after the joints are cold.

Replacement of the drive shaft is difficult and frustrating as you cannot reach nor see down the tunnel to guide the front flange. Support the front joint with a couple of pieces of cardboard or styrofoam placed across the coupling to hold the flange relatively straight. The spine is then easily mated to the transmission.

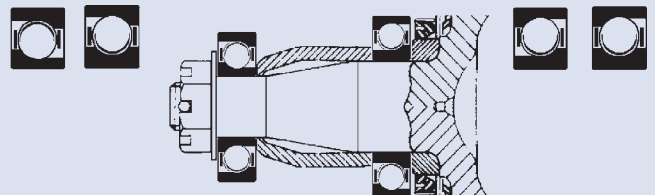

Front Wheel Bearings

Front wheel bearings are thrust bearings; if installed backwards, the hubs may come loose from the axles. Bearings marked "thrust" on the outer race must have this marking face the bearing spacer. Bearings marked "thrust" on the inner races must be installed with the "thrust" marking away from the bearing spacer. Bearings with no "thrust" markings must be installed with the thicker edge of the outer races facing inwards toward the bearing spacer. The illustration above shows the correct orientation of different available bearings. Note the orientation of the thrust (thick) and non-thrust (thin) sides of the bearing races.

Rear Suspension

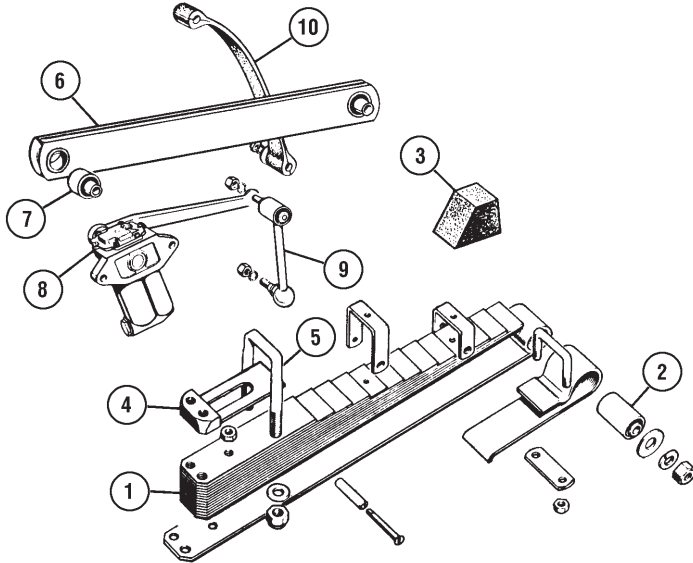

No.	Part No.	Price (each)	Description	Application	Qty. Req.
1/4 Elliptic System					
1	265-460	NA	SPRING ASSEMBLY, standard	15 leaves	2
	265-630	\$101.95	SPRING ASSEMBLY, rally spec.	10 leaves	2
2	680-960	\$9.65	BUSH, silentbloc (supplied with spring)		2
3	282-220	\$7.95	BUMP RUBBER		2
4	265-600	\$14.95	SPRING PLATE		2
5	265-570	\$22.95	U-BOLT		2
	310-400	\$0.80	NUT, U-bolts		4
6	265-380	\$51.95	RADIUS ARM	} Sprite Mkl & MkII Midget Mkl	2
7	265-390	\$12.95	BUSH		4
8	265-400	\$167.95	SHOCK ABSORBER, new L/H		1
	265-410	\$167.95	SHOCK ABSORBER, new R/H		1
	265-405	NA	SHOCK ABSORBER, rebuilt L/H		1
		NA	CORE CHARGE FOR 265-405 SHOCK ABSORBER		
	265-415	NA	SHOCK ABSORBER, rebuilt R/H		1
		NA	CORE CHARGE FOR 265-415 SHOCK ABSORBER		
9	265-420	\$28.95	LINK, shock absorber		2
10	267-610	\$8.95	STRAP, rebound		2



Safety Knock-Off Wrench

This cleverly designed long handle wrench allows you to tighten or remove octagon "safety" or "eared" spinners without a hammer. Stores easily in the trunk.

386-120	"Safety Knockoff" Wrench	\$48.95
386-125	"Eared Knockoff" Wrench	\$48.95
386-115	Fabric Wrench Cover	\$15.95

Protective Knockoff Wrench

Prevent damage to knock-offs with this multiply wooden wrench.

386-165	\$31.95
---------	---------

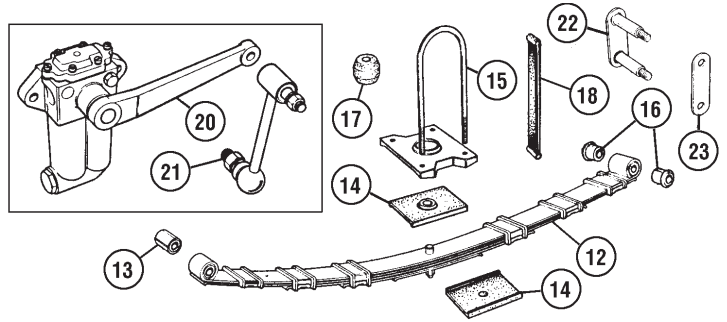

No.	Part No.	Price (each)	Description	Application	Qty. Req.
1/2 Elliptic System					
12	265-490	\$86.95	SPRING	} MG MkII & MkIII AH MkIII & MkIV	2
	264-685	\$146.95	SPRING, lowered 1"		2
	264-705	\$202.95	SPRING, lowered 2"		2
	265-500	\$89.95	SPRING	Midget 1500	2
13	266-410	\$6.70	BUSH, silentbloc (supplied with springs)		2
14	280-900	\$2.95	PAD, seating		4
15	265-395	\$2.95	U-BOLT		4
	310-240	\$0.75	NUT, U-bolts		8
16	280-905	\$1.65	BUSH, shackle		8
17	266-530	\$10.95	BUMP RUBBER		2
18	267-610	\$8.95	STRAP, rebound	948 thru 1275	2
	267-615	\$8.95	STRAP, rebound	Midget 1500	2
20	265-430	\$167.95	SHOCK ABSORBER, new L/H	} Midget from MkII on Sprite from MkIII on	1
	265-440	\$167.95	SHOCK ABSORBER, new R/H		1
	265-435	\$89.95	SHOCK ABSORBER, rebuilt L/H		1
		\$50.00	CORE CHARGE FOR 265-435		
	265-445	\$89.95	SHOCK ABSORBER, rebuilt R/H		1
		\$50.00	CORE CHARGE FOR 265-445		
21	265-450	\$29.95	LINK, shock absorber		2
22	265-455	\$19.95	SHACKLE PLATE, with pins		2
23	265-465	\$7.90	SHACKLE PLATE		2

Lowered Rear Leaf Springs

Lowered springs are preferred to blocks and long U-bolts because they provide better location of the rear axle. Our 1" lowered springs are perfectly suited to fast road use. The 2" springs are appropriate for the track. Fit chrome-bumpered cars only from 1964-'74.

1964-'74 Rear Leaf Spring, 1" Lowered	264-685	\$146.95
1964-'74 Rear Leaf Spring, 2" Lowered	264-705	\$202.95

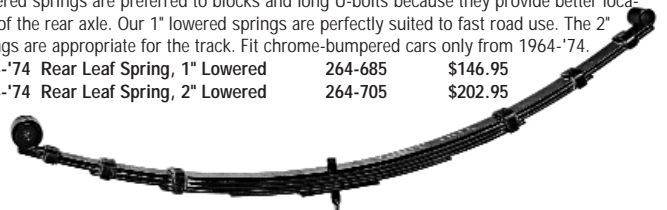

Rear Tube Shock Conversion Kit

Fits 1964 to 1974 chrome bumper models. These kits contain the Spax adjustable gas filled shocks (adjustable from the outside),

with new lower spring plates that incorporate an angled mounting flange. Installation is easy, and instructions are included.

264-675	\$491.95
---------	----------

Early Type Jack Bag

Styled like the original factory-supplied jack bag made from heavy duty jute-backed vinyl. Complete with straps and buckles. Keeps the jack from banging around, a must for the restored car.

386-930	\$26.95
---------	---------



Road Wheels & Tools



Bright Trim Rings

Deluxe, polished stainless steel trim rings. Our trim rings install in seconds and provide an attractive accent to your Rostyle disc wheels. Sold individually.
453-045 \$13.95

Inner Tubes and Rim Bands

Top quality heavy-duty tube designed for use with radial tires and have rubber covered valve stems. (Can be used with bias-ply tires.)

145 x 13" Inner Tube 452-725 \$18.95 ea.
155/165 x 13" Inner Tube 452-715 \$16.95 ea.



We offer high quality vulcanized rubber rim bands in all popular sizes. Prevent spoke and nipple ends from chafing your inner tubes.

13" Rim Band 452-730 \$14.95 ea



Bolt-On Sport Wheels

Exact replica of the original Mini-lite wheel is an alternative to steel wheels. Give your British sports car a modern, aggressive look. Wheels bolt on using lug nuts listed below.
13" x 5" Wheel 453-065 \$172.95
Lugnut (ea.) 264-495 \$1.45



Silver Wheel Paint

The correct shade of silver-grey for your disc or wire wheels.
220-560 \$14.95

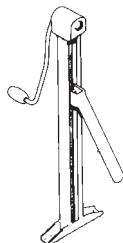

1500 Jack

Original style jack for use or to complete your show car.
386-920 \$169.95

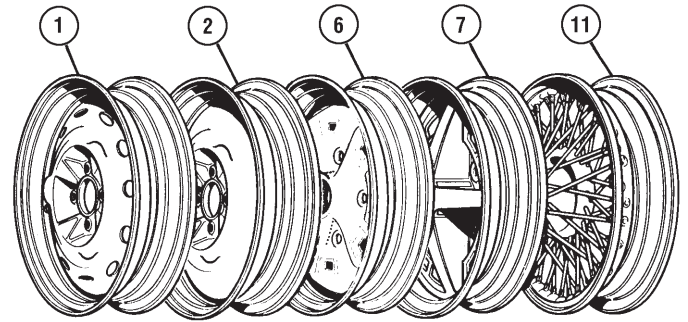

SPRITE-MIDGET

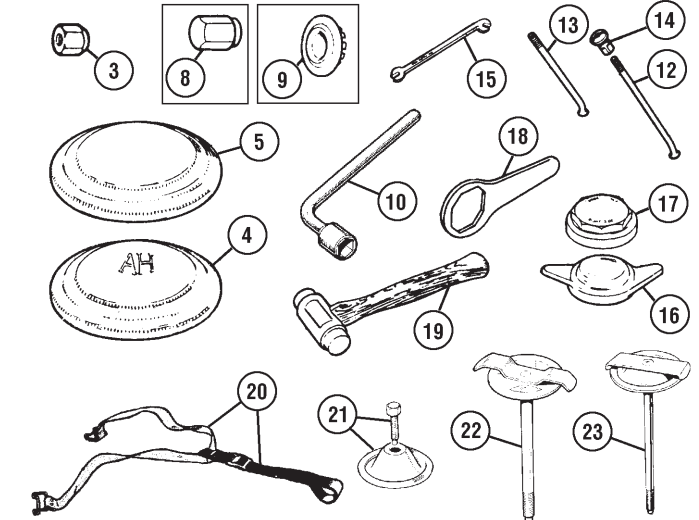

No.	Part No.	Price (each)	Description	Application	Qty. Req.
1		NA	WHEEL, steel, vented	948	5
2	455-450	NA	WHEEL, steel, non-vented	1098	5
3	264-215	\$1.95	LUG NUT, plain, disc wheels		16
4	200-340	\$38.65	HUBCAP, "AH"	} 948 & 1098	4
5	200-350	\$32.50	HUBCAP, plain for Midget		4
6	455-455	NA	WHEEL, Rostyle	1275	5
7	455-460	NA	WHEEL, Rostyle	1500	5
8	264-155	\$2.95	NUT, chrome	} 1275 & 1500	16
9	462-765	\$8.95	HUBCAP		4
	462-745	\$2.55	MG EMBLEM, hubcap		4
10	386-035	\$19.95	LUG WRENCH	disc wheels	1
11	454-675	\$198.95	WIRE WHEEL, painted	} 13 x 4", 60 spoke	5
12	200-370*	\$5.60	SPOKE, long, plain		20
13	200-380*	\$5.60	SPOKE, short, plain		40
14	200-050*	\$1.05	NIPPLE, plain		60
	454-685	\$303.95	WIRE WHEEL, chromed	} 13 x 4", 60 spoke	5
	200-390*	NA	SPOKE, long, chromed		20
	200-400*	\$3.85	SPOKE, short, chromed		40
	200-052*	\$1.80	NIPPLE, chromed		60
15	385-800	\$9.95	SPOKE WRENCH		1
16	200-290	\$36.95	KNOCK-OFF, R/H, eared	} Sprite MkII	2
	200-280	\$36.95	KNOCK-OFF, L/H, eared		} Midget MkI (12 t.p.i.)
	674-670	\$39.95	KNOCK-OFF, R/H, eared	} from Sprite MkIII	2
	674-680	\$39.95	KNOCK-OFF, L/H, eared		} Midget MkII (8 t.p.i.)
17	200-320	\$36.95	KNOCK-OFF, R/H, octagonal	} 12 t.p.i.	2
	200-310	\$36.95	KNOCK-OFF, L/H, octagonal		2
	310-315	\$35.95	KNOCK-OFF, R/H, octagonal	} "MG" crested	2
	310-305	\$35.95	KNOCK-OFF, L/H, octagonal		} 12 t.p.i.
	462-740	\$36.95	KNOCK-OFF, R/H, octagonal	} 8 t.p.i.	2
	462-730	\$36.95	KNOCK-OFF, L/H, octagonal		2
18	386-030	\$9.55	SPANNER, octagonal knock-offs		1
19	386-000	\$28.95	HAMMER, copper/copper faces		1
	386-020	\$29.95	HAMMER, solid lead alloy head		1
	386-110	\$37.95	HAMMER, copper/rawhide faces, 2 lbs.		1
20	385-950	\$19.95	STRAP SET, spare tire	Bugeye	1
21	386-135	NA	CLAMP, spare wheel	std. steel wheels 1961-'67	1
22	386-145	NA	CLAMP, spare wheel	Rostyle wheels 1970-'80	1
23	386-155	NA	CLAMP, spare wheel	wire wheels 1961-'80	1

LOCAL & OVERSEAS: 805-681-3400

FAX: 805-692-2525 www.mossmotors.com



Brake Hydraulics

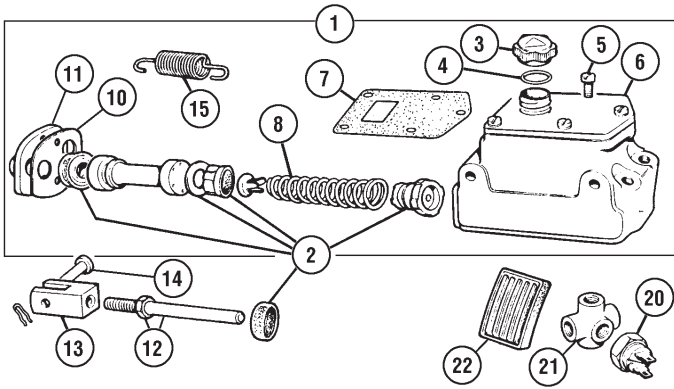

No.	Part No.	Price (each)	Description	Application	Qty. Req.
-----	----------	--------------	-------------	-------------	-----------

Brake Hydraulics - 948 & 1098

1	180-670	\$466.95	MASTER CYLINDER, 7/8" bore	948 drum brakes	1
	180-555\$SUG		180-670 MASTER CYLINDER, 3/4" bore (180-670 may be used)	1098 front disc brakes	1
2	180-970*	\$14.95	REPAIR KIT, clutch & brake, 7/8"	948	1
	180-565*	\$14.95	REPAIR KIT, clutch & brake, 3/4"	1098	1
* These repair kits may include a replacement type brake cylinder check valve, or the rubber cup for the original check valve.					
3	180-210	\$5.95	CAP, plastic replacement	} 948 & 1098	1
4	180-450	\$3.45	WASHER, cap		9/7
5	323-500	\$1.00	SCREW, front & top covers		1
6		NA	COVER		1
7	180-270	\$2.95	GASKET		1
8	180-030	\$3.10	SPRING	948	2
	181-710	\$4.00	SPRING	1098	2
10	180-020	\$1.95	GASKET	} 948 & 1098	1
11	180-010	NA	PLATE		1
12	180-305	\$8.65	PUSH ROD		2
13	180-315	\$10.95	FORK		2
14	180-325	\$4.60	CLEVIS PIN		2
15	180-335	\$4.75	SPRING, pedal return	2	
20	141-700	\$9.95	SWITCH, brake light, screw conn.	Bugeye	1
	542-110	\$9.95	SWITCH, brake light, spade conn.	948, 1098	1
21	180-230	NA	UNION, 4-way plus switch		1
	180-090	\$20.95	UNION, 3-way, rear		1
	322-247	\$0.30	BOLT, union to frame		1
	324-020	\$0.20	LOCKWASHER for bolt		1
22	280-930	\$5.05	PEDAL PAD, brake & clutch		2

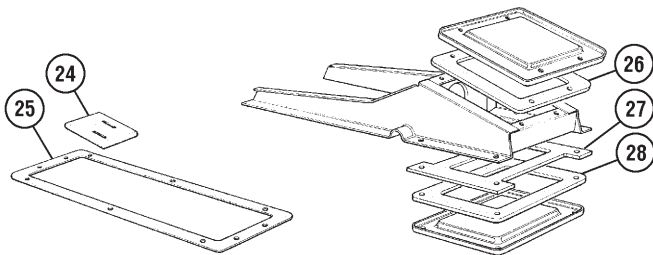

Pedal Box Seals

24	280-085	\$1.95	EXCLUDER, fume & dust	} 948 & 1098	1
25	280-125	\$2.50	SEAL, pedal box to firewall		1
	280-125	\$2.50	SEAL, pass. side blanking plate	all	1
26	280-127	\$2.25	SEAL, top cover	} 1275 & 1500	1
27	280-126	\$2.35	SEAL, pedal box to firewall		1
28	280-128	\$2.25	SEAL, bottom blanking plate		1

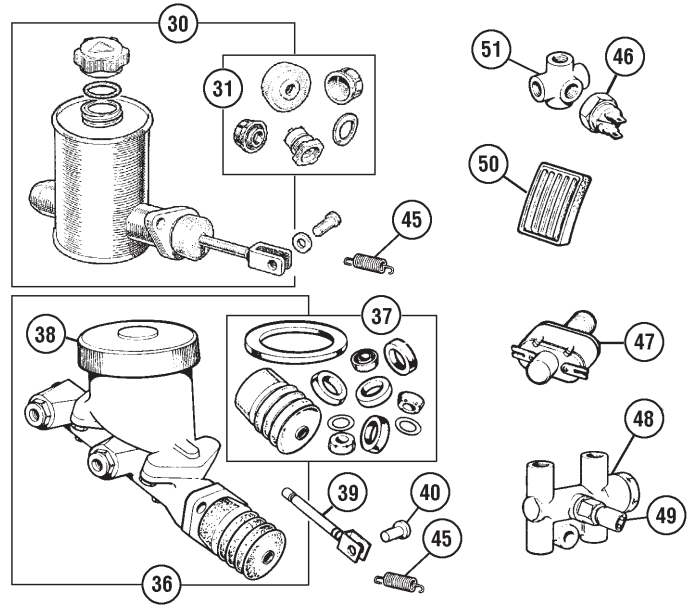

No.	Part No.	Price (each)	Description	Application	Qty. Req.
-----	----------	--------------	-------------	-------------	-----------

Brake Hydraulics - 1275 & 1500

30	180-585	\$108.95	MASTER CYLINDER	} some 1967 cars single line system	1
31	180-875	\$5.90	REPAIR KIT, cyls. not marked*		1
	180-905	\$10.90	REPAIR KIT, marked cyls.* *see illustration below		1
36	180-345	\$252.95	MASTER CYLINDER	} 1275 & 1500 dual line system	1
37	180-205	\$18.95	REPAIR KIT		1
38	180-215	\$17.95	CAP		1
39	181-695	NA	PUSH ROD		1
40	325-135	\$1.30	CLEVIS PIN		1
45	329-350	\$1.95	SPRING, pedal return	1275 & 1500	2
46	542-110	\$9.95	SWITCH, brake light, spade conn.	1275 (1967)	1
47	181-980	\$23.95	SWITCH, brake light	1275 from 1968, 1500	1
48	141-710	\$543.95	SWITCH ASS'Y., brass (replacement)	1275 & 1500 thru 1975	1
	141-720	NA	SWITCH ASS'Y., cast iron	1500 from 1976-on	1
49	181-955	\$37.95	SWITCH for original brass ass'y.		1
	542-115	NA	SWITCH for cast iron ass'y.		1
	181-995	\$6.60	REPAIR KIT		1
50	280-930	\$5.05	PEDAL PAD, brake & clutch		2
51	180-230	NA	UNION, 4-way plus switch	1275 single line system	1
	180-090	\$20.95	UNION, 3-way, rear		1

Note: 1967 single line systems used either one of two master cylinders. The earlier has no identifying marking. The later has either of the markings shown below. The master cylinder assemblies are interchangeable, but the internal parts are not.

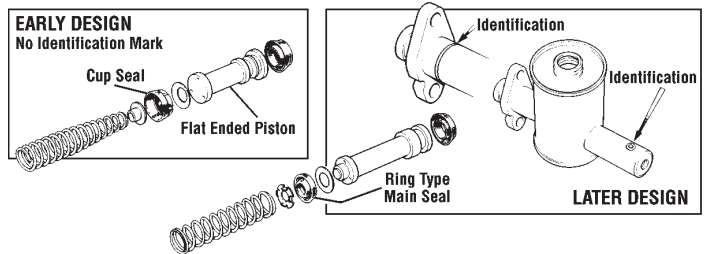

moss

MOSS MOTORS, LTD. TOLL-FREE ORDERS 1-800-667-7872

Drum Brakes

SPRITE-MIDGET

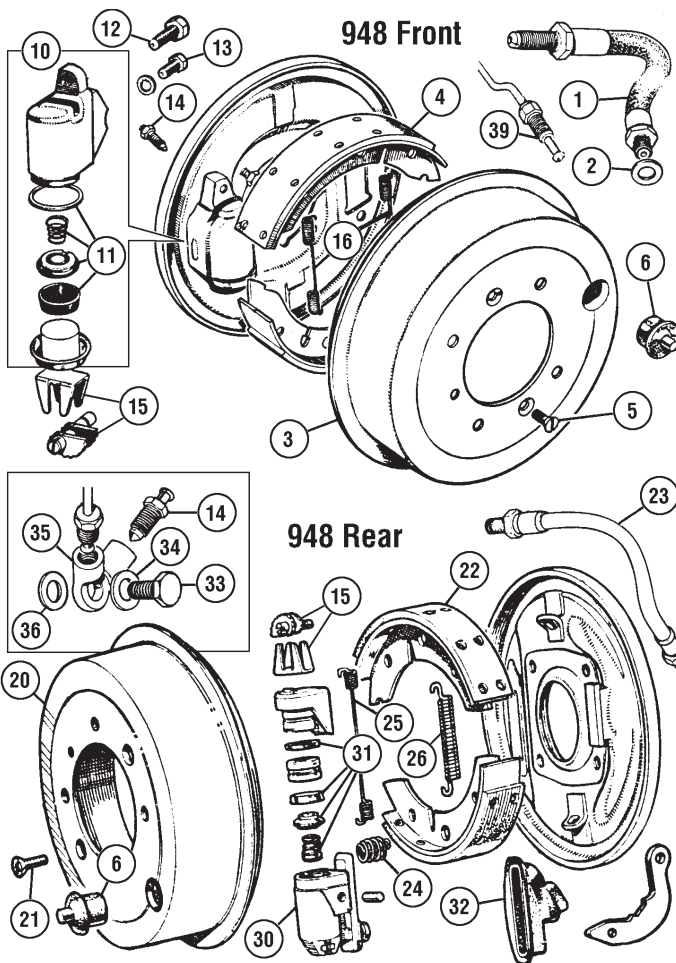

No.	Part No.	Price (each)	Description	Application	Qty. Req.
33	180-130	\$8.00	BANJO BOLT	} Sprite to HAN6-20544 Midget to GAN1-1355	2
34	324-720	\$0.90	WASHER, large copper		2
35	180-460	\$38.95	BANJO FITTING		2
36	324-730	\$0.40	WASHER, small copper		2
39	181-125	NA	PIPE, between ft. wheel cylinders		2

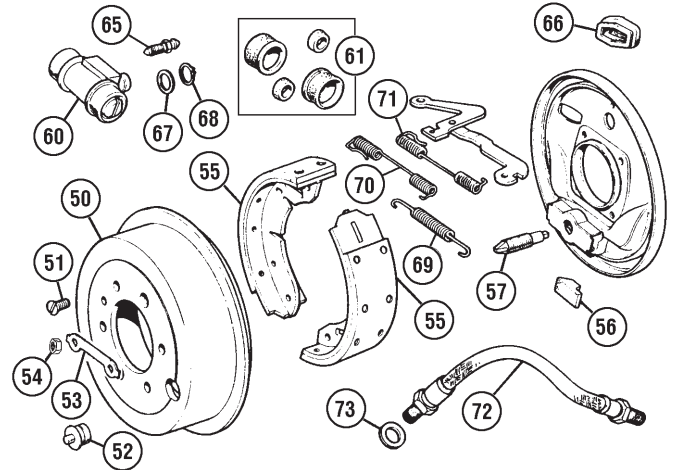

Late 948 thru 1500 Rear Brakes

50	181-885	\$32.95	BRAKE DRUM, rear		2
51	323-255	\$0.75	SCREW, drum to hub		4
52	181-975	\$1.95	PLUG		2
53	181-915	\$0.95	TAB WASHER	} wire wheels	4
54	310-075	\$0.40	NUT		8
55	182-175	\$17.95	BRAKE SHOE SET		1
56	181-895	\$5.40	ADJUSTER TAPPET		4
57	181-905	\$6.75	ADJUSTER WEDGE		2
60	180-445	\$163.95	WHEEL CYLINDER, 7/8"	} Sprite (c)20545 to 24731 Midget (c)13555 to 16183	2
	180-446	\$38.95	WHL. CYLINDER, aftrmrkt*		2
61	180-480	\$8.45	REPAIR KIT		2
	180-385	\$24.95	WHEEL CYLINDER, 3/4"	} 1098 & 1275	2
	180-386	\$15.95	WHEEL CYLINDER, 3/4", aftermarket*		2
	180-405	\$7.30	REPAIR KIT (not for aftermarket clys.)		2
	180-395	\$24.95	WHEEL CYLINDER, rear	} 1500	2
	180-396	\$15.95	WHEEL CYLINDER, rear, aftermarket*		2
	071-526	\$4.80	REPAIR KIT (not for aftermarket clys.)		2
65	323-145	\$1.95	BLEED NIPPLE (incl. with wheel cylinders)		2
66	181-760	\$4.95	BOOT	all	2
67	180-575	NA	WASHER, cylinder retaining	} original fitment	2
68	326-945	\$1.20	CIRCLIP		2
	326-720	.00	"C" CLIP, cylinder retaining	replaces #67 & 68	2
69	182-665	\$2.95	SPRING, abutment end		2
70	182-670	\$4.95	SPRING, R/H, cylinder end		1
71	182-675	\$4.95	SPRING, L/H, cylinder end		1
72	180-895	\$21.95	HOSE, rear brake		1
	180-896	\$13.95	HOSE, rear brake, aftermarket		1
73	324-730	\$0.40	WASHER, copper		1

* No rebuild kits are available for these aftermarket wheel cylinders.

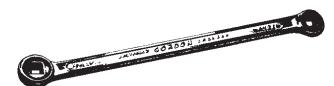

Brake Adjuster Wrench

Forged from high strength steel, this wrench has 1/4" and 5/16" square holes for easy brake adjustment. **386-160 \$12.95**

No.	Part No.	Price (each)	Description	Application	Qty. Req.
-----	----------	--------------	-------------	-------------	-----------

948 Front & Rear Brakes

Rear brakes to G-AN1-13554 and H-AN6-20544 (approx.).

1	180-355	\$19.95	HOSE, front		2
	180-356	\$15.95	HOSE, front, aftermarket		2
2	324-730	\$0.40	WASHER, copper		2
3	181-885	\$32.95	BRAKE DRUM, front		2
4	182-120	\$20.95	BRAKE SHOE SET, front relined		1
5	323-250	\$0.40	SCREW, front drum to hub		4
6	181-975	\$1.95	PLUG, front & rear drums		4
10	180-640	\$37.95	WHEEL CYLINDER, R/H front		2
	180-641	\$20.95	WHEEL CYLINDER, R/H front, aftermarket (no repr. kit available)		2
	180-650	\$37.95	WHEEL CYLINDER, L/H front		2
	180-656	\$20.95	WHEEL CYLINDER, L/H front, aftermarket (no repr. kit available)		2
11	180-458	\$35.95	REBUILD KIT, does 4 cylinders (original cylinders only)		1
	180-180	\$1.00	SPRING		4
	180-170	\$3.25	EXPANDER		4
	180-940	\$6.95	CUP & RING		4
12	322-170	\$0.35	BOLT, large		4
13	322-400	\$2.25	BOLT, small		4
14	180-100	\$3.60	BLEEDER, front & rear		4
15	180-105	NA	ADJUSTER & MASK		4
16	182-680	\$4.20	SPRING, shoe return, front		6
20	181-885	\$32.95	BRAKE DRUM, rear	} Sprite to HAN6-20544 Midget to GAN1-13554	2
21	323-255	\$0.75	SCREW, rear drum to hub		4
22	182-140	\$20.95	BRAKE SHOE SET, rear, relined		1
23	180-895	\$21.95	HOSE, rear		1
	180-896	\$13.95	HOSE, rear, aftermarket		1
24	181-340	\$2.95	SPRING, shoe steadying		4
25	182-655	\$3.95	SPRING, cylinder end		2
26	182-660	\$8.95	SPRING, abutment end		2
30	181-285	\$61.95	WHEEL CYLINDER, rear, w/lever		2
31	180-470	\$36.95	REPAIR KIT, does 2 cylinders		1
32	180-950	\$15.95	BOOT (not incl. with cylinder)	2	

LOCAL & OVERSEAS: 805-681-3400

FAX: 805-692-2525

www.mossmotors.com

MOSS

Disc Brakes / Handbrake

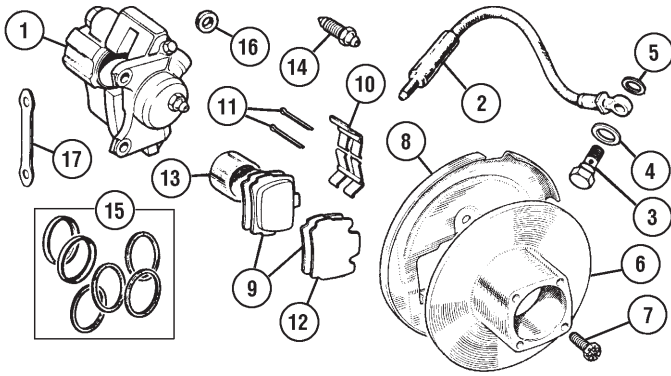

No.	Part No.	Price (each)	Description	Application	Qty. Req.
1	182-700	NA	CALIPER ASS'Y., rebuilt, R/H		1
	182-710	NA	CALIPER ASS'Y., rebuilt, L/H		1
2	180-375	\$19.95	HOSE, front disc brake		2
	180-376	\$17.95	HOSE, front disc brake, aftermarket		2
3	180-430	\$5.95	BANJO BOLT		2
4	324-720	\$0.90	WASHER, copper, large		2
5	324-730	\$0.40	WASHER, copper, small		2
6	182-155	\$29.95	BRAKE ROTOR, disc wheels		2
	182-145	\$28.95	BRAKE ROTOR, wire wheels		2
	586-600	\$198.95	BRAKE ROTOR PAIR, cross-drilled/slotted	disc wheels	1
7	322-435	\$2.85	BOLT, brake rotor		8
8	182-265	\$13.95	DUST COVER, R/H		1
	182-275	\$13.95	DUST COVER, L/H		1
9	585-605	\$64.95	PAD SET, "Hawk"	} see color section at front of this catalog for details	1
	585-625	\$64.95	PAD SET, "Green Stuff"		1
	071-537	\$40.95	PAD SET, semi-metallic		1
	071-536	\$21.95	PAD SET, stock type		1
10	181-965	\$2.95	RETAINER		2
11	325-430	\$0.80	COTTER PIN		4
12	181-935	\$1.95	SHIM, anti-squeal		4
13	181-925	\$18.95	CALIPER PISTON		4
14	180-100	\$3.60	BLEEDER SCREW		2
15	071-514	\$9.95	REPAIR KIT, for one caliper		2
16	180-285*	\$1.50	SEAL, fluid channel, between caliper halves		2
17	181-670	\$0.95	TAB WASHER		2

*This seal is not included in the repair kit, as caliper halves should never be separated. If, for some reason, you have ignored warnings not to do this, this seal is available.



Cross-Drilled Brake Rotors

Stop! Cross drilled rotors cool better for reduced brake fade and scrub off water faster in the wet. Special rotational hole pattern. For disc wheel cars. Sold as pairs only.

586-600 \$198.95

Anti-squeal Strips

Sometimes disc brakes just won't shut up. These foil lined self-adhesive strips stick onto the back of the brake pads to dampen the vibrations which cause brake squeal. Set of four. (Product may vary from photo.) 583-805 \$5.45

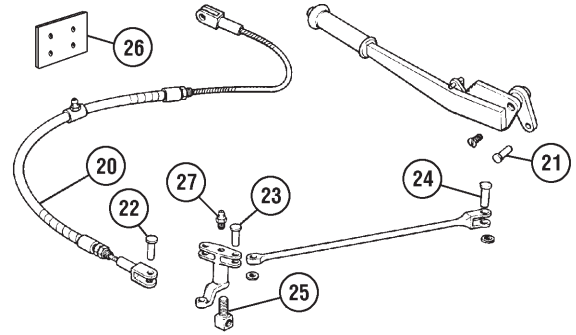

No.	Part No.	Price (each)	Description	Application	Qty. Req.
20	331-660	\$17.95	HANDBRAKE CABLE	} 948 thru 1500 (c)182000	1
21	325-140	\$0.90	CLEVIS PIN, cable to handle		1
22	325-135	\$1.30	CLEVIS PIN, cable to lever		1
23	325-455	\$0.95	CLEVIS PIN, cross-rods to lever		2
24	325-135	\$1.30	CLEVIS PIN, outer ends of rods	} Sprite to (c)20792 Midget to (c)13554	2
	325-130	\$0.60	CLEVIS PIN, outer ends of rods		} Sprite from (c)20793 Midget (c)13555 to 182000
25	182-720	\$5.95	TRUNNION	948 thru 1500 (c)182000	
	331-670	\$19.95	HANDBRAKE CABLE ASSEMBLY	} disc wheels	1
	331-680	\$23.95	HANDBRAKE CABLE ASSEMBLY		} 1500 from (c)182001 on
	325-135	\$1.30	CLEVIS PIN, cable to handle	1	
	325-255	\$1.50	CLEVIS PIN, cable to wheel	2	
26	182-345	\$1.75	STRAP, handbrake cable to axle		1
27	328-500	\$0.95	GREASE NIPPLE		1

moss

MOSS MOTORS, LTD. TOLL-FREE ORDERS 1-800-667-7872

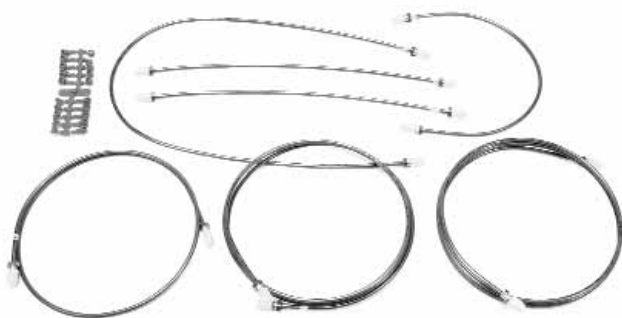

Brake Pipe Sets

Moss brake pipe sets are made in England of high-strength corrosion resistant copper-nickel alloy tubing. Pipes are supplied coiled, but are much easier to bend smoothly and correctly than steel. All pipes come with end fittings and flares, and are individually coded to the instruction sheet so there is no doubt as to where they fit on your car. Note: these pipes have modern universal standard flares which are totally compatible with the original fittings.

184-008	\$114.95	BRAKE PIPE SET	Bugeye	1
184-018	\$111.95	BRAKE PIPE SET	Sprite MkII, Midget Mkl (drum brakes)	1
184-028	\$111.95	BRAKE PIPE SET	1963-'67 (disc brakes)	1
184-038	\$114.95	BRAKE PIPE SET	1968-1974	1
184-048	\$114.95	BRAKE PIPE SET	Midget 1500	1



Brake Pipe Bending Tools

Smooth bends on small diameter tubing such as brake lines are easily made with either of these tools. The small tool bends tubing up to 1/4" diameter. The large tool for repeated heavy use—bends tubing up to 3/8" diameter to a minimum radius of 3/4".

Large	385-895	\$89.95
Small	385-885	\$34.65

Brake Fluids

Choose the brake fluid your car needs. Genuine Lockheed Brake Fluid is compatible with all British brake systems. Silicone fluid won't harm paint, and doesn't absorb moisture, as do conventional fluids. (If changing from one type to the other, flush your brake system thoroughly with the "new" type of brake fluid.)

Lockheed Brake Fluid 500 ml.
220-400 \$5.10

Silicone Brake Fluid 1 qt.
220-410 \$26.95

Castrol Brake Fluid, 12 oz.
220-455 \$5.50



Brake Lube Sachet

This grease is specially formulated for aiding the assembly of natural and artificial rubber brake components. Recommended for use with master cylinder, wheel cylinder and slave cylinder seals. This is the only safe product to use for this purpose, especially if your rebuilt cylinder will not be installed and used immediately after assembly.

220-440 \$2.10

Braided Stainless Steel/Teflon Brake Hose Sets

These competition-inspired brake hose sets meet all DOT safety standards and are street legal in all 50 states. Each set includes all brake hoses used on your car, with any required retaining nuts and/or copper sealing washers.

182-198	Sprite-Midget (with front drum brakes)	\$96.95
182-248	Sprite-Midget (with front disc brakes)	\$96.95



Mityvac

"A useful little sucker." Bleeding hydraulic systems has always been problematic. Wouldn't it be nice if you could use a vacuum to draw fluid through the system, or perhaps generate just a wee bit of air pressure at the master cylinder to force fluid through empty lines? Mityvac is the answer. This clever hand vacuum/pressure pump comes with in depth brake bleeding instructions for not only brake bleeding but also a wealth of other ideas of how Mityvac Kit can help you do the job, quickly.

386-215 \$39.95



Vizibleed Hydraulic Bleeder

This clever tool makes brake and clutch bleeding a one person job. Place the hose over a bleeder screw, put the special check valve in an empty container, open the bleed screw and start pumping the pedal. When clean, air bubble free fluid can be seen in the hose, you're done!

386-885 \$17.95

Hose Clamp Tool

Clamp off your flexible brake hoses before removing cylinders so fluid won't leak out, or air leak in. This handy tool saves time and makes the job a lot neater.

386-855 \$16.50



Body Panels

Most of our body panels are shipped from overseas, and consequently invariably have some scratches and often minor dents. Panels may also require minor alterations to fit your particular car accurately. Please anticipate some clean-up and/or minor modifications. Test fit body panels before modifying or painting - once altered or painted, they are not returnable.

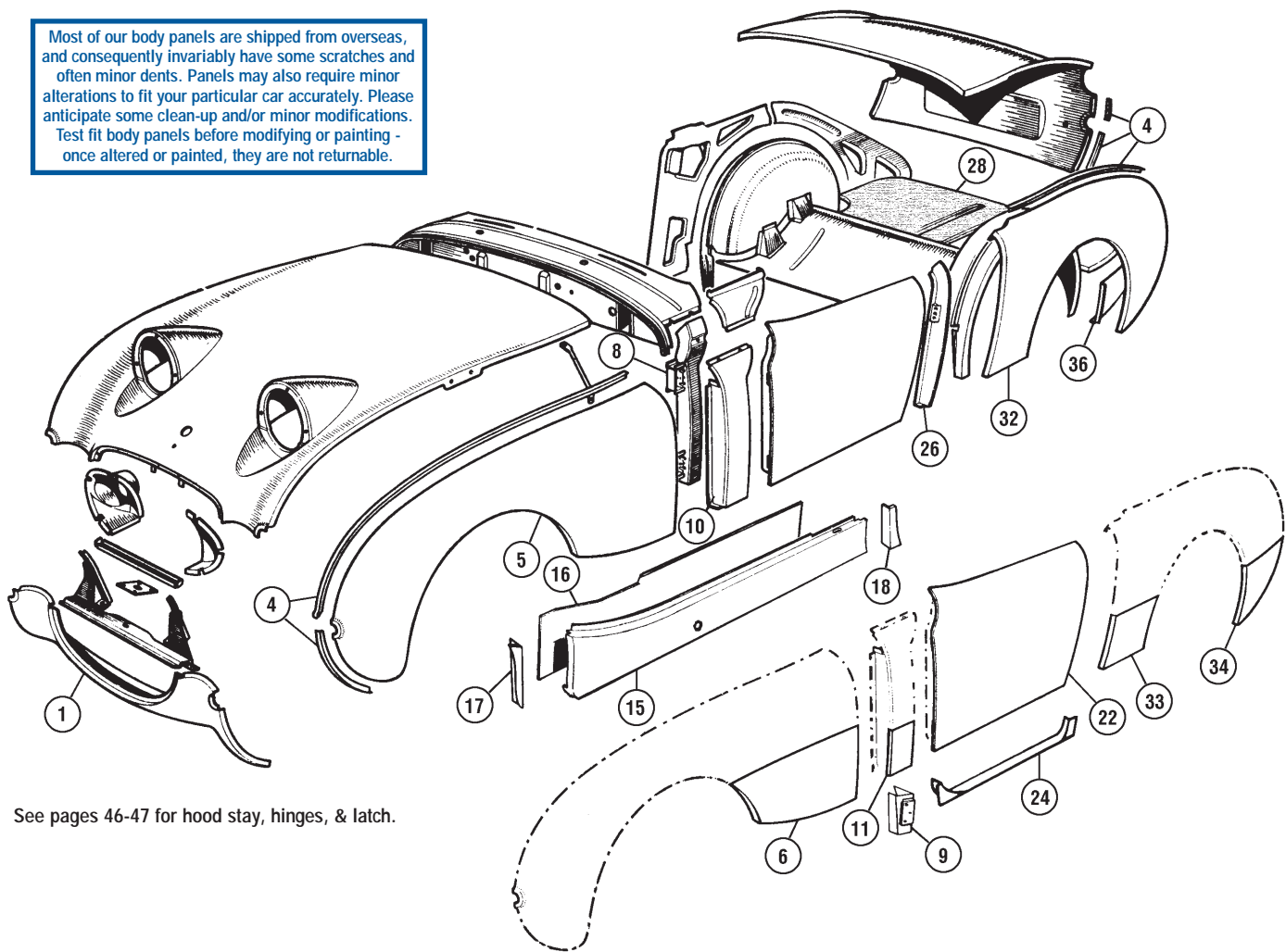

See pages 46-47 for hood stay, hinges, & latch.

No.	Part No.	Price (each)	Description	Application	Qty. Req.
Bugeye Body Panels					
1	452-110	\$377.95	VALANCE, lower front		1
4	457-990	\$18.95	FENDER BEADING	66" length	A/R
5	455-680	\$519.95	FRONT FENDER, L/H		1
	455-670	\$519.95	FRONT FENDER, R/H		1
6	452-120	\$32.95	REPAIR PANEL, L/H		1
	452-125	\$32.95	REPAIR PANEL, R/H		1
8	452-130	\$69.95	"A" POST, inner, L/H		1
	452-135	\$69.95	"A" POST, inner, R/H		1
9	455-065	\$22.95	HINGE MOUNT, lower, L/H		1
	455-055	\$22.95	HINGE MOUNT, lower, R/H		1
10	452-645	\$37.95	"A" POST, outer skin, L/H	} as illus. w/flange	1
	452-655	\$37.95	"A" POST, outer skin, R/H		1
11	455-280	\$6.95	REPAIR PIECE, lower 7 1/2"		2
15	455-495	\$68.95	OUTER SILL, L/H		1
	455-490	\$68.95	OUTER SILL, R/H		1
16	455-445	\$32.95	INNER SILL, L/H		1
	455-440	\$32.95	INNER SILL, R/H		1
17	452-150	\$16.95	END CAP, front, L/H		1
	452-155	\$16.95	END CAP, front, R/H		1
18	452-160	\$16.95	END CAP, rear, L/H		1
	452-165	\$16.95	END CAP, rear, R/H		1
22	452-170	\$177.95	DOOR SKIN, L/H		1
	452-175	\$177.95	DOOR SKIN, R/H		1
24	452-180	\$33.95	REPAIR PIECE, inner door bottom, L/H		1
	452-185	\$33.95	REPAIR PIECE, inner door bottom, R/H		1
26	455-650	\$34.95	"B" POST FACE, L/H		1
	455-640	\$34.95	"B" POST FACE, R/H		1
28	452-190	\$183.95	TRUNK FLOOR		1

No.	Part No.	Price (each)	Description	Application	Qty. Req.
32	455-700	\$549.95	REAR FENDER, L/H		1
	455-690	\$549.95	REAR FENDER, R/H		1
33	452-200	\$23.95	REPAIR PANEL, front, L/H		1
	452-205	\$23.95	REPAIR PANEL, front, R/H		1
34	452-210	\$151.95	REPAIR PANEL, rear, L/H		1
	452-215	\$151.95	REPAIR PANEL, rear, R/H		1
36	452-220	\$32.95	CLOSING PANEL, trunk to fender, L/H		1
	452-225	\$32.95	CLOSING PANEL, trunk to fender, R/H		1

Common Areas of Corrosion

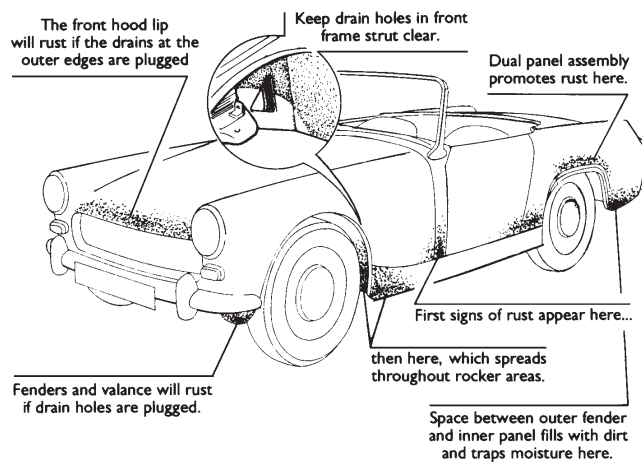

moss

MOSS MOTORS, LTD. TOLL-FREE ORDERS 1-800-667-7872

Most of our body panels are shipped from overseas, and consequently invariably have some scratches and often minor dents. Panels may also require minor alterations to fit your particular car accurately. Please anticipate some clean-up and/or minor modifications. Test fit body panels before modifying or painting - once altered or painted, they are not returnable.

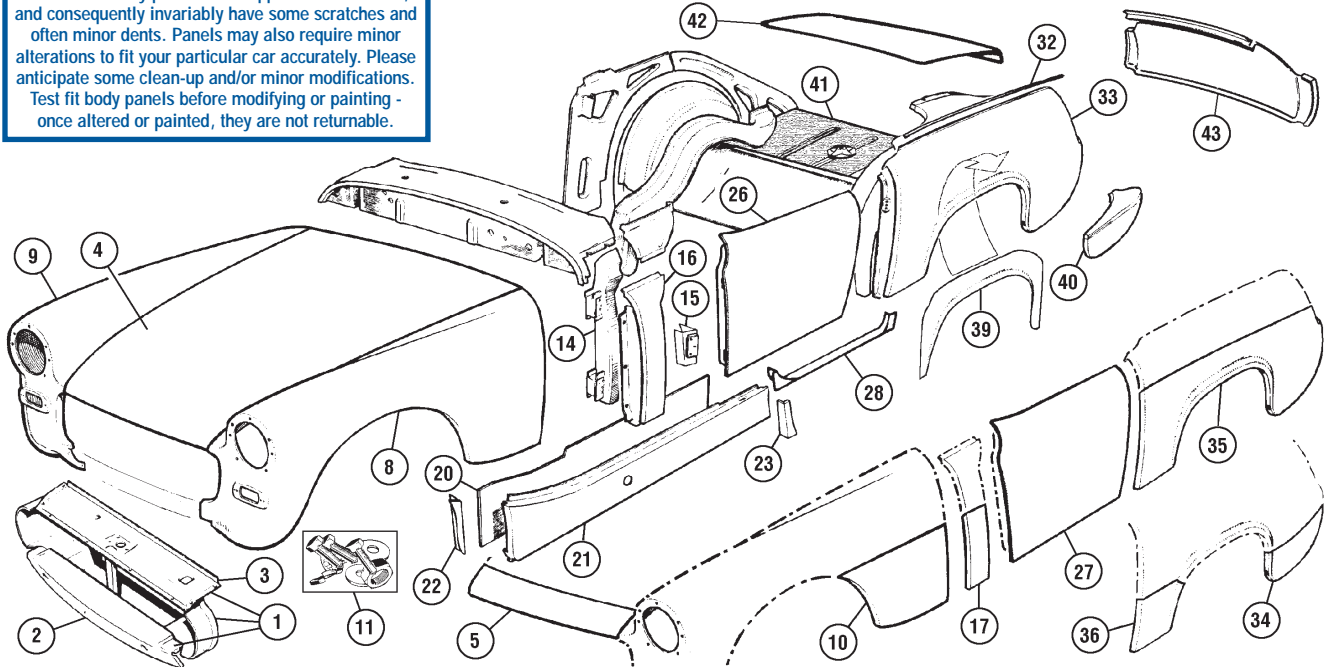

No.	Part No.	Price (each)	Description	Application	Qty. Req.
Body Panels (except Bugeye Sprite)					
1	455-145	\$348.95	FRONT PANEL ASSEMBLY	except 1500	1
	455-155	\$383.95	FRONT PANEL ASSEMBLY	1500	1
2	455-190	\$189.95	VALANCE PANEL, front	except 1500	1
	452-430	\$192.95	VALANCE PANEL, front	1500	1
3	455-165	\$83.95	HOOD LATCH PANEL	except 1500	1
	455-345	\$105.95	HOOD LATCH PANEL	1500	1
4	455-290	\$809.95	HOOD (Has provision for all hood stay configurations)	Midget to (c)183739 all Sprite	1
	455-790	\$736.95	HOOD	Midget from (c)183740	1
5	455-200	NA	REPAIR PANEL, hood "skin"	} all	1
	452-240	\$32.95	REPAIR PANEL, inner hood		1
8	455-710	\$741.95	FRONT FENDER, L/H	} AH MkII thru 1969	1
9	455-715	\$741.95	FRONT FENDER, R/H		} MG MkI thru 1969
	455-720	\$648.95	FRONT FENDER, L/H	} 1275 from '70-'74	
	455-725	\$648.95	FRONT FENDER, R/H		} 1500
	455-730	\$685.95	FRONT FENDER, L/H	1	
	455-735	\$685.95	FRONT FENDER, R/H	1	
10	455-265	\$35.95	REPAIR PANEL, L/H	} except 1500	1
	455-260	\$35.95	REPAIR PANEL, R/H		1
	455-275	\$34.95	REPAIR PANEL, L/H	} 1500	1
	455-270	\$34.95	REPAIR PANEL, R/H		1
11	322-995	\$7.30	HARDWARE KIT, ft. fender mounting		2
14	452-130	\$69.95	"A" POST ASSEMBLY, L/H	} thru 1968	1
	452-135	\$69.95	"A" POST ASSEMBLY, R/H		1
	455-185	\$50.95	"A" POST ASSEMBLY, L/H	} from 1969 on	1
	455-195	\$50.95	"A" POST ASSEMBLY, R/H		1
15	455-065	\$22.95	TAPPING PLATE ASS'Y., lower, L/H		1
	455-055	\$22.95	TAPPING PLATE ASS'Y., lower, R/H		1
16	452-645	\$37.95	OUTER SKIN, "A" post, L/H	} side curtain cars	1
	452-655	\$37.95	OUTER SKIN, "A" post, R/H		1
	455-665	\$39.95	OUTER SKIN, "A" post, L/H	} wind-up window cars	1
	455-675	\$39.95	OUTER SKIN, "A" post, R/H		1
17	455-280	\$6.95	REPAIR PANEL, lower 7 1/2"		2
20	455-445	\$32.95	INNER SILL, L/H		1
	455-440	\$32.95	INNER SILL, R/H		1
21	455-495	\$68.95	OUTER SILL, L/H, 1 jack point	} except 1500	1
	455-490	\$68.95	OUTER SILL, R/H, 1 jack point		1

455-025	\$69.95	OUTER SILL, L/H, 2 jack points	} 1500	1	
455-015	\$69.95	OUTER SILL, R/H, 2 jack points		1	
22	452-150	END CAP, front, L/H		1	
	452-155	END CAP, front, R/H		1	
23	452-160	END CAP, rear, L/H		1	
	452-165	END CAP, rear, R/H		1	
26	452-260	\$370.95	DOOR ASSEMBLY, L/H	} wind-up window cars	1
	452-270	NA	DOOR ASSEMBLY, R/H		1
27	452-170	\$177.95	DOOR SKIN, L/H	} side curtain cars	1
	452-175	\$177.95	DOOR SKIN, R/H		1
	452-250	\$80.95	DOOR SKIN, L/H	} wind-up window cars	1
	455-035	\$80.95	DOOR SKIN, R/H		1
28	452-180	\$33.95	REPAIR PIECE, inner door bottom, L/H	} all	1
	452-185	\$33.95	REPAIR PIECE, inner door bottom, R/H		1
32	457-990	\$18.95	FENDER BEADING, 66" length		A/R
33	455-915	\$579.95	REAR FENDER, L/H	} Sprite MkII & Midget MkI	1
	455-925	\$579.95	REAR FENDER, R/H		1
	455-945	\$525.95	REAR FENDER, L/H	} Sprite MkIII & Midget MkII	1
	455-955	NA	REAR FENDER, R/H		1
	455-795	\$399.95	REAR FENDER, L/H	} 1275 square arch to January 1972	1
	455-750	\$399.95	REAR FENDER, R/H		1
	455-765	\$403.95	REAR FENDER, L/H	} 1275 round arch	1
	455-760	\$403.95	REAR FENDER, R/H		} GAN5-105501 to 123730
	455-775	NA	REAR FENDER, L/H	} 1275 square arch	
	455-770	NA	REAR FENDER, R/H		} GAN5-123730 to 153290
	455-785	\$395.95	REAR FENDER, L/H	} 1500	
	455-780	\$395.95	REAR FENDER, R/H		1
34	455-705	\$46.95	REPAIR PANEL, rear of L/H fender		1
	455-695	\$46.95	REPAIR PANEL, rear of R/H fender		1
35	455-115	\$203.95	REPAIR PANEL, L/H rear wheel arch	} (square arch only)	1
	455-105	\$203.95	REPAIR PANEL, R/H rear wheel arch		1
36	455-135	\$21.95	REPAIR PANEL, L/H		1
	455-125	\$21.95	REPAIR PANEL, R/H		1
39	455-095	\$60.95	REPAIR PANEL, L/H inner wheel arch	} (square arch only)	1
	455-085	\$60.95	REPAIR PANEL, R/H inner wheel arch		1
40	455-805	\$36.95	CLOSING PANEL, trunk to fender, L/H		1
	455-815	\$36.95	CLOSING PANEL, trunk to fender, R/H		1
41	452-195	\$250.95	TRUNK FLOOR		1
42	455-895	\$342.95	TRUNK LID	1968-on	1
43	455-995	\$146.95	REAR APRON PANEL	1961-'69	1
	456-505	\$137.95	REAR APRON PANEL	1970-'74	1
	455-395	NA	REAR APRON PANEL	1500	1

LOCAL & OVERSEAS: 805-681-3400
 FAX: 805-692-2525 www.mossmotors.com



Inner Body Panels

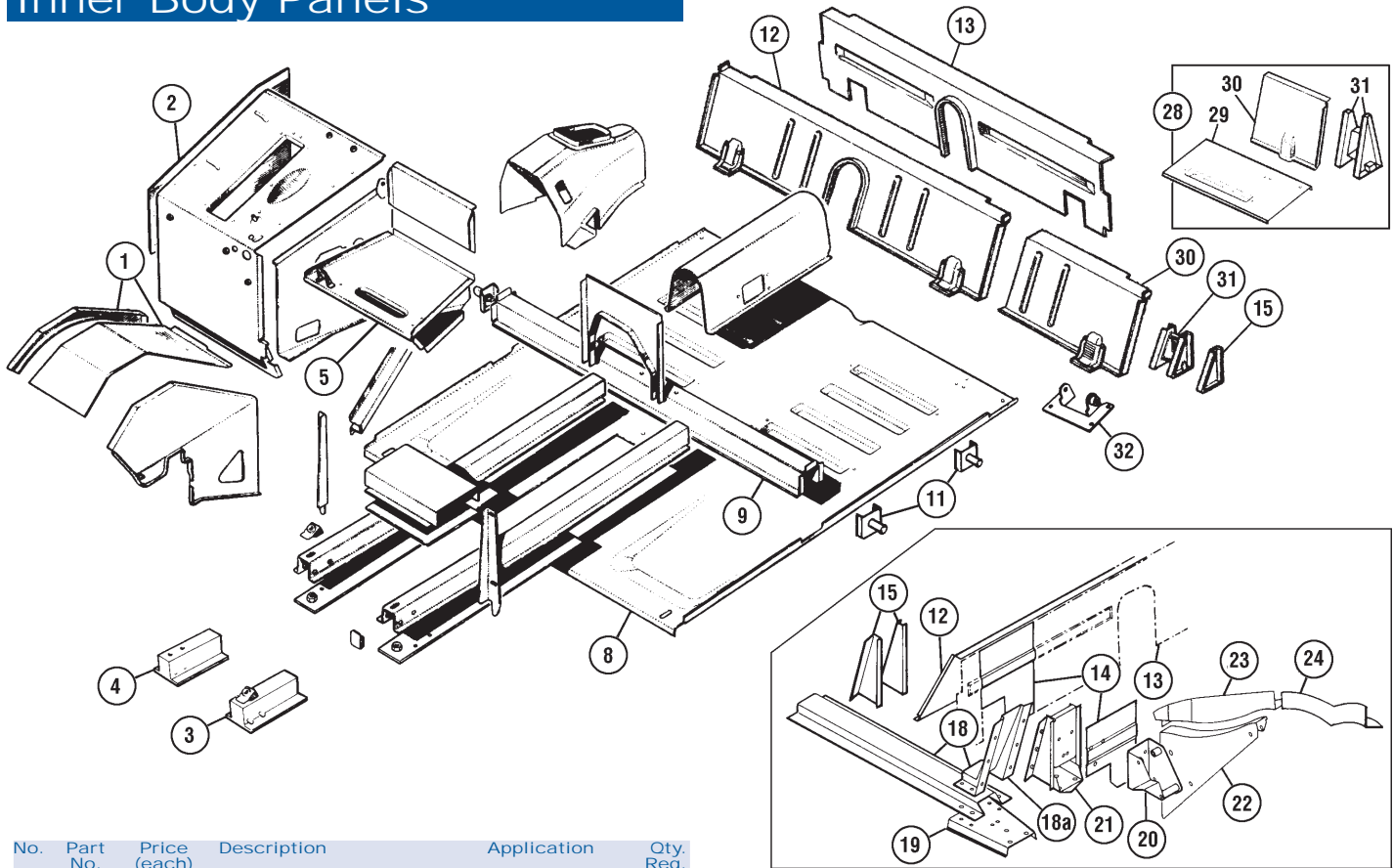

No.	Part No.	Price (each)	Description	Application	Qty. Req.
-----	----------	--------------	-------------	-------------	-----------

Internal Body Panels

1	455-225	\$50.95	WHEEL ARCH, front, R/H (as illus.)	} Bugeye	1
	455-235	\$50.95	WHEEL ARCH, front, L/H (as illus.)		1
	455-245	\$69.95	WHEEL ARCH, front, R/H (as illus.)	} except Bugeye	1
	455-255	NA	WHEEL ARCH, front, L/H (as illus.)		1
2	455-210	\$33.95	PANEL, outer side of footwell, R/H		1
	455-215	\$33.95	PANEL, outer side of footwell, L/H		1
3	455-505	\$47.95	FRAME SECTION, front, R/H	} Bugeye	1
	455-515	\$47.95	FRAME SECTION, front, L/H		1
4	455-525	\$61.95	FRAME SECTION, complete, R/H	} all except Bugeye	1
	455-535	\$61.95	FRAME SECTION, complete, L/H		1
5	455-236	\$49.95	SHELF, battery & heater	1966-'70	1
	455-237	\$49.95	SHELF, battery & heater	1971-'80	1
8	455-625	\$167.95	FLOOR PAN, R/H	} Sprite Mkl - MkII	1
	455-635	\$167.95	FLOOR PAN, L/H		1
	455-410	\$146.95	FLOOR PAN, R/H	} Sprite Mk III on	1
	455-415	\$146.95	FLOOR PAN, L/H		1
9	455-005	\$41.95	OUTER CROSS MEMBER SECTION, with jacking point, (approx. 2/5 of total crossmember length)		2
11	455-555	NA	JACKING POINT, rear L/H	} 1500 from (c)157672	2
	455-845	\$20.95	JACKING POINT, rear R/H		2
12	455-590	\$124.95	BULKHEAD, rear cockpit	Sprite Mkl & Midget Mkl, II	1
	455-645	\$65.95	BULKHEAD, rear cockpit	Sprite MkII, Midget MkIII on	1
13	455-565	\$79.95	SHUT PANEL		1
14	455-530	\$51.95	REPAIR PIECE, shut panel end		2
15	455-660	\$24.95	REINFORCEMENT PAIR, between # 12 & 13.		A/R
18	455-520†	\$69.95	REINFORCEMENT SET, bulkhead/floor	} Sprite Mkl, II	2
18a	455-975	\$59.95	BRACE		2
19	455-580	\$56.95	BASE PLATE, spring mount	} Midget I	2
20	455-540	\$55.95	BRACKET, radius arm, R/H		1
	455-550	\$55.95	BRACKET, radius arm, L/H	1/4 elliptic springs	1
21	455-500†	\$99.95	SPRING HANGER BOX	Bugeye	2
	455-510	\$96.95	SPRING HANGER BOX	Sprite MkII, Midget Mkl	2

No.	Part No.	Price (each)	Description	Application	Qty. Req.
-----	----------	--------------	-------------	-------------	-----------

22	455-560	\$30.95	DAMPER MOUNTING BRACKET, R/H	} Sprite Mkl, II	1
	455-566	\$32.95	DAMPER MOUNTING BRACKET, L/H		1
	455-570	\$32.95	DAMPER MOUNTING BRACKET, L/H	} Sprite Mk III on	1
	455-576	\$32.95	DAMPER MOUNTING BRACKET, R/H		1
23	455-600	NA	REPAIR PANEL, wheel well, R/H		1
	455-610	NA	REPAIR PANEL, wheel well, L/H		1
24	455-620	NA	REPAIR PANEL, wheel well, R/H		1
	455-630	NA	REPAIR PANEL, wheel well, L/H		1
28	455-575	NA	REPAIR ASS'Y., spring hanger, R/H	} Sprite MkII on	1
	455-585	NA	REPAIR ASS'Y., spring hanger, L/H		1
			(welded ass'y. of illus. #29, 30 & 31)	} Midget MkII on, 1/2 elliptic springs	
29	455-465	NA	REPAIR PANEL, rear floor, L/H	} Sprite Mkl - MkII	1
	455-475	\$15.75	REPAIR PANEL, rear floor, R/H		1
	455-425	\$20.95	REPAIR PANEL, rear floor, L/H	} Sprite MkIII - on	1
	455-420	\$20.95	REPAIR PANEL, rear floor, R/H		1
30	455-435	\$27.95	BULKHEAD REPAIR PANEL, L/H	} Midget MkII - on	1
	455-205	\$27.95	BULKHEAD REPAIR PANEL, R/H		1
31	455-605	\$60.95	SPRING HANGER BOX	1/2 elliptic springs	2
32	455-615	\$26.95	SPRING MOUNTING PLATE		2

† These parts are designed to be bolted together as sets prior to welding, making proper alignment easier. However, they are not meant to be bolted without being welded.

Finnigan's Waxoyl

Your best defense against rust is Waxoyl, a thick waxy fluid saturated with a powerful rust inhibitor developed for the damp English climate. Starter kit includes a 2.5 liter can of Waxoyl, pump, and sprayer.

Starter Kit 225-360 \$76.95
2.5 liter refill 225-365 \$40.95
5 liter refill 225-370 \$57.95



moss

MOSS MOTORS, LTD. TOLL-FREE ORDERS 1-800-667-7872

Windshields

Sprite Mkl & MkII, Midget Mkl

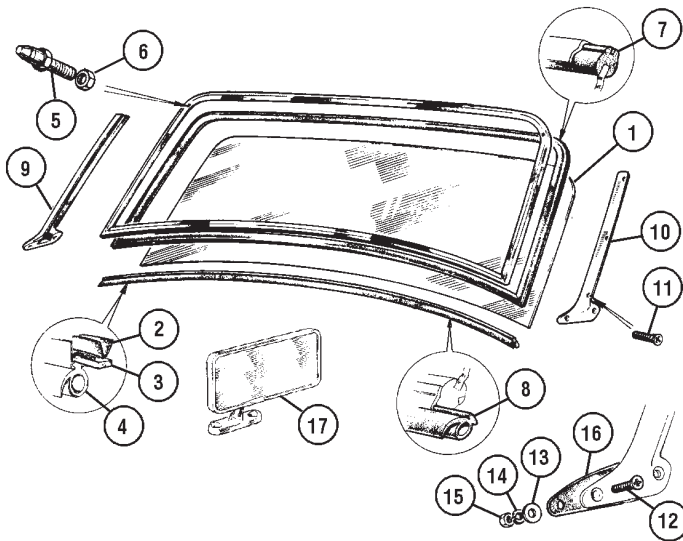

Early Bugeye windshield frames to (c)5476 had 9 Lift-the Dot studs across the top rail. Later frames had two, one at each corner. The threaded shanks on the later studs were shorter than on the early ones, and care must be used with replacement studs lest they crack the glass. Test fit before installing the glass, and shorten them if need be.
Early windshield glass measured 295mm high by 1205mm wide, while the later one measures 287mm high by 1180mm wide.

1	459-905	\$229.95	WINDSHIELD GLASS	Bugeye to (c)5476	1
	459-900	\$184.95	WINDSHIELD GLASS	{ Sprite from (c)5477 Midget Mkl	1
2	282-005	\$8.95	GLAZING RUBBER	} Bugeye to (c)5476	1
3	282-000	NA	PACKING RUBBER		1
4	680-875	\$16.95	SEAL, windshield to body		1
5	226-600	\$1.35	STUD		9
	226-600	\$1.35	STUD	} Sprite from (c)5477 Midget MKI	2
6	311-030	\$0.40	NUT		2
7	281-990	\$57.95	GLAZING RUBBER		1
	282-445	\$10.95	FILLER STRIP, glazing rubber		1
8	680-870	\$14.95	SEAL, windshield to body	1	
9	453-935	\$73.95	PILLAR, R/H	1	
10	453-940	\$73.95	PILLAR, L/H	1	
11	314-270	\$0.55	SCREW, pillar to frame		6
12	323-125	\$2.55	SCREW, pillar to body, zinc plated	(original type)	4
	323-135	\$1.95	SCREW, pillar to body, chromed	(optional)	4
13	324-155	\$0.35	WASHER, flat		4
14	365-730	\$0.20	SPRING WASHER		4
15	310-140	\$0.30	NUT		4
16	680-880	\$13.35	PAD SET, pillar to body (pair)		1
17	165-280	\$43.95	MIRROR, interior		1

SPRITE-MIDGET

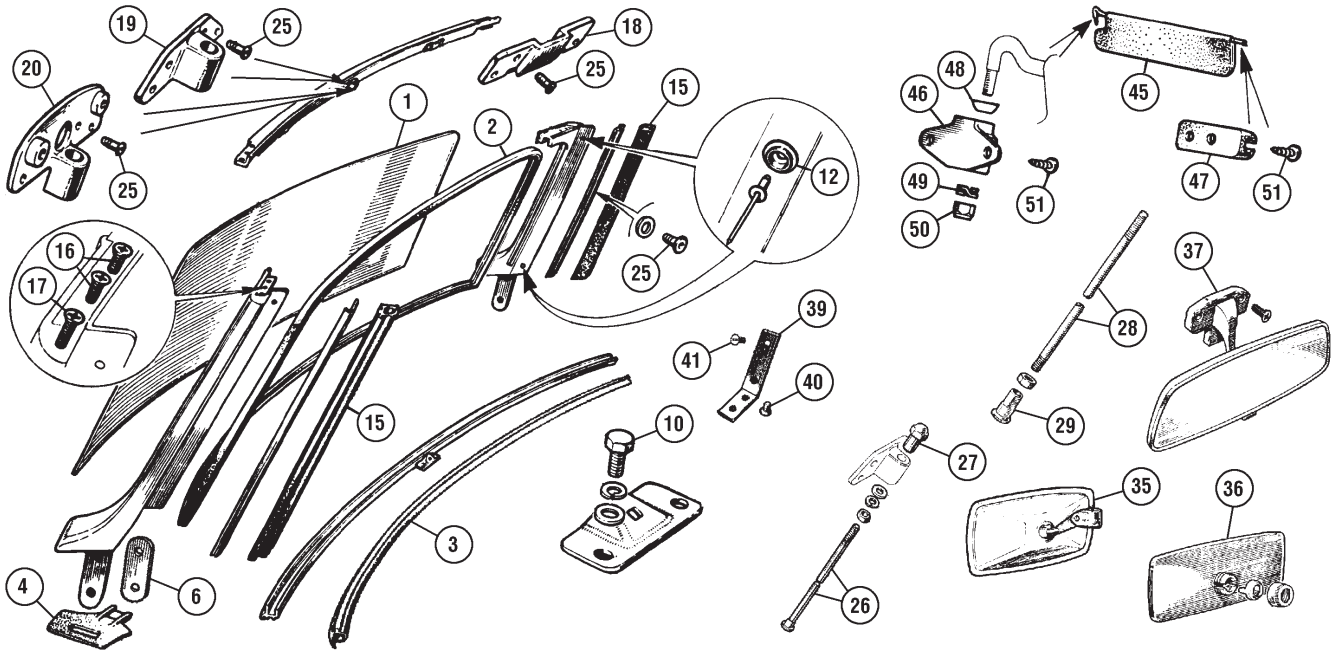

No.	Part No.	Price (each)	Description	Application	Qty. Req.
1	459-910	\$129.95	WINDSHIELD GLASS, laminated		1
2	281-995	\$30.95	GLAZING SEAL		1
3	282-025	\$19.95	SEAL, windshield to body		1
4	282-055	\$7.95	SEAL, windshield pillar to body, LH		1
	282-045	\$7.95	SEAL, windshield pillar to body, RH		1
6		NA	SHIM, pillar leg to 'A' post		A/R
10	314-275	\$1.85	BOLT, center rod bracket to body		2
12	226-720	\$0.55	STUD, top & tonneau attachment		4
15	282-210	\$5.70	SEAL, pillar to quarter light	1967-1977	2
	282-265	NA	SEAL, pillar to quarter light	1978-on	2
16	408-056	\$0.60	SCREW, top rail to pillar (inner positions)		4
17	408-057	\$0.35	SCREW, top rail to pillar (outer position)		2
18	472-620	\$13.95	BRACKET, top fastening, satin finish		2
19		NA	BRACKET, center rod, upper	1967-1969	1
20	472-415	NA	BRACKET, center rod and mirror, upper	1970-on	1
25	325-277	\$0.60	RIVET, brackets & seal retainer		34

from Sprite MkIII, Midget MkII on

26	472-435	\$5.75	CENTER ROD, chrome	} 1967-1969	1
27	472-635	\$3.10	NUT, domed		1
28	472-445	\$2.95	CENTER ROD, silver painted	} 1970-on	1
29	472-640	\$1.95	NIPPLE, lower		1
35	165-110	\$24.95	INTERIOR MIRROR, metal	{ Midget to (c)63074 Sprite to (c)74461	1
36		NA	INTERIOR MIRROR, plastic	{ Midget (c) 63075 - 75885 Sprite (c)74462-on	1
37	165-115	\$55.95	INTERIOR MIRROR	Midget (c)75886-on	1
39	400-620	NA	BRACKET SET, frame corners		1
40		NA	SCREW, bottom rail to bracket		4
41	408-055	\$0.55	SCREW, pillar to bracket		4
	233-338	NA	SUN VISOR KIT	1500 type - fits all	1
45	233-340	\$24.95	SUN VISOR, RH		1
	233-350	\$24.95	SUN VISOR, LH		1
46	233-920	\$12.95	PIVOT BRACKET, sun visor, on pillar		2
47	233-930	\$5.25	STAY BRACKET, sun visor, on top rail		2
48	324-175	\$0.55	WASHER, spherical		2
49	324-185	\$0.55	WASHER, Thackery		2
50	310-830	\$0.60	NUT, nylon		2
51	314-280	\$0.25	SCREW, alternative to orig. rivet		8

LOCAL & OVERSEAS: 805-681-3400
FAX: 805-692-2525 www.mossmotors.com



No.	Part No.	Price (each)	Description	Application	Qty. Req.
-----	----------	--------------	-------------	-------------	-----------

Grille & Badges

1	459-770	\$380.95	GRILLE		1
2	031-590	\$24.95	MEDALLION, hood		1
3	326-535	\$0.95	CLIP for medallion		3
4	031-585	\$20.95	BADGE, rear deck, gold color (as original)		1
	031-580	\$7.65	BADGE, rear deck, chromed (alternative)		1
5	326-665	\$0.30	CLIP for badge		2

Hood Fittings

10	455-835	\$45.95	HINGE		2
11	322-645	\$0.70	BOLT		8
12	324-020	\$0.20	LOCKWASHER		8
13	324-590	\$0.20	WASHER		8
14	320-225	\$0.95	BOLT, hinge pin		2
15	311-005	\$1.05	NUT, standard	} alternatives	2
	310-290	\$0.65	NUT, nylon		2

20	282-105	\$17.95	SEAL, hood rear		1
21	282-110	\$4.85	BUFFER, hood		4
22	315-075	\$0.15	WASHER		8
23	372-950	\$0.55	SCREW		8
28	314-005	\$1.05	SCREW		2
29	324-990	\$0.55	WASHER		2
30	282-125	\$2.95	BUFFER, wheel arch		2
31		NA	DISTANCE TUBE		2
32	282-215	\$11.10	SPACER		2
33	324-010	\$0.15	LOCKWASHER		2
34	311-610	\$0.90	NUT		2
38	406-980	\$48.95	STAY, hood		2
39	313-010	\$4.40	BOLT, stay to hood		2
40	365-735	\$0.25	WASHER, anti-rattle		2
41	365-720	\$0.30	WASHER		2
42		NA	WASHER		2
43	310-040	\$0.15	NUT		2
44	324-010	\$0.15	LOCKWASHER		2
45	315-085	\$0.15	WASHER		2
46	322-495	\$0.45	SCREW		4
47	324-020	\$0.20	LOCKWASHER		4
48	324-590	\$0.20	WASHER		4
52	406-990	\$19.95	STAY, auxilliary		1
53		NA	CLIP		1
54	315-180	\$0.40	LOCKWASHER		1
55	365-720	\$0.30	WASHER		1
56	325-330	\$0.25	COTTER PIN		1
59	471-130	\$5.90	CLIP		1
60	314-010	\$0.35	SCREW		2
61	324-010	\$0.15	LOCKWASHER		2
62	310-040	\$0.15	NUT		2
65	401-890	\$90.95	LOCK ROD ASS'Y.		1
66	323-005	\$0.50	SCREW		4
67		NA	SCREW		1
68	324-010	\$0.15	LOCKWASHER		5
69	315-085	\$0.15	WASHER		5
73	401-870	\$36.95	HANDLE & ESCUTCHEON		1
75	401-880	\$27.95	SAFETY CATCH & BUSH		1
76	322-247	\$0.30	BOLT		1
77	324-020	\$0.20	LOCKWASHER		1
78	324-590	\$0.20	WASHER		1
79	329-880	\$4.75	SPRING		1
85	282-120	\$8.50	PEG, locating		2
86		NA	WASHER, rubber		2
87	315-095	\$0.30	WASHER		2
88	365-730	\$0.20	LOCKWASHER		2
89	310-140	\$0.30	NUT		2
91	400-650	\$27.95	BRACKET, hood lock, R/H		1
	400-660	\$27.95	BRACKET, hood lock, L/H		1
92	457-990	\$18.95	FENDER BEADING (supplied in straight 66" length)	A/R	1
93	400-665	\$8.35	BRACKET, prop rod		1
95	322-645	\$0.70	BOLT	A/R	1
96	310-760	\$0.55	NUT	A/R	1
97	324-020	\$0.20	LOCKWASHER	A/R	1
98	324-590	\$0.20	WASHER	A/R	1

Body Fittings, Bugeye

No.	Part No.	Price (each)	Description	Application	Qty. Req.
-----	----------	--------------	-------------	-------------	-----------

Front Bumper

100	400-170	\$389.95	BUMPER BAR, front		1
102	454-010	\$39.95	OVERRIDER		2
103		NA	BOLT, overrider (for repl. overriders)		2
	322-900	\$2.00	BOLT, overrider (for orig. overriders)		2
104	400-404	\$1.00	PACKING, overrider		4
105	322-900	\$2.00	BUMPER BOLT		2
106	400-300	\$1.95	PACKING PIECE		4
107	324-860	\$0.35	WASHER		4
108	324-040	\$0.25	LOCKWASHER		4
109	310-050	\$0.50	NUT		4
112	400-175	\$29.95	BUMPER BRACKET	RH Inner	1
113	400-180	\$29.95	BUMPER BRACKET	LH Inner	1
114	400-185	\$30.95	BUMPER BRACKET	RH Outer	1
115	400-190	\$30.95	BUMPER BRACKET	LH Outer	1
118	320-645	\$0.45	BOLT		4
119	324-040	\$0.25	LOCKWASHER		4
120	324-860	\$0.35	WASHER		4
125	451-285	\$19.95	LICENSE PLATE BACKING		1
126	322-645	\$0.70	SCREW		2
127	324-020	\$0.20	LOCKWASHER		2
128	310-760	\$0.55	NUT		2

Rear Overriders

135	400-210	\$78.95	OVERRIDER		2
136	322-040	\$0.45	BOLT, overrider to bracket		4
140	400-220	\$5.70	BRACKET, upper		2
141	400-230	\$10.30	BRACKET, lower		2
142	455-935	\$25.95	BRACKET, inner		2
143	322-540	\$0.75	SCREW, upper		2
144	322-040	\$0.45	SCREW, lower		4
145	313-000	\$0.30	SCREW, locating		2
146	365-730	\$0.20	LOCKWASHER		12
147	365-720	\$0.30	WASHER		12
148	681-300	\$0.95	PAD, rubber		2

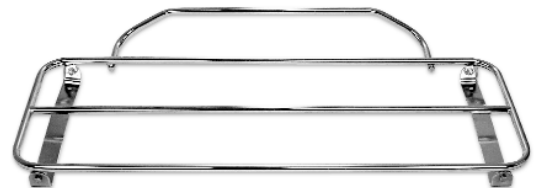

Bugeye Luggage Rack

Increase your cargo carrying capacity with this traditionally styled luggage rack. This rack mounts permanently with the included hardware and rubber mounting strips. Approx. 39" x 18".

244-720 \$379.95

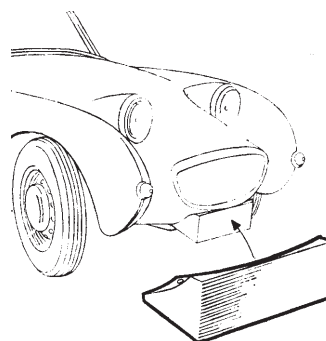

License Plate Plinth

For Bugeyes without front bumpers, this is the official factory means of mounting your number plate. (Home market cars had front bumpers as an optional accessory, so this was an important item for those cars.)

400-625 \$85.95

Front Body Fittings 1961-'80

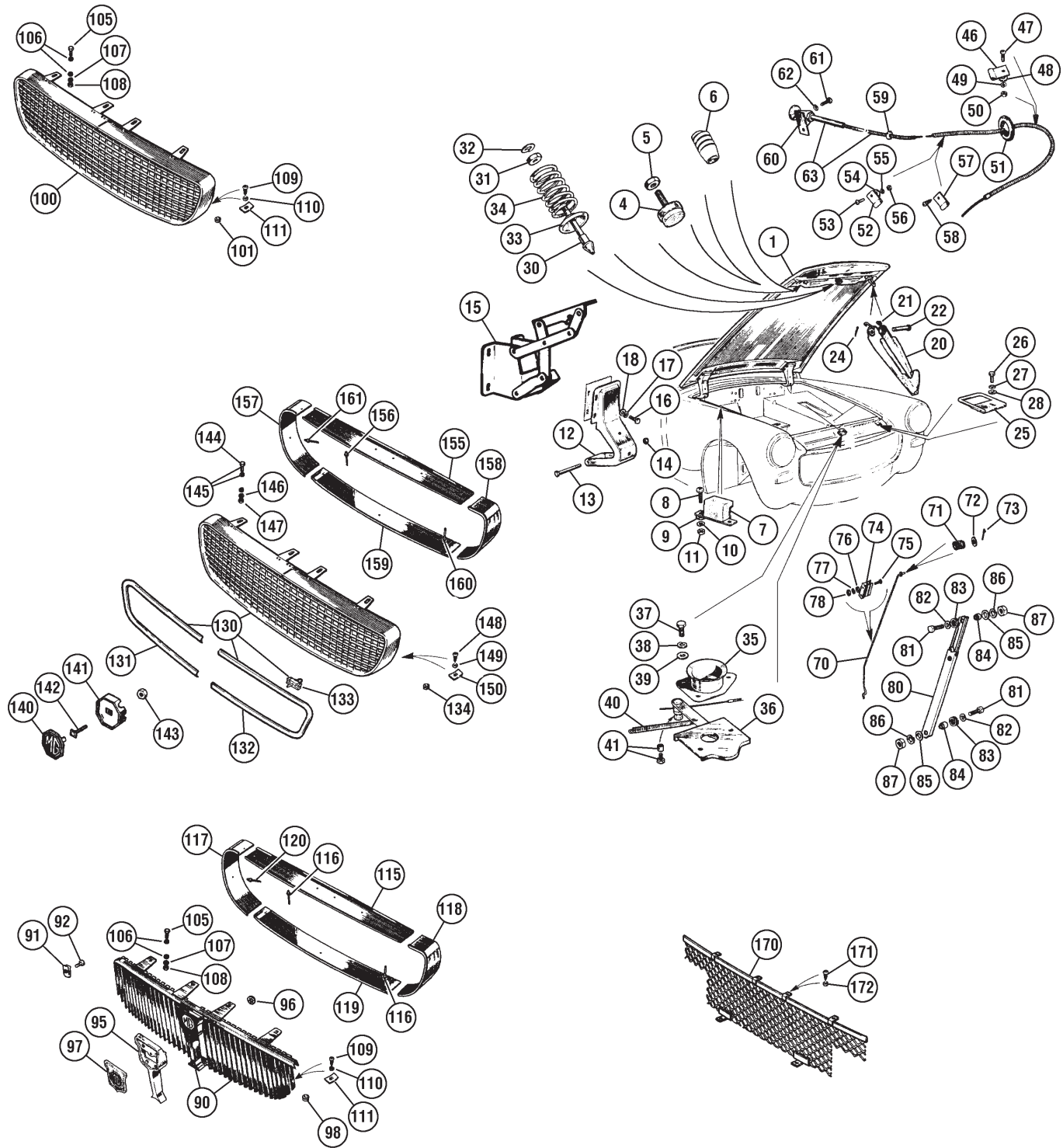

No.	Part No.	Price (each)	Description	Application	Qty. Req.
Hood					
1			HOOD ASSEMBLY	See page 43	1
4	282-130	\$4.95	BUFFER, front corner	} Midget to (c)183739 } all Sprite	2
5	848-540	\$0.45	NUT, locking		2
6	282-190	\$3.95	BUFFER, front corner	Midget from (c)183740	2
7	282-115	\$4.90	BUFFER, side		2
8	323-005	\$0.50	SCREW, buffer to fender drainage channel		4
9	315-085	\$0.15	WASHER, plain		4
10	324-010	\$0.15	WASHER, locking		4
11	310-040	\$0.15	NUT		4

No.	Part No.	Price (each)	Description	Application	Qty. Req.
12	455-835	\$45.95	HINGE, hood	} Sprite to (c)77590 } Midget to (c) 66225	2
13	320-225	\$0.95	BOLT, hinge to bulkhead		2
14	310-105	\$0.45	NUT, nyloc		2
15	455-875	NA	HINGE, hood, R/H	} from Sprite MkIV(c)77591 on } from Midget MkIII (c)66226 on	1
	455-885	NA	HINGE, hood, L/H		1
16	322-645	\$0.70	BOLT, hinge to hood	} all	8/4
17	324-020	\$0.20	WASHER, locking		8/4
18	324-590	\$0.20	WASHER, plain		8/4
20	470-640	\$25.95	HOOK, safety catch		1
21	329-325	\$4.95	SPRING, hook return		1

moss

MOSS MOTORS, LTD. TOLL-FREE ORDERS 1-800-667-7872

No.	Part No.	Price (each)	Description	Application	Qty. Req.
22		NA	CLEVIS PIN		1
24	325-005	\$0.10	SPLIT PIN		1
25	406-020	\$5.70	BRACKET, safety catch		1
26	466-385	\$0.95	SCREW, bracket to landing panel		2
27	324-010	\$0.15	WASHER, locking		2
28	315-085	\$0.15	WASHER, plain		2
30	406-000	\$8.00	PIN		1
31	310-070	\$0.45	NUT, locking pin		1
32	324-040	\$0.25	WASHER, locking		1
33	406-055	\$6.20	THIMBLE, pin		1
34	406-060	\$4.40	SPRING, bonnet lock		1
35	406-065	\$22.95	CUP, locating		1
36	406-015	\$74.95	CATCH PLATE		1
37	322-645	\$0.70	SCREW, cup and plate to landing panel		3
38	324-020	\$0.20	WASHER, locking		3
39	324-590	\$0.20	WASHER, plain		3
40	406-035	\$2.95	SPRING, catch return		1
41	406-040	\$2.30	TRUNNION & SCREW, hood release cable		1
46	182-600	\$0.95	CLIP, landing panel		1
47	323-005	\$0.50	SCREW, clip		1
48	315-085	\$0.15	WASHER, plain		1
49	324-010	\$0.15	WASHER, locking		1
50	310-040	\$0.15	NUT		1
51	680-630	\$1.00	GROMMET, mud shield		1
52	182-600	\$0.95	CLIP, LH inner wheel arch	} Midget to (c)154100 (1961-'74) all Sprite	1
53	323-005	\$0.50	SCREW, clip to wheel arch		1
54	315-085	\$0.15	WASHER, plain		1
55	324-010	\$0.15	WASHER, locking		1
56	310-040	\$0.15	NUT	1	
57	182-600	\$0.95	CLIP, bumper beam	} Midget 1500	1
58	323-705	\$0.20	SCREW, clip to bumper beam		1
59	281-050	\$4.40	GROMMET, in LH toe board	} Midget to (c)212000 (1961-'78) all Sprite	1
60		NA	BRACKET, footwell side		1
61	314-010	\$0.35	SCREW, footwell side brkt.		2
62	324-010	\$0.15	WASHER, locking		2
63	331-700	\$15.95	HOOD RELEASE CABLE, round knob	thru 1977	1
	406-005	\$8.95	HOOD RELEASE CABLE, 'T' handle	1978	1
70	406-995	NA	STAY ROD, bonnet	} Midget to (c)89500 (1961-approx.'78) all Sprite	1
71	329-165	NA	SPRING, anti rattle		1
72	365-720	\$0.30	WASHER, plain		1
73	325-330	\$0.25	COTTER PIN		1
74	471-130	\$5.90	CLIP, stay rod stowage		1
75	314-010	\$0.35	SCREW, clip to bonnet		2
76	315-085	\$0.15	WASHER, plain		2
77	324-010	\$0.15	WASHER, locking		2
78	310-040	\$0.15	NUT	2	
80	457-445	\$18.95	TELESCOPIC STAY, hood	} Midget from (c)89501 (from approx.1971)	1
81	314-265	\$0.40	BOLT		2
82	324-590	\$0.20	WASHER, plain		2
83	315-060	\$1.30	WASHER, thackery		2
84	434-370	\$1.95	SPACER		2
85	324-860	\$0.35	WASHER, plain		2
86	324-020	\$0.20	WASHER, locking		2
87	310-760	\$0.55	NUT		2
Grilles					
90	459-790	\$399.95	GRILLE ASSEMBLY	} Midget 1962-'69	1
91	326-615	\$0.55	CLIP, slat to frames		76
92	314-280	\$0.25	SCREW, slat to frames		76
95	470-635	\$92.95	PLINTH		1
96	326-530	\$0.25	CLIP, plinth to frames		2
97	201-050	\$9.30	BADGE, 'MG'		1
98		NA	GROMMET		4
100	459-780	\$279.95	GRILLE ASSEMBLY		} Sprite 1962-'69
101	472-735	\$0.45	GROMMET	4	
105	322-495	\$0.45	SCREW, grille to landing panel	} Sprite & Midget 1962-'69	4
106	324-590	\$0.20	WASHER, plain		8
107	324-020	\$0.20	WASHER, locking		4
108	310-760	\$0.55	NUT		4
109	323-705	\$0.20	SCREW, grille to front valance		2
110	315-295	\$0.25	WASHER, plain		2
111	310-355	\$0.40	SPIRE NUT		2
115	459-620	\$39.95	FINISHER, hood edge		1

Front Body Fittings 1961-'80

No.	Part No.	Price (each)	Description	Application	Qty. Req.
116	326-285	\$0.45	RIVET, hood & lower finishers	} 1962-'69	10
117	459-825	\$37.95	FINISHER, grille aperture, RH side		1
118	459-830	\$37.95	FINISHER, grille aperture, LH side		1
119	459-835	\$33.95	FINISHER, grille aperture, lower		1
120	326-285	\$0.45	RIVET, side finishers to fenders		6
130	459-800	\$399.95	GRILLE ASSEMBLY	} Midget 1970-74	1
131		NA	MOULDING, grille, RH		1
132		NA	MOULDING, grille, LH		1
133	455-330	\$0.95	CLIP, moulding to grille		8
134	472-235	NA	GROMMET		4
140	201-060	\$8.50	BADGE, 'MG'		1
141	470-675	\$43.95	PLINTH, badge		1
142		NA	STUD PLATE, plinth to grille		1
143	310-625	\$0.30	NUT		1
144	322-495	\$0.45	SCREW, grille to landing panel		4
145	324-590	\$0.20	WASHER, plain		8
146	324-020	\$0.20	WASHER, locking		4
147	310-760	\$0.55	NUT		4
148	323-705	\$0.20	SCREW, grille to valance		2
149		NA	WASHER, plain		2
150	310-355	\$0.40	SPIRE NUT		2
155	459-620	\$39.95	FINISHER, hood edge	1	
156	326-285	\$0.45	RIVET, finisher to hood	6	
157	459-840	\$29.95	FINISHER, grille aperture, RH side	1	
158	459-845	\$29.95	FINISHER, grille aperture, LH side	1	
159	459-850	\$34.95	FINISHER, grille aperture, lower	1	
160		NA	RIVET, lower finisher to valance	4	
161	326-285	\$0.45	RIVET, side finishers to fenders	6	
170	459-810	\$51.95	GRILLE ASSEMBLY	} Midget 1500	1
171	314-070	\$0.35	SCREW, grille mounting		6
172	324-990	\$0.55	WASHER, plain		6

SPRITE-MIDGET

Rear Body Fittings, 1961-'80

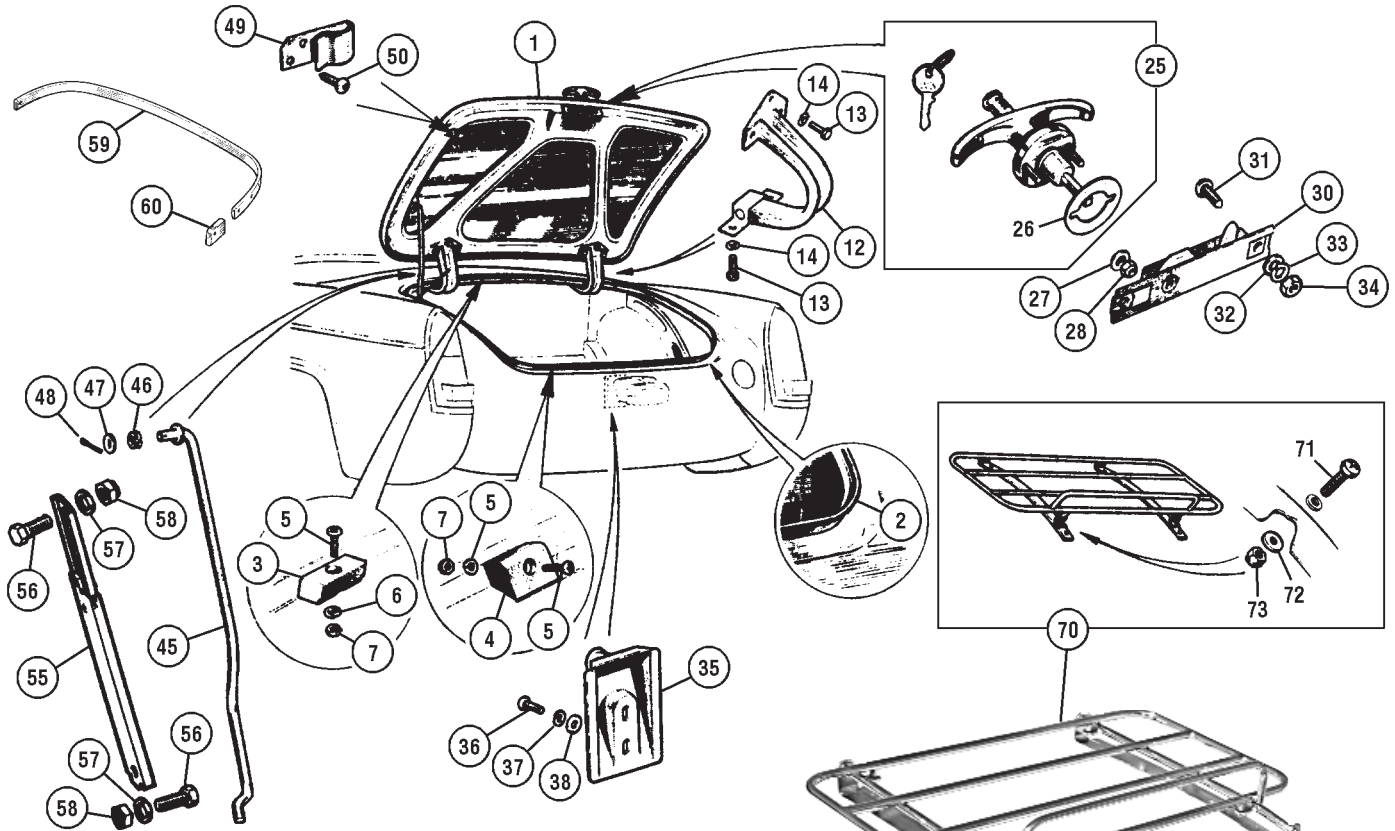

No.	Part No.	Price (each)	Description	Application	Qty. Req.
-----	----------	--------------	-------------	-------------	-----------

Trunk Fittings

1	455-895	\$342.95	TRUNK LID ASSEMBLY		1
2	282-155	\$16.95	SEAL, trunk lid		1
3	380-335	\$3.45	BUFFER, trunk lid, front		2
4	282-160	\$4.45	BUFFER, trunk lid, rear		2
5	314-290	\$0.40	SCREW, buffer to drainage channel		4
6	315-070	\$0.20	WASHER, locking		4
7	310-625	\$0.30	NUT		4
12	405-425	\$61.95	HINGE, trunk lid, RH		1
	405-430	\$61.95	HINGE, trunk lid, LH		1
13	322-645	\$0.70	BOLT, hinge to trunk lid and rear deck		10
14	324-020	\$0.20	WASHER, locking		10
25	470-445	\$31.95	HANDLE AND LOCK, trunk (with two keys)		1
26	402-525	\$0.65	GASKET, fiber		1
27	315-085	\$0.15	WASHER, plain		2
28	159-340	\$0.55	NUT, securing handle to trunk lid		2
30	470-455	\$12.95	LATCH, trunk lid		1
31	322-880	\$0.70	SCREW, latch to trunk lid		2
32	324-590	\$0.20	WASHER, plain		2
33	324-020	\$0.20	WASHER, locking		2
34	310-760	\$0.55	NUT		2
35	407-005	\$19.95	STRIKER PLATE		1
36	323-005	\$0.50	SCREW, striker plate		2
37	324-010	\$0.15	WASHER, locking		2
38	315-085	\$0.15	WASHER, plain		2
45	407-000	NA	STAY ROD, trunk lid	Midget 1500 (1960-approx. '70) all Sprite (not Bugeye)	1
46	370-460	\$1.10	WASHER, thackery		1
47	324-590	\$0.20	WASHER, plain		1
48	325-330	\$0.25	SPLIT PIN		1
49	457-475	\$7.55	CLIP, stay rod stowage		1
50	323-430	\$0.40	SCREW, clip to trunk lid		2
55	407-010	\$19.95	STAY, trunk lid, stock type	Midget from (c)89501 (from approx. 1971)	1
	406-985	\$20.95	STAY, trunk lid, self-triggering		1
56	322-645	\$0.70	BOLT, stay		2
57	324-590	\$0.20	WASHER, plain		4
58	312-000	\$0.45	NUT, nyloc		2
59	459-855	\$13.95	MOULDING, cockpit	1275 from '67-on	1
60	240-560	\$9.15	FINISHER, R/H		1
	240-565	\$9.30	FINISHER, L/H		1

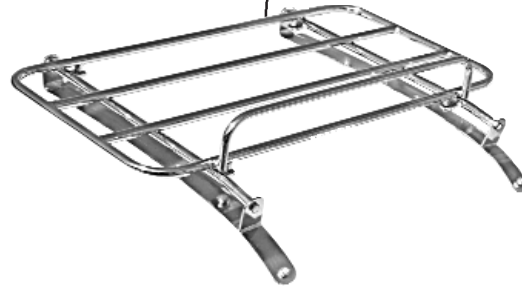

70	244-730	\$329.95	LUGGAGE RACK, stainless steel, optional	1
71	NA	NA	BOLT, rack mounting	4
72	365-720	\$0.30	WASHER, plain	4
73	310-290	\$0.65	NUT, nyloc	4

Trunk Lid Stay, Self-Triggering

This replacement for the stock stay rod makes opening and closing your trunk a one hand operation. It comes with easy to follow instructions, and all necessary hardware is available as shown in the above illustration.

406-985 \$20.95



Master Lock Set

470-458	\$72.95	MASTER LOCK SET, 3 pieces (pictured at right)
470-448	\$34.95	LOCK SET, door (2 door locks with 2 keys)
470-435	\$30.95	LOCK, R/H door with 2 keys
470-440	\$30.95	LOCK, L/H door with 2 keys



Door Lock Fitting Kit

Fits 1964-'80. Fit door locks without using the factory style securing clips, which are not easy to fit and very difficult to remove. These new clips are also designed to prevent the lock from rotating in the door skin.

402-195 \$26.95



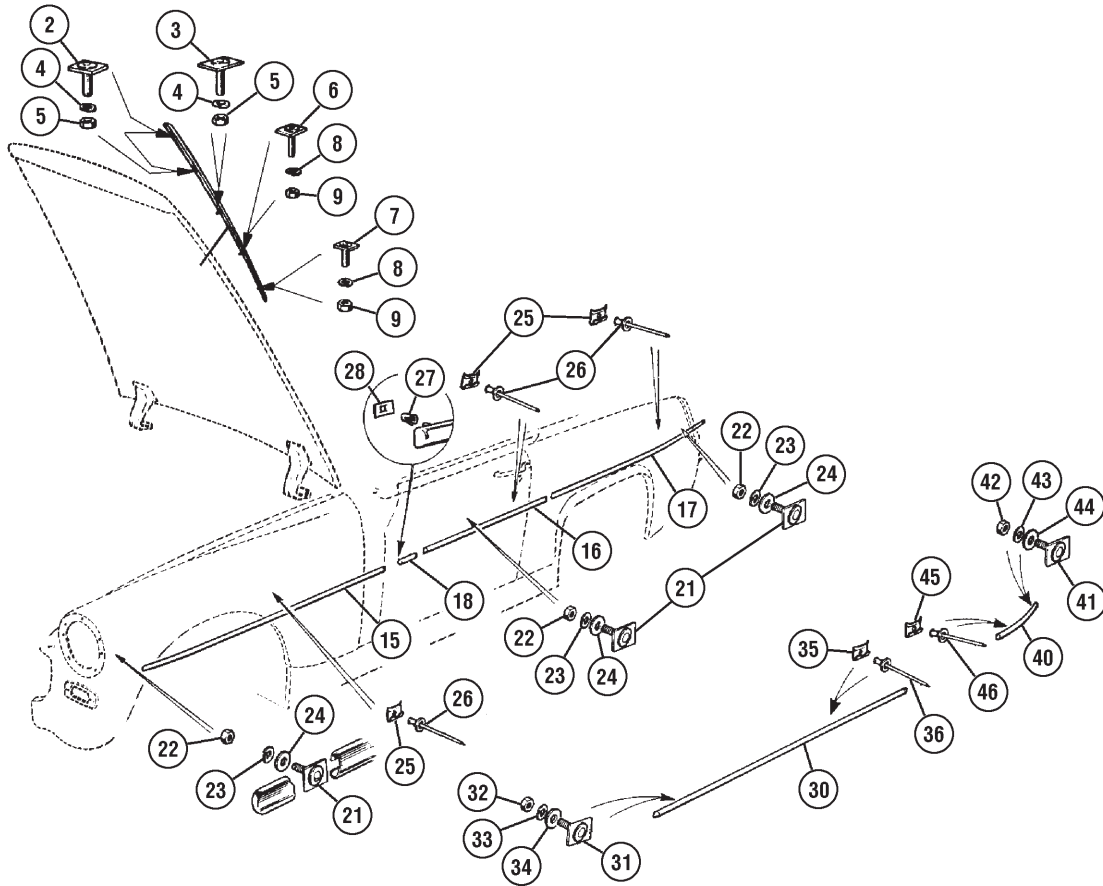

No.	Part No.	Price (each)	Description	Application	Qty. Req.
1	459-610	NA	MOULDING, hood	Midget to (c)66225 ('61-approx. '68)	1
2	326-705	\$2.90	STUD PLATE, front two positions		2
3	326-075	\$0.95	STUD PLATE, center position		1
4	324-010	\$0.15	WASHER, locking, front three positions		3
5	310-040	\$0.15	NUT, front three positions		3
6	326-725	\$3.35	STUD PLATE, second rearmost position		1
7	326-735	\$2.50	STUD PLATE, rear position		1
8	315-070	\$0.20	WASHER, locking, rear two positions		2
9	310-625	\$0.30	NUT, rear two positions		2
	459-868	NA	UPPER SIDE MOULDING SET	Midget to (c)74885 (1961-'69)	1
15	459-860	\$33.95	MOULDING, fender		2
16	459-875	\$33.95	MOULDING, door, LH		1
	459-870	\$33.95	MOULDING, door, RH		1
17	459-880	\$34.95	MOULDING, rear wing		2
18	459-865	\$39.95	MOULDING, 'A' post		2
	326-608	\$39.95	FITTING KIT, upper side mouldings		1
21	326-077	\$1.95	STUD PLATE		6
22	310-115	\$0.15	NUT, stud plate to fender & door		6
23	324-010	\$0.15	WASHER, locking		6
24	315-085	\$0.15	WASHER, plain		6
25	326-610	\$0.60	CLIP		40
26	326-295	\$0.45	RIVET, clip to fender & door		40
27	326-665	\$0.30	CLIP, front moulding lug to 'A' post	2	
28	326-510	\$0.15	SPIRE NUT, rear lug to 'A' post	2	

No.	Part No.	Price (each)	Description	Application	Qty. Req.
30	459-895	\$19.95	MOULDING, sill	Midget from (c)74886 (1970-on)	2
	326-618	NA	FITTING KIT, sill mouldings		1
31	326-077	\$1.95	STUD PLATE (front end of sill)		2
32	310-040	\$0.15	NUT, stud plate to sill		2
33	324-010	\$0.15	WASHER, locking		2
34	315-085	\$0.15	WASHER, plain	2	
35	326-610	\$0.60	CLIP, moulding to sill	Midget 1500	14
36	326-295	\$0.45	RIVET, clip to sill		14
40	459-890	\$19.95	MOULDING, rear wing, LH	Midget 1500	1
	459-885	\$19.95	MOULDING, rear wing, RH		1
41	326-077	\$1.95	STUD PLATE (rear of fender)		2
42	310-040	\$0.15	NUT, stud plate to fender		2
43	324-010	\$0.15	WASHER, locking		2
44	315-085	\$0.15	WASHER, plain		2
45	326-610	\$0.60	CLIP, moulding to fender	6	
46	326-295	\$0.45	RIVET, clip to fender	6	

Plugs & Grommets

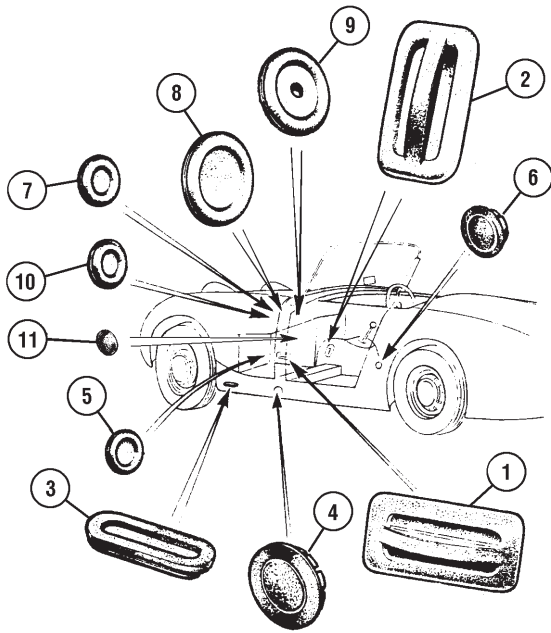

No.	Part No.	Price (each)	Description	Application	Qty. Req.
Bugeye					
1	680-940	\$1.95	PLUG, RH Toe Box Side	} Bugeye	1
2	680-940	\$1.95	PLUG, gearbox filler		1
3	282-235	\$2.35	PLUG, sill & sling point		A/R
4	282-135	\$2.95	PLUG, jack hole		2
5	282-960	\$0.95	PLUG, steering column blanking		1
6	282-150	\$1.95	PLUG, driveshaft inspection		1
7	682-075	\$1.95	PLUG, LH footwell		1
8	NA		PLUG, blanking		1
9	682-095	\$3.15	GROMMET, main wiring harness		1
10	240-515	\$1.95	GROMMET, wiper rack		1
11	282-140	\$1.25	PLUG, hinge holes (in door)		8

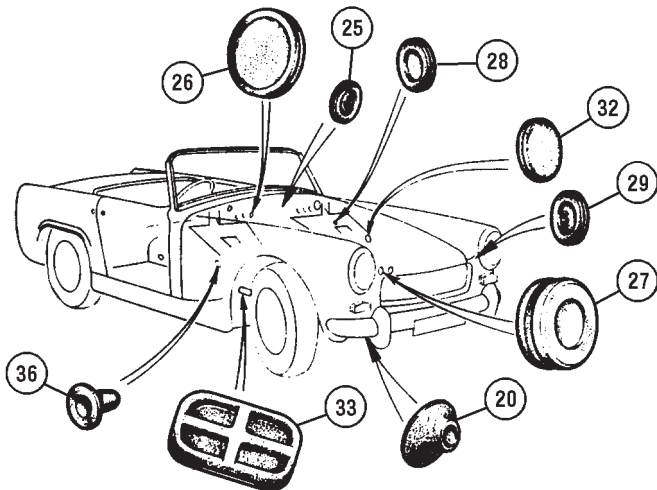

No.	Part No.	Price (each)	Description	Application	Qty. Req.
Non-Bugeye					
20	280-690	\$1.95	GROMMET, bumper bracket		2
21	282-135	\$2.95	PLUG, jacking point	qty. increased in 1975	2/4
22	280-105	\$6.80	GROMMET, fuel filler tube		1
23	282-385	\$0.95	GROMMET, no. plate lamp harnesses		2
24	282-960	\$0.95	PLUG, steering column hole	passenger's side	1
25	282-395	\$2.10	GROMMET, washer tube		1
	682-480	\$0.95	GROMMET, speedometer cable		1
	282-997	\$1.30	GROMMET, oil pressure pipe	} 1961-'77	1
	240-515	\$1.95	GROMMET, temp. gauge tube		1
26	282-385	\$0.95	GROMMET, heater/air cable	if heater is fitted	1
	282-925	\$1.10	PLUG, heater cable hole	if heater not fitted	1
	282-385	\$0.95	GROMMET, choke cable through bulkhead		1
	240-515	\$1.95	GROMMET, wiper rack through bulkhead		1
	682-095	\$3.15	GROMMET, main harness in bulkhead		1
	682-480	\$0.95	GROMMET, wiper harness in bulkhead		1
	682-480	\$0.95	GROMMET, dip switch harness in footwell	1961-'69	1
27	282-975	\$1.95	GROMMET, oil cooler hole in mudshield		2
28	281-050	\$4.40	PLUG, wheel arch panel		2
29	282-425	\$2.10	GROMMET, front lamp wires		3
	680-630	\$1.00	GROMMET, hood cable in ft. panel		1
	281-050	\$4.40	GROMMET, hood cable, toe board	1961-'78	1
30	282-150	\$1.95	PLUG, propshaft lubricating hole		1
31	282-235	\$2.35	PLUG, front floor pan		2
32	682-075	\$1.95	PLUG, LH footwell side	(if fitted)	2
33	NA		PLUG, slave cyl. access hole (Not available. Use #34 as replacement.)	} 1961-'76	1
34	680-940	\$1.95	PLUG, gearbox filler hole		1
35	NA		PLUG, demister outlet, footwell side	if heater not fitted	2
36	282-495	\$0.35	PLUG, 'top hat', footwell side		2
37	281-050	\$4.40	GROMMET, fuel pump breather	} 1961-'74	1
	565-050	\$1.00	GROMMET, fuel pump breather		1
	282-385	\$0.95	GROMMET, fuel tank sender harness		1

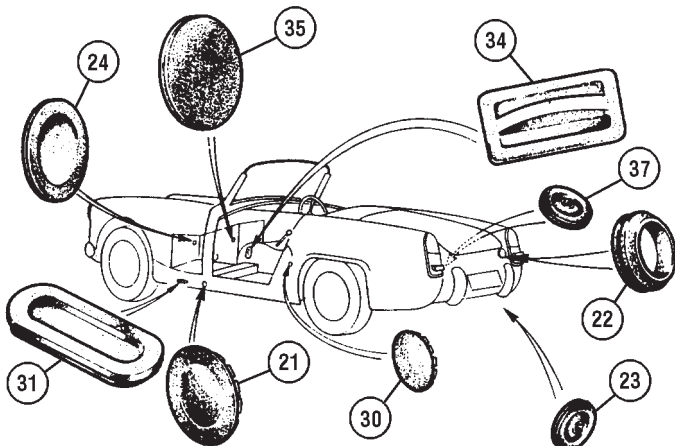

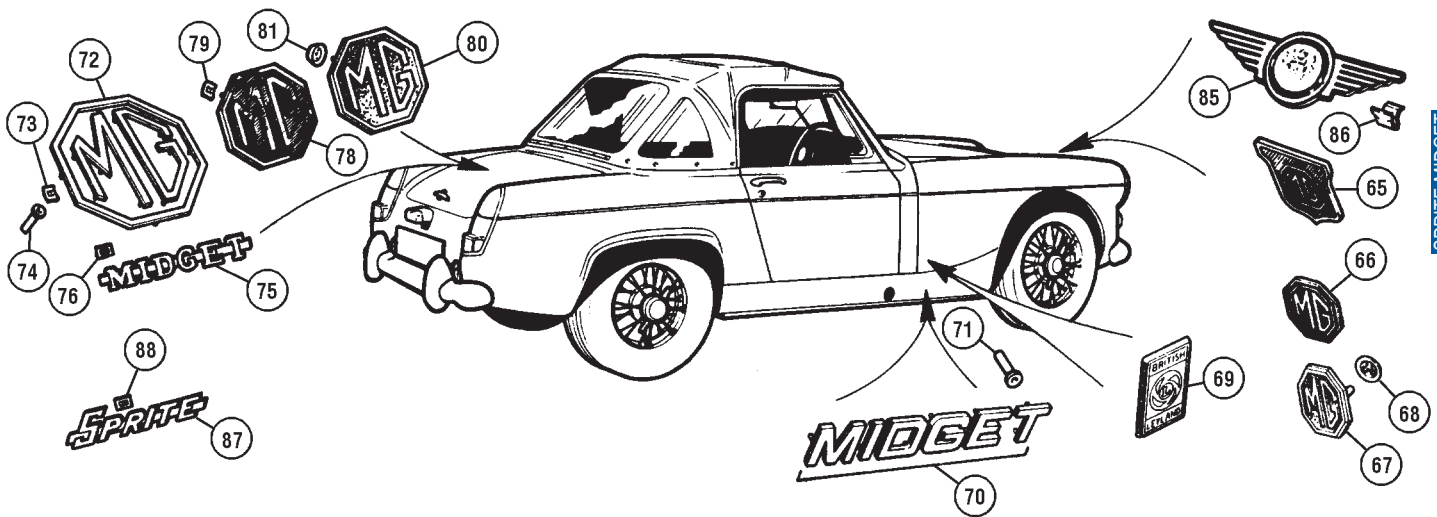

SPRITE-MIDGET

No.	Part No.	Price (each)	Description	Application	Qty. Req.
Midget Badges					
65	201-050	\$9.30	GRILLE BADGE, 'MG'	1961-'69	1
66	201-060	\$8.50	GRILLE BADGE, 'MG'	1970-'74	1
67	475-165	\$16.95	BUMPER BADGE, 'MG'	} 1975-'80	1
68	326-530	\$0.25	CLIP, badge to bumper		2
69	470-685	\$9.95	BADGE, "British Leyland"	} 1970-on	2
70	470-605	\$22.95	SILL LETTER SET, 'Midget'		2
71	326-650	\$0.60	CLIP		24
72	470-698	\$10.95	TRUNK BADGE SET, 'MG'	} 1961-'69	1
73	326-500	\$0.15	SPIRE NUT		13
74	326-650	\$0.60	CLIP, alternative		13
75	470-625	\$8.95	TRUNK BADGE, 'Midget'		1
76	326-510	\$0.15	SPIRE NUT		2
78	470-665	\$16.95	TRUNK BADGE, plastic, 'MG'	} 1970-1976 to (c)171430	1
79	326-530	\$0.25	SPIRE NUT		3
80	470-690	\$30.95	TRUNK BADGE, metal, 'MG'	} 1976 from 171431-on	1
81	326-530	\$0.25	CLIP		3
Sprite Badges					
85	031-600	\$24.95	HOOD BADGE, 'Austin Healey Sprite'		1
86	326-535	\$0.95	CLIP		4
87	470-615	\$19.95	TRUNK BADGE, 'Sprite'		1
88	326-510	\$0.15	SPIRE NUT		2

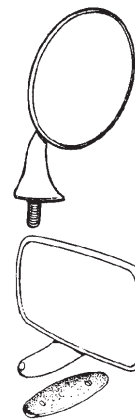

Fender Mirrors

165-400	\$14.95	FENDER MIRROR, R/H flat	1
165-500	\$14.95	FENDER MIRROR, L/H flat	1
165-210	\$14.95	FENDER MIRROR, R/H convex	1
165-300	\$14.95	FENDER MIRROR, L/H convex	1

Door Mirrors

165-170	\$37.95	DOOR MIRROR, R/H flat, stainless	1
165-135	\$37.95	DOOR MIRROR, L/H flat, stainless	1
165-195	\$36.95	DOOR MIRROR, R/H flat, black	1
165-190	\$36.95	DOOR MIRROR, L/H flat, black	1
165-185	\$39.95	DOOR MIRROR, R/H convex, stainless	1
165-180	\$39.95	DOOR MIRROR, L/H convex, stainless	1
165-630	\$18.95	BASE KIT (chrome plinth)	A/R
165-638	\$6.25	MOUNTING KIT (pad & screws)	A/R

Door Windows

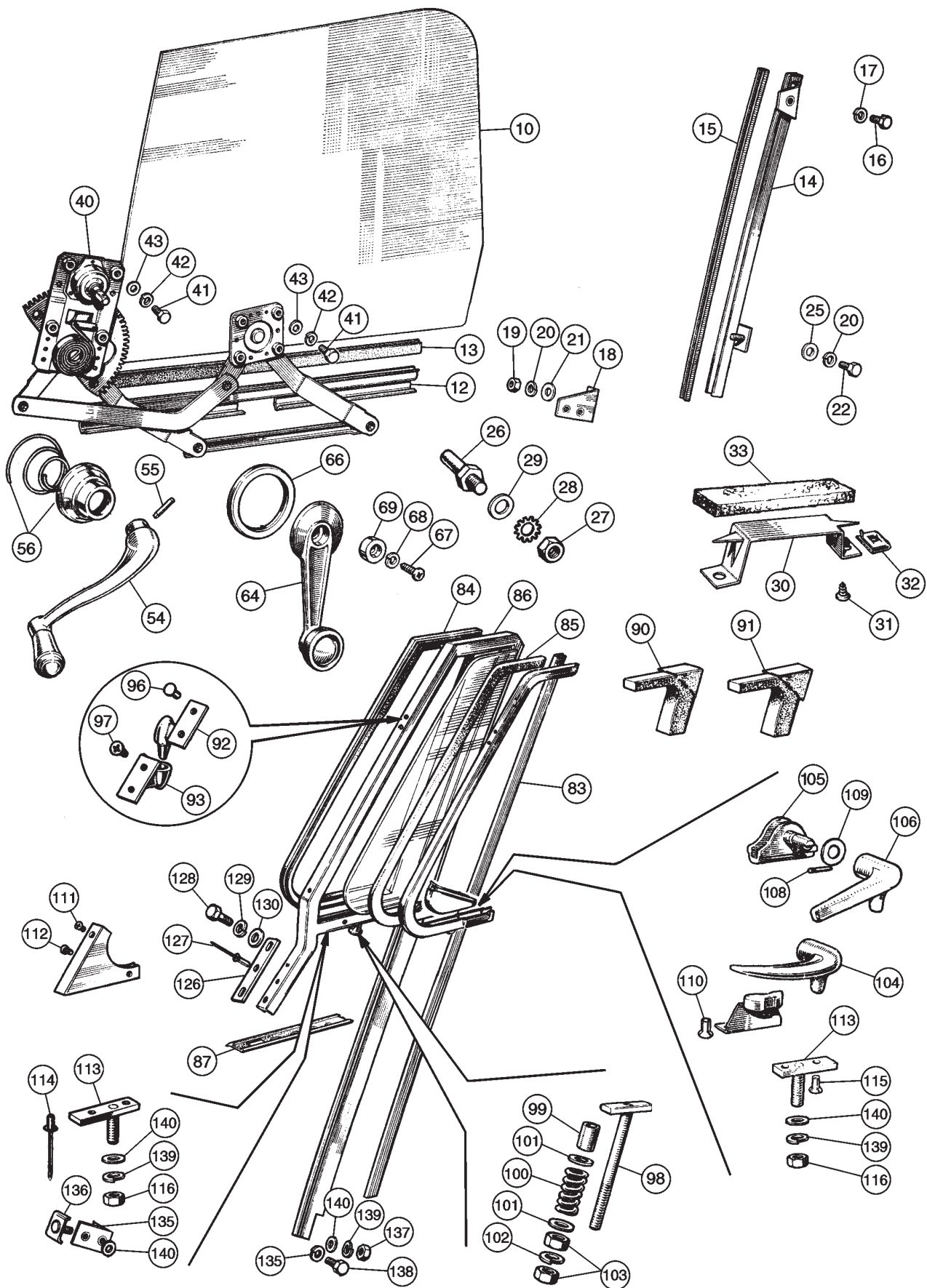

Door Windows

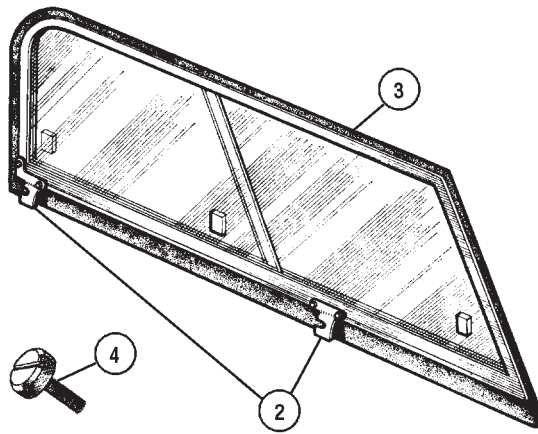

No.	Part No.	Price (each)	Description	Application	Qty. Req.
-----	----------	--------------	-------------	-------------	-----------

Sidecurtains

	259-678	\$459.95	SIDECURTAIN SET, complete		1
2	259-675	\$38.95	BRACKET SET, with nuts & bolts		1
3	282-455	\$26.95	SEAL, L/H		1
	282-465	\$26.95	SEAL, R/H		1
4	401-690	\$8.25	SCREW, sidecurtain mounting	Bugeye	4
	401-700	\$10.95	SCREW, sidecurtain mounting	non-Bugeye	4

Our U.K.-made aluminum sidecurtains are close reproductions of the original units fitted to all except the earliest Bugeyes, which used a primitive fabric covered design. Our sidecurtains fit all.

No.	Part No.	Price (each)	Description	Application	Qty. Req.
-----	----------	--------------	-------------	-------------	-----------

Door Windows

10	459-920	\$119.95	DOOR GLASS, RH		1
	459-925	\$119.95	DOOR GLASS, LH		1
12	407-025	\$26.95	CHANNEL, lower		2
13	680-667	\$2.45	GLAZING STRIP, sold per foot	Cut to 18 3/8" long.	A/R
14	407-014	\$32.95	CHANNEL, rear, RH		1
	407-019	\$32.95	CHANNEL, rear, LH		1
15	458-610	\$4.75	GLAZING STRIP, felt and rubber		2
16	322-170	\$0.35	SCREW, channel top to door		2
17	324-020	\$0.20	LOCKWASHER		2
18		NA	BRACKET, channel bottom to door, RH		1
		NA	BRACKET, channel bottom to door, LH		1
19	310-760	\$0.55	NUT, bracket to channel bottom		2
20	324-020	\$0.20	LOCKWASHER		6
21	324-590	\$0.20	WASHER, plain		2
22	322-170	\$0.35	SCREW, bracket to door		4
25	324-590	\$0.20	WASHER, plain		4
26		NA	STOP, regulator		2
27	310-140	\$0.30	NUT, stop to door		2
28	315-300	\$0.40	WASHER, shakeproof		2
29	365-720	\$0.30	WASHER, plain		2
30		NA	STOP, lower		2
31	323-705	\$0.20	SCREW, lower stop to door bottom		4
32		NA	SPIRE NUT		4
33	402-230	\$3.40	FELT PAD, lower stop		2
40	402-295	NA	REGULATOR, window, RH	Midget to (c)60459	1
	402-290	NA	REGULATOR, window, LH	Sprite to (c)72040	1
	405-535	NA	REGULATOR, window, RH	Midget (c)60460-on	1
	405-530	NA	REGULATOR, window, LH	Sprite (c)72041-on	1
41	322-170	\$0.35	SCREW, regulator to door		16
42	324-020	\$0.20	WASHER, locking		16
43	324-115	\$0.45	WASHER, plain		16
54	472-110	\$15.95	HANDLE, window regulator	Midget to (c)60459	2
55	803-230	\$1.35	PIN, handle to regulator	Sprite to (c)72040	2
56	470-600	\$10.30	ESCUTCHEON AND SPRING		2
64	472-520	\$4.95	HANDLE, window regulator,	Midget (c)60460-on	2
66	472-515	\$1.95	ESCUTCHEON, handle	Sprite (c)72041-on	2

No.	Part No.	Price (each)	Description	Application	Qty. Req.
67	472-535	\$0.40	SCREW, chrome	} to 1974 approx.	2
68	324-010	\$0.15	LOCKWASHER		2
69	472-530	\$3.40	ESCUTCHEON, chrome		2
70	472-495	\$1.95	SCREW, flanged, handle to regulator	1974 on approx.	2
80	*	NA	QUARTER LIGHT ASS'Y, RH, chrome (with hooked handle)	} to G-AN4-64474; to H-AN9-75702.	1
	*	NA	QUARTER LIGHT ASS'Y, LH, chrome (with hooked handle)		1
	*	NA	QUARTER LIGHT ASS'Y, RH, chrome (with straight handle)	G-AN4-64475 on; to G-AN5-121649;	1
	*	NA	QUARTER LIGHT ASS'Y, LH, chrome (with straight handle)	H-AN9-75703 on; H-AN10; A-AN10;	1

*These early assemblies are no longer available. The later type below may be used.

82	407-030	NA	QUARTER LIGHT ASS'Y, RH, stainless steel (w/straight handle)	} Midget from (c)121650 (1973-'80)	1
	407-040	\$499.95	QUARTER LIGHT ASS'Y, LH, stainless steel (w/straight handle)		1
83	458-610	\$4.75	GLAZING STRIP, felt and rubber		2
84	282-075	\$19.95	SEAL, quarter light, RH		1
	282-085	\$19.95	SEAL, quarter light, LH		1
85	282-550	\$1.95	GLAZING RUBBER	Cut to 19" long.	2
86	459-930	\$149.95	GLASS, RH		1
	459-935	\$149.95	GLASS, LH		1
87	282-200	\$4.95	SEAL, quarter light to door, RH		1
	282-205	\$4.95	SEAL, quarter light to door, LH		1
90	282-575†	\$4.05	CORNER BLOCK	chrome ass'y. (1962-68)	2
	282-595†	\$3.95	CORNER BLOCK	chrome ass'y. (1969-'72)	2
91	282-065	\$2.50	CORNER BLOCK	stainless ass'y. (1973-'80)	2

†These two corner blocks may be interchanged.

92		NA	TOP PIVOT, upper half, RH	} chrome ass'y.	1
93		NA	TOP PIVOT, lower half, RH		1
		NA	TOP PIVOT, upper half, LH		1
		NA	TOP PIVOT, lower half, LH		1
	407-045	\$5.55	TOP PIVOT, upper half, RH	} stainless ass'y.	1
	407-050	\$6.60	TOP PIVOT, lower half, RH		1
	407-055	\$5.55	TOP PIVOT, upper half, LH		1
	407-060	\$6.60	TOP PIVOT, lower half, LH		1
96	325-095	\$0.55	RIVET, upper pivot half to frame		4
97	314-305	\$0.75	SCREW, lower pivot half to frame		4
98	407-130	NA	BOTTOM PIVOT	chrome ass'y.	2
	407-140	\$16.95	BOTTOM PIVOT	stainless ass'y.	2
99		NA	DISTANCE TUBE, bottom pivot		2
100	329-850	\$1.95	SPRING, bottom pivot		2
101	324-590	\$0.20	WASHER, plain		4
102	324-020	\$0.20	WASHER, locking		2
103	310-760	\$0.55	NUT		4
104	470-505	NA	LOCKING HANDLE, hooked, RH	} Midget to (c)64474 Sprite to (c)75702	1
	470-515	NA	LOCKING HANDLE, hooked, LH		1
105	470-425	NA	BRACKET AND PIVOT		2
	470-430	NA	BRACKET AND PIVOT		2
106	470-585	\$27.95	LOCKING HANDLE, straight, RH	} G-AN4-64475 on H-AN9-75703 on	1
	470-595	\$27.95	LOCKING HANDLE, straight, LH		1

108	325-470	\$0.95	PIN, handle to pivot		2
109	324-295	\$0.80	WASHER, waved		2
110	325-085	\$0.50	RIVET, bracket to inner frame		4
111	314-300	\$0.40	SCREW, corner finisher to frame, upper		2
112	458-550	\$0.55	SCREW, corner finisher to frame, lower		4
113	407-065	\$5.45	STUD PLATE, quarter light to door		4
114		NA	RIVET, front stud plate to frame		4
115		NA	RIVET, rear stud plate and latch to frame		4
116	312-010	\$1.70	NUT, stud plate to door		4
126		NA	SHIM, front frame foot to door, 1/16" thick		A/R
127		NA	RIVET, shim to front frame foot		2
128	322-540	\$0.75	SCREW, front frame foot to door		4
129	365-730	\$0.20	WASHER, locking		4
130		NA	WASHER, plain		4
135		NA	BRACKET, drop glass channel to door		2
136	407-075	\$0.35	STUD PLATE, bracket to drop glass channel		2
137	310-760	\$0.55	NUT, bracket to drop glass channel		2
138	322-170	\$0.35	BOLT, bracket to door		4
139	324-020	\$0.20	WASHER, locking		10
140	324-590	\$0.20	WASHER, plain		10

Bumpers

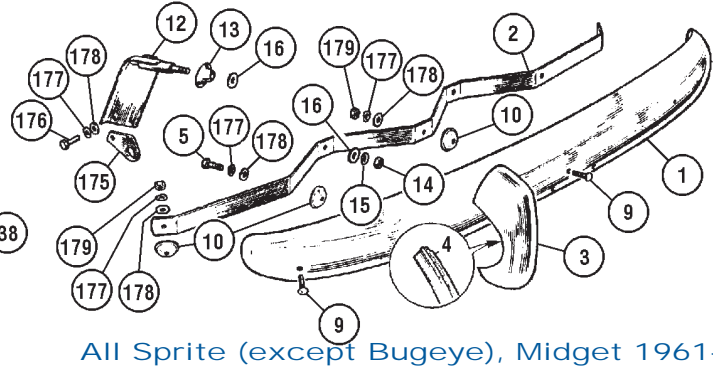
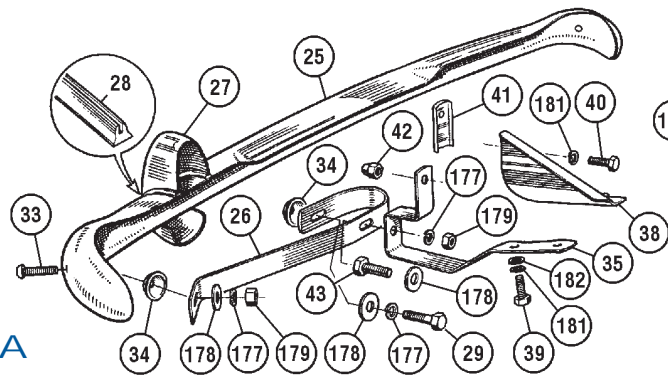

All Sprite (except Bugeye), Midget 1961-'69

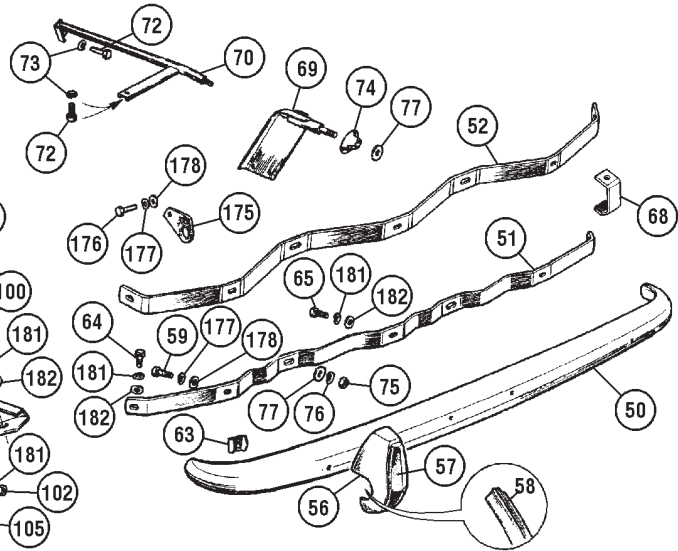
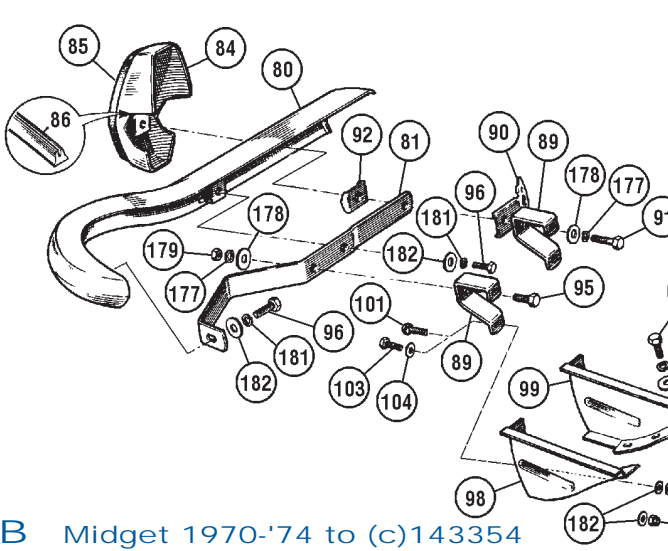

Midget 1970-'74 to (c)143354

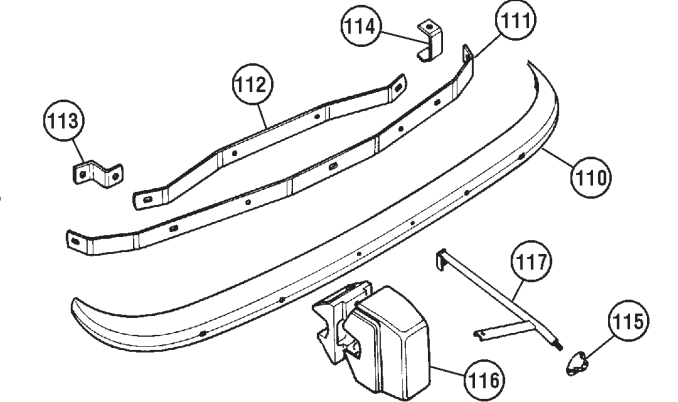
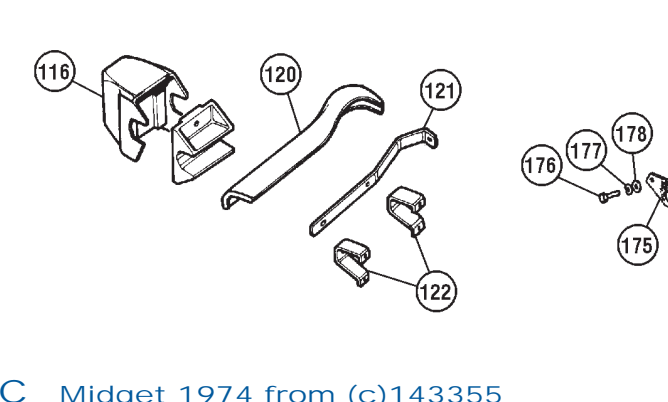

Midget 1974 from (c)143355

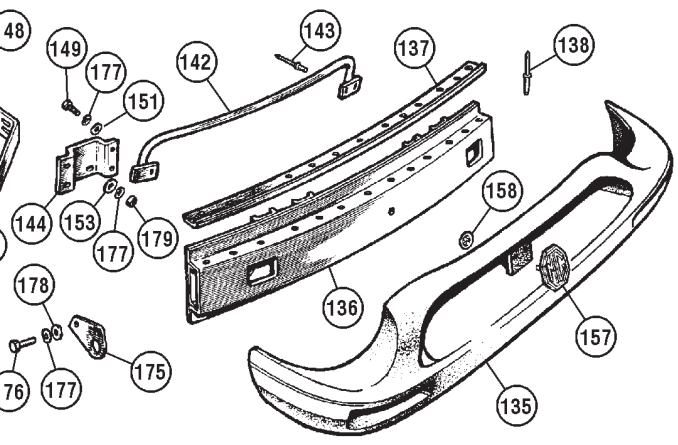
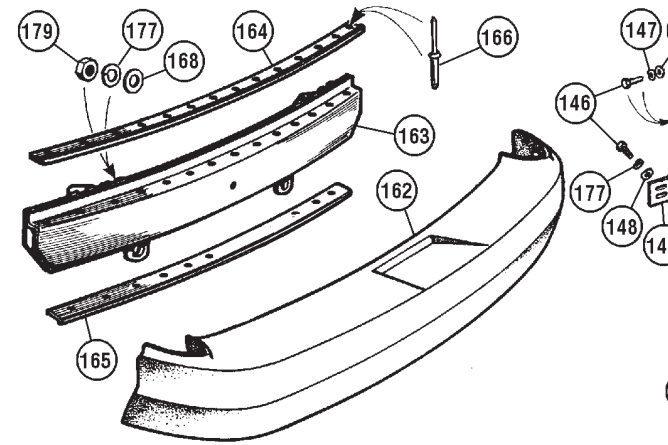

Midget 1500 1975-'80

Bumpers

No. Part No. Price (each) Description Application Qty. Req.

A - 948 (except Bugeye), 1098, 1275 to Sprite (c)85286, Midget (c)74885 (1961-'69)

1	400-240	\$149.95	BUMPER BLADE, front		1
2	400-250	\$29.95	SPRING BAR		1
3	853-110	\$33.95	OVER RIDER		2
4	400-418	\$4.70	PACKING STRIP SET, for 4 over riders		2
5	322-615	\$0.75	BOLT, over rider and blade to spring bar		1
9	322-900	\$2.00	BOLT & NUT, bumper mounting, chrome		3
10	400-315	\$1.95	PACKING PIECE, spring bar to blade		5
12	455-905	\$20.95	BRACKET, bumper to chassis, RH		1
	455-855	\$20.95	BRACKET, bumper to chassis, LH		1
13	280-690	\$1.95	GROMMET, front valance		2
14	472-347	\$0.30	NUT, spring bar to bracket		2
15	315-105	\$0.50	WASHER, locking		2
16	315-120	\$1.05	WASHER, plain		4
25	853-100	\$259.95	BUMPER BAR, rear		1
26	400-260	\$19.95	SPRING BAR		2
27	853-110	\$33.95	OVER RIDER		2
28	400-418	\$4.70	PACKING STRIP SET, for 4 over riders		1
29	322-615	\$0.75	BOLT, over rider and blade to spring bar		2
33	322-900	\$2.00	BOLT & NUT, bumper mounting, chrome		2
34	400-315	\$1.95	PACKING PIECE, spring bar to blade		4
35	400-505	\$14.95	BRACKET, bumper mounting, RH		1
	400-515	\$15.95	BRACKET, bumper mounting, LH		1
38	400-545	\$13.95	SUPPORT, mounting bracket		2
39	322-040	\$0.45	BOLT, bracket/support to boot floor		4
40	322-040	\$0.45	BOLT, bracket/support to rear valance		2
41	400-525	\$17.95	FINISHER, chrome, mounting bracket		2
42	402-550	\$2.95	DOME NUT, chrome		2
43	320-285	\$0.50	BOLT, spring bar to bracket		2

B - 1275 Midget from (c)74886 to 143354 (1970-mid'74)

50	400-270	\$169.95	BUMPER BLADE, front		1
51		NA	SPRING BAR (Not avail. - use #52) thru 1972		1
52	400-290	\$30.95	SPRING BAR	1973-'74 to (c)143354	1
56	400-310	\$39.95	OVER RIDER		2
57	400-550	\$6.95	RUBBER FACING, over rider		2
58	400-418	\$4.70	PACKING STRIP SET, for 4 over riders		1
59	320-345	\$0.75	BOLT, over rider and blade to spring bar		2
63	400-585	\$1.35	SPACER, bumper blade to spring bar		2
64	322-040	\$0.45	BOLT, outer ends of spring bar to blade		2
65	322-540	\$0.75	BOLT center of spring bar to blade		2
68	400-535	NA	REINFORCEMENT	from (c)123731 (1973+)	1
69	455-905	\$20.95	BRACKET, bumper to chassis, RH	} to (c)138000 (1970-'73)	1
	455-855	\$20.95	BRACKET, bumper to chassis, LH		1
70	400-580	NA	BRACKET, bumper to chassis, RH	} from (c)138801 (1974)	1
	400-590	NA	BRACKET, bumper to chassis, LH		1
72	322-645	\$0.70	BOLT, bracket		4
73	324-020	\$0.20	WASHER, locking		4
74	280-690	\$1.95	GROMMET, front valance		2
75	472-347	\$0.30	NUT, spring bar to bracket		2
76	315-105	\$0.50	WASHER, locking		2
77	315-120	\$1.05	WASHER, plain		4
80	400-320	\$69.95	BUMPER BAR, rear, RH		1
	400-330	\$69.95	BUMPER BAR, rear, LH		1
81	400-340	\$9.70	SPRING BAR		2
84	400-310	\$39.95	OVER RIDER		2
85	400-550	\$6.95	RUBBER FACING, over rider		2
86	400-418	\$4.70	PACKING STRIP SET, for 4 over riders		1
89	400-350	\$9.15	BRACKET, bumper mounting		4
90	400-555	\$25.95	BRACKET, number plate lamp mounting, RH		1
	400-565	\$25.95	BRACKET, number plate lamp mounting, LH		1
91	320-345	\$0.75	BOLT, over rider to mounting bracket		2
92	400-585	\$1.35	SPACER, bumper blade to spring bar		2
95	322-050	\$0.55	BOLT, spring bar to mounting bracket		2
96	322-040	\$0.45	BOLT, bumper blade to spring bar		4
98	400-600	\$9.05	SUPPORT, mounting bracket, outer RH		1
99	400-605	\$8.40	SUPPORT, mounting bracket, inner RH		1
	400-610	\$8.40	SUPPORT, mounting bracket, outer LH		1
	400-615	\$8.60	SUPPORT, mounting bracket, inner LH		1
100	322-040	\$0.45	BOLT, support to trunk floor		12

101	321-708	\$2.45	BOLT & NUT, mounting bracket	} to (c)138800 (1970-'73)	8
102	310-140	\$0.30	NUT		8

No. Part No. Price (each) Description Application Qty. Req.

103	322-290	\$0.45	BOLT, mounting bracket	from (c)138800	8
104	365-720	\$0.30	WASHER, plain	(1974)	16
105	310-290	\$0.65	NUT, nylon		8

C - 1275 Midget from (c)143355 to 154100 (mid 1974)

NOTE: Hardware for this application is the same as under illustration B.

110	400-370	NA	FACE BAR, front bumper (may use earlier bumper 400-270)		1
111	400-380	NA	SPRING BRACKET		1
112	400-390	NA	SUPPORT		1
113	400-400	NA	BRACKET		2
114	400-535	NA	REINFORCEMENT		2
115	280-690	\$1.95	GROMMET, front bumper		2
116	400-410	NA	OVERRIDER, R/H, front & rear		2
	400-420	NA	OVERRIDER, L/H, front & rear		2
117	400-580	NA	BRACKET, bumper to chassis, R/H		1
	400-590	NA	BRACKET, bumper to chassis, L/H		1
120	400-430	NA	BUMPER, L/H rear		1
	400-440	NA	BUMPER, R/H rear		1
121	400-450	NA	SPRING BRACKET		2
122	400-460	NA	BRACKET		2

D - Midget 1500 (1975-'80)

135	400-470	NA	BUMPER MOULDING, front		1
136	400-480	NA	ARMATURE, bumper		1
137	400-500	NA	RETAINER, moulding to armature		2
138	326-195	NA	RIVET		26
142	400-490	\$33.95	SUPPORT, upper moulding		1
143		NA	RIVET		4
144		NA	SPRING BRACKET, inner, RH		1
		NA	SPRING BRACKET, inner, LH		1
145	400-570	\$15.55	SPRING BRACKET, outer		2
146		NA	SCREW, outer bracket to body and armature		8
147	324-040	\$0.25	WASHER, locking		8
148	475-155	NA	WASHER, plain		8
149		NA	SCREW, inner spring bracket to armature		8
150	324-040	\$0.25	WASHER, locking		8
151	475-155	NA	WASHER, plain		8
152	324-040	\$0.25	WASHER, locking		4
153	475-155	NA	WASHER, plain		4
157	475-170	\$20.95	BADGE, 'MG', gold on black	some 1975 cars.	1
	475-165	\$16.95	BADGE, 'MG', silver on black	from (c)171431	1
	475-175	\$13.95	BADGE, 'MG', silver on bright red	alternative.	1
158	326-530	\$0.25	CLIP, push fix, badge to bumper		2
162	400-510	NA	BUMPER MOULDING, rear		1
163	400-520	\$129.95	ARMATURE, bumper		1
164	400-530	NA	RETAINER, moulding to armature, upper		1
165	400-540	NA	RETAINER, moulding to armature, lower		1
166	326-195	NA	RIVET		28
167	324-040	\$0.25	WASHER, locking		4
168	475-155	NA	WASHER, plain		4

Towing Eye / Common Hardware

175	400-575	\$15.95	TOWING EYE	all	2
176	320-285	\$0.50	BOLT, towing eye		4
177	324-040	\$0.25	LOCKWASHER		A/R
178	324-860	\$0.35	WASHER, plain		A/R
179	310-050	\$0.50	NUT		A/R
181	365-730	\$0.20	LOCKWASHER		A/R
182	365-720	\$0.30	WASHER, plain		A/R

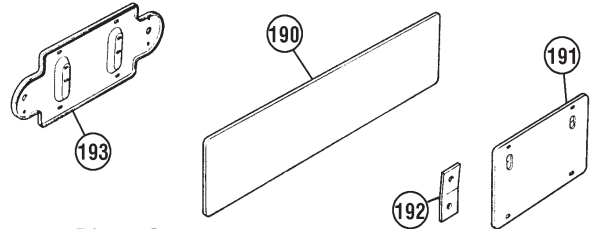

License Plate Supports

190	451-720	\$9.95	SUPPORT, license plate, British style		2
191	451-285	\$19.95	SUPPORT, license plate, for U.S. plates	} 948-1275 ft. & rear 1500 front	2
					1
192	402-560	\$4.55	BRACKET for front support	(all)	2
193	451-295	\$26.40	SUPPORT, license plate, rear, stock	} 1500	1
	451-296	\$40.95	SUPPORT, license plate, rear, stainless steel		1



Door Fittings

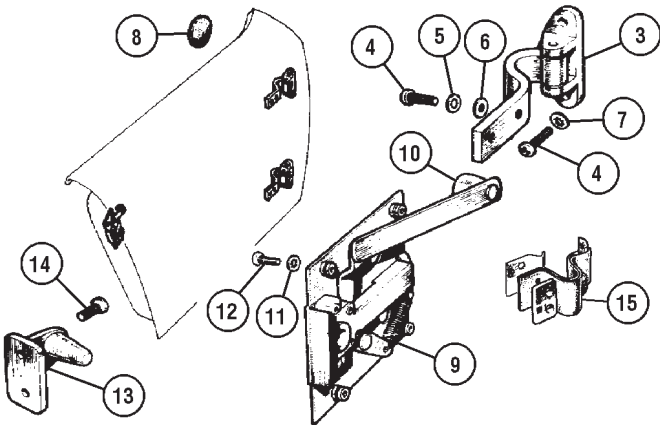

No.	Part No.	Price (each)	Description	Application	Qty. Req.
Early Doors, 1958-'63					
3	471-135	\$159.95	HINGE		4
4	322-495	\$0.45	SCREW		20
5	315-300	\$0.40	SPRING WASHER		8
6	324-590	\$0.20	FLAT WASHER		8
7	462-385	\$0.40	SPRING WASHER		12
8	282-140	\$1.25	PLUG, rubber	948cc cars only	8
9	402-640	\$29.95	LATCH, R/H		1
9A	402-650	\$29.95	LATCH, L/H		1
10	402-670	\$13.95	KNOB		2
11	324-110	\$0.10	SPRING WASHER		8
12	323-005	\$0.50	SCREW		8
13	470-540	\$9.70	STRIKER		2
14	323-255	\$0.75	SCREW		4
15			CHECK STRAP	(see #60-62 below)	2

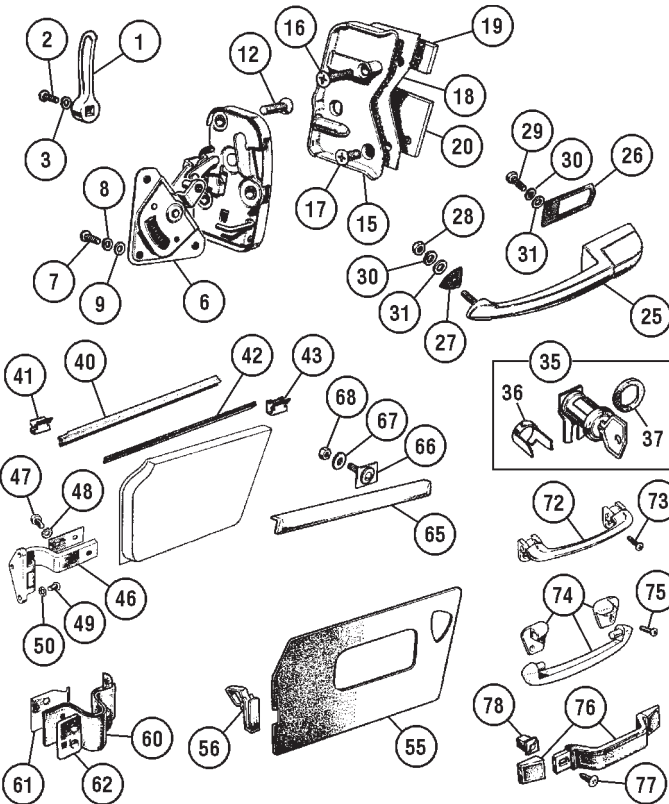

20	402-420	\$6.90	TAPPED PLATE, lower (in 'B' post)		2
25	402-660	\$29.95	EXTERIOR HANDLE ASS'Y		2
26	401-550	\$1.10	GASKET, handle to door, rear		2
27	401-540	\$1.05	GASKET, handle to door, front		2
28	310-040	\$0.15	NUT, handle to door		2
29	466-385	\$0.95	SCREW, handle to door		2
30	324-010	\$0.15	WASHER, locking		4
31	324-990	\$0.55	WASHER, plain		4
	470-458	\$72.95	MASTER LOCK SET, 3 pieces Includes 2 door locks, trunk handle & lock; keyed alike, with 2 keys		1
	470-448	\$34.95	LOCK SET, door Includes 2 door locks; keyed alike, with 2 keys		1
35	470-435	\$30.95	LOCK, R/H door with 2 keys		1
	470-440	\$30.95	LOCK, L/H door with 2 keys		1
36	401-590	NA	CLIP, lock retaining		2
37	402-170	\$0.65	GASKET, lock to door		2
40	282-175	\$10.95	WEATHER STRIP, door, outer, LH		1
	282-170	\$10.95	WEATHER STRIP, door, outer, RH		1
41	803-400	\$0.35	CLIP, outer weather strip to door		12
42	282-185	\$7.70	WEATHER STRIP, door, inner, LH		1
	282-180	\$7.70	WEATHER STRIP, door, inner, RH		1
43	317-065	\$0.95	CLIP, inner weather strip to door		12
46	471-140	\$75.95	HINGE, door		4
47	322-880	\$0.70	SCREW, hinge to door		8
48	315-300	\$0.40	WASHER, shakeproof		8
49	322-495	\$0.45	SCREW, hinge to 'A' post		12
50	462-385	\$0.40	WASHER, shakeproof		12
55			DOOR PANEL, see page 74.		
56	317-070	\$0.45	CLIP, door panel		18
60	240-670	\$9.95	CHECK STRAP, red	} all, including Bugeye	2
	240-675	\$9.95	CHECK STRAP, black		2
	240-680	NA	CHECK STRAP, blue		2
	240-685	\$9.95	CHECK STRAP, navy		2
	240-690	\$9.95	CHECK STRAP, autumn leaf		2
61	240-805	\$3.55	BRACKET, check strap		2
62	240-815	\$1.65	RETAINER, check strap	2	
65	402-700	NA	MOULDING, door top, untrimmed, RH		1
	402-705	NA	MOULDING, door top, untrimmed, LH		1
66	326-075	\$0.95	STUD PLATE, moulding to door top		4
67	315-085	\$0.15	WASHER, plain		4
68	159-340	\$0.55	NUT, nyloc		4
72	803-440	\$21.95	HANDLE, door pull, chrome	} Midget to (c)60459* } Sprite to (c)72040*	4
73	402-485	\$0.70	SCREW, chrome, handle to door		4
74	472-240	\$9.15	HANDLE, door pull, black	} Midget (c)60460-105500† } Sprite from (c)72041†	2
75	402-485	\$0.70	SCREW, chrome, handle to door		4
76	402-450	NA	HANDLE, door pull, autumn leaf	} Midget from (c)105501 (from 1972)	2
	402-455	\$14.95	HANDLE, door pull, yellow ochre		2
	402-453	\$14.95	HANDLE, door pull, black		2
	402-490	NA	HANDLE, door pull, navy		2
77	314-285	\$0.25	SCREW, handle to door		4
78	402-710	NA	CAPTIVE NUT	4	

No.	Part No.	Price (each)	Description	Application	Qty. Req.
Late Doors, 1964-'80					
1	402-685	\$13.95	HANDLE, remote control	} Midget to (c)60459* } Sprite to (c)72040*	2
2	323-205	\$0.80	SCREW, handle to remote control		2
	402-690	\$11.95	HANDLE, remote control	} Midget from (c)60460† } Sprite from (c)72041†	2
	323-005	\$0.50	SCREW, handle to remote control		2
3	324-010	\$0.15	LOCKWASHER		2
6	402-675	NA	REMOTE CONTROL, latch, LH		1
	402-680	NA	REMOTE CONTROL, latch, RH		1
7	323-005	\$0.50	SCREW, remote control to door		6
8	324-010	\$0.15	WASHER, locking		6
9	315-085	\$0.15	WASHER, plain		6
12	323-585	\$0.55	SCREW, latch to door		6
15	401-340	\$17.95	STRIKER PLATE, RH	} Midget to (c)60459* } Sprite to (c)72040*	1
	401-320	\$17.95	STRIKER PLATE, LH		1
	401-370	\$23.95	STRIKER PLATE, RH	} Midget from (c)60460† } Sprite from (c)72041†	1
	401-360	\$23.95	STRIKER PLATE, LH		1
16	323-195	\$0.95	SCREW, long, striker plate to 'B' post		2
17	323-280	\$0.95	SCREW, short, striker plate to 'B' post		4
18	402-410	\$3.40	SHIM, striker plate to 'B' post, 0.064"	A/R	
	402-415	\$1.95	SHIM, striker plate to 'B' post, 0.032"	A/R	
19	402-340	\$3.40	TAPPED PLATE, upper (in 'B' post)		2

* thru 1967 † from 1968

Wipers & Washers

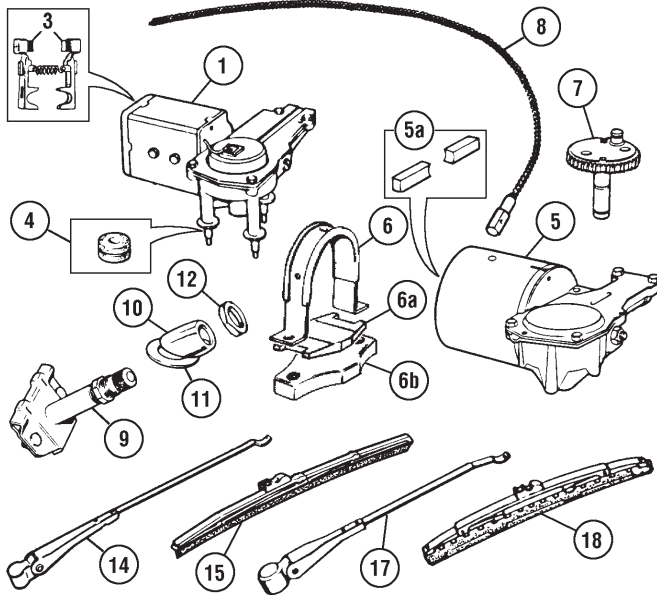

No.	Part No.	Price (each)	Description	Application	Qty. Req.
-----	----------	--------------	-------------	-------------	-----------

Sprite Mki-II, Midget Mki

.1	145-510	NA	WIPER MOTOR, less gear #7	{ replaces original units #75213 & 75387	1
3	554-035	\$19.95	BRUSH BLOCK PAIR (carbon blocks only)		1
4	280-755	\$2.75	MOUNTING GROMMET		3
7	145-320	NA	GEAR & SHAFT		1
8	161-310	\$19.95	CABLE ASS'Y., must be cut to match original length		1
9	145-200	\$44.95	WHEELBOX		2
10	145-290	\$5.45	BEZEL, chrome		2
11	282-820	\$1.40	PAD, bezel		2
12	311-065	\$2.85	NUT		2
14	165-005	\$15.95	WIPER ARM (LHD)		2
15	164-980	\$9.85	WIPER BLADE		2

Sprite MkIII-IV, Midget MkII-III thru 1967

1	145-510	NA	WIPER MOTOR, less gear #7	{ replaces units #75452, #75504 & #75801, 1963 - '671	1
2	554-030	NA	BRUSH ASSEMBLY		1
3	554-035	\$19.95	BRUSH PAIR (carbon blocks only)		1
4	280-755	\$2.75	MOUNTING GROMMET		3
7	145-535	NA	GEAR & SHAFT	{ original units #75452 & #75504	1
	560-360	NA	GEAR & SHAFT	replacement unit #75801	1
8	161-310	\$19.95	CABLE ASS'Y., must be cut to match original		1
9	145-217	\$49.95	WHEELBOX		2
10	145-290	\$5.45	BEZEL, chrome		2
11	282-820	\$1.40	PAD, bezel		2
12	145-205	\$2.80	NUT		2
14	165-005	\$15.95	WIPER ARM (LHD)		2
15	164-980	\$9.85	WIPER BLADE		2

All from 1968 on

5	145-490	\$106.95	WIPER MOTOR, less gear #7	{ replaces units #75660, #75664 & #75705	1
5a	145-590	\$24.45	BRUSH SET		1
6	145-645	\$10.20	STRAP, wiper motor mounting		1
6a	145-660	\$4.55	PAD		1
6b	145-665	NA	PACKING		1
7	145-575	\$24.95	GEAR & SHAFT	twin wipers	1
	145-555	\$29.95	GEAR & SHAFT	triple wipers	1
8	161-310	\$19.95	CABLE ASS'Y., must be cut to match original		1
9	145-150	NA	WHEELBOX	1968 - '74 1/2	2/3
	145-140	NA	WHEELBOX	1974 1/2 on	3
10	145-290	\$5.45	BEZEL, chrome		2/3
11	282-820	\$1.40	PAD, bezel		2/3
12	145-205	\$2.80	NUT		2/3

No.	Part No.	Price (each)	Description	Application	Qty. Req.
17	164-625	NA	WIPER ARM	1968	2
	164-610	\$24.95	WIPER ARM	1969 - '72	2/3
	164-615	\$16.95	WIPER ARM (stainless)	1973-'76	3
	164-635	\$17.95	WIPER ARM (black)	1977-'80	3
18	165-075	NA	WIPER BLADE	1968	2
	165-055	\$14.95	WIPER BLADE	1969 - '72	2/3
	165-046	\$14.95	WIPER BLADE (stainless)	1973-'76	3
	165-045	\$20.95	WIPER BLADE (black)	1977-'80	3

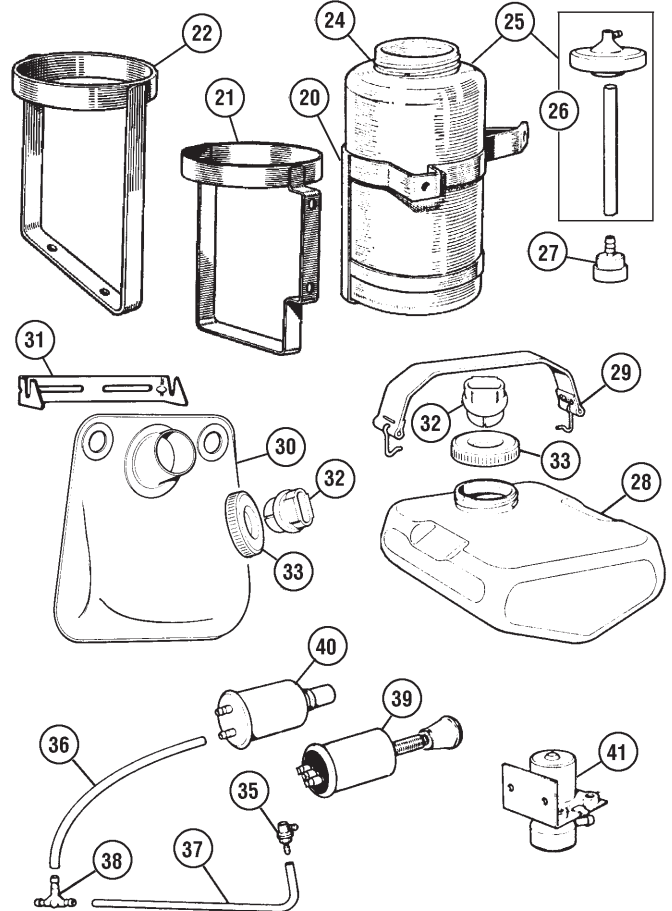

Windshield Washer

20	361-215	\$41.95	BRACKET, washer bottle	Sprite Mki,II, Midget Mki	1
21	361-245	\$13.95	BRACKET, washer bottle	from above thru 1967	1
22	361-275	\$10.95	BRACKET, washer bottle	1968-'74	1
24	361-125	\$57.95	CONTAINER (use with #20, 26, 27)	Sprite Mki,II, Midget Mki	1
25	361-148	\$19.95	CONTAINER ASS'Y., complete	1098 from '64 & 1275	1
26	361-140	\$13.95	CAP, with tube (included with #25 above)		1
27	361-145	\$4.00	FOOT VALVE (included with #25 above)		1
28	161-125	NA	CONTAINER	} 1500 to (c)166300	1
29	361-135	\$9.95	STRAP		1
30	361-120	\$27.95	CONTAINER, bag	} 1500 from (c)166301	1
31	361-270	\$6.15	BRACKET for bag		1
32	361-190	\$2.80	FILLER PLUG	} all 1500	1
33	361-150	\$3.75	CAP		1
35	361-240	\$4.75	JET, chromed	thru 1976	2
	361-260	\$4.80	JET, black	from 1977	2
36	361-210	\$1.95	TUBING, container to pump & pump to 3-way connector	} sold per foot	A/R
37	361-220	\$1.50	TUBING, connector to jets		A/R
38	361-235	\$2.60	CONNECTOR, 3-way		1
39	361-185	NA	PUMP, replacement type w/knob	948	1
40	361-160	\$31.95	PUMP, manual	1098	1
41	361-180	\$24.95	PUMP, electric	1275 & 1500	1

LOCAL & OVERSEAS: 805-681-3400

FAX: 805-692-2525 www.mossmotors.com

MOSS

SPRITE-MIDGET

Headlamps

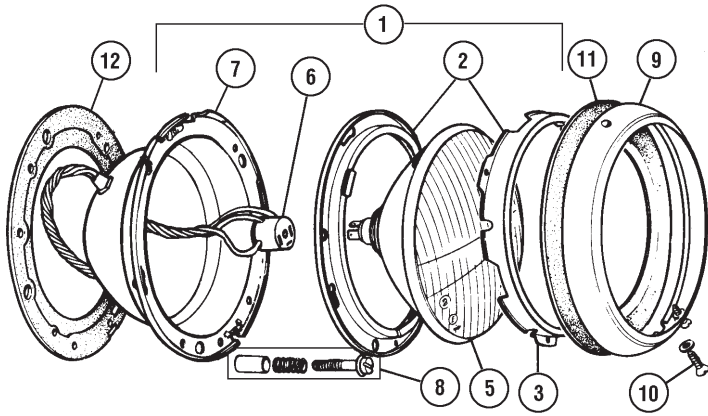

No.	Part No.	Price (each)	Description	Application	Qty. Req.
Headlamps - Bugeye to (c)19014					
1	168-708	\$99.95	HEADLAMP ASS'Y., sealed beam		2
2	157-300	\$32.95	RING ASS'Y., inner, 2 piece		2
3	156-700	\$10.95	RING, retaining		2
5	171-100	\$4.10	LIGHT UNIT, sealed beam, US made		2
	171-105	\$10.95	LIGHT UNIT, sealed beam, halogen (not in ass'y.)		2
6	171-400	\$9.45	PLUG, sealed beam, w/ grommet & pigtail		2
7	144-797	\$18.95	BUCKET with 3 adjusters		2
8	147-015	\$6.25	ADJUSTER SET, for 1 lamp		2
9	164-000	\$27.95	CHROME RIM, outer		2
10	147-000	\$0.85	SCREW		2
11	280-120	\$3.95	DUST SEAL		2
12	280-130	\$6.55	GASKET, lamp ass'y., to body		2

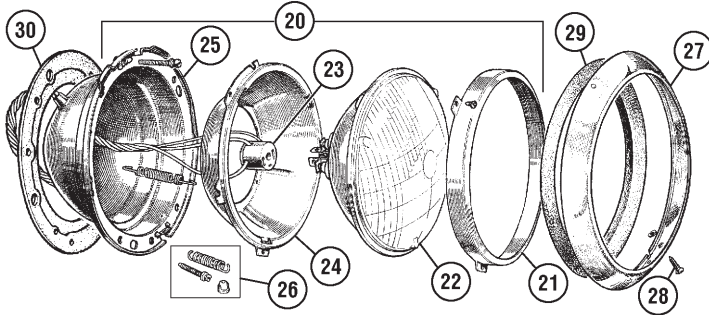

Headlamps - from Bugeye (c)19015 thru 1275

20	144-800	\$79.95	HEADLAMP ASS'Y., sealed beam		2
21	156-700	\$10.95	RING, retaining		2
22	171-100	\$4.10	LIGHT UNIT, sealed beam, US made		2
	171-105	\$10.95	LIGHT UNIT, sealed beam, halogen (not in ass'y.)		2
23	171-400	\$9.45	PLUG, sealed beam, w/ grommet & pigtail		2
24	560-215	\$16.95	RIM, inner		2
25	144-807	\$23.95	BUCKET with 2 adjusters		2
26	552-115	\$6.95	ADJUSTER SET, for 1 lamp		2
27	164-000	\$27.95	CHROME RIM, outer	Bugeye	2
	560-180	\$43.95	CHROME RIM, outer	all except Bugeye	2
28	147-000	\$0.85	SCREW		2
29	280-120	\$3.95	DUST SEAL		2
30	280-130	\$6.55	GASKET, lamp ass'y., to body	Bugeye	2
	164-050	\$9.95	GASKET, lamp ass'y., to body	all except Bugeye	2

Your headlamps won't light! Check the ground connector on the passenger side inner fender under the fresh air tube clamp on 948 - 1275 models.

Most lamp problems are caused by bad bulb contacts or corroded grounds. Don't assume major problems until the unit is completely inspected.

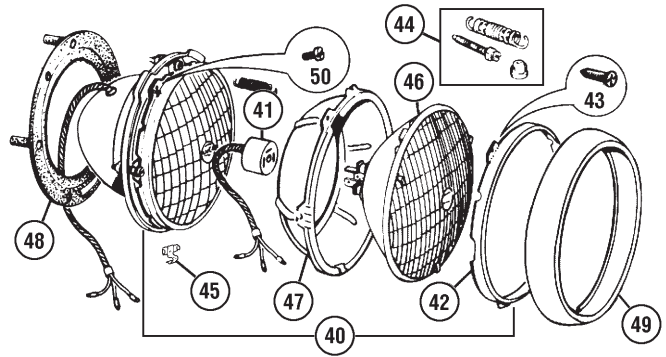

No.	Part No.	Price (each)	Description	Application	Qty. Req.
Headlamps - Midget 1500					
40	144-810	\$89.95	HEADLAMP ASSEMBLY		2
	169-130	NA	BUCKET ASSEMBLY		2
	144-807	\$23.95	BUCKET, bare		2
41	171-400	\$9.45	PLUG, w/grommet & pigtail		2
42	156-700	\$10.95	RING, retaining		2
43	158-045	\$0.40	SCREW		6
44	552-115	\$6.95	ADJUSTER SET		2
45	560-325	\$2.55	CLIP, rim securing		2
46	171-100*	\$4.10	LIGHT UNIT, sealed beam		2
	560-215	\$16.95	RIM, inner		2
48	164-060	\$6.95	SEAL, lamp seating		2
49	164-020	\$34.95	RIM, outer (1975-'79)		2
	164-015	\$42.95	RIM, outer, with notch (1980)		2
50	373-960	\$0.55	SCREW, to body		8

* Note: See the Accessories Section at the front of this catalog for alternative headlamps.

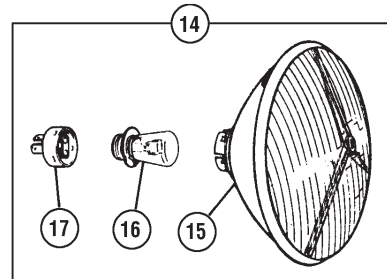

14	156-878*	\$176.95	TRIPOD HEADLAMP SET		1
			2 complete units, with bulbs & adaptors		
15	156-870*	\$76.95	TRIPOD UNIT, lens & reflector only		2
16	170-600*	\$8.40	BULB		2
17	157-000*	\$18.95	ADAPTOR, bulb to plug		2
	170-695	\$19.95	HALOGEN BULB 65/55 watts	optional for above	2

* Note: Tripod headlamps are semi-sealed units with replaceable bulbs, and are not legal for street use where D.O.T. approved headlamps are required.

moss

MOSS MOTORS, LTD. TOLL-FREE ORDERS 1-800-667-7872

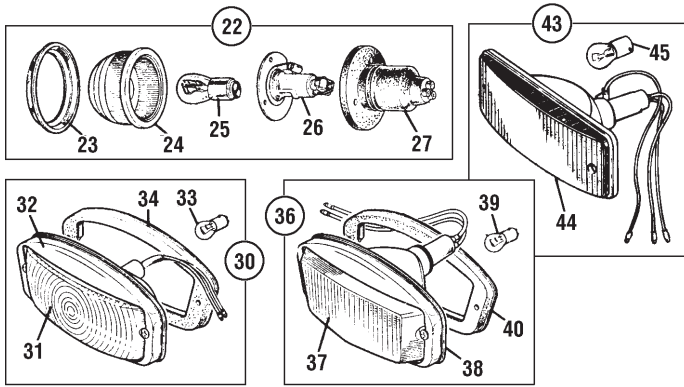

No.	Part No.	Price (each)	Description	Application	Qty. Req.
Front Side/Flashers					
22	544-050	\$29.95	LAMP ASSEMBLY, side/flasher	Bugeye	2
23	158-400	\$4.95	RIM, chrome		2
24	560-270	\$16.95	LENS, clear		2
25	170-700	\$0.95	BULB		2
26	552-120	\$9.95	SOCKET		2
27	159-600	\$4.75	BODY, rubber		2

30	159-060	NA	LAMP ASSEMBLY, side/flasher clear lens (use #36 as repl.)	1961 - '67	2
	159-065	NA	LAMP ASSEMBLY, side/flasher amber lens (use #36 as repl.)	1968 - '69	2
31	159-048	\$41.95	LENS PAIR, clear (replacement - Euro-spec, glass)	1961 - '67	1
	159-075	NA	LENS, amber	1968 - '69	2

32	159-050	\$27.95	RIM	1961 - '69	2
33	170-700	\$0.95	BULB		2
34	159-085	\$6.95	GASKET, lens seating		2
36	159-090	\$85.95	LAMP ASSEMBLY, side/flasher		2
37	159-095	\$22.95	LENS	Midget 1970 - '74	2
38	159-050	\$27.95	RIM		2
39	170-700	\$0.95	BULB		2
40	159-085	\$6.95	GASKET, lens seating		2

43	164-155	\$109.95	LAMP ASSEMBLY, side/flasher	Midget 1500	2
44	164-815	\$14.95	LENS, amber, with screw & seal		2
	323-035	\$0.45	SCREW, lens to base		2
	164-120	\$1.95	SEAL, lens to base		2
45	170-700	\$0.95	BULB		2

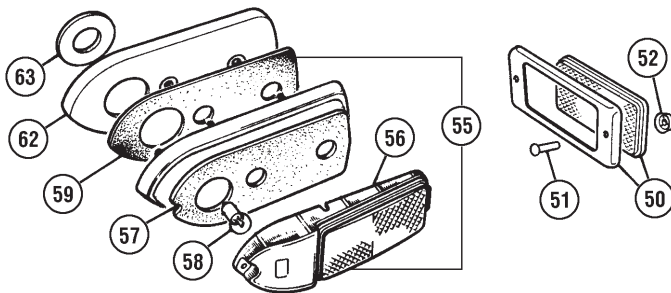

No.	Part No.	Price (each)	Description	Application	Qty. Req.
Front Side Markers					
50	570-180	\$29.95	REFLECTOR & RIM, front, amber	1275, 1968 - '69	2
51	158-230	NA	RIVET, reflector to body		4
52	158-235	NA	PUSH-ON FIX, rivet		4
55	164-845	\$84.95	SIDE MARKER, L/H front	Midget 1970 on	1
	164-855	\$84.95	SIDE MARKER, R/H front		1
56	164-885	\$18.95	LENS, L/H, w/ screws & gaskets		1
	164-890	\$18.95	LENS, R/H, w/ screws & gaskets		1
57	164-910	\$1.95	GASKET, lens seating		2
58	170-250	\$0.95	BULB		2
59	164-915	\$5.70	GASKET, lamp to plinth		2
62		NA	PLINTH, L/H		1
		NA	PLINTH, R/H		1
63	164-130	NA	WASHER, sealing		2

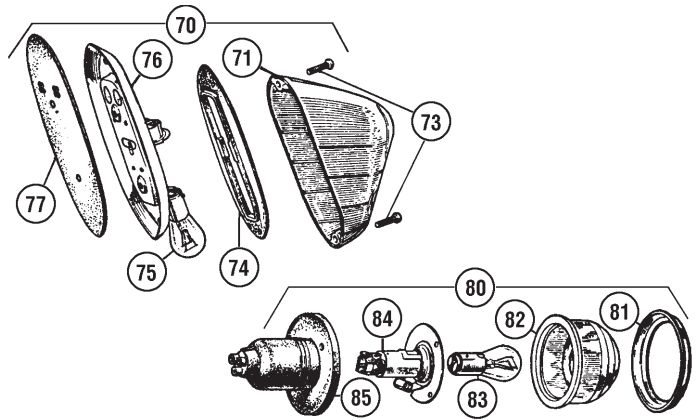

No.	Part No.	Price (each)	Description	Application	Qty. Req.
Taillight - Bugeye					
70	143-800	\$41.95	TAIL LAMP ASSEMBLY	Bugeye	2
71	159-200	\$11.95	LENS, Lucas		2
	159-210	NA	LENS, aftermarket		2
73	323-420	\$1.85	SCREW for lens		4
74	159-100	\$2.95	PAD, lens mounting		2
75	170-700	\$0.95	BULB		2
76	159-300	\$22.95	BASE ASSEMBLY, chrome		2
77	159-400	\$2.95	PAD, lamp mounting		2
80	144-000	\$28.95	FLASHER LAMP ASSEMBLY		2
81	158-400	\$4.95	RIM, chrome		2
82	164-900	\$11.95	LENS, red		2
83	170-800	\$0.95	BULB		2
84	159-900	\$10.95	SOCKET		2
85	159-600	\$4.75	BODY, rubber		2

70	143-800	\$41.95	TAIL LAMP ASSEMBLY	Bugeye	2
71	159-200	\$11.95	LENS, Lucas		2
	159-210	NA	LENS, aftermarket		2
73	323-420	\$1.85	SCREW for lens		4
74	159-100	\$2.95	PAD, lens mounting		2
75	170-700	\$0.95	BULB		2
76	159-300	\$22.95	BASE ASSEMBLY, chrome		2
77	159-400	\$2.95	PAD, lamp mounting		2
80	144-000	\$28.95	FLASHER LAMP ASSEMBLY		2
81	158-400	\$4.95	RIM, chrome		2
82	164-900	\$11.95	LENS, red		2
83	170-800	\$0.95	BULB		2
84	159-900	\$10.95	SOCKET		2
85	159-600	\$4.75	BODY, rubber		2

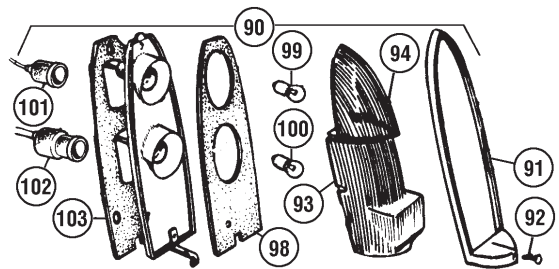

No.	Part No.	Price (each)	Description	Application	Qty. Req.
Taillight - 1961-1969					
90	144-390	\$89.95	TAIL LAMP ASS'Y., w/ 2 pc. lens	from Sprite MkII & Midget MkI thru 1969	2
91	164-790	\$21.95	RIM		2
92	323-090	\$0.90	SCREW		2
93	164-820	\$19.95	LENS, stop/tail, original Lucas		2
	164-720	\$7.95	LENS, stop/tail, quality repro.		2
94	164-830	\$18.95	LENS, flasher, original Lucas		2
	164-730	\$7.95	LENS, flasher, quality repro.		2
	164-725	\$14.95	LENS, flasher, amber (Euro. spec.)		2
98	164-840	\$2.95	PAD, lens seating		2
99	170-800	\$0.95	BULB, flasher		2
100	170-700	\$0.95	BULB, stop/tail		2
101	158-150	NA	GROMMET, flasher wire		2
102	158-160	\$0.95	GROMMET, stop/tail wire		2
103	164-870	\$1.90	PAD, lamp to car	2	

Lamps

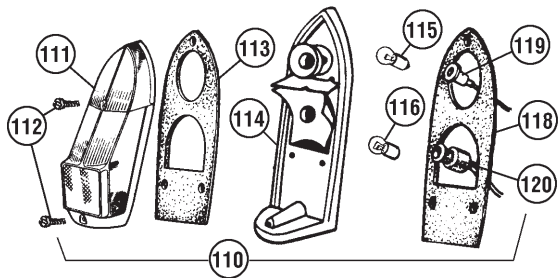

No.	Part No.	Price (each)	Description	Application	Qty. Req.
-----	----------	--------------	-------------	-------------	-----------

Taillight - Midget 1970 on

110	144-395	\$126.95	TAIL LAMP ASSEMBLY, w/ 1 pc. lens	} Midget, 1970 on	2
111	164-835	\$33.95	LENS, Lucas		2
	164-735	\$19.95	LENS, quality replacement		2
112	NA		SCREW, lens to base		4
113	164-883	\$2.95	GASKET, lens seating		2
114	164-785	NA	LAMP BASE, chrome		2
115	170-700	\$0.95	BULB, stop/tail		2
116	170-800	\$0.95	BULB, flasher		2
118	164-880	\$2.95	GASKET, lamp to car		2
119	158-160	\$0.95	GROMMET, stop/tail wires		2
120	158-150	NA	GROMMET, flasher wire		2

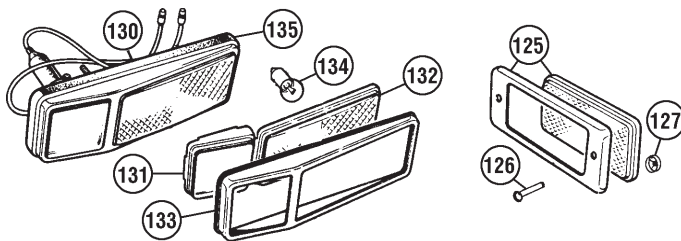

Rear Side Markers

125	144-720	\$19.95	REFLECTOR & RIM, rear, red	} 1275, 1968 - '69	2
126	158-230	NA	RIVET, reflector to body		4
127	158-235	NA	PUSH-ON FIX, rivet		4
130	164-135	\$77.95	SIDE MARKER ASSEMBLY, rear	} Midget, 1970 on	2
131	164-140	\$28.95	LENS, red		2
132	164-150	\$19.95	LENS, reflector		2
133	164-145	\$41.95	RIM		2
134	170-250	\$0.95	BULB		2
135	282-260	\$11.95	BASE, rubber		2

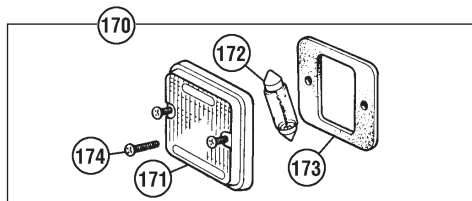

Reverse Lamps

170	144-590	\$29.95	REVERSE LAMP	} 1275 & 1500	2
171	164-860	\$11.95	LENS		2
172	170-140	\$0.95	BULB		2
173	159-110	\$1.95	PAD, lens & lamp seating		4
174	158-220	\$0.55	SCREW		4
178	158-940	\$10.95	TRUNK LAMP, interior		1

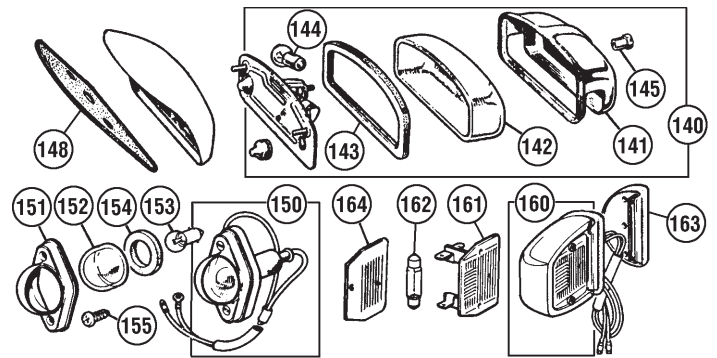

No.	Part No.	Price (each)	Description	Application	Qty. Req.
-----	----------	--------------	-------------	-------------	-----------

License Lamps

140	144-190	\$60.95	LICENSE PLATE LAMP, Lucas	} all thru 1969	1
	144-200	\$26.95	LICENSE PLATE LAMP, repro.		1
141	158-100	\$10.95	COVER, chrome		1
142	164-100	\$7.00	LENS		1
143	280-540	\$4.80	SEAL, lens to base		2
144	170-250	\$0.95	BULB		1
145	158-200	\$2.50	SCREW, cover		1
147	144-240	\$62.95	PLINTH, lamp mounting	} Bugeye	1
148	159-020	\$6.85	GASKET, plinth to body		1
	159-025	\$2.95	GASKET, plinth to body	} Sprite MkII on Midget thru 1969	1
150	144-180	\$64.95	LICENSE PLATE LAMP ASS'Y.		2
151	158-510	\$13.95	COVER	} Midget 1970 - 74 split rear bumper	2
152	158-500	\$15.95	LENS		2
153	170-250	\$0.95	BULB		2
154	158-520	\$1.75	PAD, lens seating		2
155	159-330	\$1.05	SCREW, lamp mounting		4
160	144-220	\$29.95	LICENSE LAMP ASS'Y., chrome	} Midget 1500 to (c)182000	2
161	158-915	\$7.65	LENS & BULB HOLDER		2
162	170-010	\$1.05	BULB		2
163	144-225	\$5.45	GROMMET, base		2
	144-230	\$17.95	LICENSE LAMP ASS'Y., black	} Midget 1500 from (c)182001	2
164	158-910	\$4.60	LENS		2
	170-010	\$1.05	BULB		2

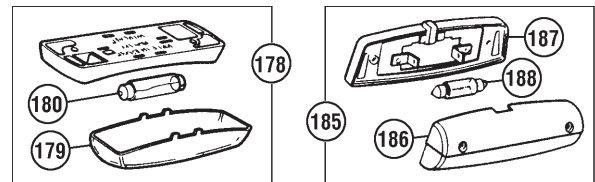

178	158-940	\$10.95	TRUNK LAMP, interior	} Sprite MkIII on Midget MkII on	1
179	158-945	\$6.85	LENS		1
180	170-010	\$1.05	BULB		1
185	158-920	\$25.95	COURTESY LAMP, fixed		1
186	158-925	\$12.95	LENS & BEZEL		1
187	158-930	NA	PLATE & SWITCH		1
188	170-010	\$1.05	BULB		1

Wiring Harnesses

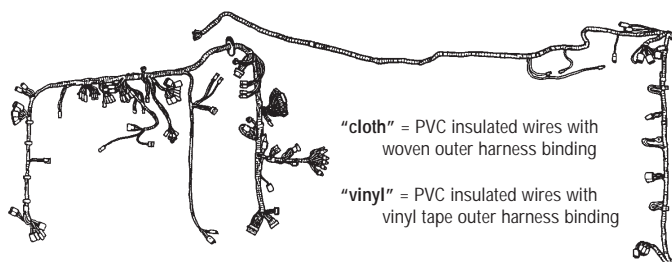

No.	Part No.	Price (each)	Description	Application	Qty. Req.
Sprite Wiring Harnesses					
356-100	\$321.95	WIRING HARNESS, cloth	{ HAN5-501 to 50116 1958 - '61 (Bugeye)		
355-015*	\$333.95	WIRING HARNESS, cloth	{ HAN6-101 to 24731 1961 (MkII)		
355-025*	\$341.95	WIRING HARNESS, cloth	{ HAN7-24732 to 38828 1962 - '64 (MkII)		
355-035*	\$422.95	WIRING HARNESS, cloth	{ HAN8-38829 to 64734 1966 - '67 (MkIII)		
356-805*	\$385.95	WIRING HARNESS, cloth	{ HAN9-64735 to 70267 (MkIV)		
356-815*	\$373.95	WIRING HARNESS, cloth	{ HAN9-70268 to 72033 (MkIV)		
356-828*	NA	WIRING HARNESS, cloth	{ HAN9-72034 to 77590 (MkIV)		
356-830	\$302.95	MAIN HARNESS, vinyl	{ HAN9-77591 to 85286 (MkIV)		
356-807	\$87.95	REAR HARNESS, vinyl			
356-840	\$326.95	MAIN HARNESS, vinyl	{ HAN10-85287 on (MkIV)		
356-847	NA	REAR HARNESS, vinyl			

Midget Wiring Harnesses

355-015*	\$333.95	WIRING HARNESS, cloth	{ GAN1-101 to 16183 1961 - '62 (MkI)		
355-025*	\$341.95	WIRING HARNESS, cloth	{ GAN2-16184 to 25787 1962 - '64 (MkI)		
355-035*	\$422.95	WIRING HARNESS, cloth	{ GAN3-25788 to 52411 1964 - '66 (MkII)		
356-805*	\$385.95	WIRING HARNESS, cloth	{ GAN4-52412 to 58111 (MkIII)		
356-815*	\$373.95	WIRING HARNESS, cloth	{ GAN4-58112 to 60440 (MkIII)		
356-828*	NA	WIRING HARNESS, cloth	{ GAN4-60441 to 66224 (MkIII)		
356-830	\$302.95	MAIN HARNESS, vinyl	{ GAN4-66225 to 74885 (MkIII)		
356-807	\$87.95	REAR HARNESS, vinyl			
356-840	\$326.95	MAIN HARNESS, vinyl	{ GAN5-74886 to 89514 (MkIII)		
356-847	NA	REAR HARNESS, vinyl			
356-850	\$339.95	MAIN HARNESS, vinyl	{ GAN5-89515 to 105500 (MkIII)		
356-857	\$91.95	REAR HARNESS, vinyl			
356-860	\$329.95	MAIN HARNESS, vinyl	{ GAN5-105501 to 112275 (MkIII)		
356-867	\$94.95	REAR HARNESS, vinyl			
356-870	\$329.95	MAIN HARNESS, vinyl	{ GAN5-112276 to 123730 (MkIII)		
356-877	\$75.95	REAR HARNESS, vinyl			
356-880	\$310.95	MAIN HARNESS, vinyl	{ GAN5-123731 to 138000 (MkIII)		
356-877	\$75.95	REAR HARNESS, vinyl			
356-890	\$311.95	MAIN HARNESS, vinyl	{ GAN5-138001 to 154100 (MkIII)		
356-897	NA	REAR HARNESS, vinyl			
356-900	\$340.95	MAIN HARNESS, vinyl	{ GAN6-154101 to 159053 (1500)		
356-988	\$187.95	DASH HARNESS, vinyl			
356-907	NA	REAR HARNESS, vinyl			

356-910	\$340.95	MAIN HARNESS, vinyl	{ GAN6-159054 to 166300 (1500)		
356-988	\$187.95	DASH HARNESS, vinyl			
356-917	NA	REAR HARNESS, vinyl			
356-920	\$323.95	MAIN HARNESS, vinyl	{ GAN6-166304 to 188000 (Federal)		
356-988	\$187.95	DASH HARNESS, vinyl			
356-917	NA	REAR HARNESS, vinyl			
356-920	\$323.95	MAIN HARNESS, vinyl	{ GAN6-166304 to 200000 (California)		
356-988	\$187.95	DASH HARNESS, vinyl			
356-917	NA	REAR HARNESS, vinyl			
356-947	NA	MAIN HARNESS, vinyl	{ GAN6-188001 to 200000 (Federal)		
356-988	\$187.95	DASH HARNESS, vinyl			
356-917	NA	REAR HARNESS, vinyl			
356-957	NA	MAIN HARNESS, vinyl	{ GAN6-200001 on (Federal)		
356-998	NA	DASH HARNESS, vinyl			
356-917	NA	REAR HARNESS, vinyl			
356-967	NA	MAIN HARNESS, vinyl	{ GAN6-200001 to 212000 (California)		
356-998	NA	DASH HARNESS, vinyl			
356-917	NA	REAR HARNESS, vinyl			
356-977	NA	MAIN HARNESS, vinyl	{ GAN6-212001 on (California)		
356-998	NA	DASH HARNESS, vinyl			
356-917	NA	REAR HARNESS, vinyl			

*Note: These wiring harnesses include main and body-rear harness. All harnesses may not include minor sub-harnesses such as headlight to headlight, horn to horn, dimmer switch, and dash light wires.

Sub-Harnesses

356-825	\$17.95	DIMMER SWITCH HARNESS	Sprite MkI,II, Midget MkI	1
356-835	\$24.95	DIMMER SWITCH HARNESS	Sprite MkIII,IV, Midget MkII,III	1

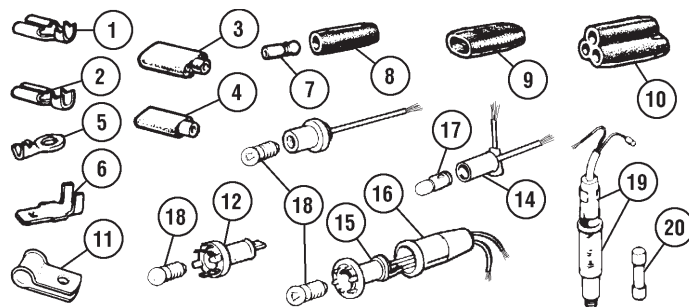

Wiring Fittings

1	161-580	\$1.10	CLIP, 35 amp	A/R
2	161-520	\$0.65	CLIP, 17.5 amp	A/R
3	161-540	\$0.55	INSULATOR, 35 amp clip	A/R
4	161-570	\$0.45	INSULATOR, 17.5 amp clip	A/R
5	161-740	\$0.55	EYELET, 3/16"	A/R
	161-750	NA	EYELET, 1/4"	A/R
	161-760	\$0.70	EYELET, 5/16"	A/R
6	162-205	\$0.35	BLADE	A/R
7	162-200	\$0.35	WIRE NIPPLE	A/R
8	162-000	\$0.75	CONNECTOR, single	A/R
9	161-600	\$0.95	CONNECTOR, double	A/R
10	161-720	NA	CONNECTOR, triple (use 3 x #8)	A/R
11	470-830	\$0.85	CLIP, 1/4" cable dia. 7/32" hole	A/R
	162-210	\$0.65	CLIP, 1/4" cable dia. 9/32" hole	A/R
	162-250	\$0.65	CLIP, 3/8" cable dia. 7/32" hole	A/R
	162-310	\$0.65	CLIP, 5/8" cable dia. 9/32" hole	A/R
12	161-915	\$6.35	BULB HOLDER	A/R
13	158-330	NA	BULB HOLDER	A/R
14	158-340	\$7.95	BULB HOLDER	A/R
15	158-320	\$6.50	BULB HOLDER	A/R
16	158-360	NA	SLEEVE, bulb holder	A/R
17	170-110	\$0.95	BULB, "eared" base	A/R
18	171-000	\$1.20	BULB, screw base	A/R
19	146-750	\$3.10	FUSE HOLDER, in-line	A/R
20	146-730	\$0.95	FUSE, 10 amp (for in-line holder)	A/R

Wiring Harness Tape

This tape is not self-adhesive. Examine your old harness carefully to see how ends and branches are accomplished.

- 162-030 Blue Harness Tape \$5.55
- 162-025 Black Harness Tape \$5.55

LOCAL & OVERSEAS: 805-681-3400

FAX: 805-692-2525 www.mossmotors.com

MOSS

Distributors - 948-1275s

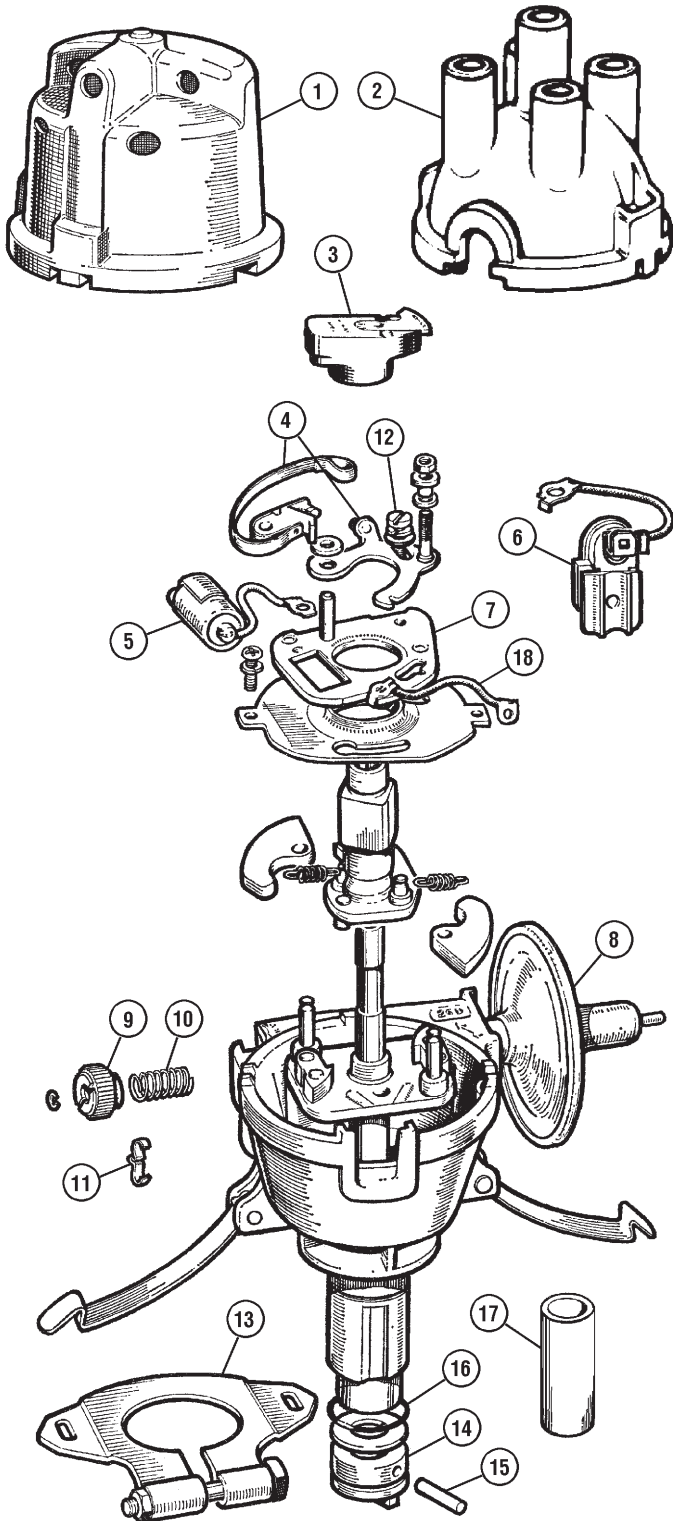

No.	Part No.	Price (each)	Description	Application	Qty. Req.
New Lucas distributors for Sprites and Midgets are no longer available. See below for Mallory replacements.					
1	163-805	\$29.95	DISTR. CAP, side entry, Lucas		1
	163-800	\$19.95	DISTR. CAP, side entry, replacement		1
2	163-815	\$15.95	DISTR. CAP, top entry, Lucas		1
	163-810	\$7.95	DISTR. CAP, top entry, replacement		1
3	151-710	\$3.55	ROTOR, Lucas		1
	151-800	\$2.95	ROTOR, replacement		1
4	151-720	\$5.45	POINT SET, Lucas		1
	153-900	\$3.95	POINT SET, replacement		1
5	151-730	\$4.85	CONDENSER, Lucas		1
	154-000	\$2.95	CONDENSER, replacement		1
6	153-600	\$16.95	TERMINAL & LEAD	948	1
	153-640	\$8.75	TERMINAL & LEAD	1098 & 1275	1
7	153-700	NA	BREAKER PLATE		1
8	163-630	\$74.95	VACUUM UNIT	948 & 1098	1
	163-675	\$60.95	VACUUM UNIT	1275	1
9	163-735	NA	NUT, adjuster		1
10	163-730	NA	SPRING, adjuster		1
11	163-740	NA	RATCHET, adjuster		1
12	323-245	\$0.95	SCREW, points retaining		1
13	153-400	\$26.95	CLAMPING PLATE with bolt & nut		1
	153-401	\$24.95	CLAMPING PLATE without bolt & nut		1
14	153-300	\$18.95	DRIVING DOG		1
15	539-020	\$0.60	PIN		1
16	163-750	\$0.75	"O" RING	as fitted	1
17	153-100	\$69.95	BUSHING		1
18	153-645	\$1.95	GROUND WIRE (replacement)		1

Mallory Dual Point Distributor

Dual point design produces hotter sparks than standard distributors. The mechanical advance-only design is adjustable to 24 degrees total advance, making these units suitable for stock or race prepared engines. Installation and adjustment is straightforward (instructions are provided), but a distributor drive dog must be installed, and the shaft drilled for the pin. The optional Advance Curve Kit includes a large assortment of advance weight springs, a degree key tool and instructions, allowing you to set whatever advance curve you want.



Dual-Point Distributor	143-180	\$280.95
Replacement Cap	143-175	\$28.95
Replacement Points (2 req.)	143-185	\$18.95
Replacement Rotor	143-190	\$7.65
Replacement Condenser	143-195	\$7.60
Advance Curve Kit	143-236	\$40.95

Crane XR-700 Electronic Ignition

Replace your troublesome points and condenser with this easily installed kit. Crane electronic ignition systems are famous for their reliability. Expect faster starts, cleaner running and better performance at all engine speeds.

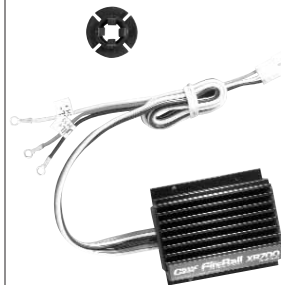

222-680	Electronic Ignition, 4 cyl. (point-type distributor, positive or negative ground)	\$130.95
222-325	Electronic Ignition, 4 cyl. (orig. electronic ignition with internal amp.)	\$128.95
222-655	Electronic Ignition, 4 cyl. (orig. electronic ignition with remote amp.)	NA

moss

MOSS MOTORS, LTD.
TOLL-FREE ORDERS

1-800-667-7872

"Opus"

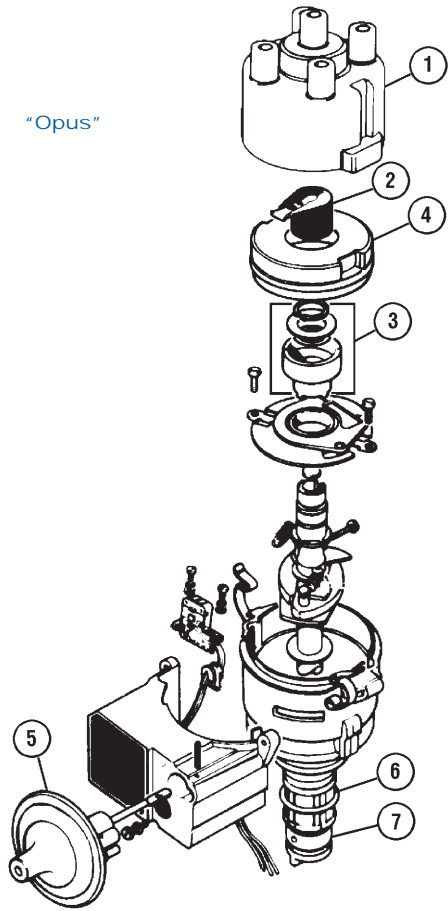

C.E.I.

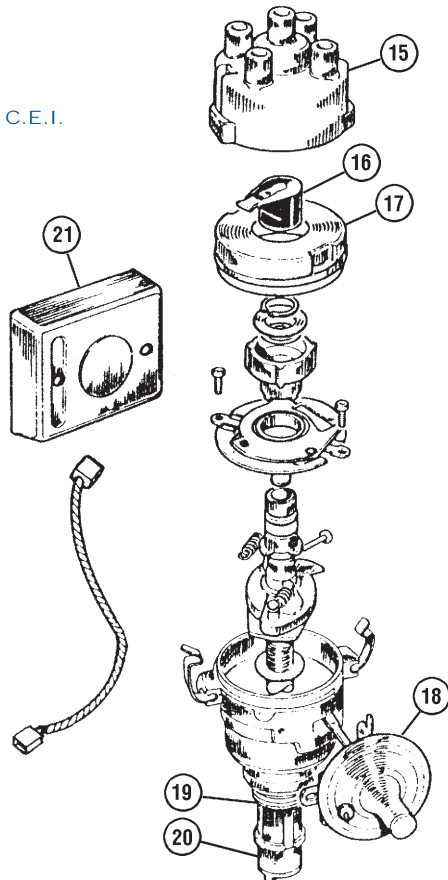

Lucas Electronic Ignition

The original Lucas "Opus" electronic ignition system used through 1979 featured the amplifier module mounted on the distributor body. As this system proved notoriously troublesome and unreliable, all replacements made as of 1980 were of the C.E.I. (Constant Energy Ignition) type, with a remotely mounted amplifier. Needless to say, this has caused much confusion during the intervening years when replacement components have been required. Order parts based on your distributor number.

Model Year	Orig. Opus distributor#	Replacement C.E.I. distributor #
1975	41593	41804
1976 Fed.	41646	41805
1976 CA	41656	41804
1977-79 Fed.	41697	41807
1977-79 CA	41698	41808

No.	Part No.	Price (each)	Description	Application	Qty. Req.
-----	----------	--------------	-------------	-------------	-----------

Opus System

1	151-870	\$7.45	CAP		1
2	151-850	\$2.70	ROTOR ARM		1
3	154-050	NA	TIMING ROTOR		1
4	154-030	NA	ANTI-FLASH COVER	{ Opus distr. #41593 & 41656	1
	154-040	\$22.95	ANTI-FLASH COVER	{ Opus distr. #41646, 41697 & 41698	1
5	142-890	NA	VACUUM UNIT	{ Opus distr. #41593 & 41656	1
	142-900	NA	VACUUM UNIT	{ Opus distr. #41646, 41697 & 41698	1
6	163-750	\$0.75	O-RING		1
7	153-300	\$18.95	DRIVING DOG		1
	539-020	\$0.60	PIN for driving dog		1

C.E.I. System

15	151-870	\$7.45	CAP		1
16	151-850	\$2.70	ROTOR ARM		1
17	154-040	\$22.95	ANTI-FLASH COVER		1
18		NA	VACUUM UNIT	C.E.I. distr. #41804	1
	071-690	NA	VACUUM UNIT	{ C.E.I. distr. #41805 & 41808	1
		NA	VACUUM UNIT	C.E.I. dist. #41807	1
19	163-750	\$0.75	O-RING		1
20	153-300	\$18.95	DRIVING DOG		1
	539-020	\$0.60	PIN for driving dog		1
21	142-975	\$272.95	AMPLIFIER		1

Ignitor Electronic Ignition

- The solution to your Lucas distributor woes.
- Completely self contained. Fits inside your original distributor
- Simple installation. Only two wires to hook up. No permanent modifications involved.
- No points to set or change.
- Impervious to dust, moisture, or vibration and retains stock advance curve.
- Much less affected by distributor shaft wear, firing accuracy to within 1/4". (Distributor not included!)



Points-type distributor (positive ground)	222-555	\$127.95
Points-type distributor (negative ground)	222-405	\$110.95
1500 with "Opus" electronic ignition	222-425	\$110.95
1500 with "C.E.I." electronic ignition	222-475	\$110.95

Ignition

Lucas Sports Coil

40,000 volt output gives more reliable starting power, and greater performance at high rpm. Works with non-ballasted ignition systems only.

143-200 \$46.95



Crane Ignition Coil

A tired, low energy ignition coil will rob your car of valuable power. The Crane PS40 "nickel plated" coil is perfect for street or high performance applications where sustained high r.p.m. use can outrun a standard coil.

143-240 PS40 Nickel Plate Coil \$58.95

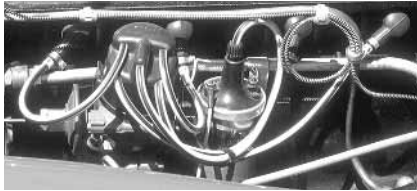

Lucas "Bumblebee" Ignition Wire

Its bright yellow and black coloring led to its descriptive nickname. This solid copper core wire is so good it was used for years by factory teams. Sold per foot.

571-020 \$3.25 per foot

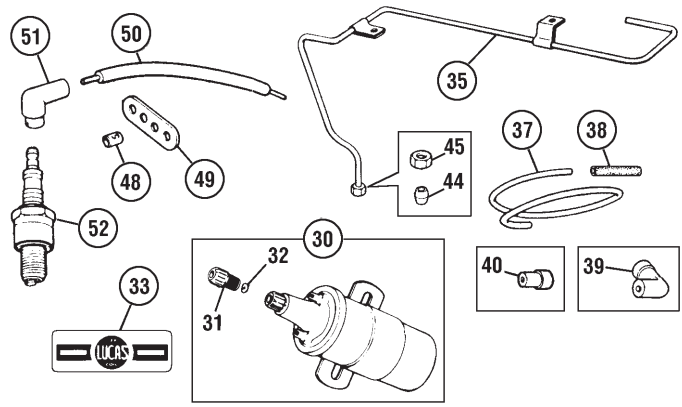

No.	Part No.	Price (each)	Description	Application	Qty. Req.
30	543-020	\$20.95	IGNITION COIL, w/screw connector	as illustrated, thru 1275	1
	143-220	\$28.95	IGNITION COIL, push-in connector	thru 1275 (repl. for above)	1
	143-230	\$33.95	IGNITION COIL	1500	1
	143-200	\$46.95	LUCAS SPORTS COIL - Lucas' top of the line coil for road and mild competition use. Not for ballasted (eg.1500) ignition systems.		1
31	152-400	\$1.75	NUT, wire securing	} used with and included with coil #543-020	1
32	146-310	\$0.80	WASHER, brass		1
33	215-630	\$2.95	"LUCAS" COIL DECAL	948	1
35		NA	VACUUM LINE	1098 & 1275	1
		NA	VACUUM LINE	1275 & 1500	A/R
37	163-655	\$1.25	VACUUM LINE, plastic, per ft.	1098 & 1275	1
38	282-650	\$3.40	CONNECTOR, metal pipe to carb.	1275 & 1500	1
	153-830	\$1.95	CONNECTOR, plastic pipe to carb.		1
39	153-840	\$2.35	CONNECTOR, to vacuum unit		1
40		NA	CONNECTOR	1500	1
44	163-635	\$0.75	COMPRESSION FITTING		1
45	153-810	\$3.75	NUT		1
48	171-630	\$3.60	WIRE LABEL SET, "1, 2, 3, 4"		1
49	171-550	\$2.25	IGNITION WIRE SEPARATOR		1
50	171-628	\$32.95	IGNITION WIRE SET, side entry cap	} 948, 1098, 1275	1
	171-660	\$22.95	IGNITION WIRE SET, top entry cap		1
	171-670	\$15.95	IGNITION WIRE SET, stock type		1
	143-556	\$39.95	IGNITION WIRE SET, "Magnecore"		1500
51	171-620	\$6.55	CLIP, suppressor	all	4
52	152-120	\$2.30	SPARK PLUG, "Champion"	948-1098	4
	152-130	\$2.30	SPARK PLUG, "Champion"	1275	4
	860-051	\$2.30	SPARK PLUG, "Champion"	1500	4

Tar-Top Battery

This is the correct battery for early Sprites and Midgets. Not only do they fit right, and the terminals are in the correct positions, but they have the true original style "tar top" construction. For 1958-'67 positive ground cars.

459-480 \$200.95



moss

MOSS MOTORS, LTD.
TOLL-FREE ORDERS

1-800-667-7872

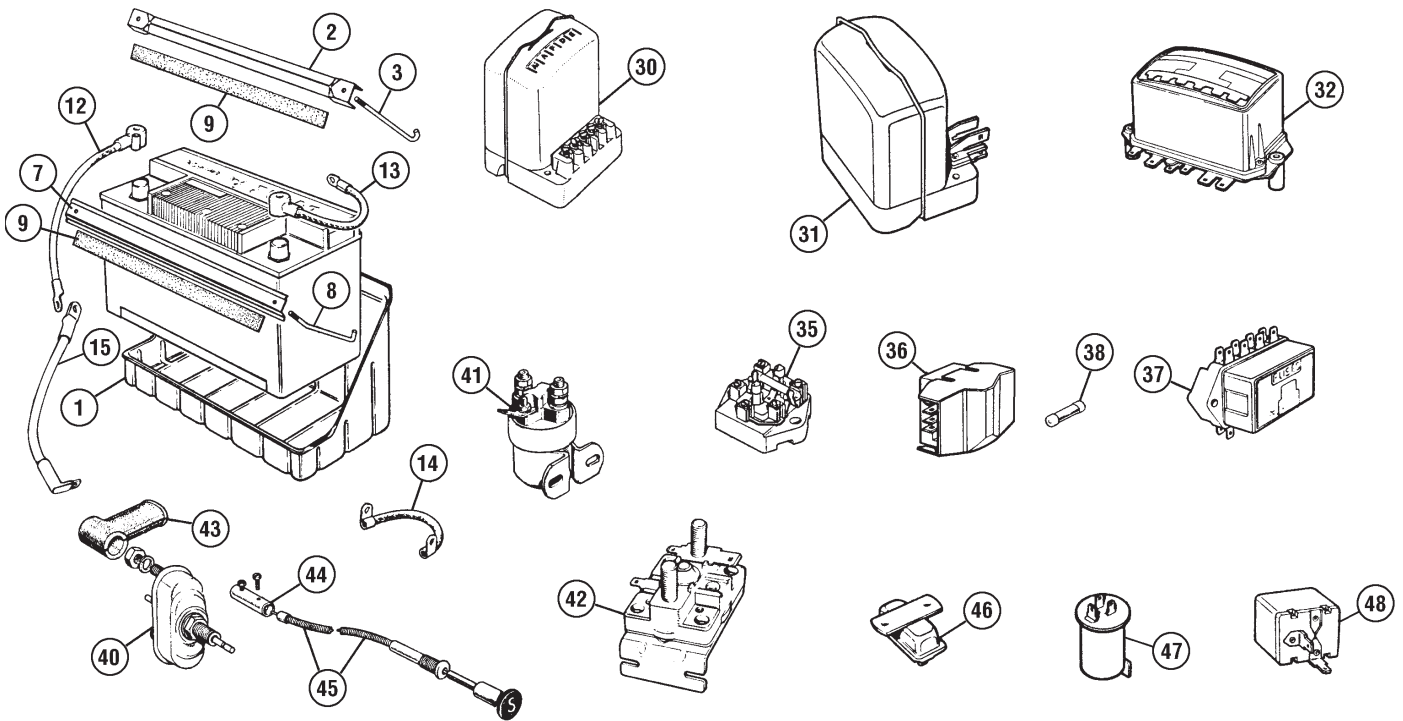

No.	Part No.	Price (each)	Description	Application	Qty. Req.
1	241-020	\$49.95	LINER, battery tray, 12"x7" battery	thru 1967	1
2	031-769	\$8.95	BRACKET, battery retaining	} 948, 1098 & 1275 (1967)	1
3	407-618	\$4.90	J-BOLT & NUT SET, 4 1/2"		1
7	473-185	\$6.85	BRACKET, battery retaining	} 1275 from 1968 & 1500	1
8	407-608	\$4.95	J-BOLT & NUT		2
9	473-115	\$1.95	PACKING		1
12	736-080	NA	BATTERY CABLE, to body	pos. ground cars	1
	736-100	\$24.95	BATTERY CABLE, to body	neg. ground cars	1
13	332-190	NA	BATTERY CABLE, to solenoid	neg. ground cars	1
		NA	BATTERY CABLE, to solenoid	pos. ground cars	1
14	332-070	\$10.15	GROUND STRAP, engine to body		1
15	332-170	\$14.95	CABLE, solenoid to starter	948, 1098 & 1275	1
	332-180	NA	CABLE, solenoid to starter	1500	1
30	142-000†	\$45.95	REGULATOR, screw terminal	948 & 1098	1
31	542-100†	\$45.95	REGULATOR, spade terminal	1098 & 1275	1
32	142-040†	\$31.95	REGULATOR, Lucas	} 1275	1
	142-045†	\$23.95	REGULATOR, replacement		1
† These regulators are used with generator systems only. Original application change-points are complicated - replace like for like.					
35	162-500	\$62.95	FUSE BOX	Sprite MkII, Midget MkI	1
36	560-100	\$17.95	FUSE BOX	from above thru 1967	1
37	162-510	\$29.95	FUSE BOX	} 1968-'80	1
	560-115	\$10.50	COVER for 162-510		1
38	146-700	\$0.65	FUSE 35 amp		A/R
40	145-800	\$38.95	STARTER SWITCH	Sprite MkII, Midget MkI	1
41	546-020	\$29.95	SOLENOID	from above thru 1967	1
42	546-151	NA	SOLENOID, Lucas	} 1968-'74	1
	546-152	\$20.95	SOLENOID, reproduction		1
	131-505	\$17.95	SOLENOID	1500	1
43	161-900	\$1.95	BOOT	all	2
44	161-500	\$5.45	COUPLING with screws	used with switch 145-800	1
45	331-630	\$15.95	CABLE, starter pull	Bugeye	1
	331-710	\$20.95	CABLE, starter pull, replacement	Sprite MkII, Midget MkI	1
46	131-550	\$20.95	VOLTAGE STABILIZER	1275 - 1500	1
47	141-750	\$12.95	FLASHER, turn signal, screw terminals	} 948 - 1098	1
	171-300	\$8.55	FLASHER, turn signal, spade terminals		} 1275 thru '67
48	141-740	\$8.30	FLASHER, turn signal	1275 from '68 thru 1500	1
	141-655	\$7.95	FLASHER, hazard (replacement)	1275, 1968-'71	1
	141-650	\$6.95	FLASHER, hazard	1275 from '72, 1500	1

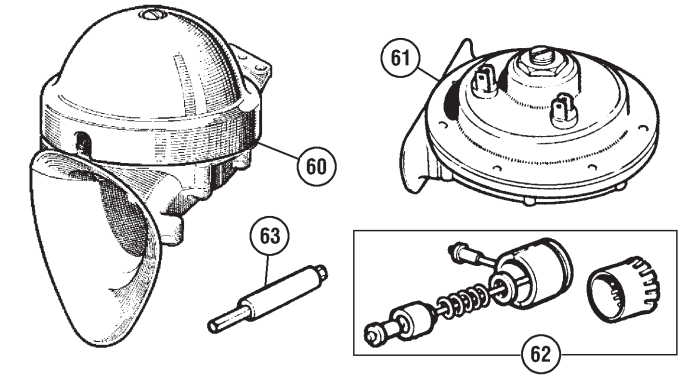

No.	Part No.	Price (each)	Description	Application	Qty. Req.
60	165-700*	\$77.95	HORN, Windtone, high note	} Bugeye, option	1
	165-800*	\$77.95	HORN, Windtone, low note		1
61	545-030	\$28.95	HORN, high note	} 1098 thru 1500	1
	545-020	\$28.95	HORN, low note		(option for earlier cars)
62	263-745	\$16.95	SLIP RING & HORN CONTACT		1
63	560-430	\$10.95	CONTACT, horn push	948	1
	263-750	\$12.95	CONTACT, horn push	1275 as fitted	1

* Sprite MkI-MkII and Midget MkI standard fitment was single horns of types no longer available. Bugeyes used #60 as options, while later 948cc cars used the 1098-1500 type as options.

Generators are suitable for either negative or positive ground systems providing they are polarized to suit the particular electrical system immediately after fitting. Bolt generator to engine, do not connect the cables to the "D" and "F" terminals, but proceed as follows:

1. Determine which battery terminal is ground.
2. Temporarily connect a length of wire to the battery positive terminal for negative ground systems, or to the negative terminal for positive ground systems.
3. Flick the other end of the wire several times against terminal "F". This serves to re-polarize the generator.
4. Remove temporary connection and connect the cables to the "D" and "F" terminals.



Generator & Starter

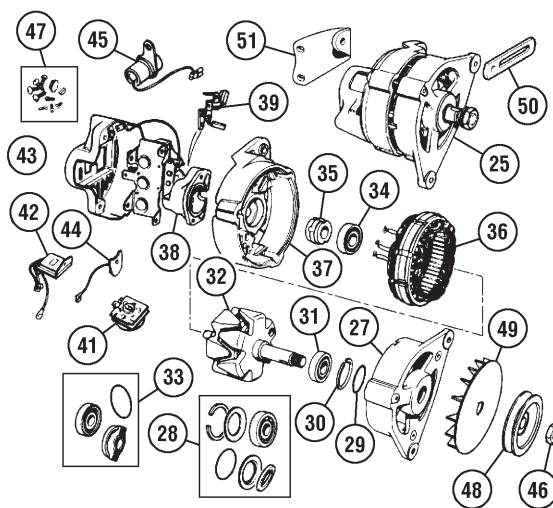
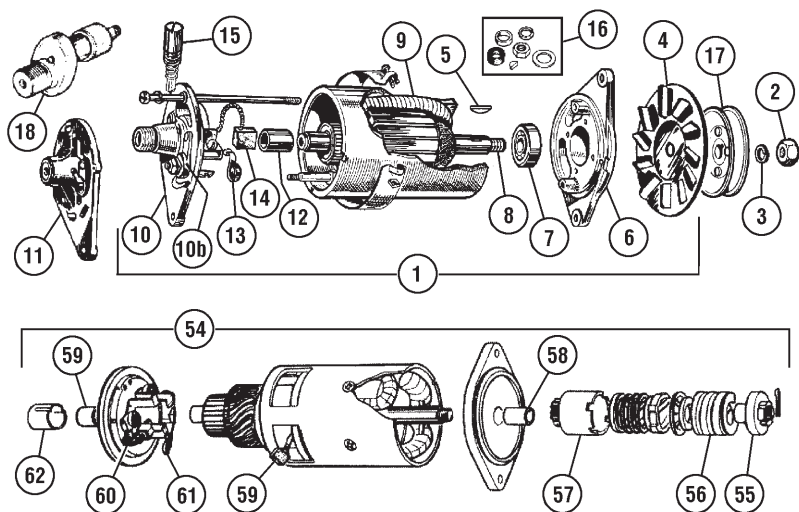

No.	Part No.	Price (each)	Description	Application	Qty. Req.
-----	----------	--------------	-------------	-------------	-----------

Generator, 1958-'61 (948 cc engines)

1	140-300	\$189.95	GENERATOR, new		1
2	310-310	\$1.35	NUT, armature shaft		1
3	324-050	\$0.20	LOCKWASHER		1
4	433-670	\$7.65	FAN (not incl. with generator)		1
5	327-030	\$0.75	KEY, armature shaft		1
6	147-300	NA	PLATE, drive end		1
7	125-100	\$9.25	BEARING, FRONT		1
8	162-600	NA	ARMATURE		1
9	NA	NA	FIELD COIL SET		1
10	147-500	NA	PLATE, commutator end		1
10b	147-020	\$2.95	INSULATOR, terminal		1
12	147-600	NA	BUSHING, rear		1
13	147-700	NA	SPRING SET, brushes		1
14	147-200	\$4.95	BRUSH SET		1
15	147-900	\$30.95	OILER		1
16	148-120	NA	SUNDRIES KIT (small parts package)		1
17	473-130	\$109.95	PULLEY		1
18	361-870	\$76.95	GEARBOX, tachometer drive		1

Generator, 1962-'71

1	140-200	\$89.95	GENERATOR, new		1
This replaces original generators Lucas #22258, 22742, 22775, and 22715.					
2	310-310	\$1.35	NUT		1
3	324-250	\$0.25	LOCKWASHER		1
4	539-000	NA	FAN (not incl. with generator)		1
5	327-030	\$0.75	WOODRUFF KEY, for pulley		1
6	147-310	\$21.95	BRACKET, driving end		1
7	125-100	\$9.25	BEARING, driving end		1
8	162-900	\$46.95	ARMATURE		1
9	560-070	NA	FIELD COIL SET		1
11	539-180	\$24.95	BRACKET, commutator end		1
12	147-600	NA	BUSH, commutator end		1
	539-190	\$1.70	OILER (internal)		1
13	549-030	NA	SPRING SET		1
14	147-250	\$3.40	BRUSH SET		1
17	473-130	\$109.95	PULLEY		1

Alternator, 1972-'80

25	130-000	\$149.95	ALTERNATOR, new (pulley & fan not included)		1
Note: The alternator supplied is the Lucas replacement for all originally fitted alternators. Numbers listed in the application column are the Lucas numbers for the original units.					
27	130-120	\$32.95	BRACKET, drive end		1
28	130-140	NA	BEARING KIT, drive end		1
29	130-450	NA	O-RING		1
30	130-455	NA	CIRCLIP		1
31	011-265	\$12.95	BEARING, drive end		1
32	130-160	NA	ROTOR ASSEMBLY		1
33	130-180	NA	BEARING SET, slip ring end		1
34	NA	NA	BEARING		1

No.	Part No.	Price (each)	Description	Application	Qty. Req.
-----	----------	--------------	-------------	-------------	-----------

35	130-215	NA	SLIP RING		1
36	130-190	NA	STATOR		1
37	130-210	NA	BRACKET, slip ring end		1
38	130-230	NA	BRUSH HOUSING ASS'Y.		1
39	130-235	\$3.40	BRUSH SET		1
41	130-250	\$12.40	RECTIFIER	23716	1
	130-260	NA	RECTIFIER	L23804, 23748	1
42	130-280	\$14.95	REGULATOR	23716	1
	130-290	\$49.95	REGULATOR	L23804, 23748	1
43	130-320	\$6.80	COVER		1
44	130-345	NA	SURGE PROTECTOR		1
45	130-350	NA	CAPACITOR		1
46	310-810	\$2.50	NUT		1
47	130-360	NA	SUNDRIES KIT		1
48	130-370	\$19.95	PULLEY	1275 engines	1
	539-090	\$14.95	PULLEY	1500 engines	1
49	130-400	\$24.95	FAN		1
50	460-330	\$9.00	LINK, adjusting	} 1275 engines	1
51	130-115	\$16.95	BRACKET, rear		1

Starter

54	140-400	\$131.95	STARTER, new reproduction		1
	541-540	\$79.95	STARTER, rebuilt, exchange		1
		\$20.00	CORE CHARGE FOR 541-540 STARTER		

Note: Three different starters were originally fitted: Lucas #25022, 25079, and 25149. All are interchangeable with each other, but differ in some of their internal parts. The starter supplied replaces all three.

55	150-500	\$25.95	NUT	25022	1
	549-625	NA	CLIP, used in place of nut	} 25079, 25149	1
		NA	CUP for clip		1
56	148-200	\$8.85	SPRING, main		1
57	148-800	\$34.95	PINION & SLEEVE	25022	1
	549-635	\$35.95	PINION & SLEEVE	25079, 25149	1
58	148-600	\$2.40	BUSH, driving end	25022	1
	148-610	\$1.95	BUSH, driving end	25079	1
	549-695	NA	BUSH SET (both bushes)	25149	1
59	148-500	\$1.95	BUSH, commutator end	25022	1
	131-325	\$1.05	BUSH, commutator end	25079	1
60	149-000	\$6.70	BRUSH SET (rectangular)	25022, 25079	1
	149-010	\$6.45	BRUSH SET (triangular)	25149	1
61	149-100	NA	SPRING SET, brushes	25022	1
	149-110	NA	SPRING SET, brushes	25079	1
62	149-800	NA	CAP, end shaft	25022	1

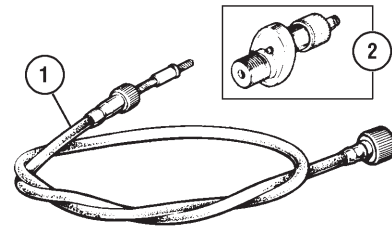
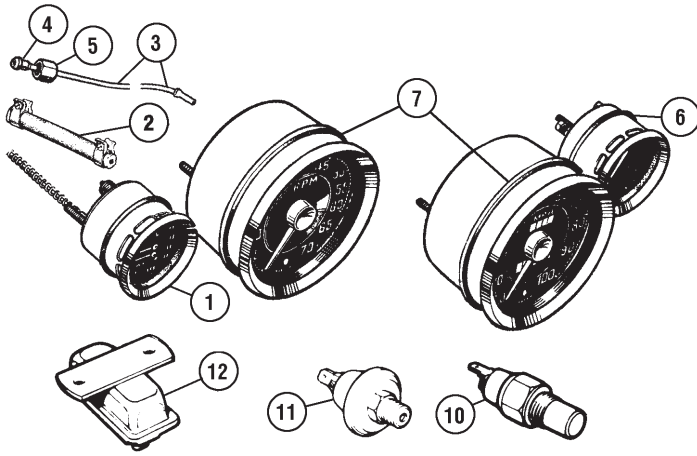

No.	Part No.	Price (each)	Description	Application	Qty. Req.
-----	----------	--------------	-------------	-------------	-----------

Note: Moss does not stock gauges for Spridgets other than those listed. Please inquire to MO-MA, 1321 2nd St. NW, Albuquerque, NM 87102 (505)766-6661, or West Valley Instruments, 19314 Van Owen, Reseda, CA 91335 (818)758-9500

1	361-761	\$152.95	COMBINATION GAUGE (This replacement gauge is similar to all listed below, but not identical to any - a perfect gauge to use when the "correct" one is not available.)	replacement type	1
	361-760	NA	COMBINATION GAUGE	AH Bugeye only	1
	361-770	NA	COMBINATION GAUGE	AH MkII thru (c)24731	1
	361-780	NA	COMBINATION GAUGE	{ MG MkI AH MkII from (c)24732	1
	361-790	NA	COMBINATION GAUGE	{ MG MkII & III to (c)60440 AH MkIII & IV to (c)72033	1
	361-800	NA	COMBINATION GAUGE	{ MG MkIII (c)60441 to 105500 AH MkIV (c)72034 on	1
	361-810	\$160.95	COMBINATION GAUGE	MG MkIII (c)105501 to 154100	1
	361-820	NA	COMBINATION GAUGE	{ MG MkIII 1500 (c)154101 to 200000	1
2	361-765	\$10.90	HOSE, oil pressure, w/clips		1
3		NA	PIPE ASS'Y., engine to hose*	} 948 through 1275	1
4	376-460	\$4.70	NIPPLE*		1
5	376-400	\$3.95	NUT*		1
NOTE: Nipple #4 and Nut #5 fit on the engine end of the pipe. You must find a length of tubing locally, and solder the tube to the nipple. This nipple and nut will not work on the gauge pipe.					
6	280-870	\$1.95	SEALING RING, 2" gauges		A/R
7	280-890	\$2.95	SEALING RING, 4" gauges		2
10	071-241	\$9.60	TRANSMITTER, temp gauge	1500 from (c)200001-on	1
11	131-585	\$5.30	SWITCH, oil pressure warn. light	1500 except CA	1
	131-595	NA	SWITCH, oil pressure warn. light	1500 CA only	1
12	131-550	\$20.95	VOLTAGE STABILIZER	1275 & 1500	1

No.	Part No.	Price (each)	Description	Application	Qty. Req.
-----	----------	--------------	-------------	-------------	-----------

Cables, Speedo & Tach

1	021-381	\$16.95	SPEEDOMETER CABLE	948 & 1098	1	
	331-300	\$18.95	SPEEDOMETER CABLE	1275	1	
	331-590	\$18.95	CABLE, gearbox to interval counter	} 154101- 188000	1	
	331-610	\$16.95	CABLE, interval counter to speedo		1975 - '76 except CA	1
	331-600	NA	CABLE, gearbox to 1st interval counter	} (c)154101-180000	1	
	331-605	NA	CABLE, 1st to 2nd interval counter		1975 - '76 CA only	1
	331-610	\$16.95	CABLE, 2nd interval counter to speedo		1	
	331-585	\$18.95	CABLE, gearbox to speedo	{ (c)1880001 - 200000 1977 except CA	1	
	331-590	\$18.95	CABLE, gearbox to interval counter	} (c)1880001 - 200000	1	
	331-610	\$16.95	CABLE, interval counter to speedo		1977 CA only	1
	331-590	\$18.95	CABLE, gearbox to interval counter	} (c)200001 - 212000	1	
	331-615	NA	CABLE, interval counter to speedo		1978 CA only	1
	331-595	\$23.95	CABLE, gearbox to speedo	{ (c)200001 on 1978 on except CA	1	
	331-595	\$23.95	CABLE, gearbox to speedo	{ (c)212001 on 1979 - '80 CA only	1	
2	732-000	\$21.95	TACHOMETER CABLE	} 948	1	
	361-870	\$76.95	GEARBOX, tach		1	

Dashboard

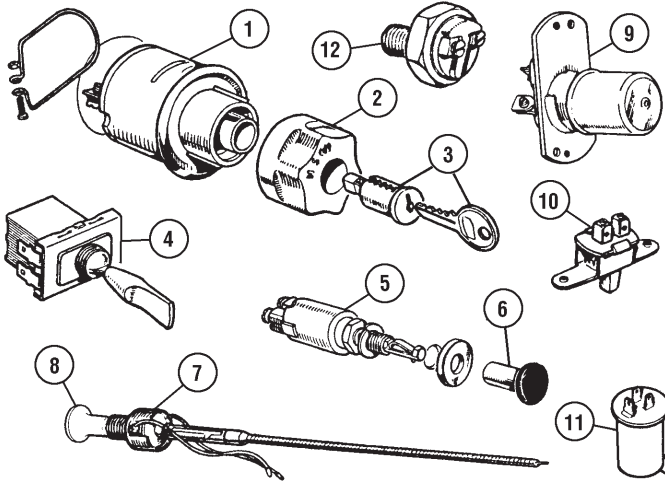
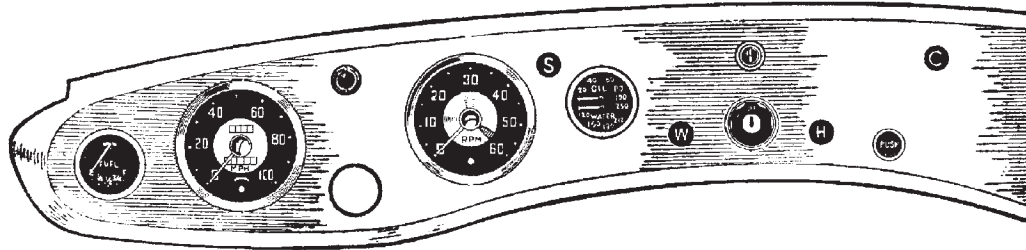

No.	Part No.	Price (each)	Description	Application	Qty. Req.
Bugeye					
1	140-535	\$59.95	COMBINATION SWITCH. "Classic Gold" reproduction		1
2	140-515	\$15.95	KNOB, light & ignition switch		1
3	163-500	\$13.95	LOCK BARREL, with 2 keys		1
4	141-200	\$33.95	DIRECTIONAL SWITCH		1
5	162-100	\$24.95	WIPER SWITCH (supplied with plain knob)		1
6	331-075	\$10.30	KNOB, wiper switch		1
7	331-690	NA	HEATER CABLE & SWITCH (without knob)		1
8	331-085	\$9.95	KNOB, heater cable		1
9	140-900	\$41.95	SWITCH, high beam		1
10	140-520	\$49.95	SWITCH, panel lamp		1
11	141-750	\$12.95	FLASHER		1
12	141-700	\$9.95	SWITCH, brake light	screw connectors	1

Note: Starter switch and cable are listed on page 67.

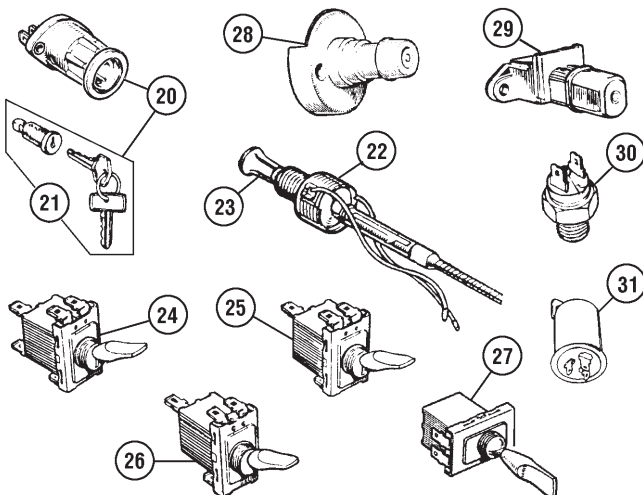
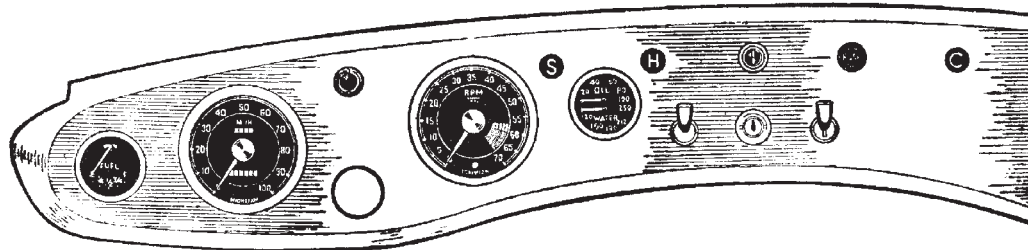

No.	Part No.	Price (each)	Description	Application	Qty. Req.
Sprite MkII, Midget MkI					
20	169-108	\$43.95	SWITCH, ignition		1
21	163-500	\$13.95	BARREL, with 2 keys		1
22	331-695	NA	HEATER SWITCH & CABLE	(without knob)	1
23	331-085	\$9.95	KNOB, heater cable		1
24	141-530	\$29.95	SWITCH, panel lamps		1
25	141-530	\$29.95	WIPER SWITCH		1
26	141-230	\$46.95	HEADLAMP SWITCH		1
27	141-200	\$33.95	SWITCH, turn signal		1
28	NA		SWITCH, high beam	(Use #29, 542-130 as replacement)	1
29	542-130	\$54.95	SWITCH, high beam	(replacement)	1
30	542-110	\$9.95	SWITCH, brake light		1
31	141-750	\$12.95	FLASHER UNIT	screw connectors	1

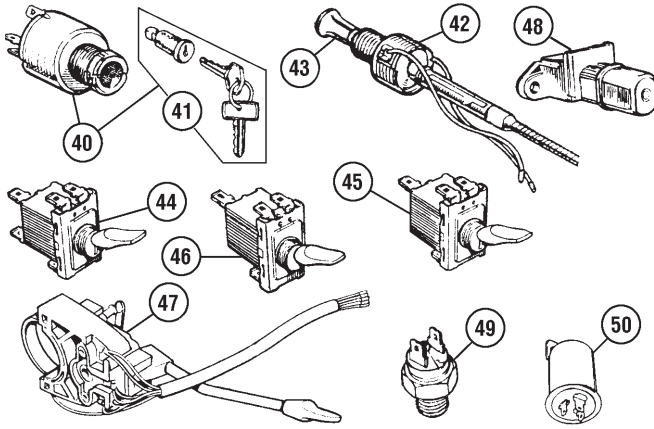
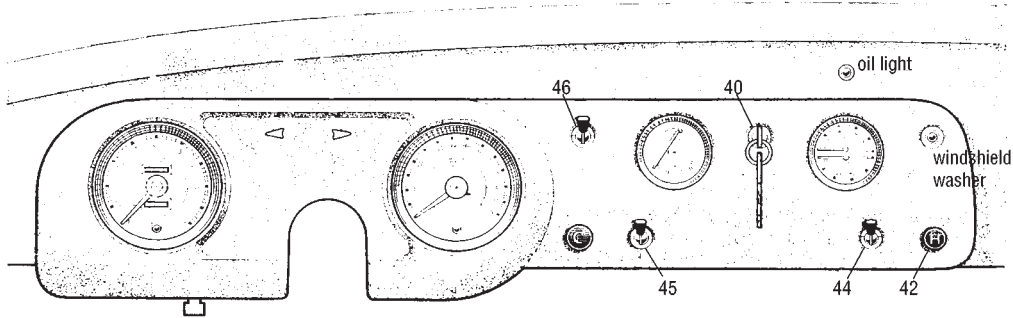

No.	Part No.	Price (each)	Description	Application	Qty. Req.
Sprite MkIII-MkIV, Midget MkII-III thru 1967					
40	542-070	\$36.95	SWITCH, ignition & starter	Sprite MkIII, Midget MkII	1
41	163-500	\$13.95	BARREL, with 2 keys		1
42	331-695	NA	HEATER SWITCH & CABLE (without knob)	thru 1965	1
	331-705	NA	HEATER SWITCH & CABLE (without knob)	1966 - '67	1
43	331-085	\$9.95	KNOB, heater cable		1
44	141-530	\$29.95	SWITCH, panel lamps		1
45	141-530	\$29.95	WIPER SWITCH		1
46	141-230	\$46.95	HEADLAMP SWITCH		1
47	141-770	\$88.95	SWITCH, turn signal		1
48	542-130	\$54.95	SWITCH, high beam		1
49	542-110	\$9.95	SWITCH, brake light		1
50	171-300	\$8.55	FLASHER UNIT	spade connectors	1

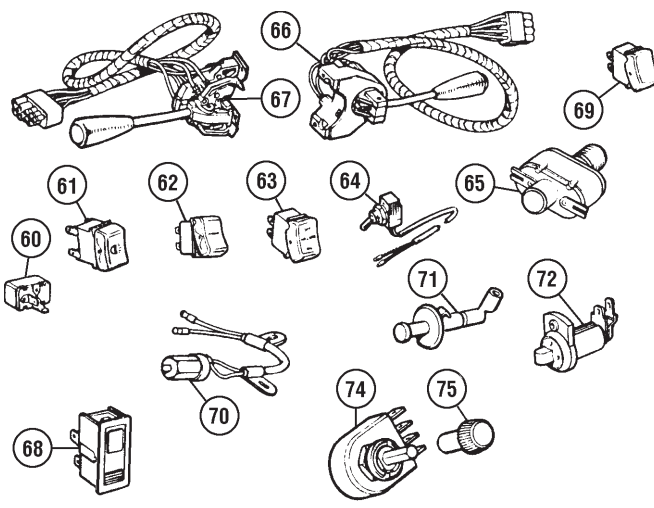
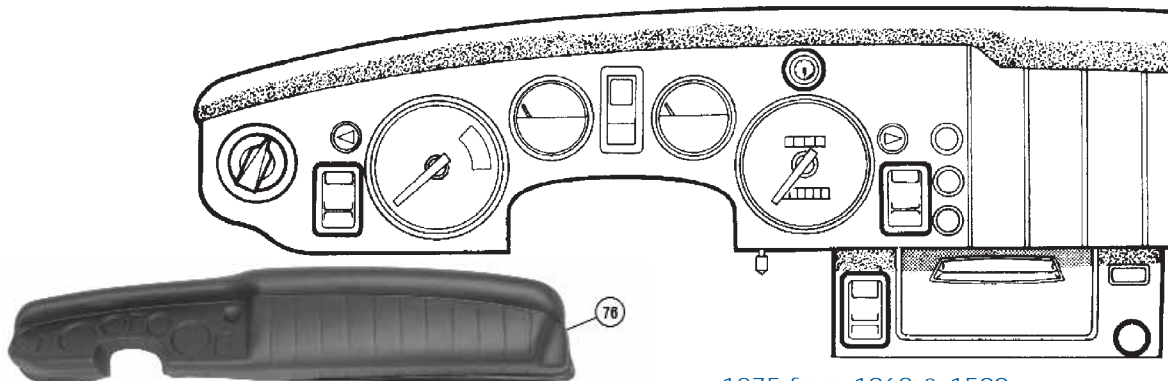

1275 from 1968 & 1500					
60	141-740	\$8.30	FLASHER UNIT		1
61	141-260	\$27.95	SWITCH, headlamp on/off	1275 to (c)123750	1
	141-275	\$23.95	SWITCH, headlamp on/off	1275 from (c)123751-1500	1
62	141-250	\$27.95	SWITCH, heater blower	1275	1
	141-270	\$23.95	SWITCH, heater blower	1500	1
63	140-540	\$32.95	SWITCH, hazard warning, replacement	1275, 1968 - '72	1
	141-635	\$38.95	SWITCH, hazard warning	1275 from '73, all 1500	1
64	140-520	\$49.95	SWITCH, panel lamp	1275	1
65	181-980	\$23.95	SWITCH, brake light	1275 & 1500	1
66	141-825	\$98.95	SWITCH, wiper/washer	1275 thru '73	1
	141-845	\$123.95	SWITCH, wiper/washer	1275, 1500 '74 thru '77	1
	141-855	\$89.95	SWITCH, wiper/washer	1500 '78 - '79	1
67	141-810	\$88.95	SWITCH, directional, horn, dimmer	1275, 1968-'70	1
	141-830	\$65.95	SWITCH, directional, dimmer	1275, 1971 - '73	1
	141-840	\$63.95	SWITCH, directional, dimmer	1275, 1500, 1974 - '77	1
	141-850	\$94.95	SWITCH, directional, horn, dimmer	1500, 1978 - '79	1
68	140-550	NA	SWITCH, brake check		1
69	162-170	\$18.95	SWITCH, fog, accessory	1275	1
70	141-020	NA	SWITCH, reverse lamp		1
	542-400	NA	SWITCH, reverse lamp	1275 - 1500, 1970 - '75	1
	542-410	\$10.95	SWITCH, reverse lamp	1500, 1976 on	1
71	131-620	\$13.95	SWITCH, trunk	1275, 1976 on	1
72	131-640	\$5.65	SWITCH, courtesy light	1971-on	1
	182-410	\$29.95	SWITCH, handbrake		1
74	140-620	NA	SWITCH, panel lamp rheostat	1500	1
75	140-630	NA	KNOB		1
76	453-815	\$249.95	DASHBOARD COVER, padded	1968-'74	1
	453-816	\$249.95	DASHBOARD COVER, padded	1975-'79	1

Note: Steering column mounted ignition switches are listed on page 33.

LOCAL & OVERSEAS: 805-681-3400
 FAX: 805-692-2525 www.mossmotors.com



• replacement, with chrome bezel

Weather Protection

Sun-Fast Tonneau Covers

Sun-Fast is an acrylic canvas which is soft and flexible over a wide temperature range, yet is waterproof, and highly resistant to sagging, billowing, shrinking and fading. (These are made to order, so please allow 6 to 10 weeks for delivery.)

Vinyl Tonneau Covers

Tonneau covers are the time tested method of protecting your car's interior. Our tonneau covers incorporate the finest materials and workmanship and are supplied complete with hardware (fasteners on car body not included).

241-270	\$253.95	TONNEAU COVER, black	948 Bugeye
241-280	\$269.95	TONNEAU COVER, black	948 & 1098, 1961-'64
241-285	\$305.95	TONNEAU COVER, black	1965 - '66
<hr/>			
241-290	\$288.95	TONNEAU COVER, black no headrest pockets	} 1275 from 1967
<hr/>			
241-300	\$301.95	TONNEAU COVER, black with headrest pockets	} 1275 & 1500

241-271	\$546.95	TONNEAU COVER, black	} 948 Bugeye
241-272	\$546.95	TONNEAU COVER, tan	
<hr/>			
241-281	\$573.95	TONNEAU COVER, black	} 948 & 1098, 1961-'66
241-282	\$573.95	TONNEAU COVER, tan	
<hr/>			
241-291	\$590.95	TONNEAU COVER, black	} 1275 from 1967 no headrest pockets
241-292	\$590.95	TONNEAU COVER, tan	
<hr/>			
241-301	\$617.95	TONNEAU COVER, black	} 1275 & 1500 with headrest pockets
241-302	\$617.95	TONNEAU COVER, tan	

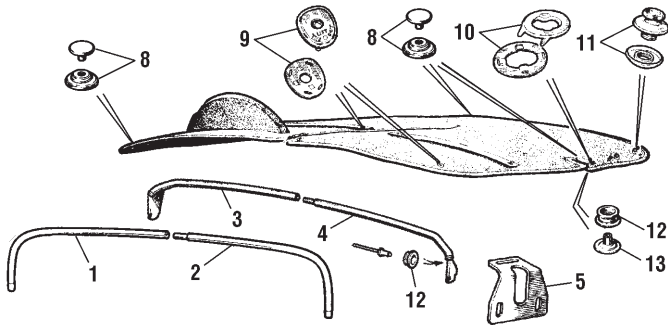

No.	Part No.	Price (each)	Description	Application	Qty. Req.
-----	----------	--------------	-------------	-------------	-----------

Tonneau Cover Fittings

1	453-605	\$44.95	TONNEAU BAR, R/H	} Sprite MKII, Midget MKI	1
2	453-635	\$44.95	TONNEAU BAR, L/H		1
<hr/>					
	453-910	\$29.95	TONNEAU BAR, R/H	} Sprite MKIII, Midget MKII	1
	453-915	\$29.95	TONNEAU BAR, L/H		1
<hr/>					
3	453-920	\$45.95	TONNEAU BAR, R/H	} 1275 - 1500 1967-'80	1
4	453-925	\$45.95	TONNEAU BAR, L/H		1
5	402-565	\$20.95	BRACKET, tonneau bar		2
<hr/>					
8	227-108	\$0.75	*SNAP ASS'Y., female		A/R
9	226-308	\$1.25	*FASTENER, "Lift the Dot"		A/R
10	227-408	\$0.50	*EYELET		A/R
11	227-600	\$6.50	*FASTENER, "Tenax" (genuine "Tenax" brand)		A/R
12	226-720	\$0.55	*SNAP, male		A/R
13			NA *SNAP BASE		A/R

* Quantities and applications vary - not all are used on all cars.

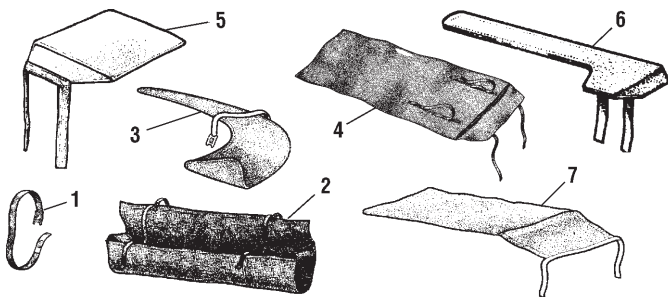

Stowage Bags

1	385-955	\$9.70	STRAP, top stowage, replacement	1958-66	2
2	242-575	NA	TOP STOWAGE BAG	Sprite MkII, Midget MkI	1
3	242-595	NA	TOP FRAME STOWAGE BAG	Sprite MkII-III, Midget MkII-II	1
4	242-585	\$123.95	SIDE CURTAIN STOWAGE BAG		1
5	242-605	\$34.95	TONNEAU COVER STOWAGE BAG		1
6	242-565	\$28.95	TONNEAU BAR STOWAGE BAG	1967-80	1
7	242-590	NA	TOP COVER STOWAGE BAG	1967-80	1

1	386-980	\$9.85	SNAP FASTENING TOOL		1
2	387-055	\$0.75	FITTING KEY, Tenax fastener		1

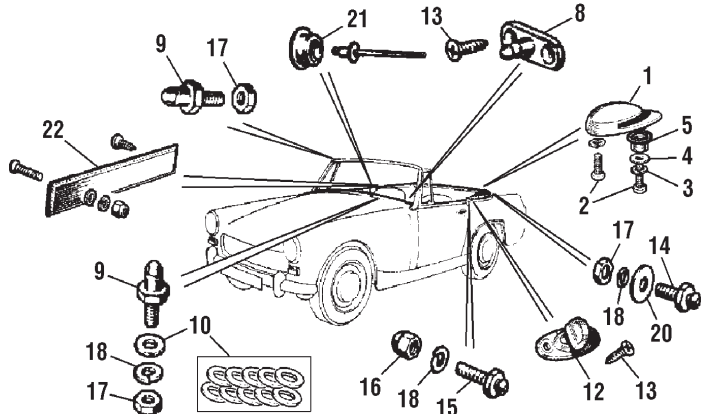

No.	Part No.	Price (each)	Description	Application	Qty. Req.
-----	----------	--------------	-------------	-------------	-----------

Body Fittings

1	470-747	\$4.95	RETAINER, top & tonneau cover	} all through 1966	2
2	323-455	\$0.55	SCREW		4
3	324-010	\$0.15	LOCKWASHER		4
4	324-990	\$0.55	WASHER, plain		2
5	470-757	\$1.95	WASHER, cup		2
<hr/>					
8	226-630	\$1.95	STUD, "Lift-the-Dot", rear heelboard	all except Bugeye	4
9	226-600	\$1.35	STUD, "Lift-the-Dot"		A/R
10	315-168	\$1.45	WASHER SET, nylon (pack of 10), protects paint		A/R
12	227-500	\$1.40	TURNBUCKLE		A/R
13	323-600	\$0.15	SCREW		A/R
14	227-700	\$2.25	STUD, "Tenax" (3/8" long stud)	most applications	A/R
<hr/>					
15	227-010	\$1.70	STUD, "Tenax" (5/8" long stud)	} top of "B" posts '64-'80	2
16	311-045	\$1.35	DOME NUT, chrome		2
<hr/>					
17	310-040	\$0.15	NUT, for studs		A/R
18	324-010	\$0.15	LOCKWASHER		A/R
20		NA	WASHER, chrome		2
21	226-720	\$0.55	MALE SNAP		A/R
<hr/>					
22	242-215	\$5.85	VELCRO STRIP	1967-'80	2

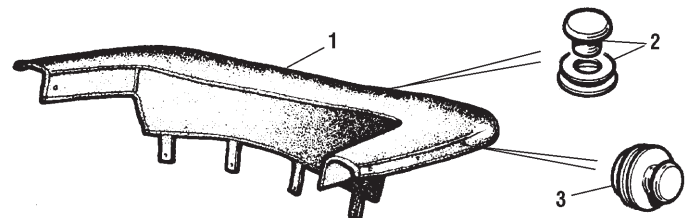

Top Cover

1	241-525	\$299.95	TOP COVER, black	1969-'80	1
2	227-108	\$0.75	SNAP ASS'Y, female		A/R
3	227-600	\$6.50	TENAX FASTENER (genuine "Tenax" brand)		A/R

moss MOSS MOTORS, LTD. TOLL-FREE ORDERS **1-800-667-7872**



Convertible Tops

Robbins high quality replacement tops duplicate the original tops in almost all respects. Sun-Fast is an acrylic canvas which is soft and flexible over a wide temperature range, yet is waterproof, and highly resistant to sagging, billowing, shrinking and fading. (Sun-Fast tops are made to order, so please allow 6 to 10 weeks for delivery.)

Tops are supplied with all snaps and fasteners, but do not include the header rail (except where noted), body hardware or rear anchor bar.

SPRITE-MIDGET

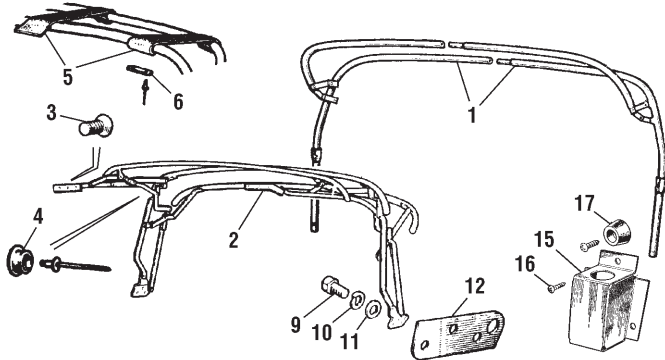

No.	Part No.	Price (each)	Description	Application	Qty. Req.	
Top Frames						
	400-630	\$299.95	TOP FRAME ASSY.	Sprite MKI	1	
1	400-648	\$299.95	TOP FRAME ASSY. (2 piece)	Sprite MKII, Midget Mkl	1	
	400-658	\$329.95	TOP FRAME ASSY. (2-piece)	Sprite MkIII, Midget MkII	1	
2	400-680	\$369.95	TOP FRAME ASSY. (permanent mount)	1967-'80	1	
3	323-280	\$0.95	SCREW, frame to header rail		4	
4	226-720	\$0.55	MALE SNAP		2	
5	NA		WEBBING KIT, top frame		1	
6	402-545	NA	PLATE, securing webbing		6	
9	322-290	\$0.45	BOLT, top frame to body, short		2	
	320-695	\$0.75	BOLT, top frame to body, long		4	
10	365-730	\$0.20	LOCKWASHER		6	
11	365-720	\$0.30	WASHER, plain		6	
12	402-595	\$0.95	PACKING PIECE, top frame to body		2	
15	402-555	\$20.95	BRACKET, top frame stowage		Bugeye only	2
16	314-070	\$0.35	SCREW			6
17	NA		BUFFER	2		



Side Curtains

Fit your Sprite or Midget with a set of our factory style side curtains, complete with sealing strips, brackets and screws. Just like the original, these side curtains look great while keeping out the wind, the cold and the rain.

259-678	\$459.95	Side Curtain Set, Complete	1
259-675	\$38.95	Bracket Set with nuts & bolts	1
282-455	\$26.95	Outer Seal, L/H	1
282-465	\$26.95	Outer Seal, R/H	1
401-690	\$8.25	Screws, side curtain mounting	4

242-180	\$284.95	TOP, black vinyl	Bugeye, studs on w/s frame	1
242-181	\$632.95	TOP, black Sun-Fast		1
242-182	\$632.95	TOP, tan Sun-Fast		1
242-185	\$284.95	TOP, black vinyl	Bugeye, bar mount	1
242-186	\$632.95	TOP, black Sun-Fast		1
242-187	\$632.95	TOP, tan Sun-Fast		1
242-190	\$288.95	TOP, black vinyl	Sprite MkII, 948, 1098	1
242-191	\$621.95	TOP, black Sun-Fast	Midget Mkl, 948, 1098	1
242-192	\$621.95	TOP, tan Sun-Fast	(cars with side curtains)	1
242-195	\$279.95	TOP, black vinyl	Sprite MkIII, 1098	1
242-196	\$588.95	TOP, black Sun-Fast	Midget MkII 1098	1
242-197	\$588.95	TOP, tan Sun-Fast	(cars with wind-up windows)	1
242-175	\$283.95	TOP, black vinyl,	Sprite MkIV 1275	1
242-176	\$588.95	TOP, black Sun-Fast	Midget MkIII 1275	1
242-177	\$588.95	TOP, tan Sun-Fast	8 Tenax studs 1967-'69	1
242-200	\$281.95	TOP, black vinyl	Sprite MkIV, Midget MkIII 1275	1
242-201	\$588.95	TOP, black Sun-Fast	Midget 1500	1
242-202	\$588.95	TOP, tan Sun-Fast	6 Tenax studs, 1969 on	1
242-205	\$589.95	TOP, with header rail (black vinyl)	Sprite/Midget 1969-on	1

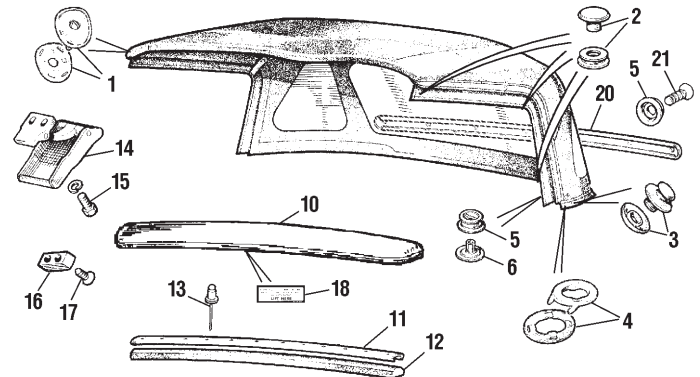

Top Fittings

1	226-308	\$1.25	*FASTENER, "Lift-the-Dot"	A/R
2	227-108	\$0.75	*SNAP ASSEMBLY, female	A/R
3	227-600	\$6.50	*FASTENER, "Tenax" (genuine "Tenax" brand)	A/R
4	227-408	\$0.50	*EYELET	A/R
5	226-720	\$0.55	*SNAP, male	A/R
6	226-900	\$0.50	SNAP BASE	A/R

*Not all used on all cars - quantity and application vary.

10	400-695	NA	HEADER RAIL	1967-'80	1
11	453-930	\$9.95	RETAINER, header rail seal		1
12	453-610	\$18.95	HEADER RAIL SEAL		1
13	325-288	\$3.70	RIVET SET, 15 pcs. retainer to rail		1
14	406-230	\$32.95	LATCH, header rail		2
15	466-385	\$0.95	BOLT, header rail latches		4
16	406-260	\$1.95	PAD, header rail		2
17	323-635	\$0.35	SCREW		4
18	408-555	\$2.95	LABEL, header rail		1
20	400-670	\$28.95	RETAINING STRIP		1
21	314-310	\$0.50	SCREW, retaining strip		7

Interior Products

Restore your Sprite or MG Midget to original specifications with British made reproduction upholstery kits. With duplicated original patterns, vinyls, and even dielectrically welded seams where appropriate, your car will look factory new. Our seat and panel kits are complete and straightforward to install. The seat kits (see pages 56-57) include squab and cushion covers along with seat back extension covers where appropriate. The panel kits include sufficient vinyl to cover your dash panel and cockpit as required, new footwell boards, gear-box tunnel boards, inner sill boards, door pocket boards and rear quarter panels. **Free sample cards are available: Upholstery #878-160, Carpet #878-360.**

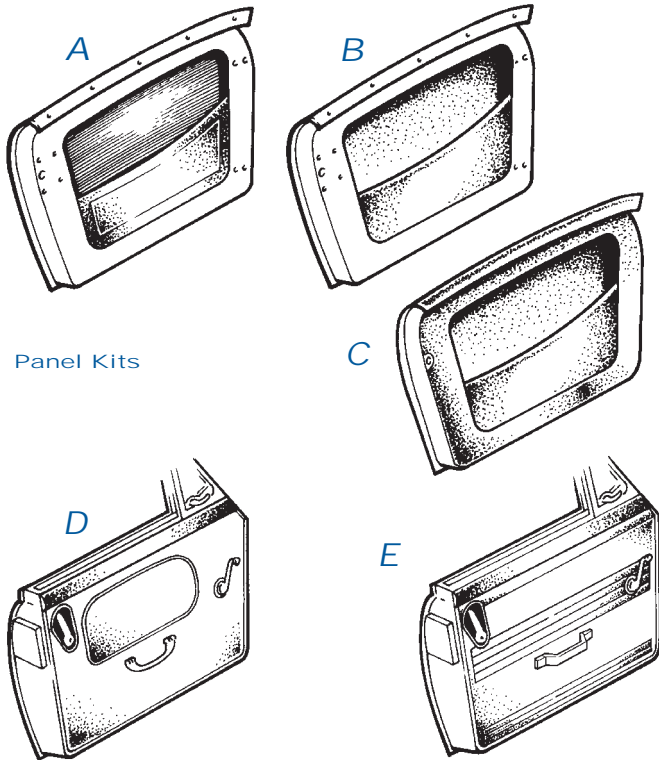
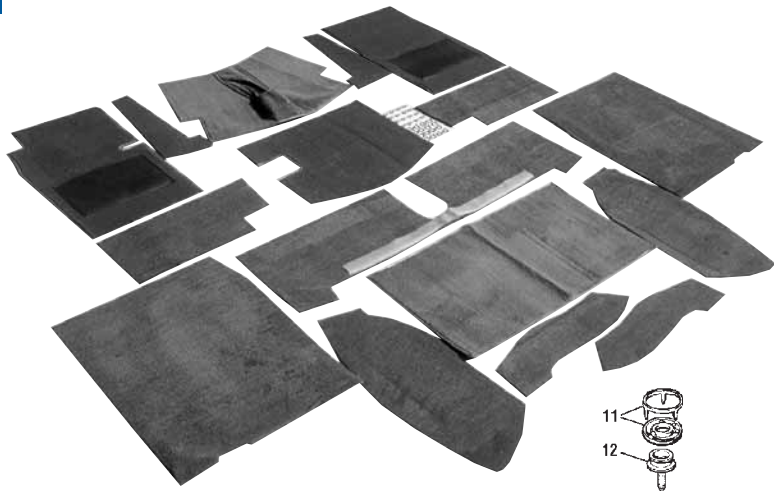

Panel Kits

Panel Kits		approx. model yr.	Black	Red	Blue	
A	Bugeye Sprite	1958-'60	645-500	645-510	645-520	\$269.95
B	948 Sprite MkII 948 Midget MkI	1961-'62	645-540	645-550	645-560	\$349.95
C	1098 Sprite HAN7 Midget GAN2	1963	645-620	645-630	645-640 (Navy)	\$419.95
D	1098 Sprite HAN8 Midget GAN3	1964-'66	645-570	645-580	645-585 (Light Blue)	\$426.95
			Black with Black Piping	Black with White Piping	Red with White Piping	
D	1275 Sprite HAN9 1275 Midget GAN4	1967-'69	645-660	645-670	645-680	\$419.95
			Black	Navy	Autumn Leaf	
E	1275 Midget GAN5 and 1500 Midget GAN6	1970-'80	645-700	645-710	645-720	\$282.95

Typical Panel Kit (style D illustrated)

1	317-070	\$0.45	PANEL CLIP
2	323-460	\$0.40	PANEL SCREW
3	323-985	\$0.55	CUP WASHER

1966-'80

26
A/R
A/R

No.	Part No.	Price (each)	Description	Application	Qty. Req.
Carpet Sets					
242-530	\$276.95	CARPET SET, black	} Side Curtain Sprite & Midget	1	
242-540	\$276.95	CARPET SET, red		1	
242-550	\$276.95	CARPET SET, blue		1	
242-560	\$279.95	CARPET SET, black	} Sprite & Midget with wind-up windows	1	
242-570	\$279.95	CARPET SET, red		1	
242-580	\$279.95	CARPET SET, autumn leaf		1	
11	226-338	\$1.55	"VELTEX" CARPET RING ASS'Y.		A/R
12	226-800	\$0.55	SNAP & SCREW		A/R

Rubber Floor Mat Sets

Protect your carpets from damage, while giving your interior added good looks with our heavy duty black ribbed rubber mats. Late mats are embossed with Midget or Sprite logo.



241-870	\$29.95	Sprite/Midget with side curtains (no logo) (Can be used with aluminum frame cover set #240-510)
241-880	\$29.95	Sprite, cars with roll-up windows
241-860	\$29.95	Midget, cars with roll-up windows

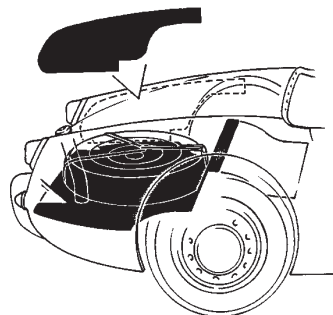

Bugeye "Trunk" Liner Set

Dress up the dark chasm behind your seats with a trunk liner set from Moss. Kit includes hardura trunk floor covering, and two side panels. Available in black only.

242-500 \$73.95



MOSS MOTORS, LTD.
TOLL-FREE ORDERS

1-800-667-7872

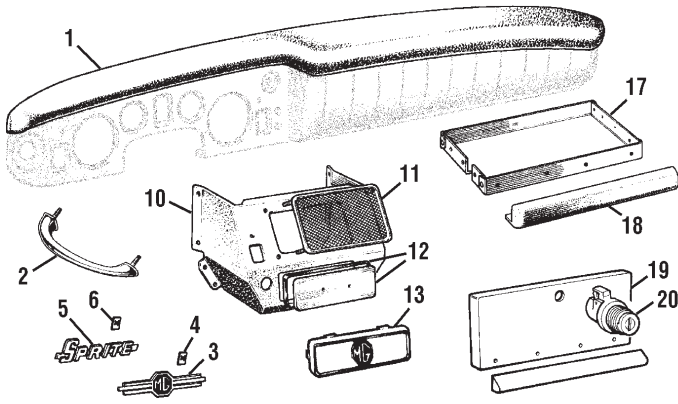

No.	Part No.	Price (each)	Description	Application	Qty. Req.
-----	----------	--------------	-------------	-------------	-----------

Dashboard Fittings

1	453-950	\$49.95	DASH TOP COVER	1968-'80	1
Fully molded black ABS vinyl dash pad quickly and easily glues on the top of your existing dash, making even badly suncracked dashes look new again. Comes complete with adhesive and installation instructions.					
	633-690	\$43.95	GRAB HANDLE, dashboard	Spite MKI, MKII	1
3	472-050	\$10.65	MG BADGE	} Midget (as fitted)	1
4	326-520	\$0.20	SPIRE NUT		2
5	470-615	\$19.95	SPRITE BADGE	} Sprite MKIII, MKIV	1
6	326-510	\$0.15	SPIRE NUT		2
10	453-810	\$189.95	RADIO CONSOLE	1966-80	1
11	233-835	\$76.95	SPEAKER SCREEN, chrome	1966-74	1
	233-855	NA	SPEAKER SCREEN, black	1975-80 (alt. to above)	1
12	472-078	\$27.95	RADIO BLANKING PLATE SET	1966-76	1
13	472-035	\$10.95	RADIO BLANKING PLATE	1977-80 Midget	1
17	240-830	NA	PARCEL SHELF	1966-72	1
18	240-840	NA	PAD, parcel shelf		1
19		NA	GLOVE BOX DOOR	} 1972-80	1
20	234-400	\$27.95	GLOVE BOX LOCK with 2 keys		1

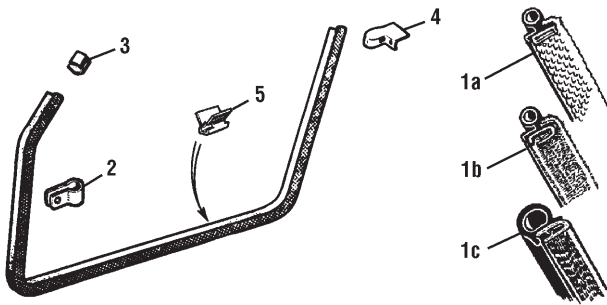

Door Seal & Finisheers

1a	249-800	\$16.75	DOOR SEAL, black woven fabric	} orig. type, 1958-'69 sold per yard	A/R*
	249-810	\$15.60	DOOR SEAL, red woven fabric		A/R*
1b	249-609	\$19.95	DOOR SEAL, black velour	} alt. type, 1958-'69 sold per yard	A/R*
	249-695	\$19.95	DOOR SEAL, red velour		A/R*
	249-857	\$19.95	DOOR SEAL, blue velour		A/R*
1c	259-907	\$6.25	DOOR SEAL, black vinyl	} orig. type, 1970-'80 sold per foot	A/R*

*Note: Cars through 1965 require 67" of door seal per door. Later cars need 60".

2		NA	CLIP, door seal front	Sprite Mkl, II, Midget Mkl	2
3	240-530	\$3.45	CLIP, door seal front end	} Sprite from MkIII (1275) Midget from MkII (1275)-on	2
4	240-545	\$10.95	FINISHER, L/H rear		1
	240-540	\$10.95	FINISHER, R/H rear		1
5	667-425	\$0.45	CLIP, door seal to flange		20

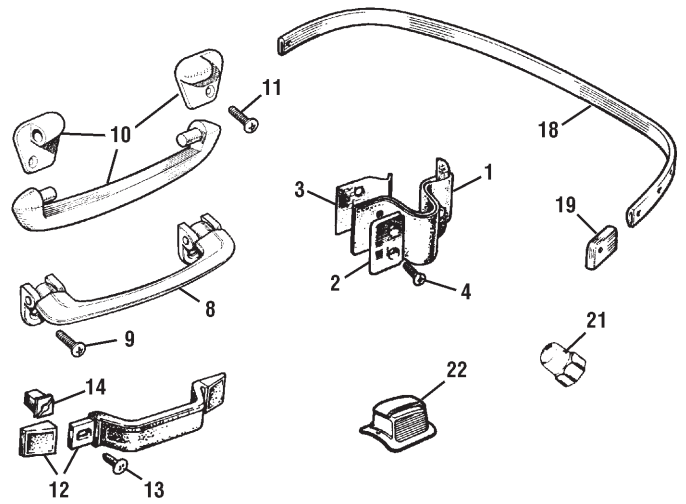

No.	Part No.	Price (each)	Description	Application	Qty. Req.
-----	----------	--------------	-------------	-------------	-----------

Cockpit Fittings

1	240-675	\$9.95	CHECK STRAP, black		2
	240-670	\$9.95	CHECK STRAP, red		2
	240-680	NA	CHECK STRAP, blue		2
	240-685	\$9.95	CHECK STRAP, navy		2
	240-690	\$9.95	CHECK STRAP, autumn leaf		2
2	240-815	\$1.65	RETAINER, check strap		2
3	240-805	\$3.55	BRACKET, check strap		2
4	314-315	\$0.55	SCREW		4
8	803-440	\$21.95	HANDLE, door pull	} Sprite to (c)72040	2
9	402-485	\$0.70	SCREW, door pull	} Midget to (c)60459	4
10	472-240	\$9.15	HANDLE, door pull	} Sprite from (c)72041 Midget (c)60460 to 105500	2
11	402-485	\$0.70	SCREW, door pull		4
12	402-453	\$14.95	DOOR PULL, black	} Midget from (c)105501 (1971-on)	2
	402-450	NA	DOOR PULL, autumn leaf		2
	402-455	\$14.95	DOOR PULL, yellow ochre		2
	402-490	NA	DOOR PULL, navy		2
13	314-285	\$0.25	SCREW, door pull		4
14	402-710	NA	CAPTIVE NUT		4
18	459-855	\$13.95	COCKPIT MOULDING, black vinyl	} 1967-80	1
19	240-560	\$9.15	END CAP, chrome R/H		1
	240-565	\$9.30	END CAP, chrome L/H		1
21	402-550	\$2.95	DOVE NUT, seat belt mounting	as fitted	4
22	241-015	\$38.45	ASHTRAY ASSEMBLY		1

Seats

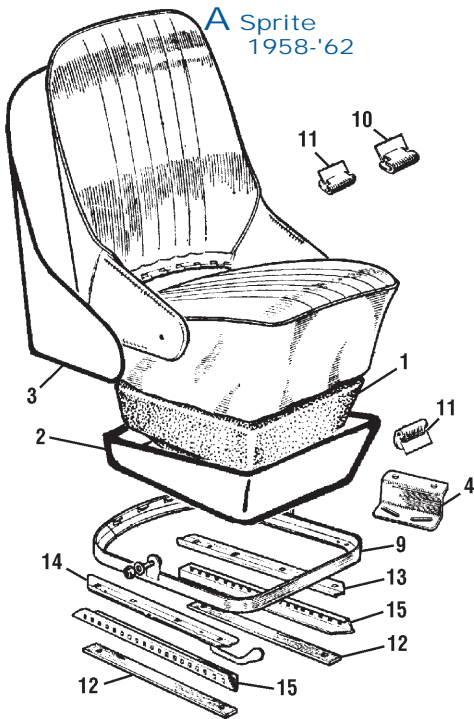

A Sprite
1958-'62

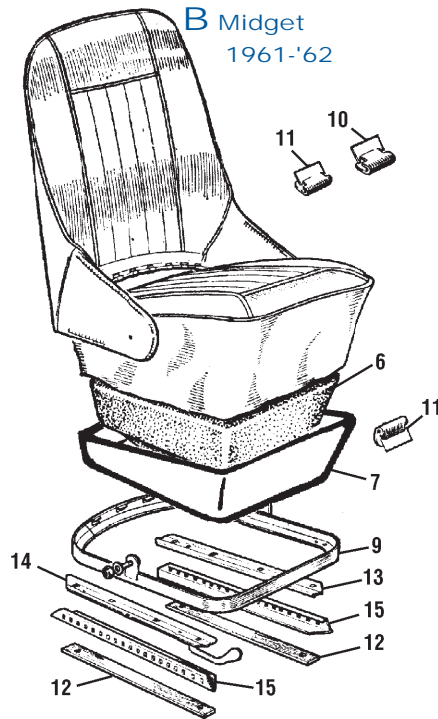

B Midget
1961-'62

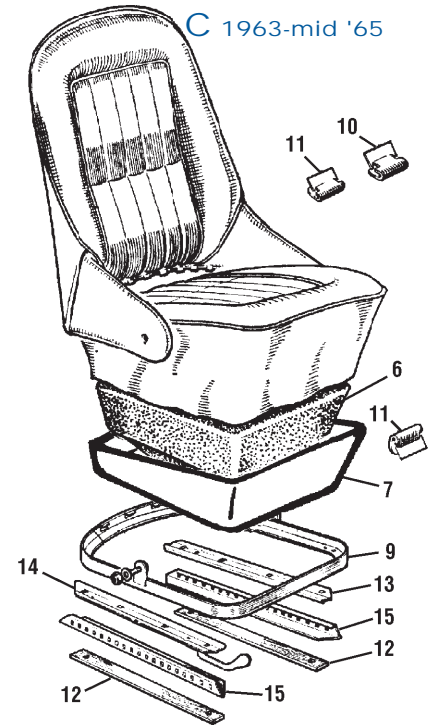

C 1963-mid '65

Vinyl Seat Kits

	Black with White Piping	Red with White Piping	Blue with Blue Piping	
A Bugeye Sprite, 948 Sprite Mk II to HAN7-24731	640-770	640-780	640-790	\$335.95
B 948 Midget Mk I to GAN1-16183	640-895	640-905	640-915	\$335.95
C 1098 Sprite Mk II & Mk III from HAN7-24732 to HAN8-55500 and Midget Mk I & Mk II from GAN2-16184 to GAN3-52389	640-855	640-865	640-875 (Navy/Navy) 640-876 (Lt.Blue/Wht)	\$347.95 \$348.95
D 1098 Sprite Mk III & 1275 Mk IV from HAN8-55501 to HAN9-77590 and 1275 Midget Mk III to GAN4-66225	640-910	640-920	640-840 (Blue/White)	\$347.95
E 1275 Sprite Mk IV from HAN9-77591 to HAN9-85286 (*Headrest covers not included) 1275 Midget Mk III from GAN4-66226 to GAN4-74885	Black			
	640-945* (fixed back)			\$347.95
	640-950* (reclining back)			\$350.95
F 1275 Sprite Mk IV* from HAN10-85287 on (*Headrest covers not included) 1275 Midget Mk III & Midget 1500* from GAN5-74886 thru 1500	Black	Autumn Leaf	Navy	
	640-960	640-980	640-930	\$338.95

Leather Seat Kits

	Black with White Piping	Red with White Piping	
A Bugeye Sprite, 948 Sprite Mk II to HAN7-24731	640-775	640-785	\$863.95
B 948 Midget Mk I to GAN1-16183	640-880	640-885	\$945.95
C 1098 Sprite Mk II & Mk III from HAN7-24732 to HAN8-55500 and Midget Mk I & Mk II from GAN2-16184 to GAN3-52389	640-825	640-835	\$914.95
D 1098 Sprite Mk III & 1275 Mk IV from HAN8-55501 to HAN9-77590 and 1275 Midget Mk III to GAN4-66225	640-845	640-925	\$960.95
E 1275 Sprite Mk IV from HAN9-77591 to HAN9-85286 1275 Midget Mk III from GAN4-66226 to GAN4-74885	Black		
	640-800 (fixed back)		\$945.95
	640-955 (reclining back)		\$400.00
F 1275 Sprite Mk IV from HAN10-85287 on 1275 Midget Mk III & Midget 1500* from GAN5-74886 thru 1500	Black	Autumn Leaf	
	640-805	640-810	\$917.95

Moss Seat Kits All front seat kits include covers for both front seats. No matter what else you do to your car, one thing which everyone notices is the condition of the seats. Put your seats in tip top condition with a "just as it came from the factory" vinyl kit, or upgrade your car's interior with one of our luxurious leather kits. (Don't forget pads and cushions - we stock a complete selection to properly fill out your new covers, and make your "new" seats as comfortable as can be.) All of the Sprite & Midget seat kits we sell are made in England of the very best materials, patterned exactly like the originals.



moss

MOSS MOTORS, LTD. TOLL-FREE ORDERS 1-800-667-7872

D mid 1965-'68

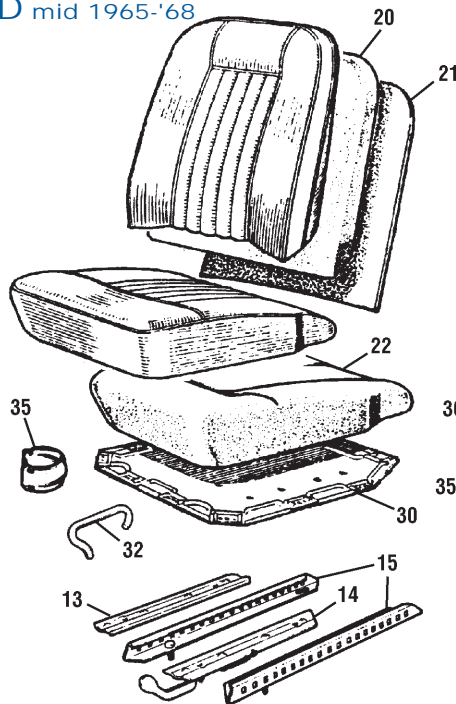

E 1969

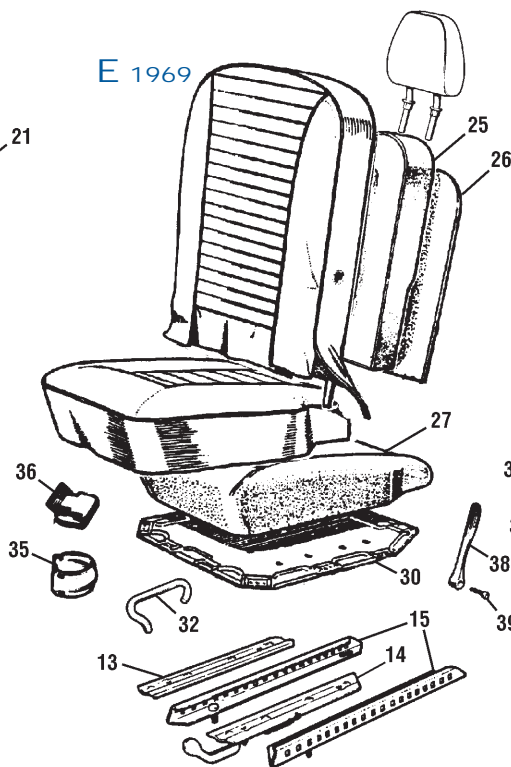

F Midget
1970-'80

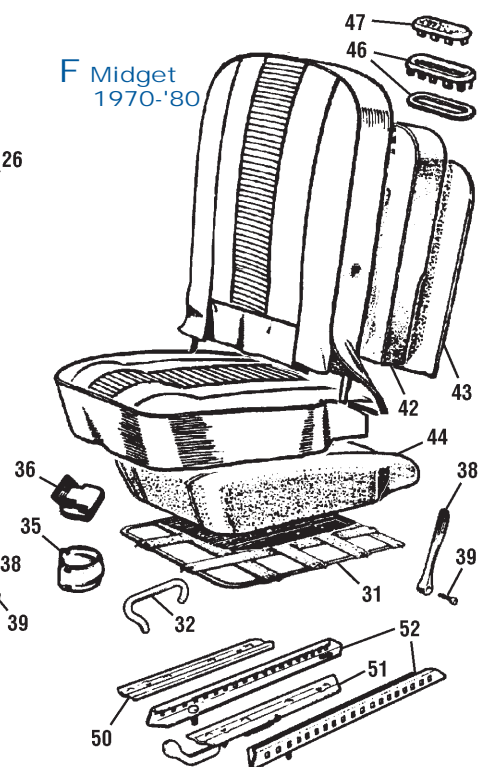

No.	Part No.	Price (each)	Description	Application	Qty. Req.
-----	----------	--------------	-------------	-------------	-----------

Seat Components

1	640-468	\$124.95	CUSHION & PADDING KIT (foam cushion, plus padding for seat back)	} seat "A"	2
2	640-570	\$199.95	BASE, steel		2
3	640-575	\$239.95	BACK, steel		2
4	640-630	NA	BRACKET, seat mounting *		4
*These brackets were used instead of seat slides on Bugeye passenger's seat. 948cc Sprite MkII (H-AN6) could be had with the passenger's seat mounted on either these brackets or on slides.					
6	640-478	\$199.95	FOAM CUSHION & PADDING KIT (foam cushion, plus padding for seat back)	} seats "B" & "C"	2
7	640-580	NA	BASE, steel		2
9	640-640	\$192.95	FRAME	} seats "A", "B", "C"	2
10	326-185	\$0.45	CLIP, seat back (large)		20
11	326-155	\$0.40	CLIP, back & cushion covers (small)		56
12	640-605	\$4.20	PACKING STRIP, wood		4
13	640-600	NA	RUNNER, upper, plain		2
14	640-585	NA	RUNNER w/lever, R/H	} seats "A" thru "E"	1
	640-595	NA	RUNNER w/lever, L/H		1
15	640-590	\$19.95	RAIL, lower		4
20	640-540	NA	BACK FOAM	} seat "D"	2
21	640-545	\$17.95	BACK BOARD		2
22	640-530	\$62.95	CUSHION FOAM		2
25	640-550	\$60.95	BACK FOAM	} seat "E"	2
26	640-505	NA	BACK BOARD, adjustable seatback		2
	640-635	NA	BACK BOARD, non-adj. seatback		2
27	640-560	\$60.95	CUSHION FOAM		2
30	281-828	\$25.95	DIAPHRAGM, rubber	seats "D", "E"	2
31	281-858	\$24.95	DIAPHRAGM, web	seat "F"	2
32	325-185	\$0.45	HOOK, diaphragm	} seats "D", "E", "F"	20
35	226-645	\$0.65	CLIP, cushion cover		A/R
36	326-185	\$0.45	CLIP, back cover	} seats "E", "F"	6
38	409-020	\$32.95	HANDLE, seat back adjusting		2
39	323-205	\$0.80	SCREW, handle		2

No.	Part No.	Price (each)	Description	Application	Qty. Req.
-----	----------	--------------	-------------	-------------	-----------

42	640-500	\$66.95	BACK FOAM, R/H	} seat "F"	1
	640-510	\$66.95	BACK FOAM, L/H		1
43	640-515	\$13.95	BACK BOARD		2
44	640-520	\$41.95	CUSHION FOAM	(installed on seat kits)	2
46	409-108	\$6.55	RING ASS'Y, headrest aperture		2
47	227-170	\$3.85	PLUG, black (when headrests out)		2
50	640-600	NA	RUNNER, upper, plain	} seat "F", 1970-'71 to approx. (c)105500	2
51	640-585	NA	RUNNER w/lever, R/H		1
	640-595	NA	RUNNER w/lever, L/H		1
52	640-610	\$13.95	RAIL, lower, r/h of ea. seat		2
	640-620	\$15.95	RAIL, lower, l/h of ea. seat		2
	NA	NA	RUNNER, upper, plain	} seat "F", 1972-'80 from approx. (c)105501	2
	NA	NA	RUNNER w/lever, R/H		1
	NA	NA	RUNNER w/lever, L/H		1
640-615	\$13.95	RAIL, lower, r/h of ea. seat	2		
640-625	\$13.95	RAIL, lower, l/h of ea. seat	2		



Midget Headrests

Beautiful reproductions of an often missing or weather-ruined upholstery part. (Sorry - twin-post headrests for 1969 cars are not available.)

	Black	Navy	Ochre	Autumn Leaf	Champagne	
1970-3/77 "Eared-type" perforated.						
649-100	NA	NA	649-130	N/A	\$62.95	
1977-'80 "Teardrop-type" non-perforated.						
641-605	641-615	N/A	641-635	641-535	\$63.95	

Diagnosing Wiring Troubles! (Words of Wisdom to Live and Drive By)

Does your car let you down every time you try to start it, or those wipers only work when it is not raining? Perhaps the indicators go dim every time you apply the brakes, and the horn only operates when the lights are off.

Before you go out to buy new lights, horns, switch gear, voltage rectifiers and anything else that carries an electrical current, it may be worthwhile spending time checking out the wiring rather than shelling out on new parts.

Quite often I have found that electrical components sup-

posedly faulty, are perfectly all right, i.e., "blown" headlamps which are intact, switches that work when connected to a multi-tester, horns that stop making funny gurgling noises and operate correctly when connected to the battery for a test.

Many electrical faults are caused by two frequently overlooked factors, either working separately, or together to produce a variety of interesting visual and sometimes pyrotechnic effects. The first of these factors is simply caused by age and the climate - electro-rheumatism if you like. The second is caused by that stalwart of the motoring world, Captain

Accessory!

I am always surprised by the large number of good quality products on the market (and this does include radios, etc.) which are let down either by the cheap, easy-to-use connectors sold with the kit, or by "hash wiring" on the part of the installer. Fitting any accessory should be dealt with in the same way that any other task should be undertaken on a vehicle - properly. Connections should be mechanically and electrically sound.

The worst electrical problems I have faced have been caused by "bodged" wiring or faulty connections. Easy-to-use connectors often provide me with hours of entertainment, as does unwrapping electrical insulation tape to find wires that have been just cut, stripped back and twisted together. It always works for a while!

And it's not bodged wiring - some products are of an appalling quality. For example, I have tried various different HT leads in my car to "improve the quality of the spark", "reduce resistance", and "provide better ignition". Most of these leads have been useless. It doesn't matter two hoots that the PTFE casing and superior quality copper core offers less resistance than the normal standard item - what matters is that if the cap doesn't fit the spark plug, it will just bounce off. One famous make had such appalling connections that it would not fit into the standard Lucas distributor. If you are going to tackle any electrical work for your car, then do it properly and do it once. Throw away those cheap connectors and get the right tools to do the job properly - because I can guarantee that if you don't, that one day you'll wish you had - or even worse, you'll get rid of the car because it keeps going wrong. (I've picked up a few cheap cars like that which sing after two or three hours with a soldering iron!)

Get the Right Tools:

1. Soldering Iron - Get one with: 5 to 15 watts output, stay clean tips, decent stand, and PTFE leads (which make the iron easy to handle).
2. You probably already own one of those multi-purpose devices that cuts, strips wires and fits connectors. Throw it in the trash. Buy instead: Long Nose Pliers, Side Cutters, Wire Strippers, Insulation Tape, and Solder (60 - 40 lead/tin mix with flux incorporated).
3. Connectors - Get the type of connectors that are already in use on your car - spade connectors and bullet connectors (that can be soldered) and throw the crimp connectors into a bin!

Three important safety tips:

1. Disconnect the Battery

A fully charged battery can use around 120 amps to turn over a cold car engine. Making a mistake and accidentally connecting the positive to the earth can have some interesting affects, i.e.:

- i. Any wire involved in a direct connection will act like a fuse and melt (this includes HT wire).
- ii. The battery could explode if an HT wire does not fuse quickly enough.
- iii. 120 amps is enough to weld your screwdriver to any object very easily.
- iv. You can receive nasty burns if you use yourself as a suitable earthing point. (Remember DC current differs from AC in that it does not change direction - once you get to grips with DC it won't let go!)

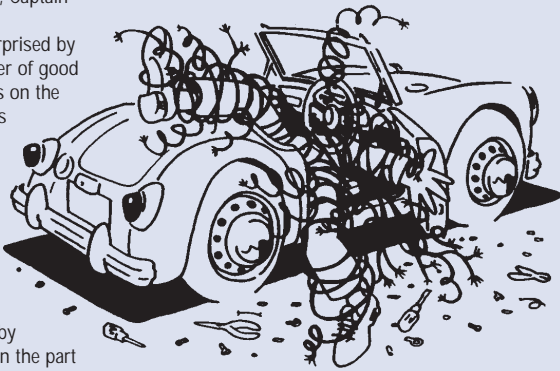

2. Holding the soldering iron

Never grab the soldering iron if it starts to fall. Sounds obvious, but there are still plenty of electrical engineers around who hold out their left hand when greeting somebody!

3. Suitable wiring

Finally, make sure that the wires you are using have the correct current capacity for the power they have to take. Using cable that is too thin is the electrical equivalent of reducing three lanes of motor way into one - total breakdown - if the current is much higher than the wire, the wire will act like a fuse and melt.

Making Connections

1. Spade connectors

Strip back 1/4" of wire without ripping out half of the strands, (if you have never used wire strippers before, have plenty of practice with some old bits of wire) twist the strands together and solder the bare end.

Always heat the wire with the soldering iron and apply the solder to the wire while it is still in contact with the iron. The wire must be hot enough for the solder to flow into the wire strands - but don't keep the iron there for too long, otherwise the outer sleeve of the wire will melt back. It is an art worth learning.

Do not apply solder to the iron and then try to "blob" the solder on to the wire - it never works because the solder "dries out" as the flux evaporates, and then the resulting joint can become brittle and prone to breaking (aka "Dry Joint").

Once cool, fit a spade connector sheath over the wire and then crimp the connector to the wire as shown in the diagram. The crimping makes a mechanically sound connection, but this is not enough. Returning to the soldering iron, you then need to apply heat to solder the wire to the connector to ensure an enduring connection, just like they do at the factory.

2. Bullet connectors

Bullet connectors are needed where (A) two separate lengths of wire are to be joined together or (B) where an extra wire is to be added to a main feed.

Many bullet connectors can be crimped on as well as soldered to enhance the quality of their connection, but the stock items used by BL tend to be a bit more tricky and can only be soldered - so you must ensure that the soldered connection is not dry! Strip back 3/8" of cable and solder the strands. Insert in the end of the bullet - it may help to "kink" the strands slightly to keep the bullet in place - and then re-apply the soldering iron to the top of the bullet. Allow it to heat up and then apply the solder through the hole at the top of the bullet so that it can run inside, attaching the cable to the wall of the connector.

The advantage of these connectors is that, if corroded, the connector block can be thrown away and a new one fitted without having to do any more soldering. Also, they can provide multiple outlets for power, but watch out for that current overload on the original feed wire!

The disadvantage is that the connector is a mechanical fit and prone to electrical failure when corroded, which is why many cars start going wrong after five year's use!

An Extra Fuse Box

If you are accessory mad, the use of a fuse box with a direct link to the solenoid may provide a safe, efficient answer, rather than connecting countless new wires onto an overburdened wire feed.

Again, make sure that the wire, from the feed to the box has sufficient capacity to deal with any load placed upon it (an in-line fuse may further protect the entire system).

Is it worth the effort you might ask? Yes! A clean job is a good job!

1. If it's soldered, then the connections will be better, stopping niggling electrical failures and dangerous burn-outs; the connectors are cheaper too.
2. The proper connectors often allow easier access for repair of equipment.
3. Stops wires from sparking and equipment lasts longer.
4. It looks better, too!

Grahame Bristow
Moss Europe Staff

Sprite-Midget

Tops & Tonneau Covers

Vinyl Tops

Includes all necessary snaps and fasteners. Header rail and rear anchor bar are not included.

	Color	Part No.	Regular
Bugeye W/Shield Studs	Black	242-180	\$284.95
Bugeye W/Shield Rod		242-185	284.95
1962-ON W/Side Curtains	Black	242-190	288.95
1964-66 (Winding Window)		242-195	279.95
1967-69 (8 Studs)	Black	242-175	283.95
1969-ON (6 Studs)		242-200	281.95
OE Type Replacement Top W/Header Rail			
1969-ON (6 Studs)	Black	242-205	589.95

Sun-Fast Tops

	Color	Part No.	Regular
Bugeye w/ windshield studs	Black	242-181*	\$632.95
	Tan	242-182*	632.95
Bugeye w/ windshield rod	Black	242-186*	632.95
	Tan	242-187*	632.95
1962-on w/ side curtains	Black	242-191*	621.95
	Tan	242-192*	621.95
1964-66 (winding window)	Black	242-196*	588.95
	Tan	242-197*	588.95
1967-69 (8 studs)	Black	242-176*	588.95
	Tan	242-177*	588.95
1969-on (6 studs)	Black	242-201*	588.95
	Tan	242-202*	588.95

Vinyl Tonneau Covers

Includes all necessary snaps and fasteners. Header rail and rear anchor bar are not included.

	Color	Part No.	Regular
Bugeye	Black	241-270	\$253.95
1962-on W/Side Curtains	Black	241-280	269.95
1964-66 (Winding Window)		241-285	305.95
1967-on (No H/Rests)	Black	241-290	288.95
1967-on (With H/Rests)		241-300	301.95

Sun-Fast Tonneau Covers

	Color	Part No.	Regular
Bugeye	Black	241-271*	\$546.95
	Tan	241-272*	546.95
1962-on w/ side curtains	Black	241-281*	573.95
	Tan	241-282*	573.95
1967-on w/ headrests	Black	241-291*	590.95
	Tan	241-292*	590.95
1967-on w/ out headrests	Black	241-301*	617.95
	Tan	241-302*	617.95

* All items denoted by an asterisk are made to order. Please allow 6 to 10 weeks for delivery.



Side Curtains

	Part No.	Regular
Side Curtain Set	259-678	\$459.95



ORDER ONLINE or CALL: 1-800-667-7872
mossmotors.com

MOSS

NEW Sprite-Midget Supercharger System



The new Moss Motors designed supercharger system uses the same Eaton positive displacement Roots type supercharger found on contemporary applications such as Jaguar and Mercedes Benz.

Designed to fit the 1275cc engine, the kit will work with either generator or alternator equipped applications. The extra loading will reduce the life of generator bearings, so we also offer an alternator upgrade kit.

Our engineers designed an intake manifold that provides equal airflow, pressure and fuel mixture to each cylinder. This careful design works with the supercharger to increase torque even at idle. The latest generation Eaton blower features an internal bypass system that improves operating efficiency and reduces fuel consumption by allowing the boosted mixture to re-circulate under low load conditions, cutting down on drag.

The supercharger kit is very complete and includes a 4 rib serpentine belt drive system with automatic adjustment. Carburetion is provided by the latest version of the SU HIF44 and a K&N air filter is included to make the package complete. A new water pump, NGK spark plugs and very detailed instructions make installation a breeze.

A dramatically linear increase in torque and power produce a driving sensation without the drivability, cooling and fuel consumption problems normally found with traditional performance modifications.

A competent mechanic or hobbyist can install the kit in about 8 hours, but professional installers may charge as much as 12 hours to ensure that all other systems are in good shape and that the tuning is spot on.

150-088 1275cc Sprite/Midget Supercharger System \$3145.00



- 100,000 mile limited warranty on the Supercharger rotor assembly.
- Jetted and modified SU HIF 44 carburetor
- K & N air filter
- New Water Pump
- Automatic belt tensioning
- All hardware for installation
- Detailed instructions

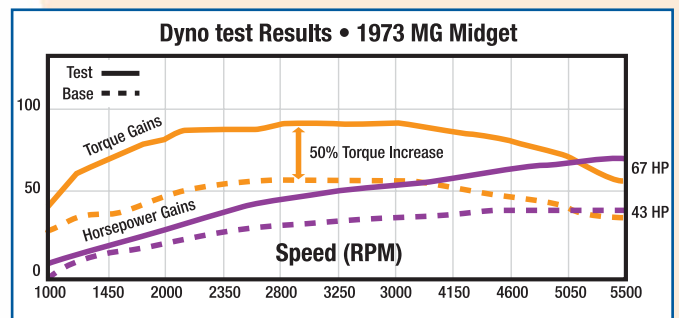

Was 43 HP **Now 67 HP!**
Was 53 Ft. Lbs. **Now 78 Ft. Lbs.!**

These results were both recorded on a Mustang Dynamometer and show the relative improvement to a 1973 MG Midget with stock 1275cc engine. Dynamometers will vary, so when comparing horsepower figures always reference the type of unit used. For comparison, the modified engine pictured produced 95.4 HP @ 6000 rpm and 89.0 Ft-Lbs of Torque @ 4250rpm. This was achieved with an alloy head, 1330cc overbore and high boost upgrade kit.

Extremely detailed instructions and a list of Frequently Asked Questions may be previewed at www.mossmotors.com

TOLL FREE
800.667.7872
FAX 805.692.2525

OVERSEAS ORDERS
805.681.3400

VISIT US ONLINE
www.mossmotors.com



Moss Motors, Ltd.
 440 Rutherford Street
 P.O. Box 847
 Goleta, CA 93117

CHANGE SERVICE REQUESTED